



**STORMGUARD FIBERGLASS DOOR UNIT**  
**6'-8" DOUBLE DOOR WITH / WITHOUT SIDELITES**

GENERAL NOTES

1. EVALUATED FOR USE IN LOCATIONS ADHERING TO THE FLORIDA BUILDING CODE AND WHERE PRESSURE REQUIREMENTS AS DETERMINED BY ASCE 7, MINIMUM DESIGN LOADS FOR BUILDINGS AND OTHER STRUCTURES, DOES NOT EXCEED THE DESIGN PRESSURES LISTED.
2. THIS PRODUCT DOES NOT REQUIRE THE USE OF A HURRICANE PROTECTIVE SYSTEM (SHUTTERS).
3. POLYURETHANE CORE FLAME SPREAD INDEX OF 50 AND SMOKE DEVELOPED INDEX OF 60 PER ASTM E84.

4. PLASTICS TESTING:

TEST DESCRIPTION	DESIGNATION	FACING	LITE FRAME
SELF IGNITION TEMP	ASTM D1929	752 °F > 650 °F	842 °F > 650 °F
RATE OF BURNING	ASTM D635	0.56 IN/MIN	1.28 IN/MIN
SMOKE DENSITY	ASTM D2843	53.4%	70.2%
TENSILE STRENGTH*	ASTM D638	3.2% DIFF	1.8% DIFF

5. PLASTICS TESTING OF WORLDWIDE COMPOSITE FRAME (WHERE USED):

TEST DESCRIPTION	DESIGNATION	RESULT
SELF IGNITION TEMP	ASTM D1929	779 °F > 650 °F
RATE OF BURNING	ASTM D635	0.0 IN/MIN
SMOKE DENSITY	ASTM D2843	39.0%
TENSILE STRENGTH*	ASTM D638	3.6% DIFF

\* COMPARATIVE TENSILE STRENGTH AFTER WEATHERING  
 4500 HOURS XENON ARC METHOD 1

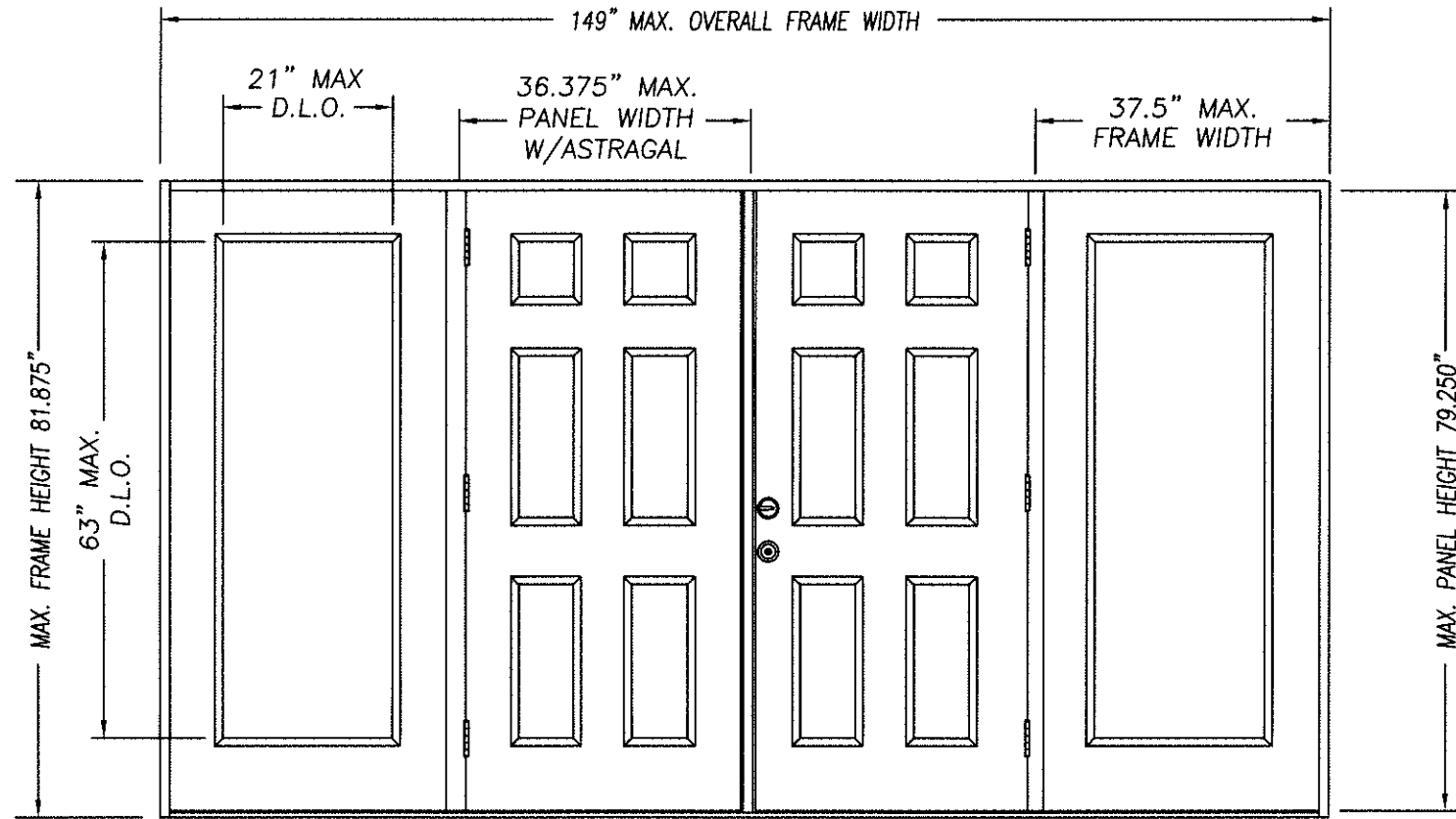

DOUBLE DOOR UNIT W/SIDELITES

Addendum to NAMI

Certification No.: NI007077  
 Reviewed By: [Signature]  
 Date Reviewed: 5/4/17

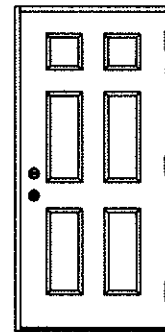

SINGLE DOOR UNIT

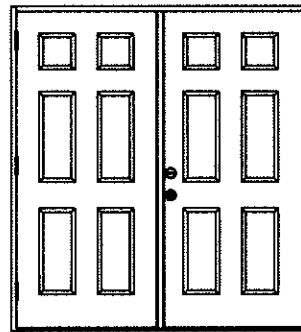

DOUBLE DOOR UNIT

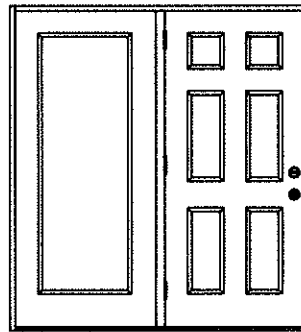

SINGLE DOOR UNIT WITH SIDELITE

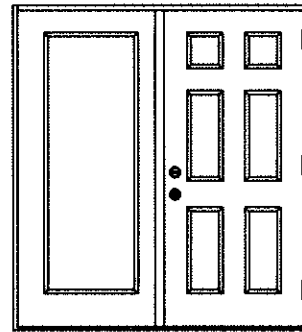

SINGLE DOOR UNIT WITH SIDELITE

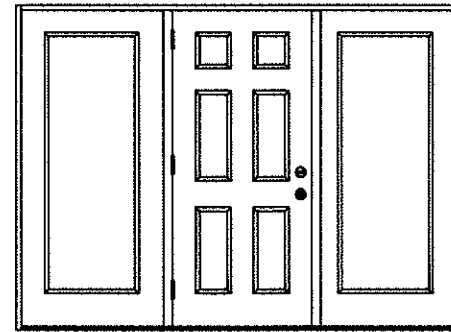

SINGLE DOOR UNIT W/SIDELITES

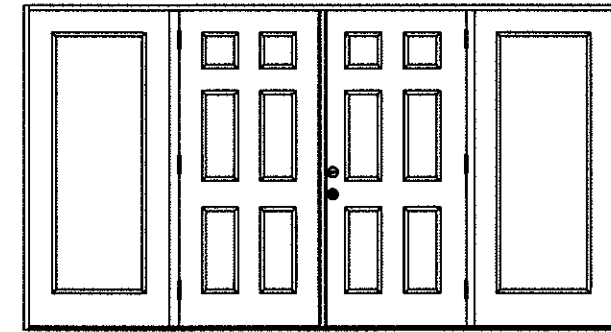

DOUBLE DOOR UNIT W/SIDELITES

TABLE OF CONTENTS

SHEET #	DESCRIPTION
1	TYPICAL ELEVATIONS & GENERAL NOTES
2	ANCHORING LOCATIONS & DETAILS
3	ANCHORING LOCATIONS & DETAILS

CONFIG	MAX WIDTH	DESIGN PRESSURE RATING		WHERE WATER INFILTRATION PERFORMANCE IS REQUIRED TO BE 15% OF DESIGN PRESSURE				
		INSWING	OUTSWING	INSWING	BUMPER O/S	Z-SERIES O/S	HIGH DAM O/S	
X	37.5"	+60.0 / -65.0	+60.0 / -60.0	N/A	+25.0 / -25.0	+40.0 / -40.0	+60.0 / -60.0	
XX	74"	+50.0 / -50.5	+55.0 / -50.5	N/A	+25.0 / -25.0	+40.0 / -40.0	+55.0 / -50.5	
OX or XO	75"	+50.5 / -50.5	+55.0 / -50.5	N/A	+25.0 / -25.0	+40.0 / -40.0	+55.0 / -50.5	
OXO	112.5"	+50.5 / -50.5	+55.0 / -50.5	N/A	+25.0 / -25.0	+40.0 / -40.0	+55.0 / -50.5	
OXXO	149"	+50.0 / -50.5	+55.0 / -50.5	N/A	+25.0 / -25.0	+40.0 / -40.0	+55.0 / -50.5	

*Kurt Balthazor*

KURT BALTHAZOR  
 FLORIDA P.E.  
 #56533

MASONITE INTERNATIONAL CORP.  
 1955 POWIS ROAD  
 WEST CHICAGO, IL 60185

PRODUCT: "EXTERIOR DOOR PRODUCT"  
 DOUBLE 6'8" OPAQUE FIBERGLASS DOOR  
 PART OR ASSEMBLY:  
 TYPICAL ELEVATIONS & GENERAL NOTES

NO.	DATE	BY	REVISIONS
C	4/26/17	SWS	VARIOUS UPDATES
B	5/28/15	SWS	ANCHOR UPDATE
A	11/2/10	SWS	MISC UPDATES

DATE: 4/9/07  
 SCALE: N.T.S.  
 DWG. BY: SWS  
 CHK. BY:  
 DRAWING NO.:  
 DWG-MA-FL0170-07  
 SHEET 1 OF 3

MASONITE INTERNATIONAL CORP.  
 1955 POWIS ROAD  
 WEST CHICAGO, IL 60185

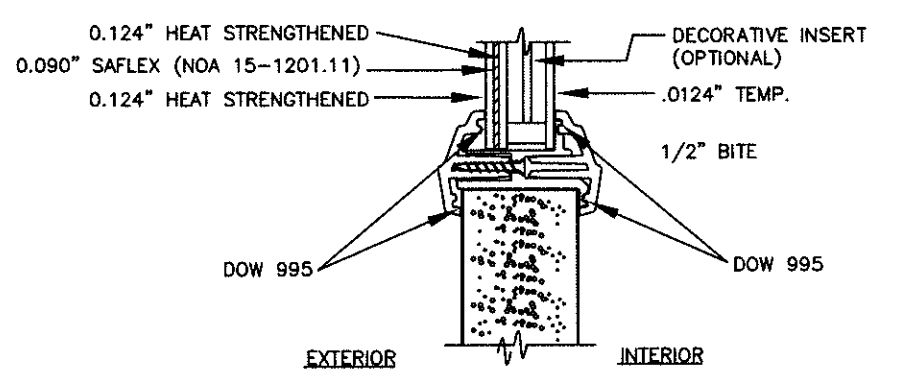
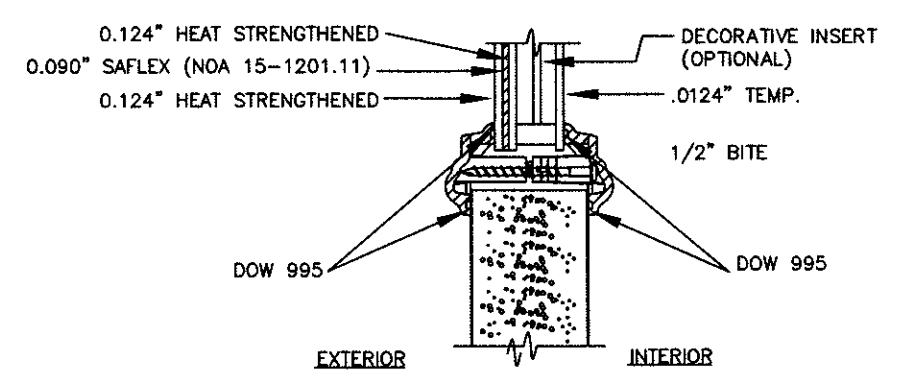
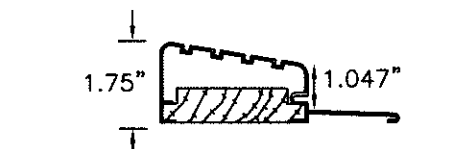
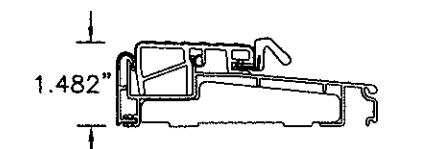
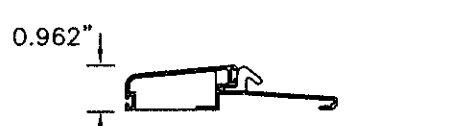
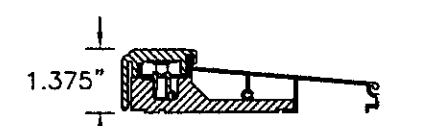
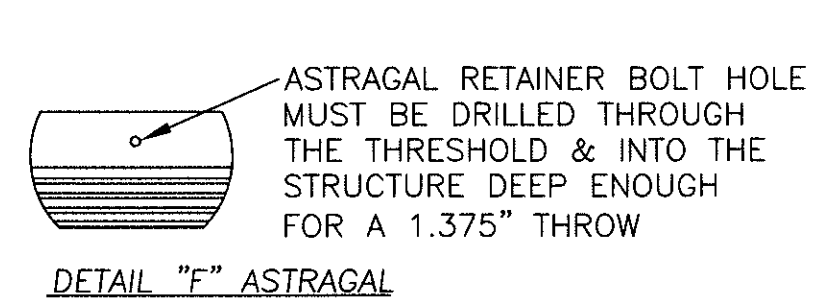
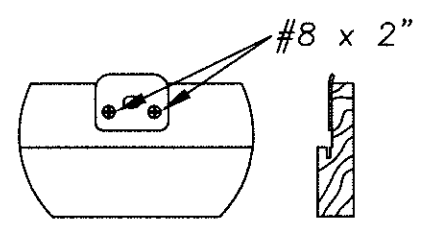
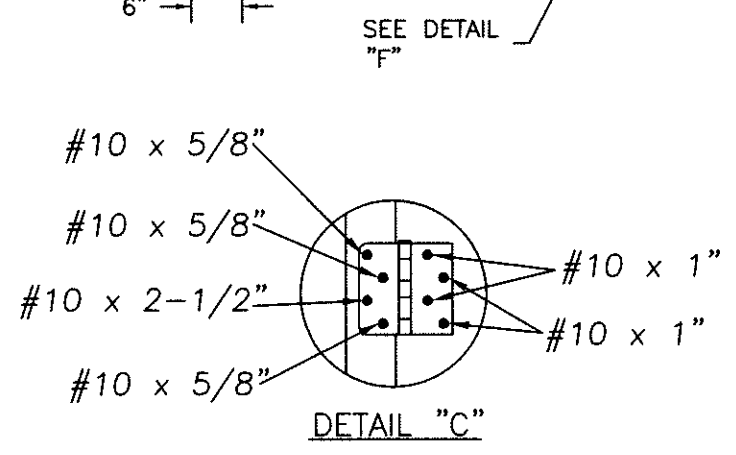
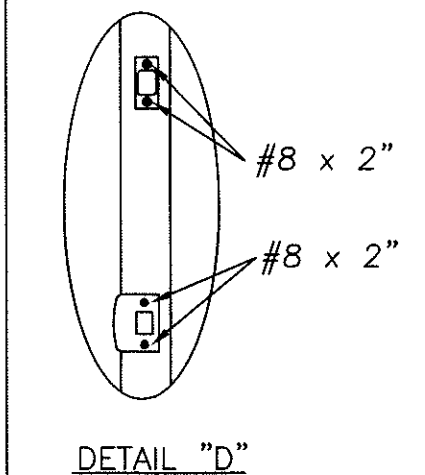
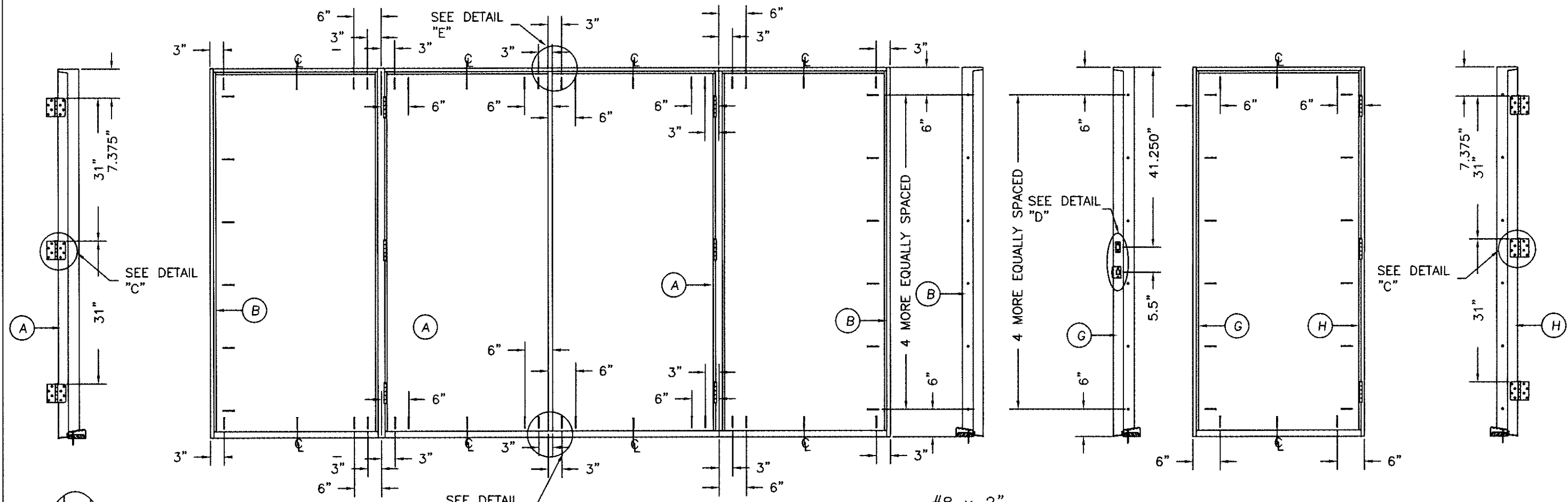

PRODUCT: EXTERIOR DOOR PRODUCT  
 6'-8" FIBERGLASS OPAQUE DOUBLE DOOR UNIT  
 PART OR ASSEMBLY: ANCHORING LOCATIONS & DETAILS

NO.	DATE	REVISIONS
C	4/26/17	VARIOUS UPDATES
B	5/28/15	ANCHOR UPDATE
A	11/2/10	MISC UPDATES
		BY
		SWS
		SWS
		SWS

DATE: 4/9/07  
 SCALE: N.T.S.  
 DWG. BY: SWS  
 CHK. BY:  
 DRAWING NO.: DWG-MA-FL0170-07  
 SHEET 2 OF 3

PRODUCT: EXTERIOR DOOR PRODUCT  
 6'-8" FIBERGLASS OPAQUE  
 DOUBLE DOOR UNIT  
 PART OR ASSEMBLY:  
 ANCHORING LOCATIONS  
 & DETAILS

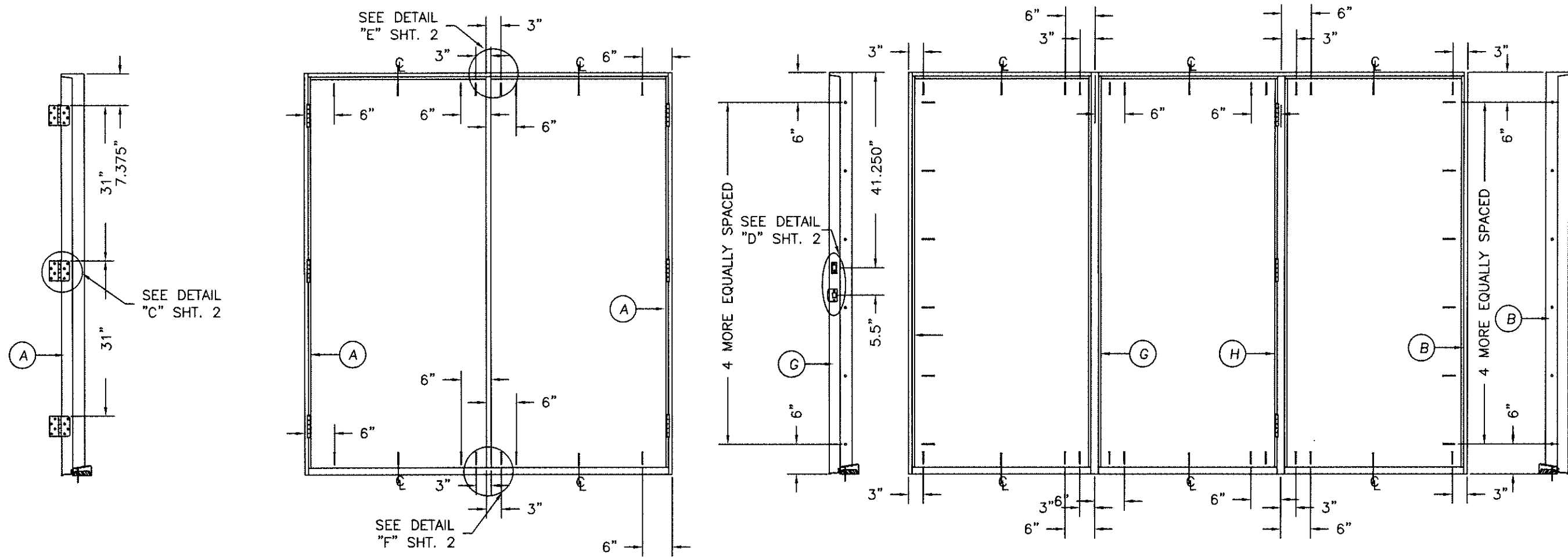

**HARDWARE SCHEDULE**

1.	KWIKSET SERIES 400 GRADE 3 CYLINDRICAL LATCH AND SERIES 980 GRADE 1 DEADLOCK HARDWARE TO BE INSTALLED AT 5-1/2" CENTERLINE.
2.	4" X 4" FULL MORTISE BUTT HINGES.

**ATTACHMENT DETAIL**

1. ANCHOR ANALYSIS FOR LOADING CONDITIONS PREPARED, SIGNED AND SEALED BY ROBERTO LOMAS, PE (FLORIDA #62514) WITH THE LOWEST (LEAST) FASTENER RATING FROM THE DIFFERENT FASTENERS BEING CONSIDERED FOR USE. JAMB, HEAD, AND THRESHOLD FASTENERS ANALYZED FOR THIS UNIT INCLUDE #10 WOOD SCREWS OR 1/4" TAPCONS. A PHYSICAL SHIM MUST BE PLACED IN SHIM SPACE AT EACH ANCHOR LOCATION. TAPCON EDGE DISTANCE MIN 2-1/2". WOOD SCREW EDGE DISTANCE MIN 3/4".
2. THE WOOD SCREW SINGLE SHEAR DESIGN VALUES COME FROM ANSI/AF&PA NDA FOR SOUTHERN PINE LUMBER AND ACHIEVEMENT OF 1-1/2" MINIMUM EMBEDMENT. THE TAPCON MUST ACHIEVE MINIMUM EMBEDMENT OF 1-1/4".
3. WOOD BUCKS BY OTHERS MUST BE ANCHORED PROPERLY TO TRANSFER LOADS TO STRUCTURE.
4. MINIMUM DESIGN VALUE STRENGTH OF ANCHORS 155 LBS.

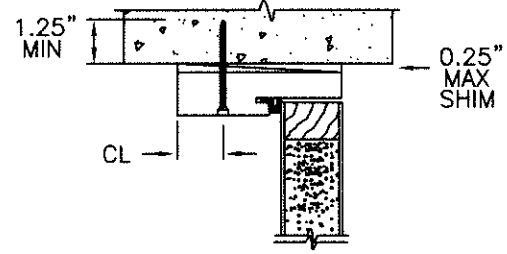

TYPICAL MASONRY ANCHOR INSTALLATION

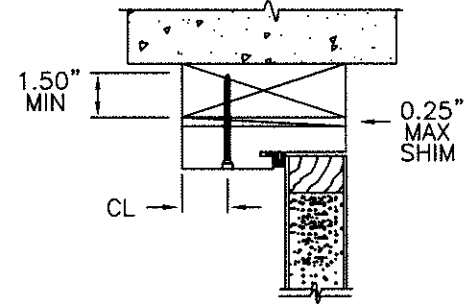

TYPICAL WOOD BUCK ANCHOR INSTALLATION

1"X1/2" CORRUGATED  
 3" FROM EACH END  
 AND 7" OC

#10X2" WOOD SCREW  
 6" FROM EACH END  
 AND 12" OC

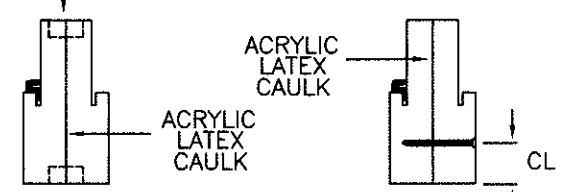

COMBINATION WOOD MULLION (BOXED)      COMBINATION WOOD MULLION (BOXED)

(3) #10X2-1/2"  
 WOOD SCREWS  
 EACH END

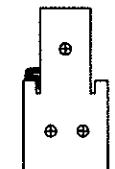

INTEGRAL WOOD MULLION (CHS)

(4) #10X2-1/2"  
 WOOD SCREWS  
 EACH END

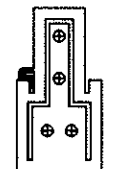

INTEGRAL WW MULLION (CHS)

NO.	DATE	REVISIONS
C	4/26/17	VARIOUS UPDATES
B	5/28/15	ANCHOR UPDATE
A	11/2/10	MISC UPDATES
		BY

DATE: 4/9/07  
 SCALE: N.T.S.  
 DWG. BY: SWS  
 CHK. BY:  
 DRAWING NO.:  
 DWG-MA-FL0170-07  
 SHEET 3 OF 3