

MODEL DESIGNATION: Simonton Casement Series 08-09 / 08-10 / 08-20 Vinyl Impact Window
MAXIMUM OVERALL NOMINAL SIZE: See Size Chart
DESIGN PRESSURE RATING: See Size Chart
USABLE CONFIGURATIONS: X
GENERAL DESCRIPTION: The head, sill, and side jambs are extruded PVC. The wall thickness through which the anchor screw penetrates is a minimum of 0.070".

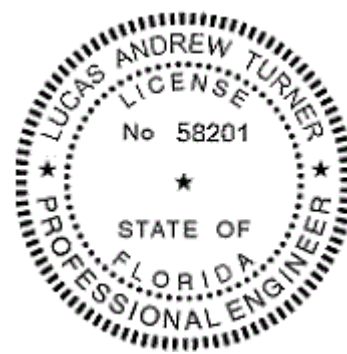

22
 5/19/2017
 LUCAS A. TURNER, P.E.
 FL PE # 58201
 TURNER ENGINEERING & CONSULTING, INC.
 (COA # 29779)
 1239 JABARA AVE.
 NORTH PORT, FL 34288
 PH. 941-380-1574

REV. #	REVISIONS:	REVISED BY:	DATE:
4	CORRECTED LOCATION OF #10 INSTALLATION SCREWS.	T.D.D.	06/02/11
5	ADDED OPTIONAL GLAZING DETAIL.	T.D.D.	11/15/13
6	UPDATED FOR MULTIPLE SUBSTRATE TYPES	L.A.T.	09/06/14
7	ADDED ANNEALED OUTBOARD	L.A.T.	06/30/15
8	ADDED TEST REPORT NUMBERS	LMH	05/16/17

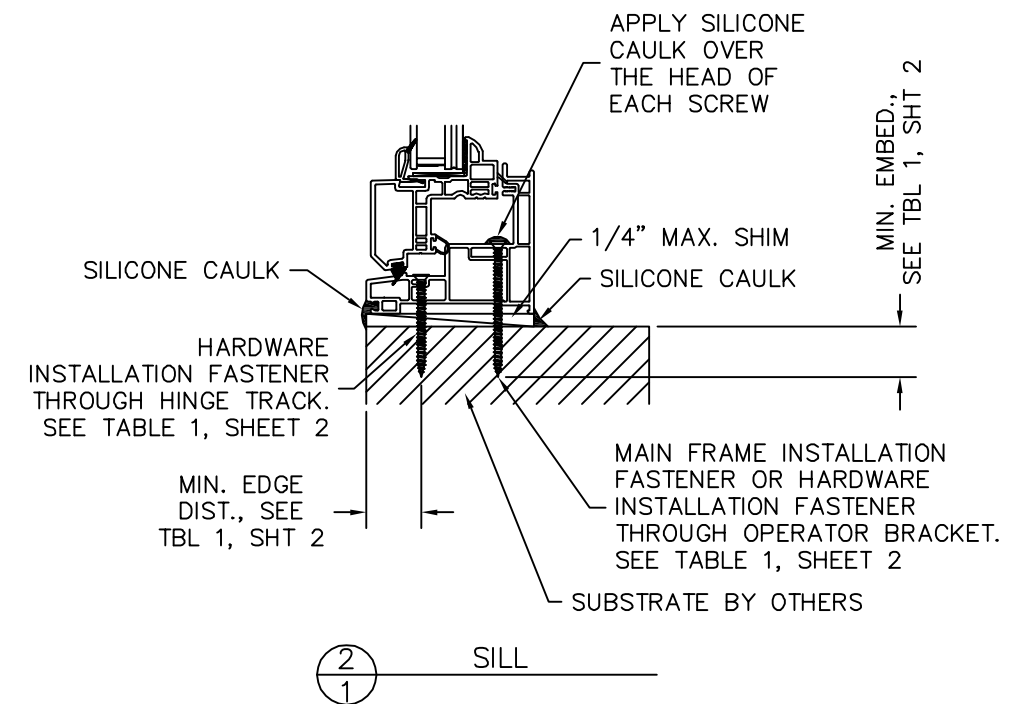
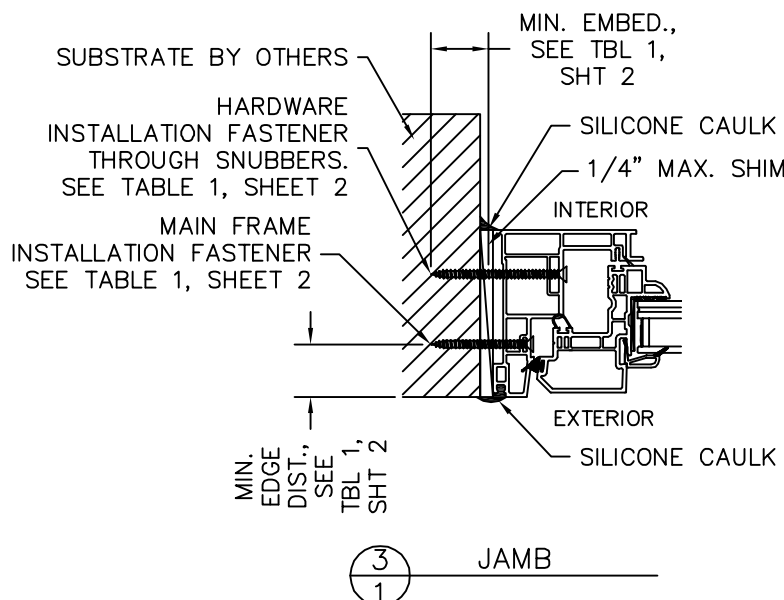
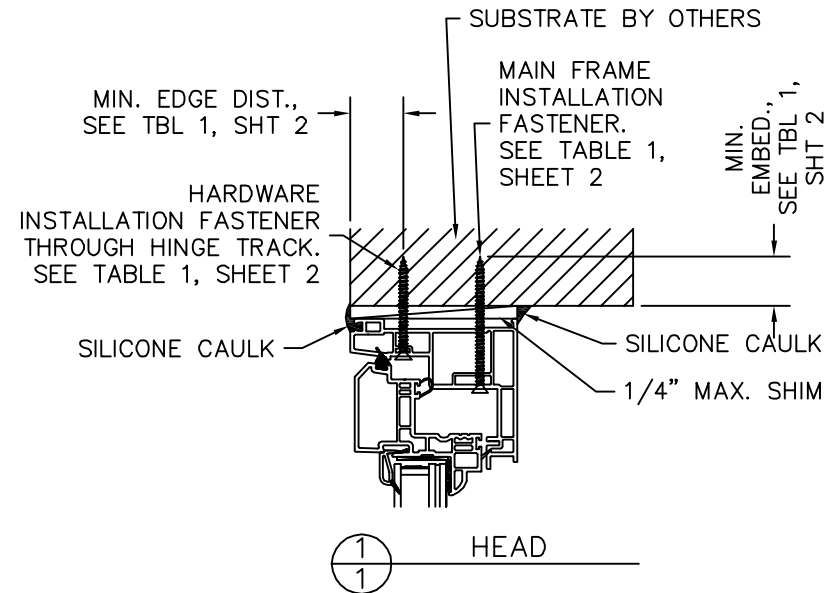
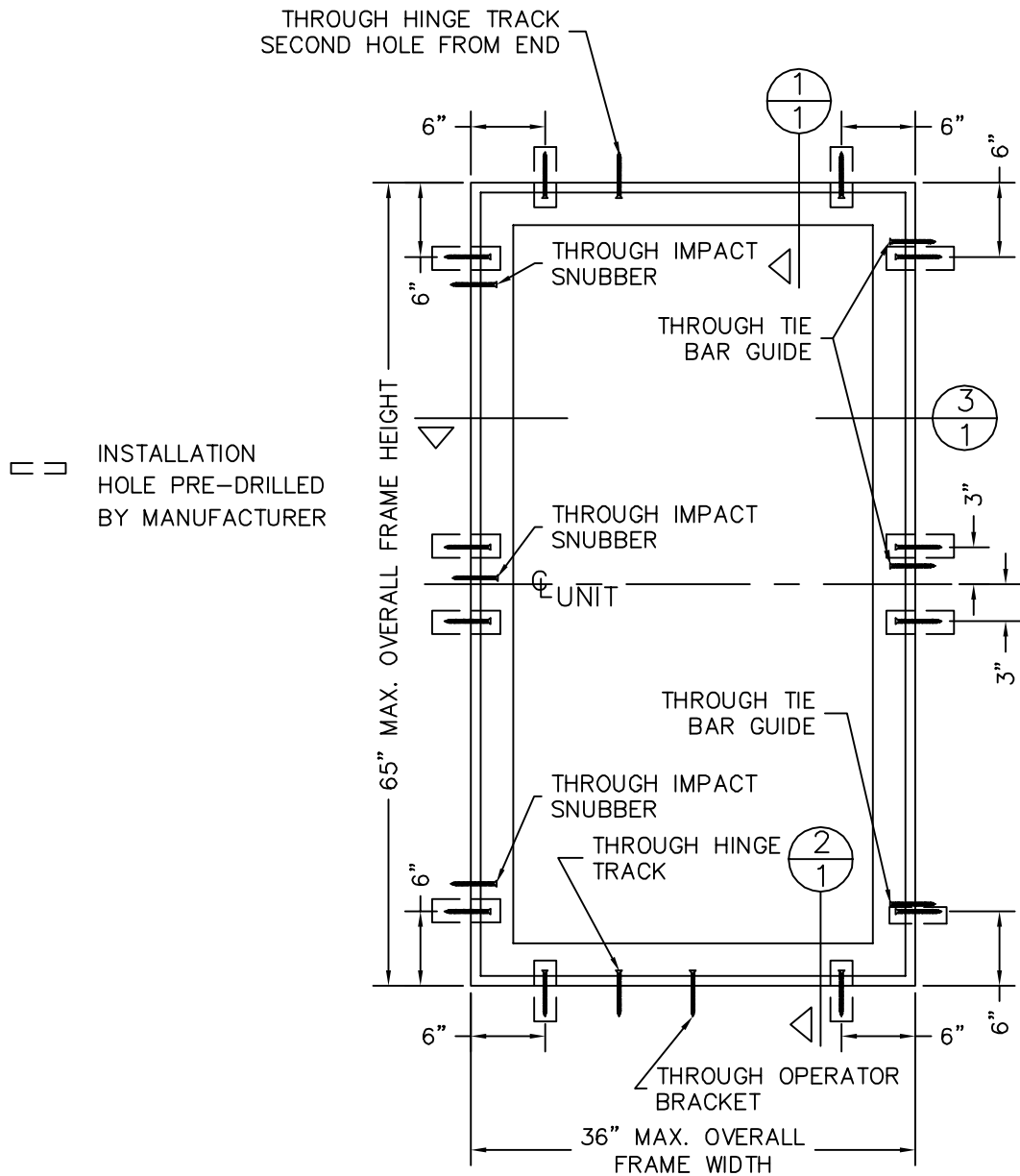

SIZE CHART		
OVERALL SIZE		DP RATING
WIDTH	HEIGHT	
36"	50"	±55 PSF
30"	65"	±55 PSF

DISCLOSURE STATEMENT
 This document is the property of Simonton Windows, which retains all proprietary and other rights to its subject matter. This document is provided to the recipient on the expressed condition that it is not to be disclosed, reproduced in whole or part, nor used in conjunction with the design, manufacture or repair of goods for anyone other than Simonton Windows without its consent. This restriction does not limit the recipient's rights to utilize information contained in this document which is properly obtained from another source.

FILE: IN0369

MATERIAL:
 RMS FINISH:
 ALLOY & TEMPER:
 WEIGHT:
 SURFACE AREA:
 FINISH TREATMENT:

Dimensional Tolerances Unless Otherwise Specified
 Decimals Angles
 .X ± .03
 .XX ± .01
 .XXX ± .005
 0° 30 min.

SIMONTON
 WINDOWS
 1 Cochrane Avenue
 Pennsboro, WV 26415

SIZE: B	DRAWING NO.: IN0369	REV.: 8
DRAWN BY: T.D.D.	DATE: 11/14/08	
CHECKED BY:	DATE:	
SCALE: FIT	SHEET: 1 of 2	APPR'VD BY: DATE:
SERIES: 08-09 / 08-10 / 08-20 CASEMENT IMPACT WINDOW		
TITLE: ELEVATION, INSTALLATION DETAILS		

NOTES:

1. This installation has been evaluated for use in locations adhering to the Texas & Florida Building Codes and where pressure requirements as determined by ASCE 7 Minimum Design Loads for Buildings and Other Structures do not exceed the design pressure ratings herein, for use outside the H.V.H.Z.
2. All interior and exterior perimeter surfaces of the window must be caulked.
3. Anchor type, size, spacing, and embedment shall be as specified in these drawings.
4. Anchor embedment to substrate shall be beyond wall dressing or stucco. For concrete/CMU openings embedment shall be beyond wood bucks, if used, and into substrate. Installations to solid concrete or grout-filled CMU may include but do not require 1x wood bucks between product and substrate. Installations to hollow CMU require the use of 1x bucks between product and substrate.
5. Wood or masonry openings, bucks, and buck fasteners, by others, shall be properly designed and installed to transfer wind loads to the structure. Substrates shall meet the minimum strength requirements as shown in Table 1, this sheet. Concrete or masonry substrates shall not be cracked.
6. The responsibility for selection of Simonton products to meet any applicable local laws, building codes, ordinances, or other safety requirements rests solely with the architect, building owner, or contractor.
7. Shims are required where gaps of greater than 1/16" exist between opening and frame. Max. shim stack is 1/4". Shims shall be load-bearing and capable of transferring loads to the substrate.
8. When used in areas requiring impact protection, this product DOES NOT REQUIRE the use of approved impact resistant shutters or other external protection.
9. Sealing and flashing by others should be applied using the ASTM E 2112 methodology appropriate for the opening into which the door is being installed. Overall water penetration resistance of the installed product is the responsibility of others.
10. Glazing shall comply with ASTM E 1300-04 and safety glazing requirements per FBC Section 2406.
11. For installation to metal substrates, anchors shall be long enough to be fully threaded through the metal thickness with an additional 3/16" min. of threads beyond.
12. A minimum center-to-center spacing of 1-1/4" shall be maintained between all Elco Ultracons in any direction.
13. All fasteners penetrating into pressure treated wood shall be capable of preventing corrosion due to reaction with pressure treatment chemicals. Any dissimilar materials that come into contact shall be protected to prevent reactions in accordance with code requirements.
14. A wind load duration factor Cd = 1.6 was used for the analysis of wood screws only.
15. Windows shall be constructed as specified in test reports A2063.01-501-47-r0, A2065.01-501-47-r0, A4519.01-501-47-r0, A6998.01-501-47-r0, A7004.01-501-47-r0, C9011.01-501-47-r0, D0959.01-501-47-r0, D0960.01-501-47-r0, D7966.01-109-47, and D8114.01-109-47 by Architectural Testing, Inc.

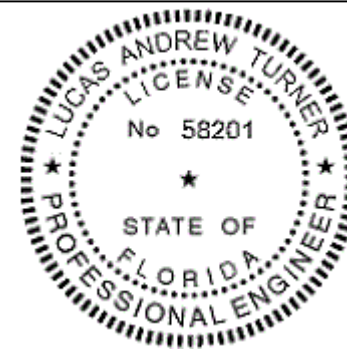

ZZ
5/19/2017
LUCAS A. TURNER, P.E.
FL PE # 58201
TURNER ENGINEERING &
CONSULTING, INC.
(COA # 29779)
1239 JABARA AVE.
NORTH PORT, FL 34288
PH. 941-380-1574

REV. #:	REVISIONS:	REVISED BY:	DATE:
4	CORRECTED LOCATION OF #10 INSTALLATION SCREWS.	T.D.D.	06/02/11
5	ADDED OPTIONAL GLAZING DETAIL.	T.D.D.	11/15/13
6	UPDATED FOR MULTIPLE SUBSTRATE TYPES	L.A.T.	09/06/14
7	ADDED ANNEALED OUTBOARD	L.A.T.	06/30/15
8	ADDED TEST REPORT NUMBERS	LMH	05/16/17

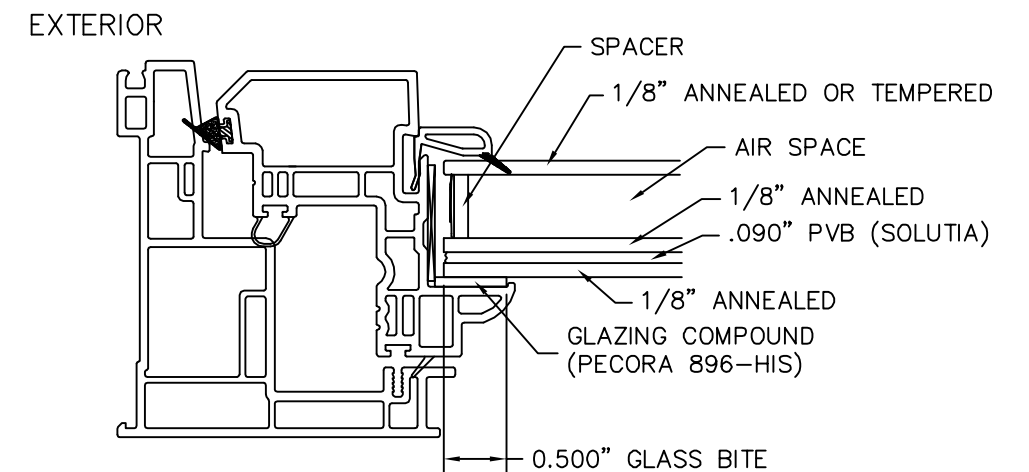

INTERIOR

1" INSULATED TEMPERED/ANNEALED IMPACT GLASS WITH 0.090" PVB INTERLAYER

TABLE 1: INSTALLATION FASTENERS TABLE

ID	SUBSTRATE TYPE	ANCHOR TYPE	MIN. EMBED	MIN. EDGE DIST.
A	CONCRETE (2.85 KSI MIN.)	MAIN FRAME OR HARDWARE: 3/16" ELCO ULTRACON	1"	1"
B	HOLLOW OR GROUT-FILLED CMU (ASTM C90)	MAIN FRAME OR HARDWARE: 3/16" ELCO ULTRACON	1-1/4"	2 1/2"
C	2X MIN. SOUTHERN PINE WOOD (G=0.55)	MAIN FRAME OR HARDWARE: 3/16" ELCO ULTRACON	1-3/8"	3/4"
D	2X MIN. SOUTHERN PINE WOOD (G=0.55)	MAIN FRAME: #10 WOOD SCREW. HARDWARE: #8 WOOD SCREW	1-3/8"	3/4"
E	1/8" ALUM. 6063-T5 MIN. OR 1/8" STEEL 36 KSI MIN.	MAIN FRAME: #10 GRADE 5 SELF-TAPPING/DRILLING SCREW HARDWARE: #8 GRADE 5 SELF-TAPPING/DRILLING SCREW	SEE NOTE 11	1/2"

<p style="text-align: center;">DISCLOSURE STATEMENT</p> <p>This document is the property of Simonton Windows, which retains all proprietary and other rights to its subject matter. This document is provided to the recipient on the expressed condition that it is not to be disclosed, reproduced in whole or part, nor used in conjunction with the design, manufacture or repair of goods for anyone other than Simonton Windows without its consent. This restriction does not limit the recipient's rights to utilize information contained in this document which is properly obtained from another source.</p> <p>FILE: IN0369</p>	<p>MATERIAL:</p> <p>RMS FINISH: EXCEPT AS NOTED</p> <p>ALLOY & TEMPER:</p> <p>WEIGHT: VOLUME:</p> <p>SURFACE AREA: PERIMETER:</p> <p>FINISH TREATMENT:</p>	<p style="text-align: center;">Dimensional Tolerances Unless Otherwise Specified</p> <p>Decimals Angles</p> <p>.X ± .03 .XX ± .01 .XXX ± .005</p> <p>0° 30 min.</p>	<p>SIMONTON WINDOWS</p> <p>1 Cochrane Avenue Pennsboro, WV 26415</p> <p>SCALE: FIT SHEET: 2 of 2</p> <p>SERIES: 08-09 / 08-10 / 08-20 CASEMENT IMPACT WINDOW</p> <p>TITLE: NOTES, GLAZING DETAIL, AND ANCHOR TABLE</p>	<p>SIZE: DRAWING NO.: REV.: B IN0369 8</p> <p>DRAWN BY: DATE: T.D.D. 11/14/08</p> <p>CHECKED BY: DATE:</p> <p>APPR'VD BY: DATE:</p>
--	--	--	--	---