



**3/4-LITE STEEL-EDGE STEEL DOOR UNIT
6'-8" DOUBLE DOOR WITH / WITHOUT SIDELITES**

GENERAL NOTES

1. EVALUATED FOR USE IN LOCATIONS ADHERING TO THE FLORIDA BUILDING CODE AND WHERE PRESSURE REQUIREMENTS AS DETERMINED BY ASCE 7, MINIMUM DESIGN LOADS FOR BUILDINGS AND OTHER STRUCTURES, DOES NOT EXCEED THE DESIGN PRESSURES LISTED.
2. WHEN INSTALLED IN THE HIGH VELOCITY HURRICANE ZONE (HVHZ), HURRICANE PROTECTIVE SYSTEM (SHUTTERS) IS REQUIRED.
3. WHEN INSTALLED IN THE WIND-BORNE DEBRIS REGION, HURRICANE PROTECTIVE SYSTEM (SHUTTERS) IS REQUIRED.
4. POLYURETHANE CORE FLAME SPREAD INDEX OF 50 AND SMOKE DEVELOPED INDEX OF 60 PER ASTM E84.
5. PLASTICS TESTING:

TEST DESCRIPTION	DESIGNATION	LITE FRAME
SELF IGNITION TEMP	ASTM D1929	842 °F > 650 °F
RATE OF BURNING	ASTM D635	1.28 IN/MIN
SMOKE DENSITY	ASTM D2843	70.2%
TENSILE STRENGTH*	ASTM D638	1.8% DIFF

* COMPARATIVE TENSILE STRENGTH AFTER WEATHERING
4500 HOURS XENON ARC METHOD 1

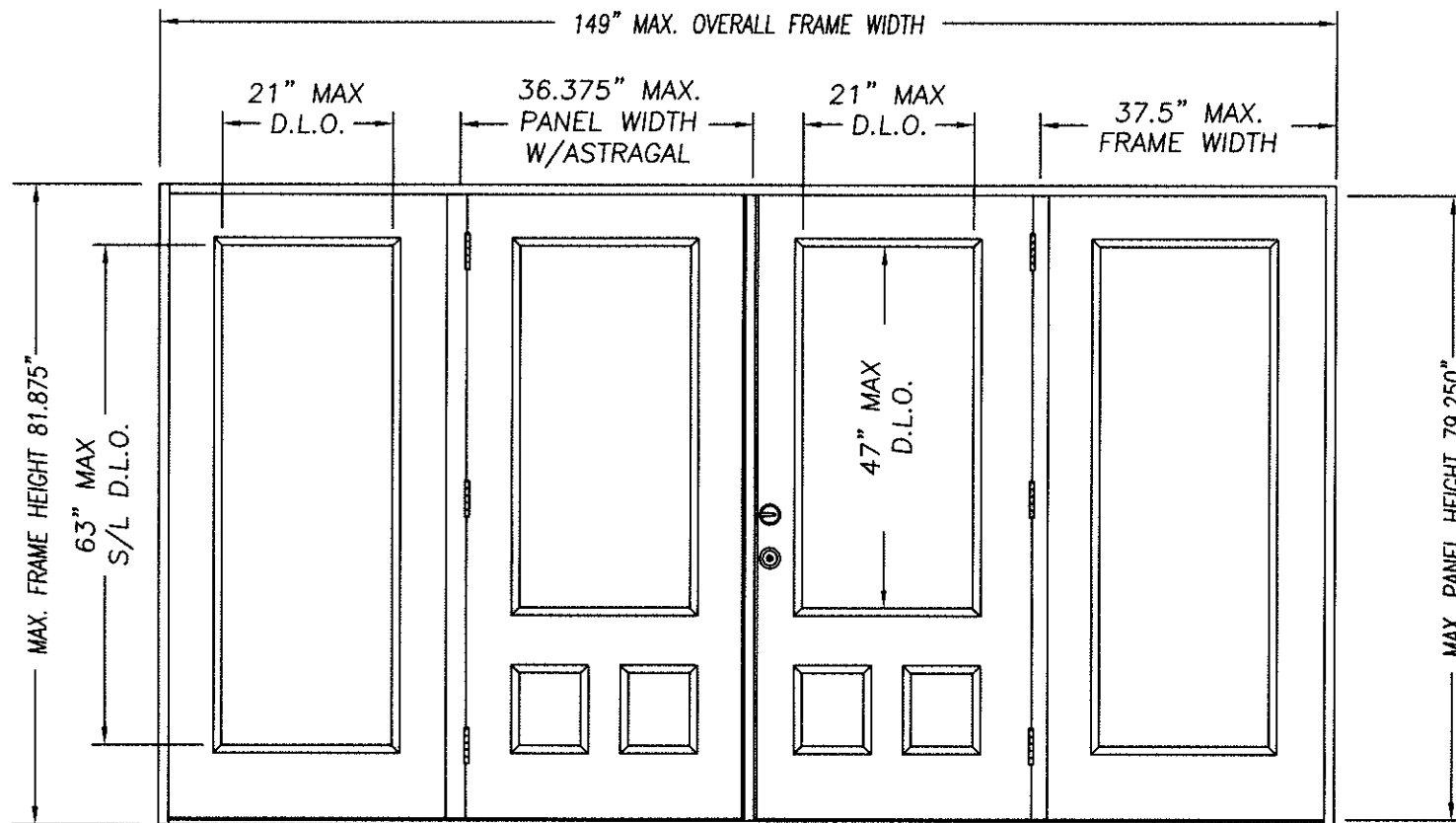

DOUBLE DOOR UNIT W/SIDELITES

Addendum to NAMI

Certification No.: N1013762
Reviewed By: [Signature]
Date Reviewed: 6/24/17

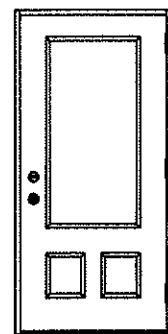

SINGLE DOOR UNIT

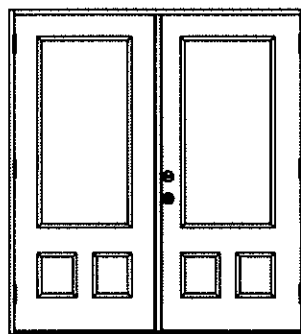

DOUBLE DOOR UNIT

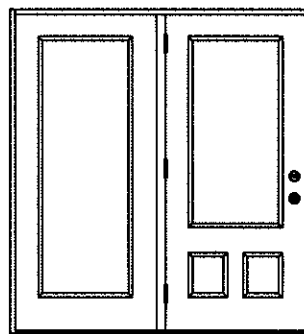

SINGLE DOOR UNIT WITH SIDELITE

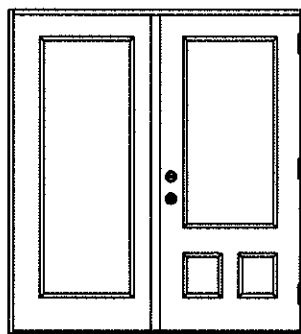

SINGLE DOOR UNIT WITH SIDELITE

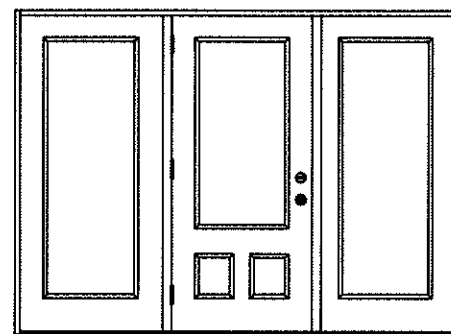

SINGLE DOOR UNIT W/SIDELITES

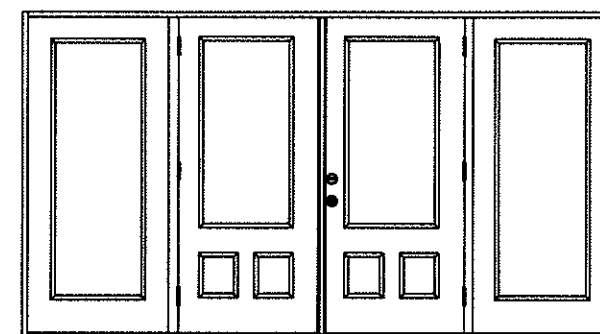

DOUBLE DOOR UNIT W/SIDELITES

TABLE OF CONTENTS

SHEET #	DESCRIPTION
1	TYPICAL ELEVATIONS & GENERAL NOTES
2	ANCHORING LOCATIONS & DETAILS
3	ANCHORING LOCATIONS & DETAILS

CONFIG	MAX WIDTH	DESIGN PRESSURE RATING		WHERE WATER INFILTRATION PERFORMANCE IS REQUIRED TO BE 15% OF DESIGN PRESSURE			
		INSWING	OUTSWING	INSWING	BUMPER O/S	Z-SERIES O/S	HIGH DAM O/S
X	37.5"	+50.0 / -50.0	+50.0 / -50.0	N/A	+25.0 / -25.0	+40.0 / -40.0	+50.0 / -50.0
XX	74"	+50.0 / -50.0	+50.0 / -50.0	N/A	+25.0 / -25.0	+40.0 / -40.0	+50.0 / -50.0
OX or XO	75"	+50.0 / -50.0	+50.0 / -50.0	N/A	+25.0 / -25.0	+40.0 / -40.0	+50.0 / -50.0
OXO	112.5"	+50.0 / -50.0	+50.0 / -50.0	N/A	+25.0 / -25.0	+40.0 / -40.0	+50.0 / -50.0
OXO	149"	+50.0 / -50.0	+50.0 / -50.0	N/A	+25.0 / -25.0	+40.0 / -40.0	+50.0 / -50.0

[Signature]

KURT BALTHAZOR
FLORIDA P.E.
#56533

PRODUCT: "EXTERIOR DOOR PRODUCT"
DOUBLE 6'8" GLAZED
STEEL-EDGE STEEL DOOR
PART OR ASSEMBLY:
TYPICAL ELEVATIONS
& GENERAL NOTES

NO.	DATE	BY	REVISIONS

DATE: 6/21/17

SCALE: N.T.S.

DWG. BY: SWS

CHK. BY:

DRAWING NO.:

DWG-MA-FL0219-17

SHEET 1 OF 3

MASONITE INTERNATIONAL CORP.
1955 POWIS ROAD
WEST CHICAGO, IL 60185

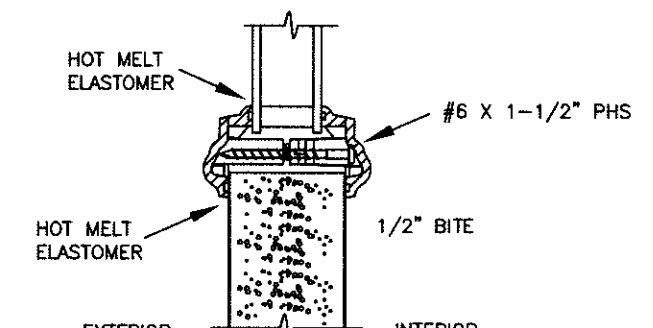
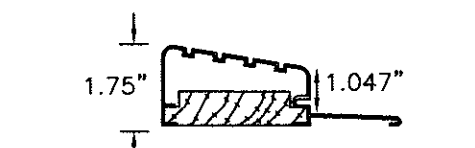
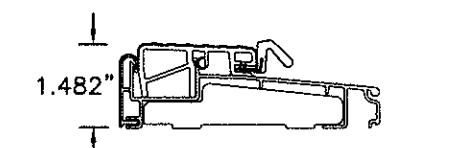
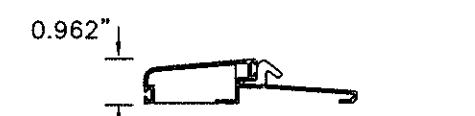
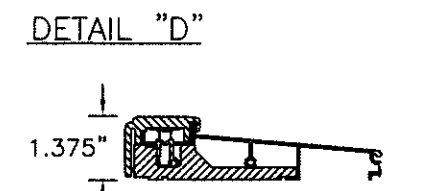
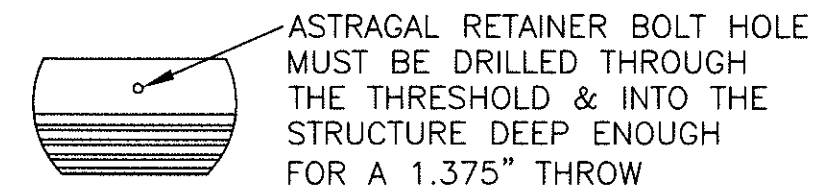
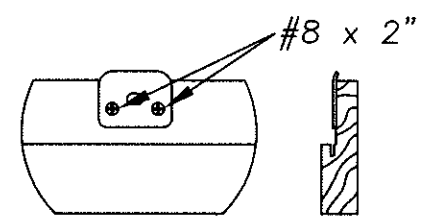
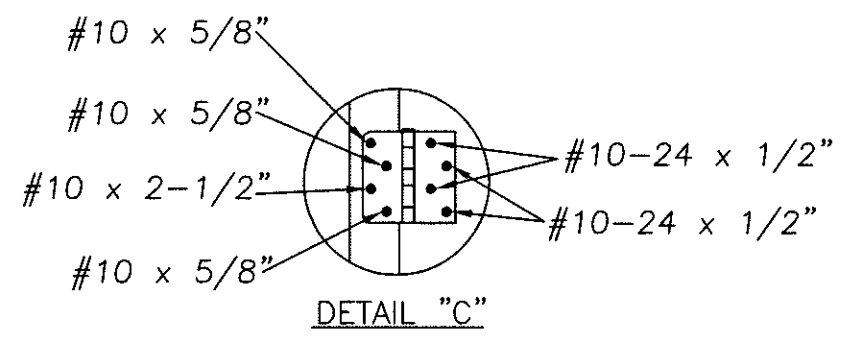
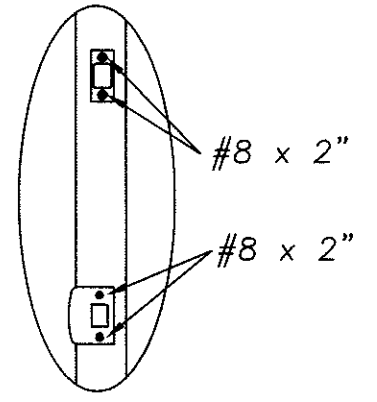
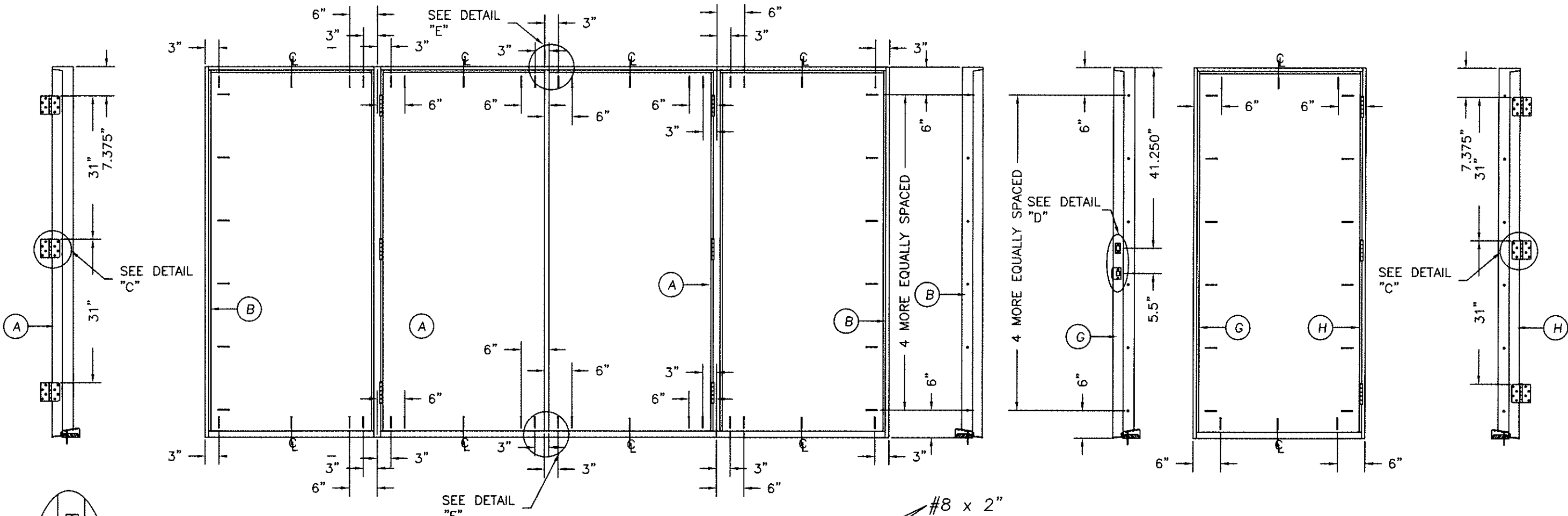

DETAIL "E" ASTRAGAL
ATTACH ASTRAGAL RETAINER BOLT STRIKE PLATE TO FRAME AS SHOWN.

DETAIL "F" ASTRAGAL

TYPICAL GLAZING DETAIL
NON-IMPACT GLASS

MASONITE INTERNATIONAL CORP.
1955 POWIS ROAD
WEST CHICAGO, IL 60185

PRODUCT:
"EXTERIOR DOOR PRODUCT"
6'-8" STEEL-EDGE STEEL GLAZED
DOUBLE DOOR UNIT
PART OR ASSEMBLY:
ANCHORING LOCATIONS
& DETAILS

REVISIONS		
NO.	DATE	BY

Addendum to NAMI

Certification No.: NI013762
Reviewed By: [Signature]
Date Reviewed: 6/24/17

DATE: 6/21/17
SCALE: N.T.S.
DWG. BY: SWS
CHK. BY:
DRAWING NO.:
DWG-MA-FLO219-17
SHEET 2 OF 3

Z-SERIES O/S THRESHOLD HIGH DAM O/S THRESHOLD

PRODUCT:	EXTERIOR DOOR PRODUCT 6'-8" STEEL-EDGE STEEL GLAZED DOUBLE DOOR UNIT
PART OR ASSEMBLY:	ANCHORING LOCATIONS & DETAILS
NO.	BY
DATE	REVISIONS

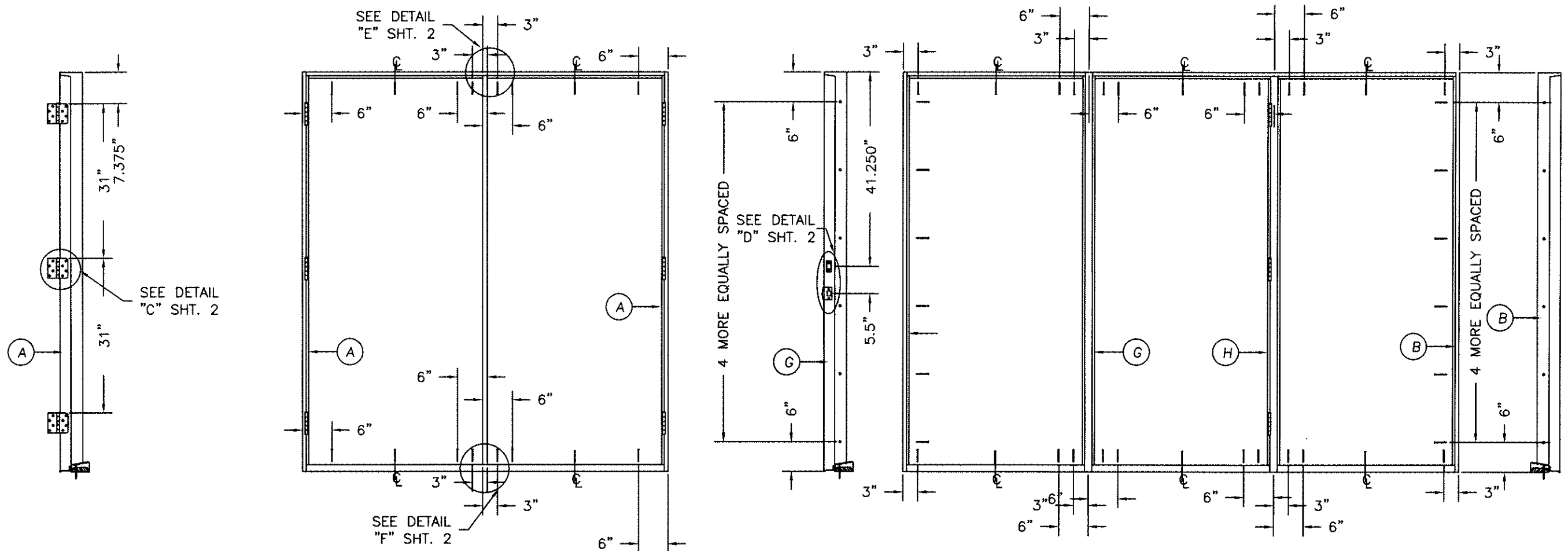

HARDWARE SCHEDULE

- KWIKSET SERIES 400 GRADE 3 CYLINDRICAL LATCH AND SERIES 980 GRADE 1 DEADLOCK HARDWARE TO BE INSTALLED AT 5-1/2" CENTERLINE.
- 4" X 4" FULL MORTISE BUTT HINGES.

ATTACHMENT DETAIL

- ANCHOR ANALYSIS FOR LOADING CONDITIONS PREPARED, SIGNED AND SEALED BY ROBERTO LOMAS, PE (FLORIDA #62514) WITH THE LOWEST (LEAST) FASTENER RATING FROM THE DIFFERENT FASTENERS BEING CONSIDERED FOR USE. JAMB, HEAD, AND THRESHOLD FASTENERS ANALYZED FOR THIS UNIT INCLUDE #10 WOOD SCREWS OR 1/4" TAPCONS. A PHYSICAL SHIM MUST BE PLACED IN SHIM SPACE AT EACH ANCHOR LOCATION. TAPCON EDGE DISTANCE MIN 2-1/2". WOOD SCREW EDGE DISTANCE MIN 3/4".
- THE WOOD SCREW SINGLE SHEAR DESIGN VALUES COME FROM ANSI/AF&PA NDA FOR SOUTHERN PINE LUMBER AND ACHIEVEMENT OF 1-1/2" MINIMUM EMBEDMENT. THE TAPCON MUST ACHIEVE MINIMUM EMBEDMENT OF 1-1/4".
- WOOD BUCKS BY OTHERS MUST BE ANCHORED PROPERLY TO TRANSFER LOADS TO STRUCTURE.
- MINIMUM DESIGN VALUE STRENGTH OF ANCHORS 155 LBS.

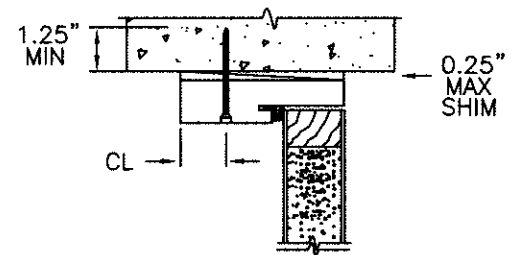

TYPICAL MASONRY ANCHOR INSTALLATION

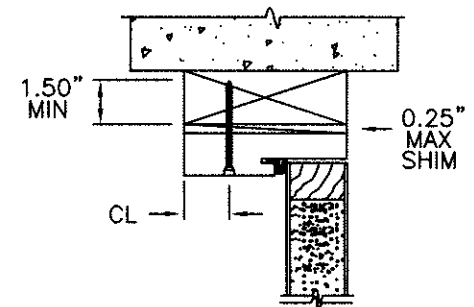

TYPICAL WOOD BUCK ANCHOR INSTALLATION

1"X1/2" CORRUGATED
3" FROM EACH END
AND 7" OC

#10X2" WOOD SCREW
6" FROM EACH END
AND 12" OC

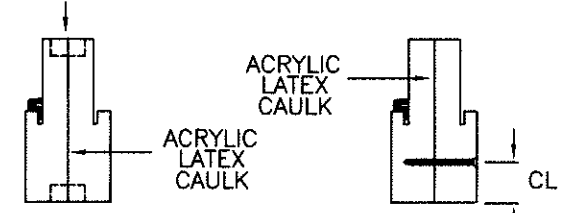

COMBINATION WOOD MULLION (BOXED)

(3) #10X2-1/2"
WOOD SCREWS
EACH END

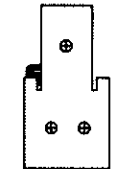

INTEGRAL WOOD MULLION (CHS)

Addendum to NAMI

Certification No.: NE013762
Reviewed By: [Signature]
Date Reviewed: 6/26/17

DATE:	6/21/17
SCALE:	N.T.S.
DWG. BY:	SWS
CHK. BY:	
DRAWING NO.:	
DWG-MA-FLO219-17	
SHEET	3 OF 3