



STEEL-EDGE STEEL DOOR UNIT
8'-0" DOUBLE DOOR WITH / WITHOUT SIDELITES

GENERAL NOTES

- EVALUATED FOR USE IN LOCATIONS ADHERING TO THE FLORIDA BUILDING CODE AND WHERE PRESSURE REQUIREMENTS AS DETERMINED BY ASCE 7, MINIMUM DESIGN LOADS FOR BUILDINGS AND OTHER STRUCTURES, DOES NOT EXCEED THE DESIGN PRESSURES LISTED.
- HURRICANE PROTECTIVE SYSTEM (SHUTTERS) IS NOT REQUIRED ON OPAQUE PANELS, BUT IS REQUIRED ON GLAZED SIDELITES.
- WHEN INSTALLED IN THE WIND-BORNE DEBRIS REGION, EXCLUDING THE HIGH VELOCITY HURRICANE ZONE (HVHZ), HURRICANE PROTECTIVE SYSTEM IS NOT REQUIRED ON OPAQUE PANELS OR PANELS WITH IMPACT GLASS, BUT IS REQUIRED ON PANELS WITH NON-IMPACT GLASS.
- POLYURETHANE CORE FLAME SPREAD INDEX OF 50 AND SMOKE DEVELOPED INDEX OF 60 PER ASTM E84.
- PLASTICS TESTING:

TEST DESCRIPTION	DESIGNATION	LITE FRAME
SELF IGNITION TEMP	ASTM D1929	842 °F > 650 °F
RATE OF BURNING	ASTM D635	1.28 IN/MIN
SMOKE DENSITY	ASTM D2843	70.2%
TENSILE STRENGTH*	ASTM D638	1.8% DIFF

* COMPARATIVE TENSILE STRENGTH AFTER WEATHERING 4500 HOURS XENON ARC METHOD 1

Addendum to NAMI

Certification No.: NE013762
 Reviewed By: [Signature]
 Date Reviewed: 6/26/17

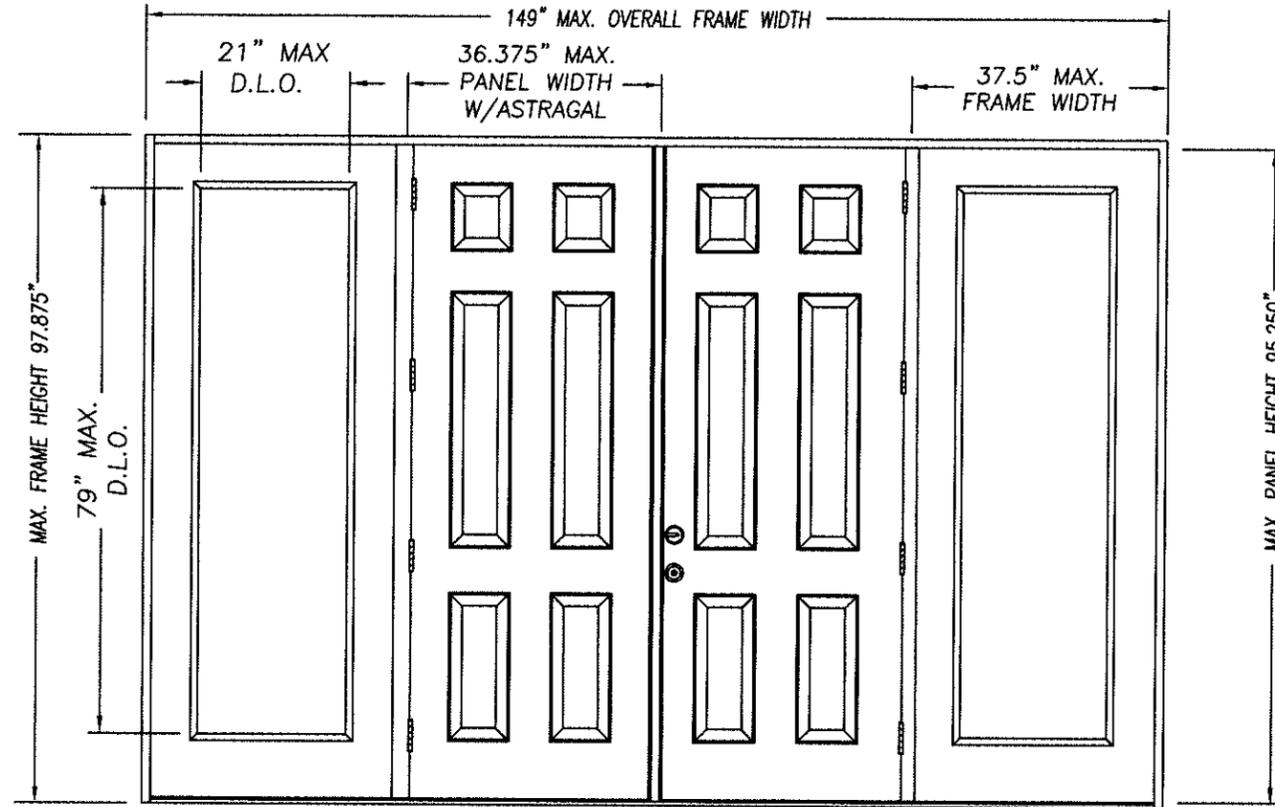

DOUBLE DOOR UNIT W/SIDELITES

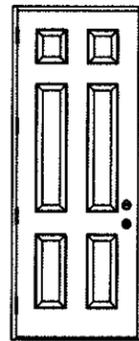

SINGLE DOOR UNIT

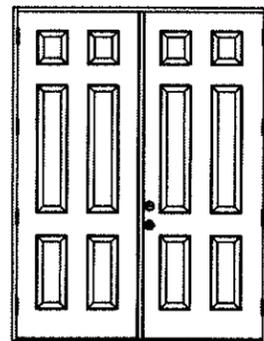

DOUBLE DOOR UNIT

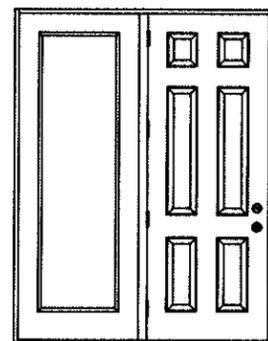

SINGLE DOOR UNIT WITH SIDELITE

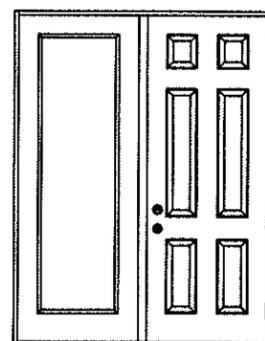

SINGLE DOOR UNIT WITH SIDELITE

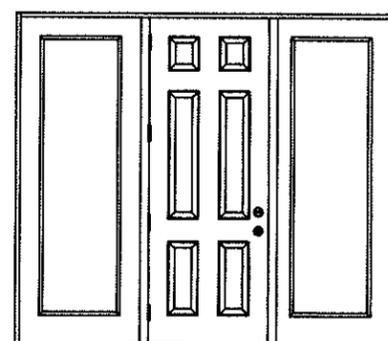

SINGLE DOOR UNIT W/SIDELITES

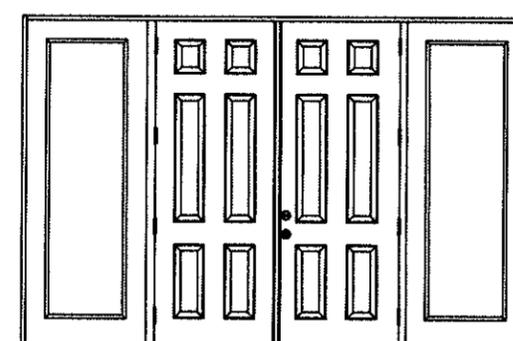

DOUBLE DOOR UNIT W/SIDELITES

TABLE OF CONTENTS

SHEET #	DESCRIPTION
1	TYPICAL ELEVATIONS & GENERAL NOTES
2	ANCHORING LOCATIONS & DETAILS
3	ANCHORING LOCATIONS & DETAILS

CONFIG	MAX WIDTH	DESIGN PRESSURE RATING		WHERE WATER INFILTRATION PERFORMANCE IS REQUIRED TO BE 15% OF DESIGN PRESSURE			
		INSWING	OUTSWING	INSWING	BUMPER O/S	Z-SERIES O/S	HIGH DAM O/S
X	37.5"	+48.0 / -48.0	+48.0 / -48.0	N/A	+25.0 / -25.0	+40.0 / -40.0	+48.0 / -48.0
XX	74"	+48.0 / -48.0	+48.0 / -48.0	N/A	+25.0 / -25.0	+40.0 / -40.0	+48.0 / -48.0
OX or XO	75"	+48.0 / -48.0	+48.0 / -48.0	N/A	+25.0 / -25.0	+40.0 / -40.0	+48.0 / -48.0
OXO	112.5"	+48.0 / -48.0	+48.0 / -48.0	N/A	+25.0 / -25.0	+40.0 / -40.0	+48.0 / -48.0
OX XO	149"	+48.0 / -48.0	+48.0 / -48.0	N/A	+25.0 / -25.0	+40.0 / -40.0	+48.0 / -48.0

Kurt Balthazor

KURT BALTHAZOR
 FLORIDA P.E.
 #56533

NO.	DATE	REVISIONS	BY

DATE: 6/21/17
 SCALE: N.T.S.
 DWG. BY: SWS
 CHK. BY:
 DRAWING NO.:
 DWG-MA-FL0224-17
 SHEET 1 OF 3

PRODUCT: EXTERIOR DOOR PRODUCT
 DOUBLE 8'0" OPAQUE
 STEEL-EDGE STEEL DOOR
 PART OR ASSEMBLY:
 TYPICAL ELEVATIONS
 & GENERAL NOTES

MASONITE INTERNATIONAL CORP.
 1955 POWIS ROAD
 WEST CHICAGO, IL 60185

MASONITE INTERNATIONAL CORP.
 1955 POWIS ROAD
 WEST CHICAGO, IL 60185

PRODUCT:
 "EXTERIOR DOOR PRODUCT"
 8'0" STEEL-EDGE STEEL OPAQUE
 DOUBLE DOOR UNIT
 PART OR ASSEMBLY:
 ANCHORING LOCATIONS
 & DETAILS

NO.	DATE	BY	REVISIONS

DATE: 6/21/17
 SCALE: N.T.S.
 DWG. BY: SWS
 CHK. BY:
 DRAWING NO.:
 DWG-MA-FL0224-17
 SHEET 2 OF 3

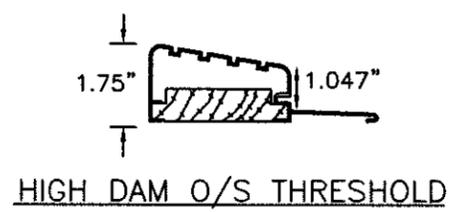
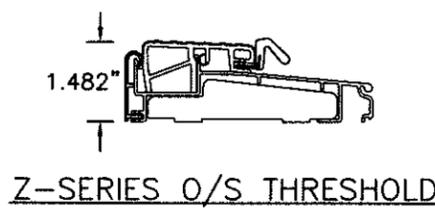
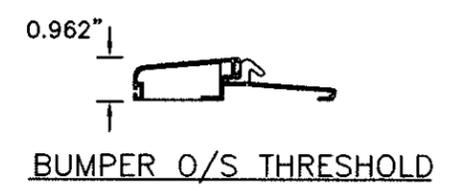
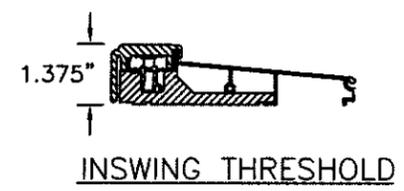
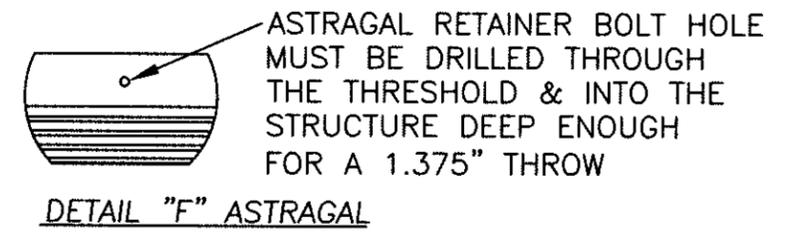
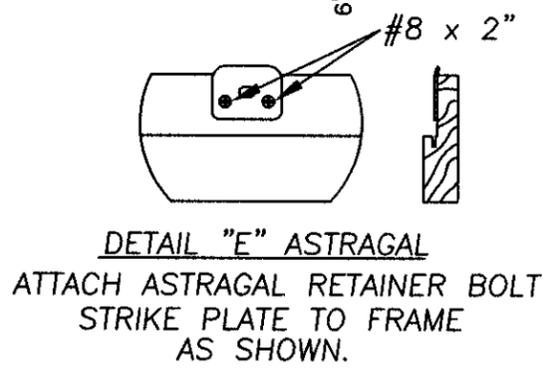
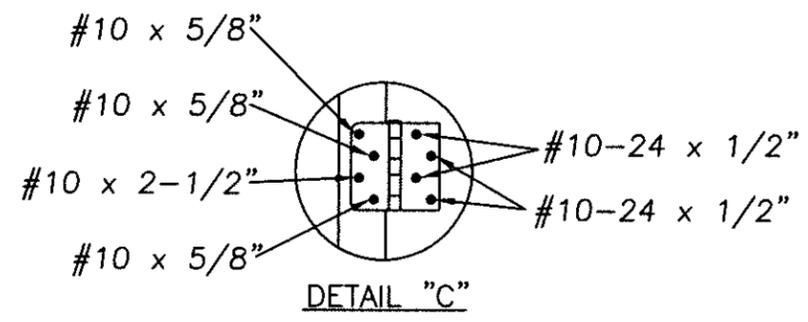
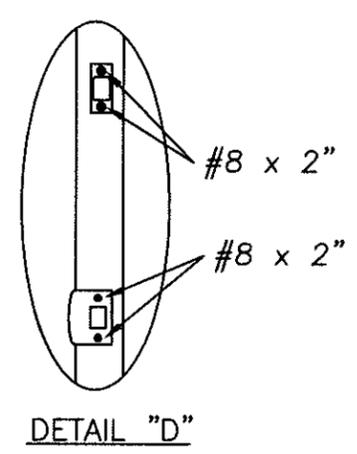
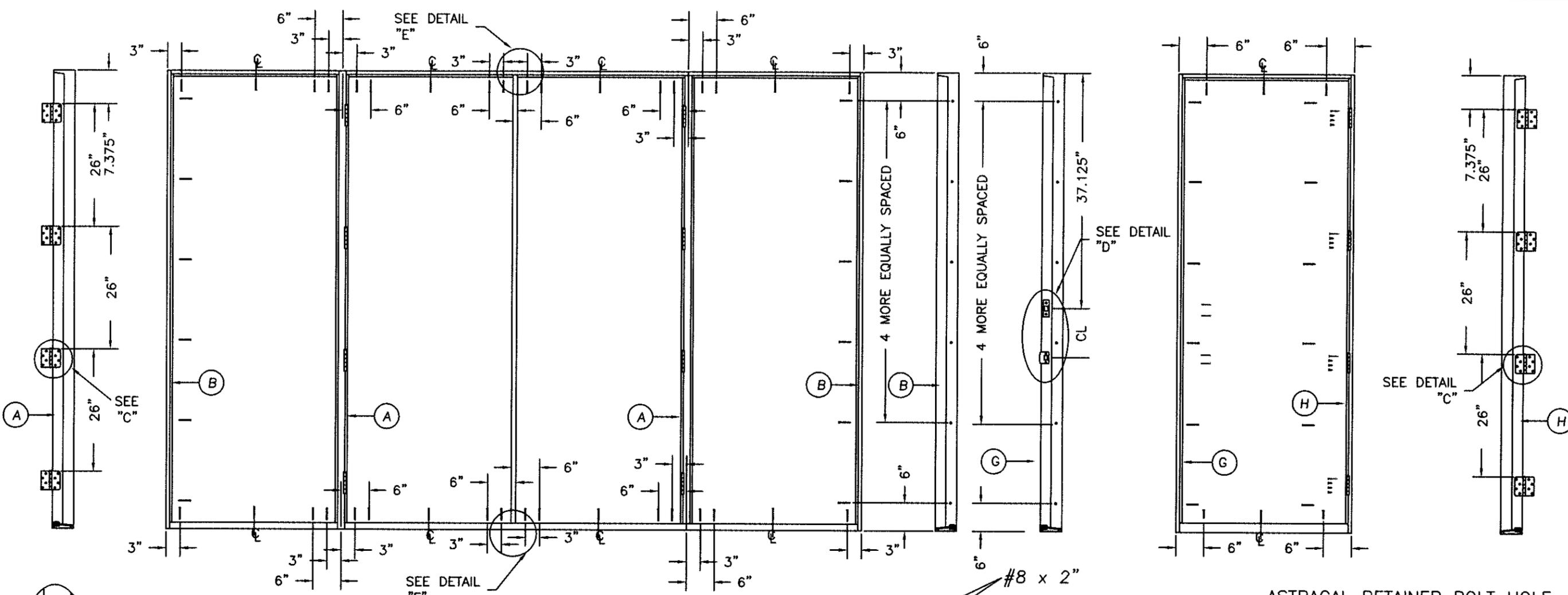

Addendum to NAMI
 Certification No.: N1013762
 Reviewed By: *[Signature]*
 Date Reviewed: 6/21/17

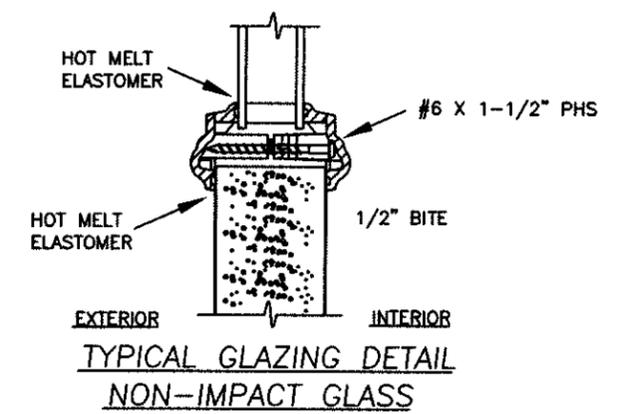

MASONITE INTERNATIONAL CORP.
 1955 POWIS RD.
 WEST CHICAGO, IL 60185

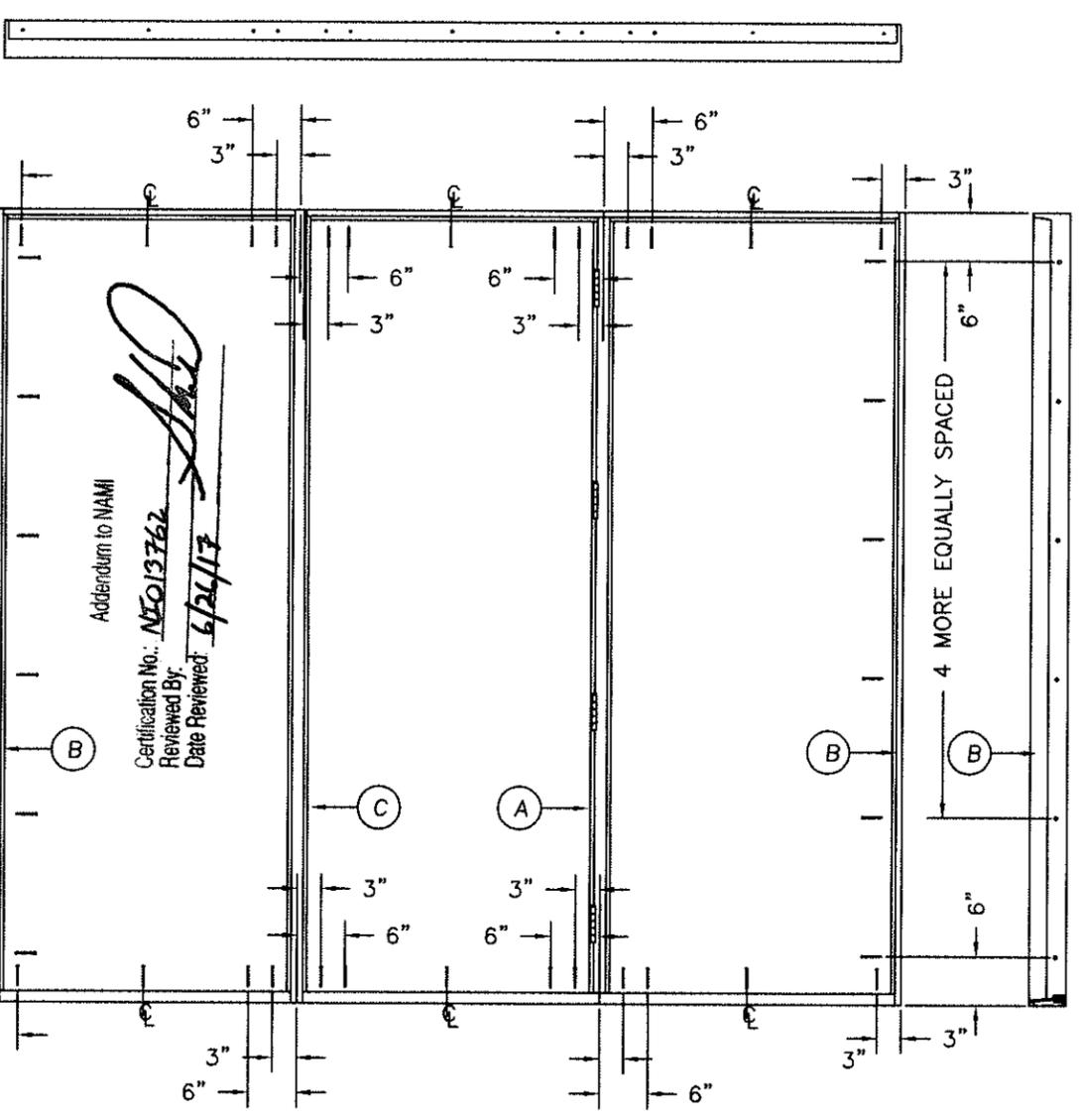
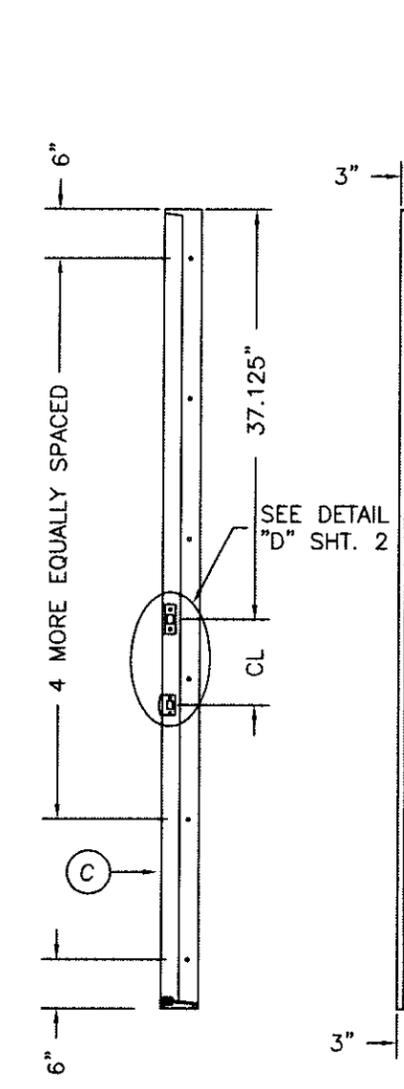
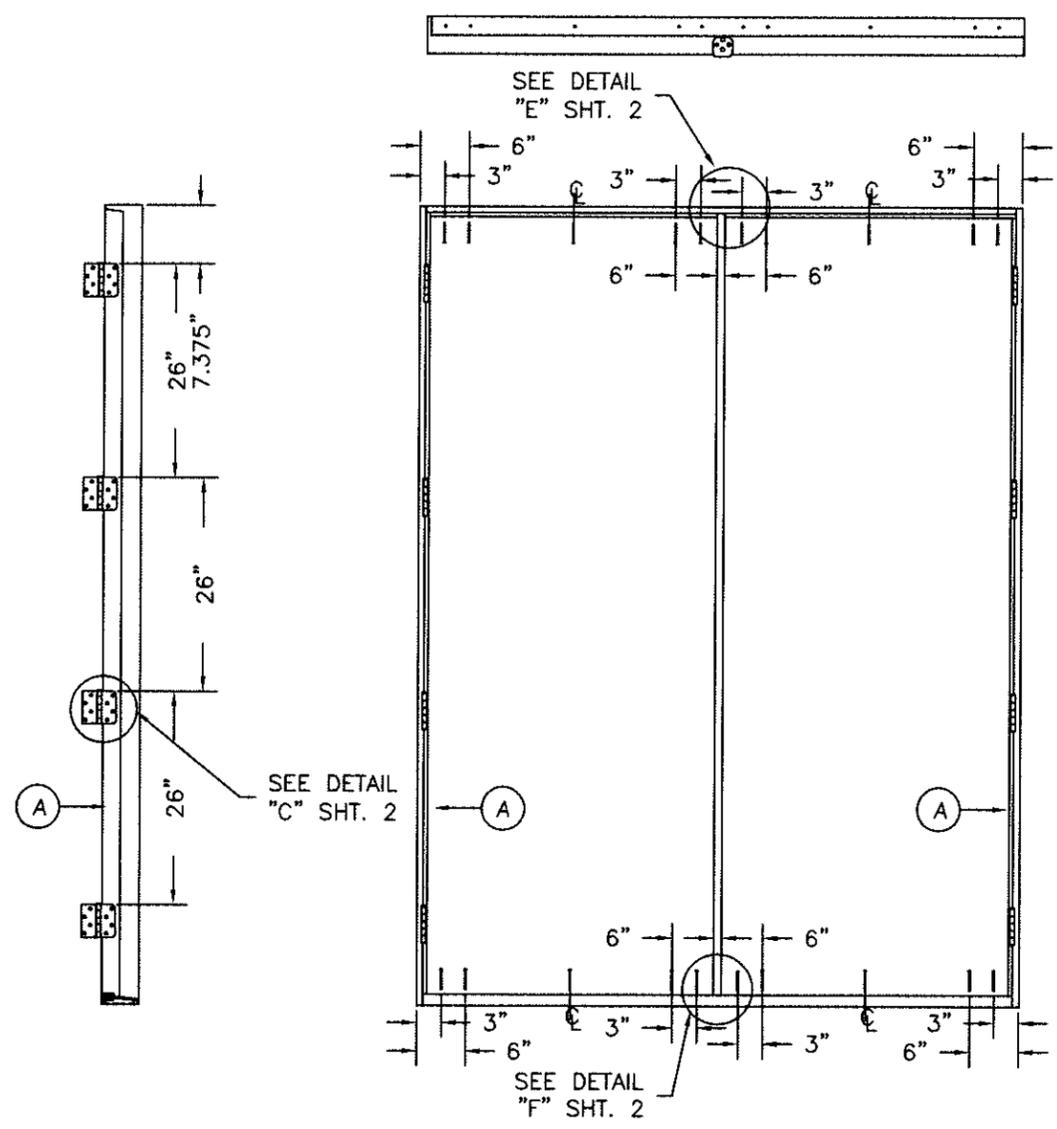

Addendum to NAMI
 Certification No.: *NEQ13762*
 Reviewed By: *[Signature]*
 Date Reviewed: *6/24/17*

ATTACHMENT DETAIL

1. ANCHOR ANALYSIS FOR LOADING CONDITIONS PREPARED, SIGNED AND SEALED BY LUIS R. LOMAS, PE (FLORIDA #62514) WITH THE LOWEST (LEAST) FASTENER RATING FROM THE DIFFERENT FASTENERS BEING CONSIDERED FOR USE. JAMB, HEAD, AND THRESHOLD FASTENERS ANALYZED FOR THIS UNIT INCLUDE #10 WOOD SCREWS OR 1/4" TAPCONS. A PHYSICAL SHIM MUST BE PLACED IN SHIM SPACE AT EACH ANCHOR LOCATION. TAPCON EDGE DISTANCE MIN 2-1/2". WOOD SCREW EDGE DISTANCE MIN 3/4".
2. THE WOOD SCREW SINGLE SHEAR DESIGN VALUES COME FROM ANSI/AF&PA NDA FOR SOUTHERN PINE LUMBER AND ACHIEVEMENT OF 1-1/2" MINIMUM EMBEDMENT. THE TAPCON MUST ACHIEVE MINIMUM EMBEDMENT OF 1-1/4".
3. WOOD BUCKS BY OTHERS MUST BE ANCHORED PROPERLY TO TRANSFER LOADS TO STRUCTURE.
4. MINIMUM DESIGN VALUE STRENGTH OF ANCHORS 155 LBS.

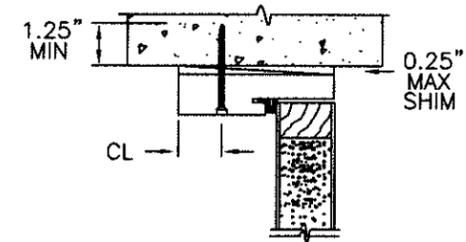

TYPICAL MASONRY ANCHOR INSTALLATION

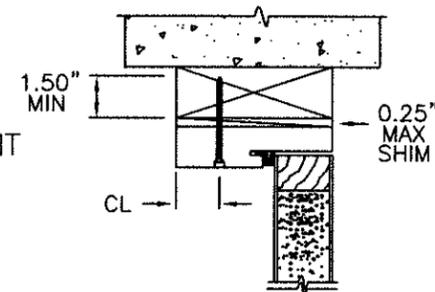

TYPICAL WOOD BUCK ANCHOR INSTALLATION

HARDWARE SCHEDULE

1.	KWIKSET SERIES 400 GRADE 3 CYLINDRICAL LATCH AND SERIES 980 GRADE 1 DEADLOCK HARDWARE TO BE INSTALLED AT 10-1/2" CENTERLINE.
2.	4" X 4" FULL MORTISE BUTT HINGES.

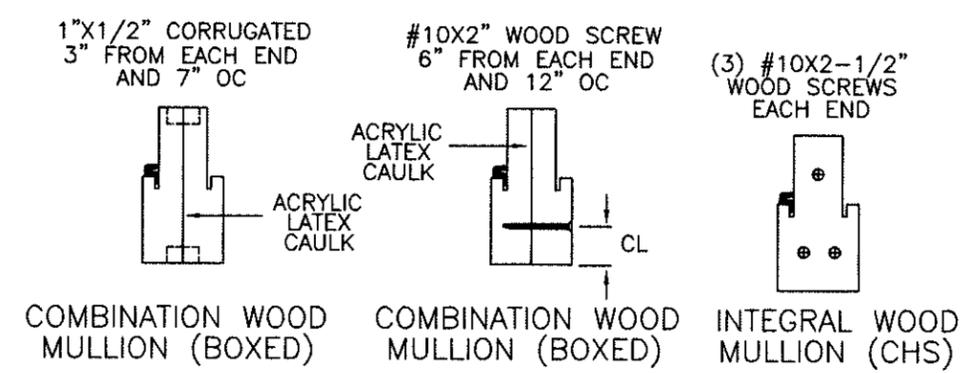

PRODUCT:
 "EXTERIOR DOOR PRODUCT"
 8'0" STEEL-EDGE STEEL OPAQUE
 DOUBLE DOOR UNIT
 PART OR ASSEMBLY:
 ANCHORING LOCATIONS
 & DETAILS

NO.	DATE	BY	REVISIONS

DATE: 6/21/17
 SCALE: N.T.S.
 DWG. BY: SWS
 CHK. BY:
 DRAWING NO.:
 DWG-MA-FL0224-17
 SHEET 3 OF 3