



**HPC IMPACT GLAZED STEEL-EDGE STEEL DOOR UNIT
6'-8" DOUBLE DOOR WITH / WITHOUT SIDELITES**

GENERAL NOTES

- EVALUATED FOR USE IN LOCATIONS ADHERING TO THE FLORIDA BUILDING CODE AND WHERE PRESSURE REQUIREMENTS AS DETERMINED BY ASCE 7, MINIMUM DESIGN LOADS FOR BUILDINGS AND OTHER STRUCTURES, DOES NOT EXCEED THE DESIGN PRESSURES LISTED.
- WHEN INSTALLED IN THE HIGH VELOCITY HURRICANE ZONE (HVHZ), HURRICANE PROTECTIVE SYSTEM (SHUTTERS) IS NOT REQUIRED.
- WHEN INSTALLED IN THE WIND-BORNE DEBRIS REGION, HURRICANE PROTECTIVE SYSTEM (SHUTTERS) IS NOT REQUIRED.
- POLYURETHANE CORE FLAME SPREAD INDEX OF 50 AND SMOKE DEVELOPED INDEX OF 60 PER ASTM E84.
- PLASTICS TESTING:

TEST DESCRIPTION	DESIGNATION	LITE FRAME
SELF IGNITION TEMP	ASTM D1929	842 °F > 650 °F
RATE OF BURNING	ASTM D635	1.28 IN/MIN
SMOKE DENSITY	ASTM D2843	70.2%
TENSILE STRENGTH*	ASTM D638	1.8% DIFF

* COMPARATIVE TENSILE STRENGTH AFTER WEATHERING 4500 HOURS XENON ARC METHOD 1
- DOOR SLABS MUST BE STAMPED "HPC" ON TOP RAIL.

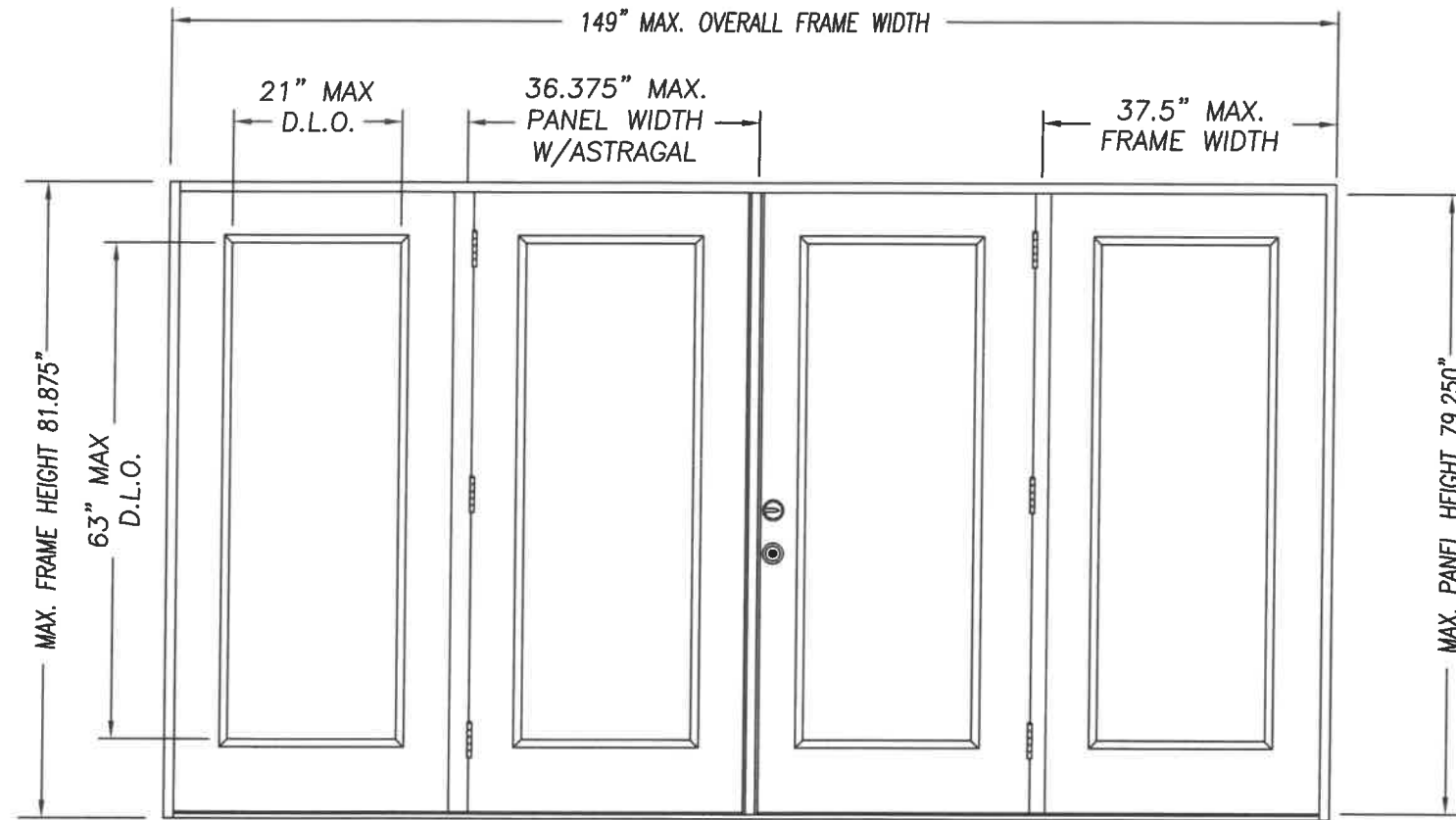

DOUBLE DOOR UNIT W/SIDELITES

Addendum to NAMI

Certification No.: NS013762
 Reviewed By: [Signature]
 Date Reviewed: 10/25/17



SINGLE DOOR UNIT

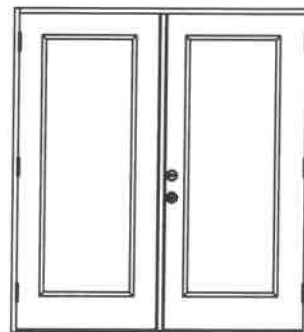

DOUBLE DOOR UNIT

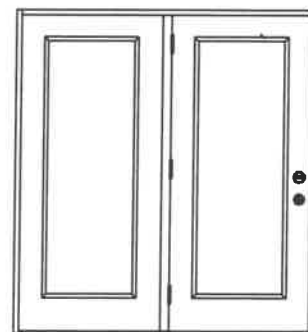

SINGLE DOOR UNIT WITH SIDELITE

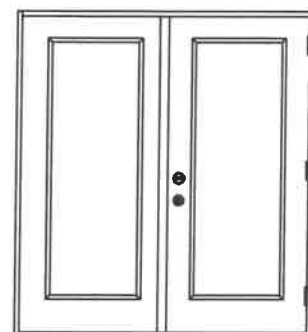

SINGLE DOOR UNIT WITH SIDELITE

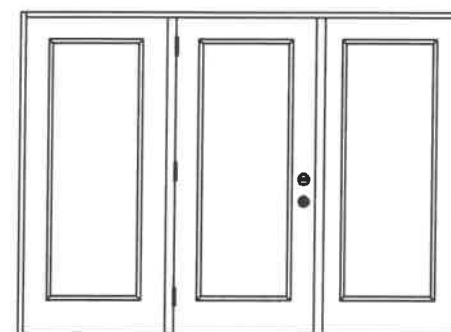

SINGLE DOOR UNIT W/SIDELITES

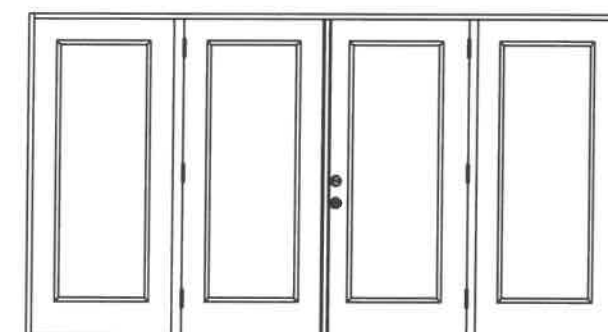

DOUBLE DOOR UNIT W/SIDELITES

TABLE OF CONTENTS

SHEET #	DESCRIPTION
1	TYPICAL ELEVATIONS & GENERAL NOTES
2	ANCHORING LOCATIONS & DETAILS
3	ANCHORING LOCATIONS & DETAILS

CONFIG	MAX WIDTH	DESIGN PRESSURE RATING		WHERE WATER INFILTRATION PERFORMANCE IS REQUIRED TO BE 15% OF DESIGN PRESSURE			
		INSWING	OUTSWING	INSWING	BUMPER O/S	Z-SERIES O/S	HIGH DAM O/S
X	37.5"	+50.0 / -50.0	+50.0 / -50.0	N/A	+25.0 / -25.0	+40.0 / -40.0	+50.0 / -50.0
XX	74"	+50.0 / -50.0	+50.0 / -50.0	N/A	+25.0 / -25.0	+40.0 / -40.0	+50.0 / -50.0
OX or XO	75"	+50.0 / -50.0	+50.0 / -50.0	N/A	+25.0 / -25.0	+40.0 / -40.0	+50.0 / -50.0
OXO	112.5"	+50.0 / -50.0	+50.0 / -50.0	N/A	+25.0 / -25.0	+40.0 / -40.0	+50.0 / -50.0
OX XO	149"	+50.0 / -50.0	+50.0 / -50.0	N/A	+25.0 / -25.0	+40.0 / -40.0	+50.0 / -50.0

Kurt Balthazor

KURT BALTHAZOR
FLORIDA P.E.
#56533

PRODUCT: EXTERIOR DOOR PRODUCT
DOUBLE 6'-8" GLAZED
STEEL-EDGE STEEL DOOR
PART OR ASSEMBLY:
TYPICAL ELEVATIONS
& GENERAL NOTES

NO.	DATE	REVISIONS	BY

DATE: 6/21/17
 SCALE: N.T.S.
 DWG. BY: SWS
 CHK. BY:
 DRAWING NO.:
 DWG-MA-FLO223-17
 SHEET 1 OF 3

MASONITE INTERNATIONAL CORP.
1955 POWIS ROAD
WEST CHICAGO, IL 60185

MASONITE INTERNATIONAL CORP.
 1955 POWIS ROAD
 WEST CHICAGO, IL 60185

PRODUCT: EXTERIOR DOOR PRODUCT
 6'-8" STEEL-EDGE STEEL GLAZED
 DOUBLE DOOR UNIT
 PART OR ASSEMBLY:
 ANCHORING LOCATIONS
 & DETAILS

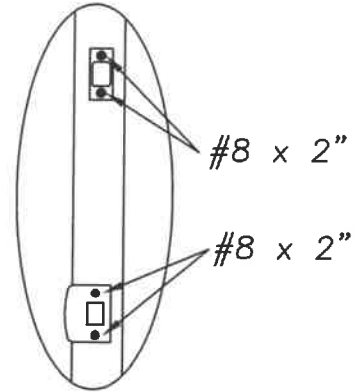
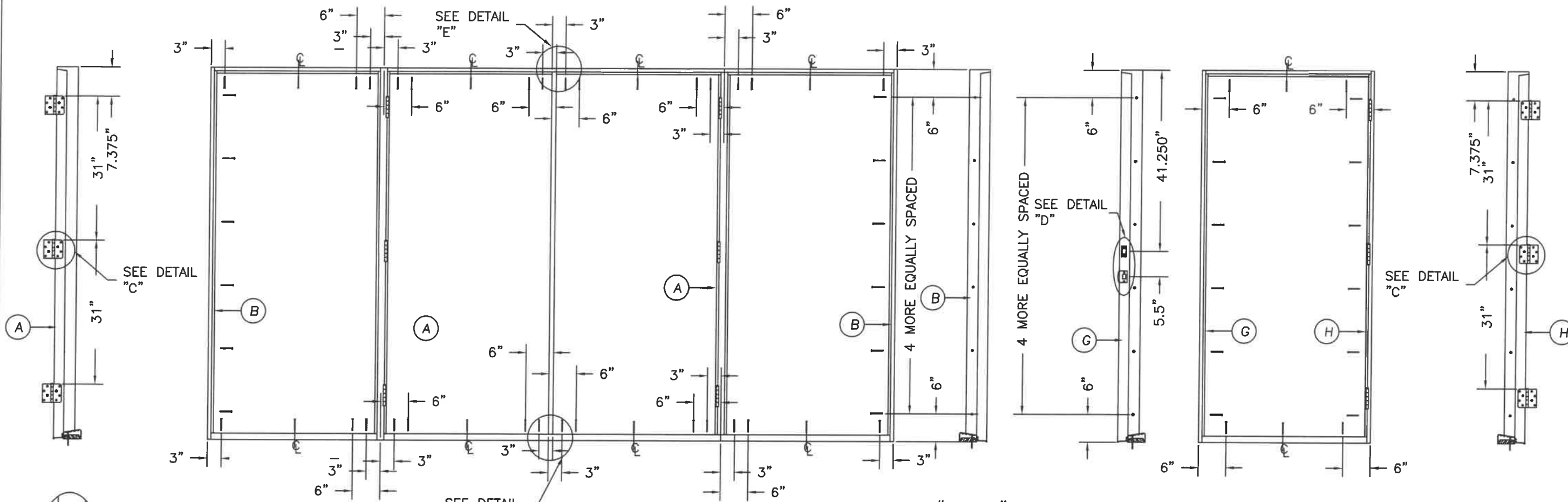

DETAIL "D"

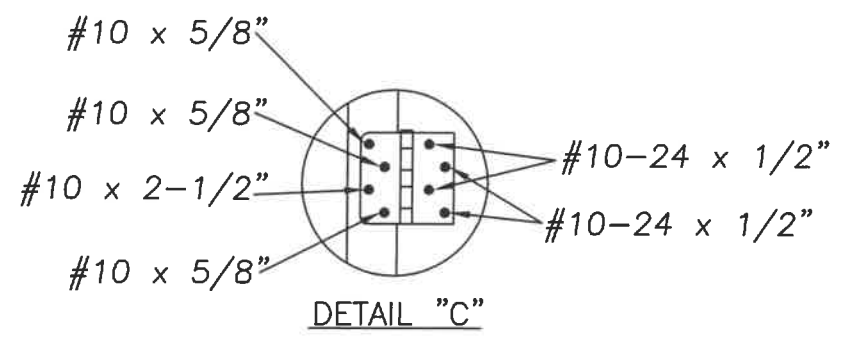

DETAIL "C"

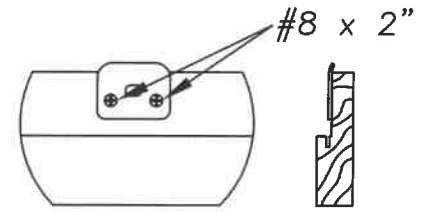

DETAIL "E" ASTRAGAL
 ATTACH ASTRAGAL RETAINER BOLT
 STRIKE PLATE TO FRAME
 AS SHOWN.

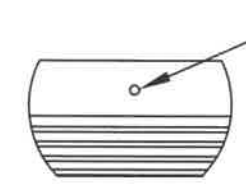

DETAIL "F" ASTRAGAL

ASTRAGAL RETAINER BOLT HOLE
 MUST BE DRILLED THROUGH
 THE THRESHOLD & INTO THE
 STRUCTURE DEEP ENOUGH
 FOR A 1.375" THROW

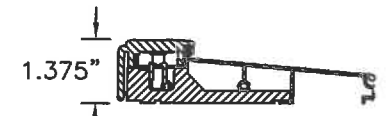

INSWING THRESHOLD



BUMPER O/S THRESHOLD

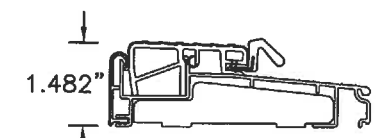

Z-SERIES O/S THRESHOLD

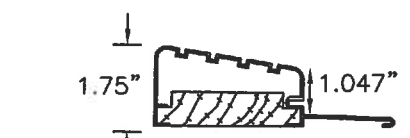

HIGH DAM O/S THRESHOLD

Addendum to NAMI
 Certification No.: NE013762
 Reviewed By: [Signature]
 Date Reviewed: 6/26/17

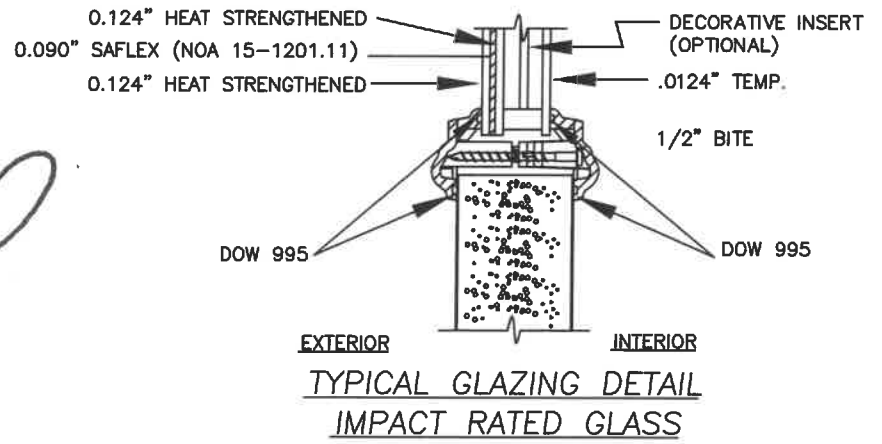

EXTERIOR INTERIOR
 TYPICAL GLAZING DETAIL
 IMPACT RATED GLASS

NO.	DATE	REVISIONS	BY

DATE: 6/21/17
 SCALE: N.T.S.
 DWG. BY: SWS
 CHK. BY:
 DRAWING NO.:
 DWG-MA-FL0223-17
 SHEET 2 OF 3

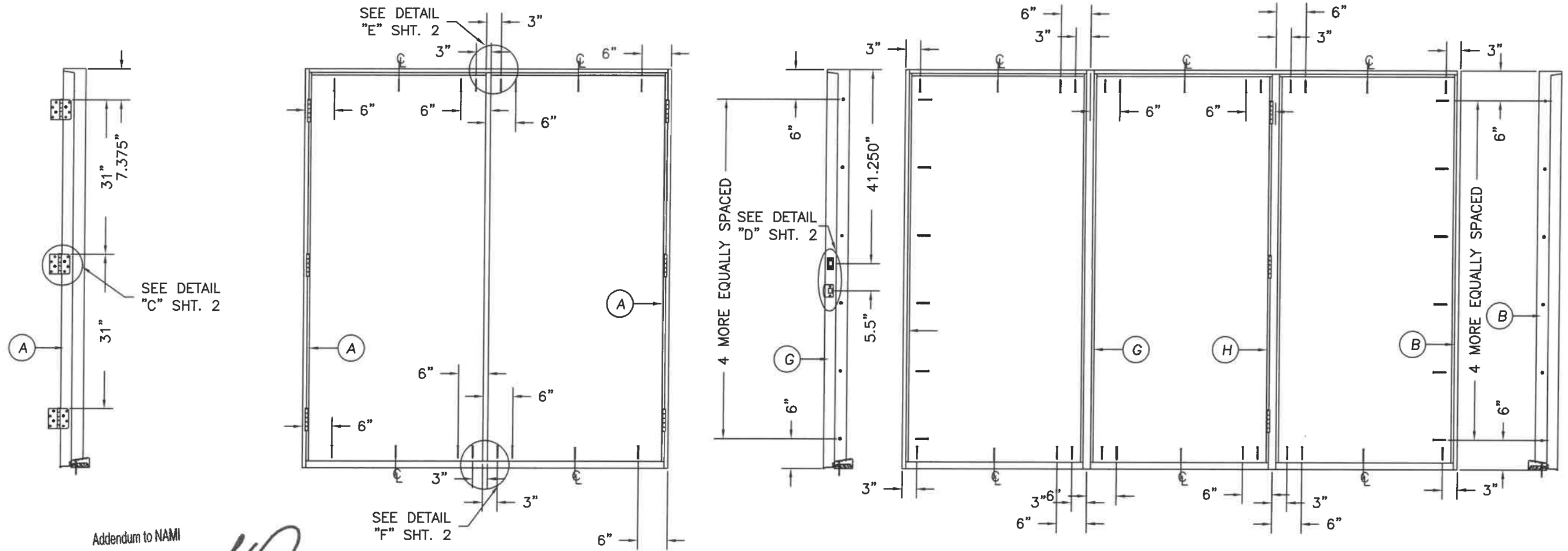

Addendum to NAMI

Certification No.: NFO13762
 Reviewed By: *[Signature]*
 Date Reviewed: 6/24/17

HARDWARE SCHEDULE

1.	KWIKSET SERIES 400 GRADE 3 CYLINDRICAL LATCH AND SERIES 980 GRADE 1 DEADLOCK HARDWARE TO BE INSTALLED AT 5-1/2" CENTERLINE.
2.	4" X 4" FULL MORTISE BUTT HINGES.

ATTACHMENT DETAIL

- ANCHOR ANALYSIS FOR LOADING CONDITIONS PREPARED, SIGNED AND SEALED BY ROBERTO LOMAS, PE (FLORIDA #62514) WITH THE LOWEST (LEAST) FASTENER RATING FROM THE DIFFERENT FASTENERS BEING CONSIDERED FOR USE. JAMB, HEAD, AND THRESHOLD FASTENERS ANALYZED FOR THIS UNIT INCLUDE #10 WOOD SCREWS OR 1/4" TAPCONS. A PHYSICAL SHIM MUST BE PLACED IN SHIM SPACE AT EACH ANCHOR LOCATION. TAPCON EDGE DISTANCE MIN 2-1/2". WOOD SCREW EDGE DISTANCE MIN 3/4".
- THE WOOD SCREW SINGLE SHEAR DESIGN VALUES COME FROM ANSI/AF&PA NDA FOR SOUTHERN PINE LUMBER AND ACHIEVEMENT OF 1-1/2" MINIMUM EMBEDMENT. THE TAPCON MUST ACHIEVE MINIMUM EMBEDMENT OF 1-1/4".
- WOOD BUCKS BY OTHERS MUST BE ANCHORED PROPERLY TO TRANSFER LOADS TO STRUCTURE.
- MINIMUM DESIGN VALUE STRENGTH OF ANCHORS 155 LBS.

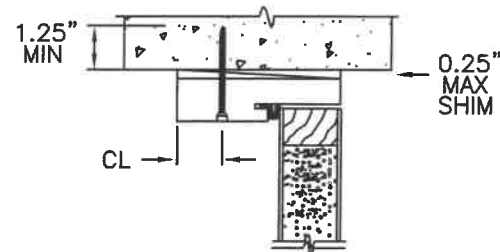

TYPICAL MASONRY ANCHOR INSTALLATION

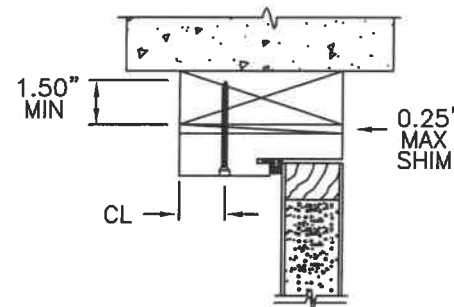

TYPICAL WOOD BUCK ANCHOR INSTALLATION

1"X1/2" CORRUGATED
 3" FROM EACH END
 AND 7" OC

#10X2" WOOD SCREW
 6" FROM EACH END
 AND 12" OC

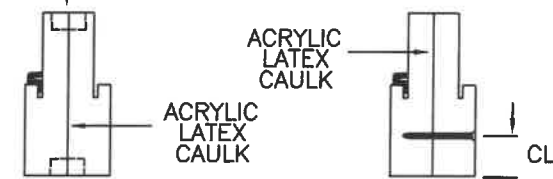

COMBINATION WOOD MULLION (BOXED) COMBINATION WOOD MULLION (BOXED)

(3) #10X2-1/2"
 WOOD SCREWS
 EACH END



INTEGRAL WOOD MULLION (CHS)

MASONITE INTERNATIONAL CORP.
 1955 POWIS ROAD
 WEST CHICAGO, IL 60185

PRODUCT: EXTERIOR DOOR PRODUCT
 6'-8" STEEL-EDGE STEEL GLAZED
 DOUBLE DOOR UNIT

PART OR ASSEMBLY:
 ANCHORING LOCATIONS
 & DETAILS

NO.	DATE	REVISIONS	BY

DATE: 6/21/17
 SCALE: N.T.S.
 DWG. BY: SWS
 CHK. BY:
 DRAWING NO.:
 DWG-MA-FL0223-17
 SHEET 3 OF 3