



**STEEL-EDGE STEEL DOOR UNIT**  
**8'-0" DOUBLE DOOR WITH / WITHOUT SIDELITES**

GENERAL NOTES

- EVALUATED FOR USE IN LOCATIONS ADHERING TO THE FLORIDA BUILDING CODE AND WHERE PRESSURE REQUIREMENTS AS DETERMINED BY ASCE 7, MINIMUM DESIGN LOADS FOR BUILDINGS AND OTHER STRUCTURES, DOES NOT EXCEED THE DESIGN PRESSURES LISTED.
- HURRICANE PROTECTIVE SYSTEM (SHUTTERS) IS NOT REQUIRED ON OPAQUE PANELS, BUT IS REQUIRED ON GLAZED SIDELITES.
- WHEN INSTALLED IN THE WIND-BORNE DEBRIS REGION, EXCLUDING THE HIGH VELOCITY HURRICANE ZONE (HVHZ), HURRICANE PROTECTIVE SYSTEM IS NOT REQUIRED ON OPAQUE PANELS OR PANELS WITH IMPACT GLASS, BUT IS REQUIRED ON PANELS WITH NON-IMPACT GLASS.
- POLYURETHANE CORE FLAME SPREAD INDEX OF 50 AND SMOKE DEVELOPED INDEX OF 60 PER ASTM E84.

5. PLASTICS TESTING:

TEST DESCRIPTION	DESIGNATION	LITE FRAME
SELF IGNITION TEMP	ASTM D1929	842 °F > 650 °F
RATE OF BURNING	ASTM D635	1.28 IN/MIN
SMOKE DENSITY	ASTM D2843	70.2%
TENSILE STRENGTH*	ASTM D638	1.8% DIFF

\* COMPARATIVE TENSILE STRENGTH AFTER WEATHERING  
 4500 HOURS XENON ARC METHOD 1

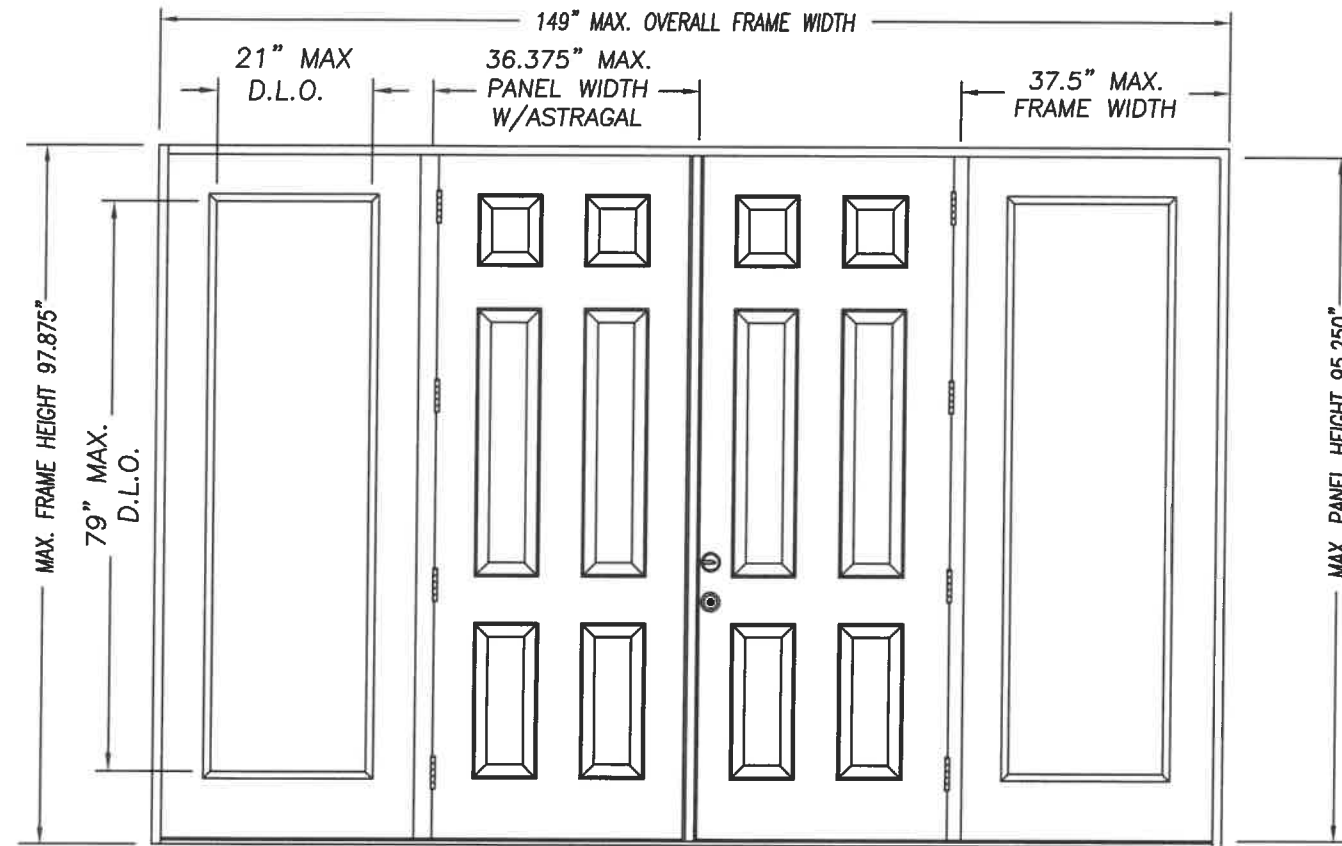

DOUBLE DOOR UNIT W/SIDELITES

Addendum to NAMI

Certification No.: NE013762  
 Reviewed By: [Signature]  
 Date Reviewed: 6/26/17

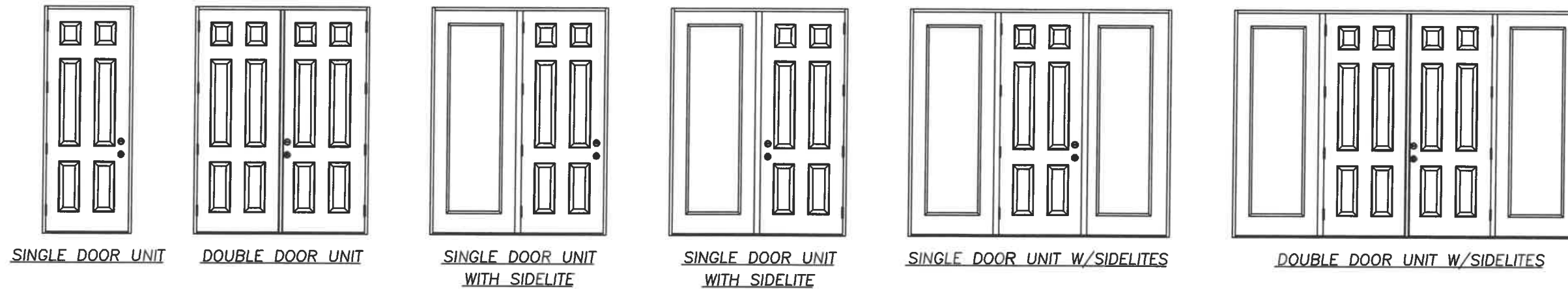

SINGLE DOOR UNIT

DOUBLE DOOR UNIT

SINGLE DOOR UNIT WITH SIDELITE

SINGLE DOOR UNIT WITH SIDELITE

SINGLE DOOR UNIT W/SIDELITES

DOUBLE DOOR UNIT W/SIDELITES

TABLE OF CONTENTS	
SHEET #	DESCRIPTION
1	TYPICAL ELEVATIONS & GENERAL NOTES
2	ANCHORING LOCATIONS & DETAILS
3	ANCHORING LOCATIONS & DETAILS

CONFIG	MAX WIDTH	DESIGN PRESSURE RATING		WHERE WATER INFILTRATION PERFORMANCE IS REQUIRED TO BE 15% OF DESIGN PRESSURE				
		INSWING	OUTSWING	INSWING	BUMPER O/S	Z-SERIES O/S	HIGH DAM O/S	
X	37.5"	+48.0 / -48.0	+48.0 / -48.0	N/A	+25.0 / -25.0	+40.0 / -40.0	+48.0 / -48.0	
XX	74"	+48.0 / -48.0	+48.0 / -48.0	N/A	+25.0 / -25.0	+40.0 / -40.0	+48.0 / -48.0	
OX or XO	75"	+48.0 / -48.0	+48.0 / -48.0	N/A	+25.0 / -25.0	+40.0 / -40.0	+48.0 / -48.0	
OXO	112.5"	+48.0 / -48.0	+48.0 / -48.0	N/A	+25.0 / -25.0	+40.0 / -40.0	+48.0 / -48.0	
OXXO	149"	+48.0 / -48.0	+48.0 / -48.0	N/A	+25.0 / -25.0	+40.0 / -40.0	+48.0 / -48.0	

*Kurt Balthazor*

KURT BALTHAZOR  
 FLORIDA P.E.  
 #56533

**MASONITE INTERNATIONAL CORP.**  
 1955 POWIS ROAD  
 WEST CHICAGO, IL 60185

PRODUCT: EXTERIOR DOOR PRODUCT\*  
 DOUBLE 8'-0" OPAQUE  
 STEEL-EDGE STEEL DOOR

PART OR ASSEMBLY:  
 TYPICAL ELEVATIONS  
 & GENERAL NOTES

NO.	DATE	BY	REVISIONS

DATE: 6/21/17  
 SCALE: N.T.S.  
 DWG. BY: SWS  
 CHK. BY:  
 DRAWING NO.:  
 DWG-MA-FLO224-17  
 SHEET 1 OF 3

MASONITE INTERNATIONAL CORP.  
 1955 POWIS ROAD  
 WEST CHICAGO, IL 60185

PRODUCT:  
 "EXTERIOR DOOR PRODUCT"  
 8'0" STEEL-EDGE STEEL OPAQUE  
 DOUBLE DOOR UNIT

PART OR ASSEMBLY:  
 ANCHORING LOCATIONS  
 & DETAILS

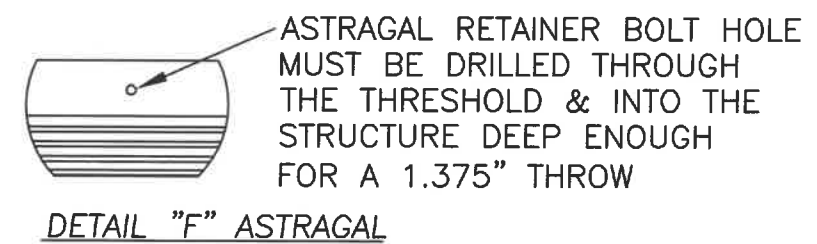
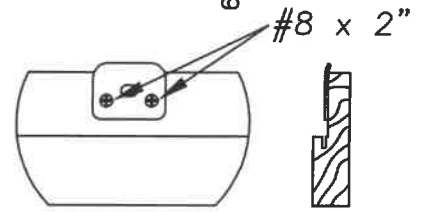
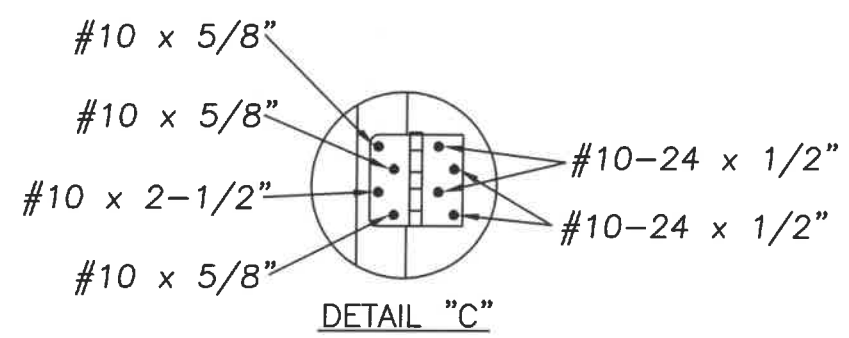
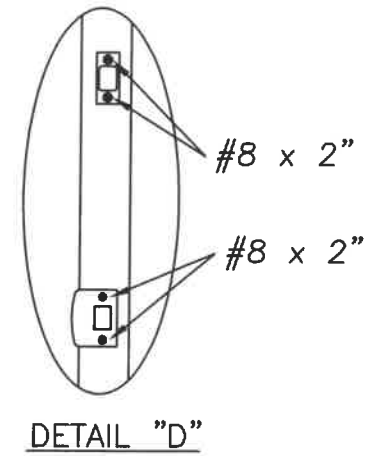
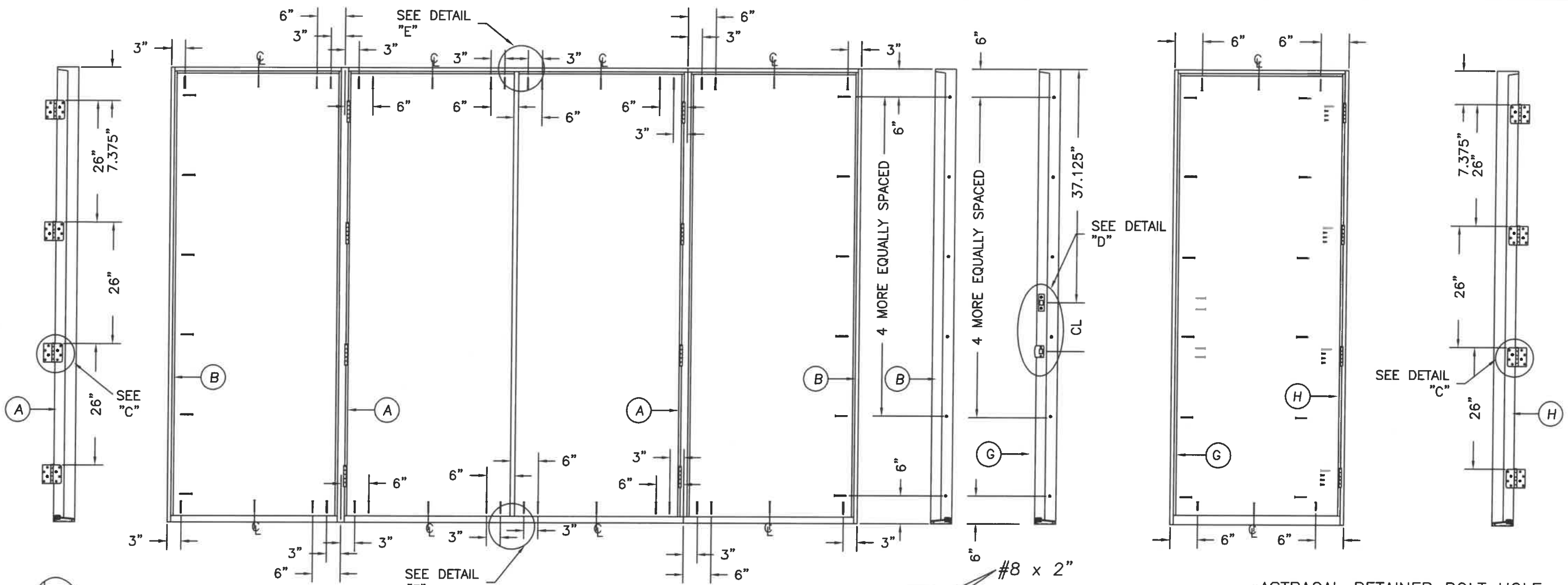

ATTACH ASTRAGAL RETAINER BOLT STRIKE PLATE TO FRAME AS SHOWN.

ASTRAGAL RETAINER BOLT HOLE MUST BE DRILLED THROUGH THE THRESHOLD & INTO THE STRUCTURE DEEP ENOUGH FOR A 1.375" THROW

Addendum to NAMI

Certification No.: N3013762  
 Reviewed By: [Signature]  
 Date Reviewed: 10/25/17

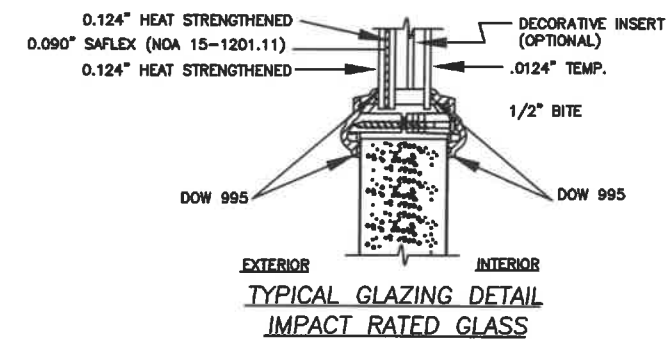
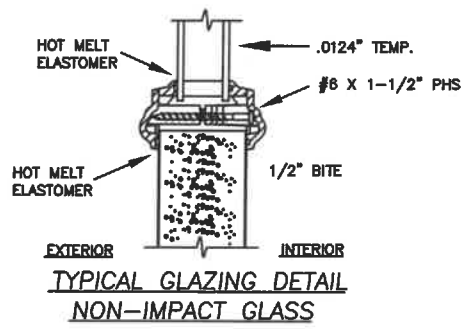
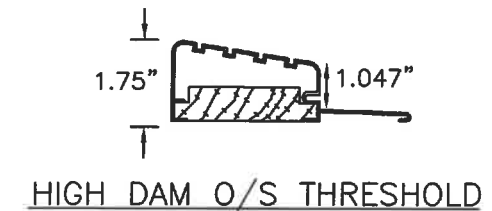
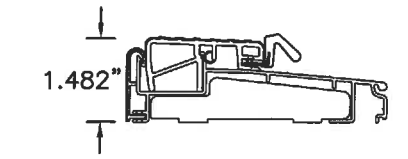
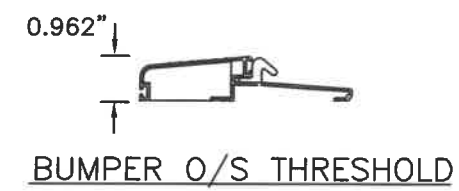
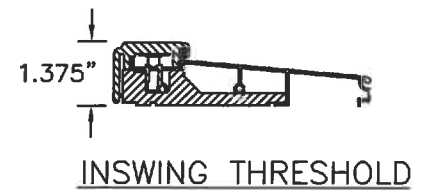

NO.	DATE	CORRECTED GLAZING	SWS	BY
A	10/23/17			

DATE: 6/21/17  
 SCALE: N.T.S.  
 DWG. BY: SWS  
 CHK. BY:  
 DRAWING NO.:  
 DWG-MA-FL0224-17  
 SHEET 2 OF 3

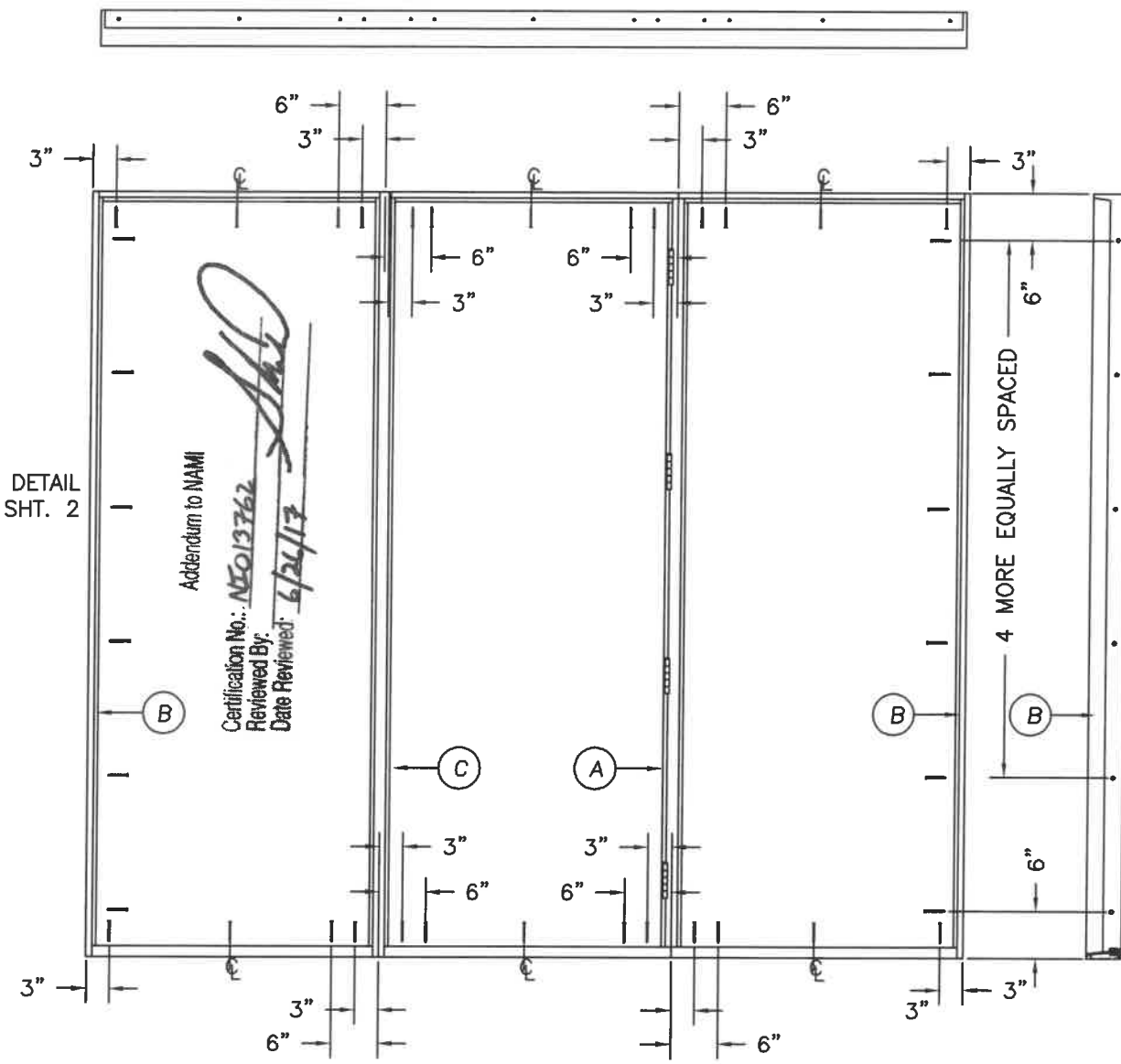
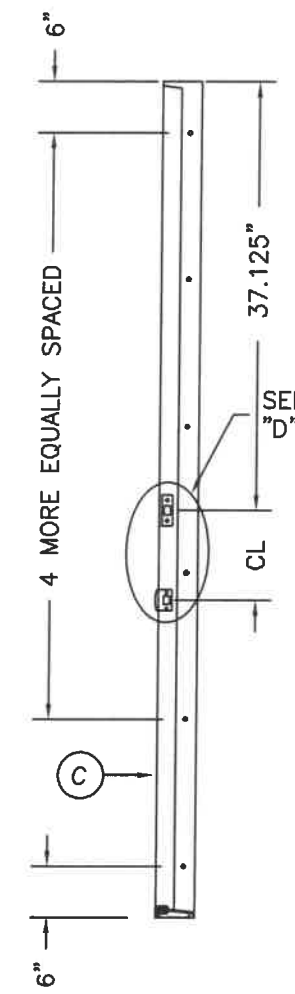
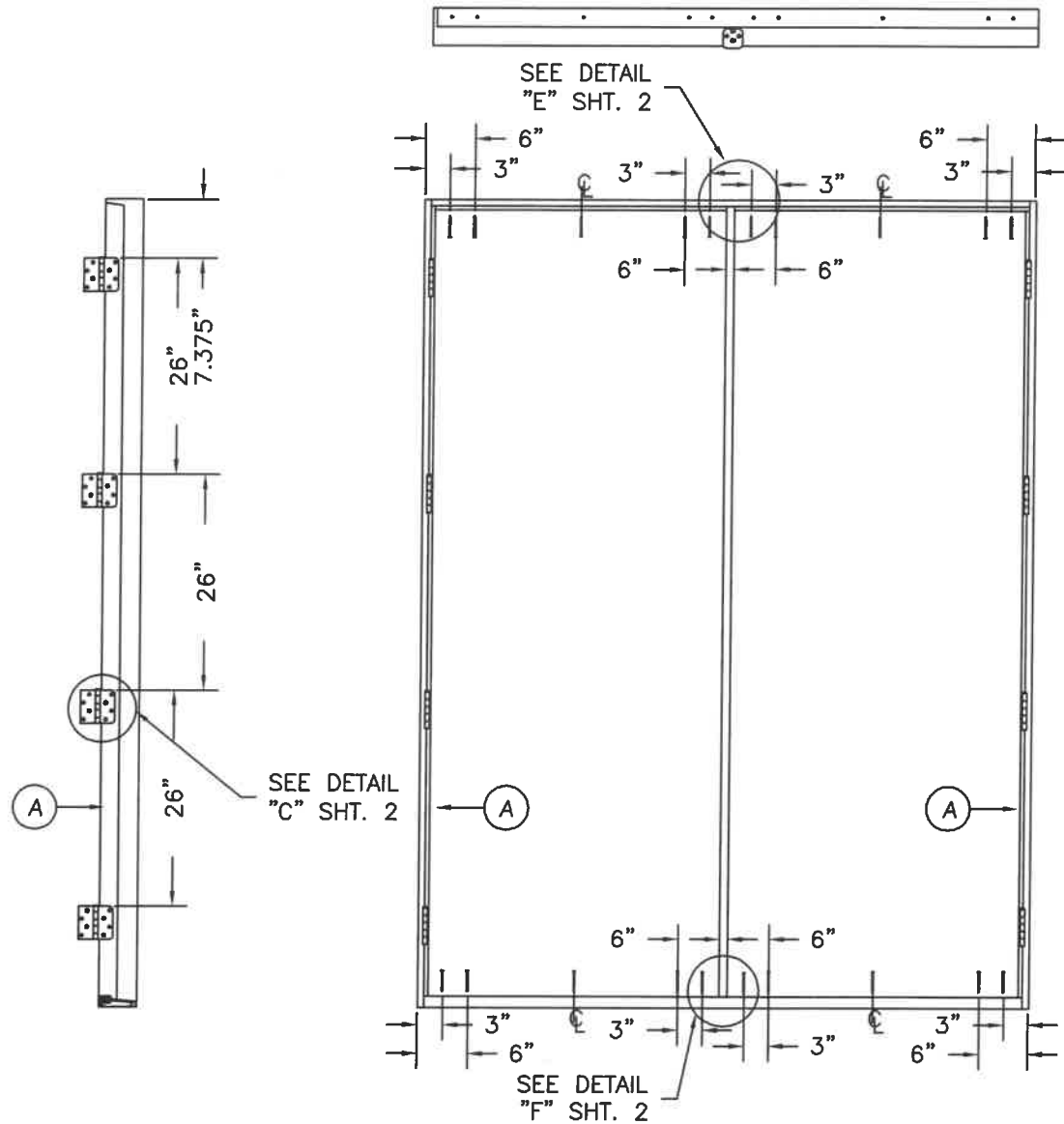

**ATTACHMENT DETAIL**

1. ANCHOR ANALYSIS FOR LOADING CONDITIONS PREPARED, SIGNED AND SEALED BY LUIS R. LOMAS, PE (FLORIDA #62514) WITH THE LOWEST (LEAST) FASTENER RATING FROM THE DIFFERENT FASTENERS BEING CONSIDERED FOR USE. JAMB, HEAD, AND THRESHOLD FASTENERS ANALYZED FOR THIS UNIT INCLUDE #10 WOOD SCREWS OR 1/4" TAPCONS. A PHYSICAL SHIM MUST BE PLACED IN SHIM SPACE AT EACH ANCHOR LOCATION. TAPCON EDGE DISTANCE MIN 2-1/2". WOOD SCREW EDGE DISTANCE MIN 3/4".
2. THE WOOD SCREW SINGLE SHEAR DESIGN VALUES COME FROM ANSI/AF&PA NDA FOR SOUTHERN PINE LUMBER AND ACHIEVEMENT OF 1-1/2" MINIMUM EMBEDMENT. THE TAPCON MUST ACHIEVE MINIMUM EMBEDMENT OF 1-1/4".
3. WOOD BUCKS BY OTHERS MUST BE ANCHORED PROPERLY TO TRANSFER LOADS TO STRUCTURE.
4. MINIMUM DESIGN VALUE STRENGTH OF ANCHORS 155 LBS.

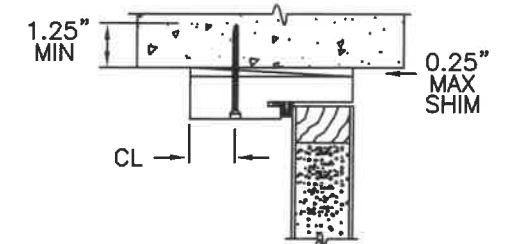

TYPICAL MASONRY ANCHOR INSTALLATION

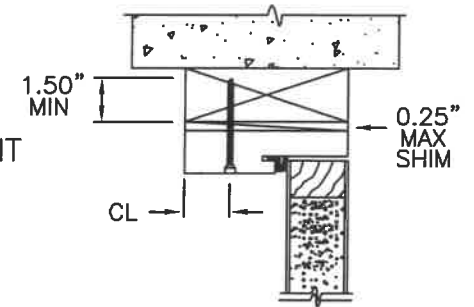

TYPICAL WOOD BUCK ANCHOR INSTALLATION

**HARDWARE SCHEDULE**

1. KWIKSET SERIES 400 GRADE 3 CYLINDRICAL LATCH AND SERIES 980 GRADE 1 DEADLOCK HARDWARE TO BE INSTALLED AT 10-1/2" CENTERLINE.
2. 4" X 4" FULL MORTISE BUTT HINGES.

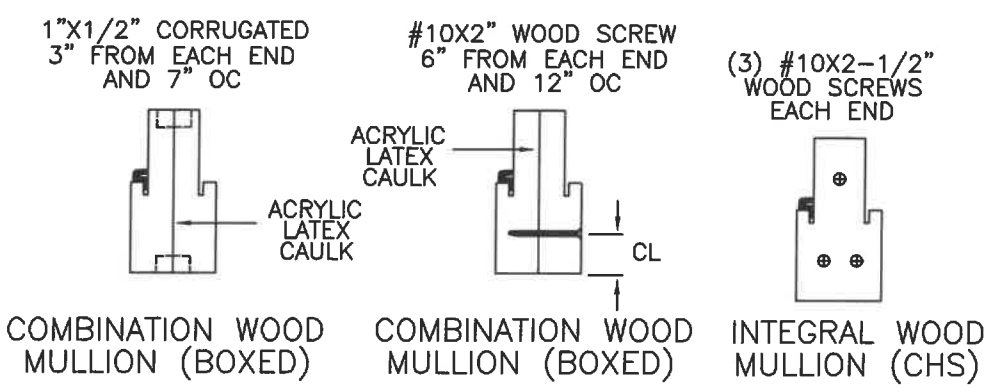

Addendum to NAMI  
 Certification No.: N1013762  
 Reviewed By: [Signature]  
 Date Reviewed: 6/24/17

**MASONITE INTERNATIONAL CORP.**  
 1955 POWIS RD.  
 WEST CHICAGO, IL 60185

PRODUCT: "EXTERIOR DOOR PRODUCT"  
 8'0" STEEL-EDGE STEEL OPAQUE  
 DOUBLE DOOR UNIT

PART OR ASSEMBLY:  
 ANCHORING LOCATIONS  
 & DETAILS

NO.	DATE	BY	REVISIONS

DATE: 6/21/17  
 SCALE: N.T.S.  
 DWG. BY: SWS  
 CHK. BY:  
 DRAWING NO.:  
 DWG-MA-FLO224-17  
 SHEET 3 OF 3