

Maximum Door Width	Center Hinges per Section	Design Loads
6'-0"	1	51.0 -57.7
8'-0"	1	
9'-0"	1	30.6 -34.6
10'-0"	1	
12'-0"	2	41.5 -46.9
16'-0"	3	32.7 -36.5
18'-0"	3	26.4 -29.4



Scott A. Brown, P.E. Lic. No. 65940
Wendler Engineering Services, Inc.
698 Timber Creek Road, Dixon, IL 61021
FBPE CA Lic. No. 31544
Structural Adequacy for Wind Load

Printed copies of this document are not considered signed and sealed and the SHA authentication code must be verified on any electronic copies.

Scale: None		Title: Spec, Wind Load RockCreeke	
Drawn by: R. Frey		 1101 East River Road Dixon, IL 61021	
Checked by: G. Wedekind			
Date: 04/27/21		No. P-3351	
Rev. A		Sheet 1 of 3	
Description: New release for production.		Rev. A	
ECO: 8284.01	ECO: 8284.01	ECO: 8284.01	ECO: 8284.01

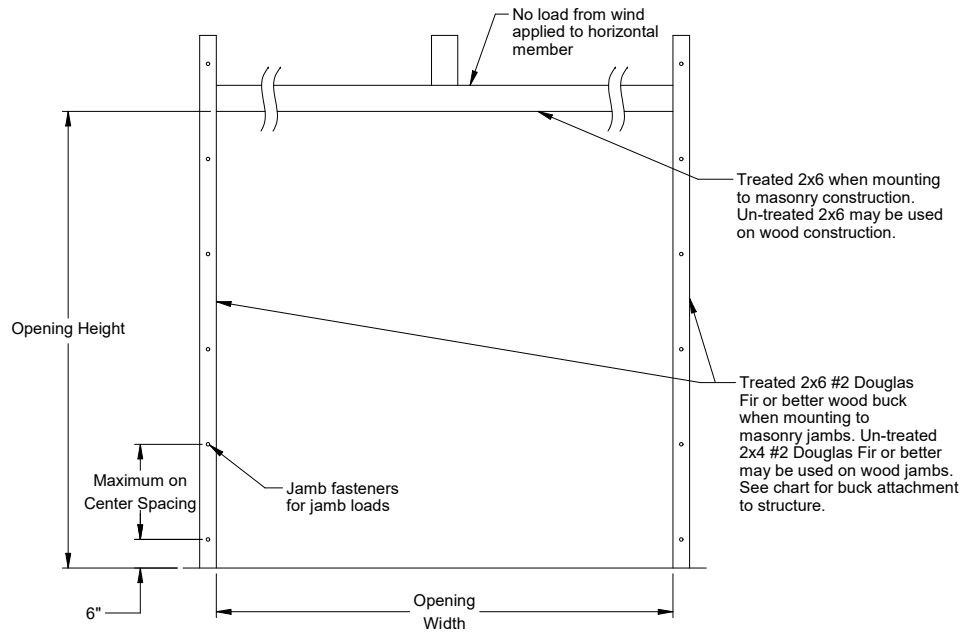
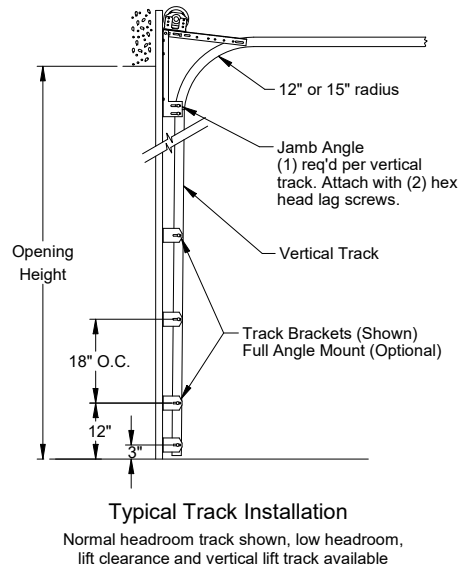

Jamb Attachment Notes:

1. Maximum Positive Load per Jamb = $(16'-0" \times 32.7 \text{ PSF}) / 2 = 262 \text{ lbs. per foot.}$
2. Maximum Negative Load per Jamb = $(16'-0" \times -36.5 \text{ PSF}) / 2 = 292 \text{ lbs. per foot.}$
3. Design of the supporting structure shall be the sole responsibility of the building designer and shall be designed for the jamb loads listed in notes 1 and 2.
4. Alternate jamb attachments may be used if approved by a registered Professional Engineer.
5. DASMA Technical Data Sheet TDS-161 may be used for alternate jamb attachments.
6. 3/8" diameter lag screws required 1/16" pilot hole and 1-1/2" minimum required distance.

1-Pane window style shown. Other window styles available.

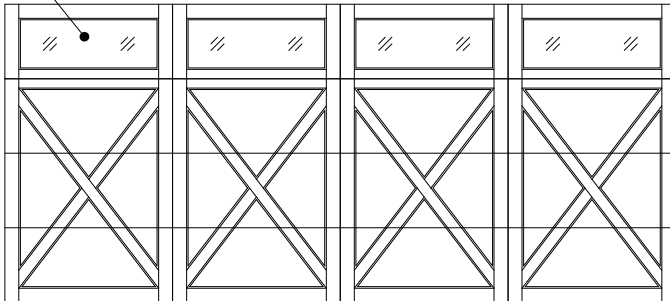

Exterior Elevation

Flush section with decorative trim boards. Arrangement of boards will vary based on design, cross bucks shown.

2x6 Attachment to Structure

Structure Type	Fastener Type	Minimum Embedment	Minimum Edge Distance	Minimum on Center Spacing	Maximum on Center Spacing	Allowable Tension Load
2500 PSI Min. Concrete	1/4" Tapcon+ (Plus) with 1-1/8" OD Washer	2"	2.5	6"	24"	526
Southern Pine	3/8" x 3" Lag with 1-1/8" OD Washer	1.50"	1.50"	1.50"	24"	655
Spruce Pine Fir	3/8" x 3" LAG with 1-1/8" OD Washer	1.50"	1.50"	1.50"	22"	482



Scott A. Brown, P.E. Lic. No. 65940
Wendler Engineering Services, Inc.
698 Timber Creek Road, Dixon, IL 61021
FBPE CA Lic. No. 31544
Structural Adequacy for Wind Load

Scale: None	 1101 East River Road Dixon, IL 61021	Title: Spec, Wind Load RockCreeke	
Drawn by: R. Frey		No. P-3351	Sheet 2
Checked by: G. Wedekind			Rev A
Date: 04/27/21 ECO: 8284.01			

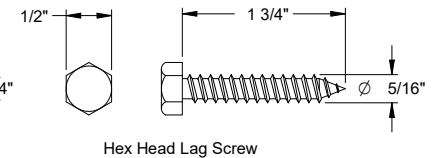
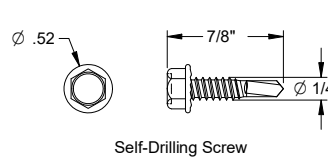
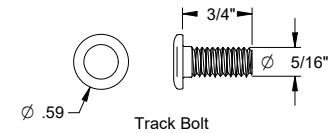
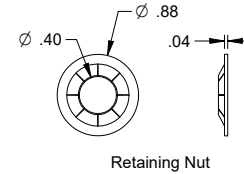
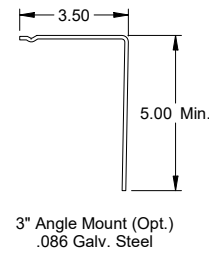
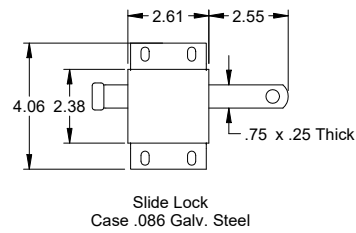
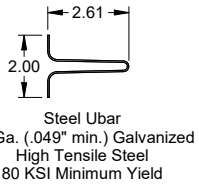
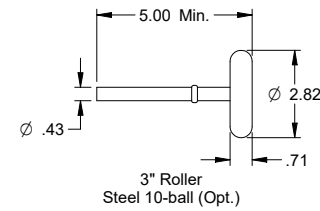
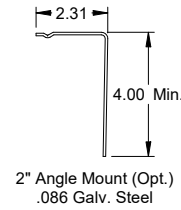
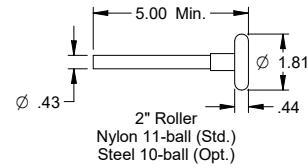
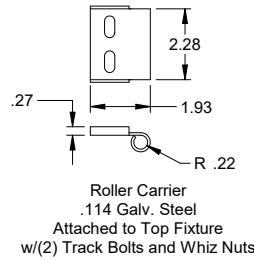
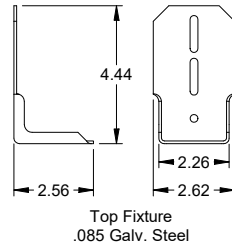
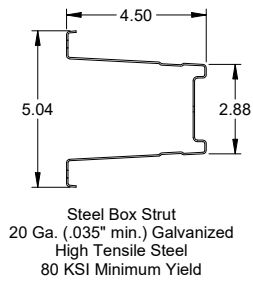
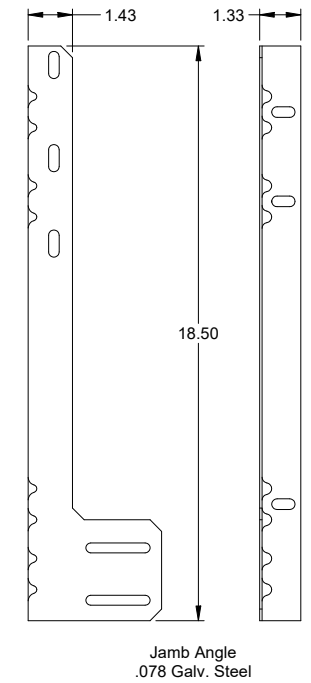
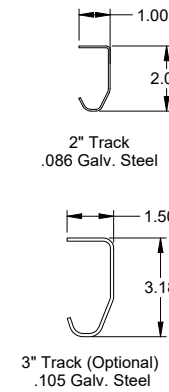
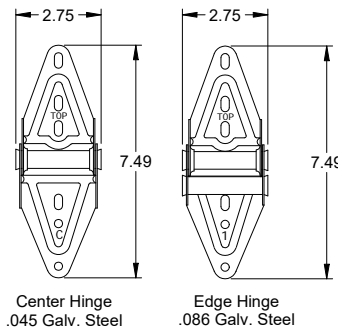
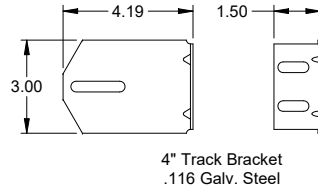
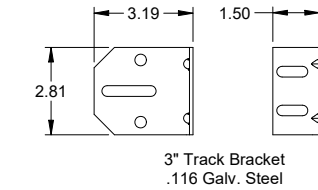
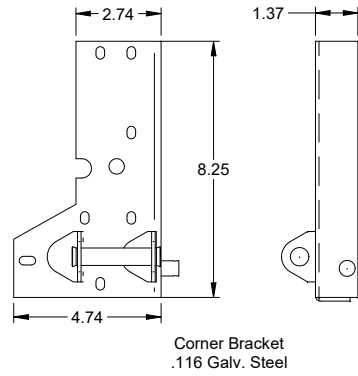

Scott A. Brown, P.E. Lic. No. 65940
Wendler Engineering Services, Inc.
698 Timber Creek Road, Dixon, IL 61021
FBPE CA Lic. No. 31544
Structural Adequacy for Wind Load

Printed copies of this document are not considered signed and sealed and the SHIA authentication code must be verified on any electronic copies.

Scale: None
Drawn by: R. Frey
Checked by: G. Wedekind
Date: 04/27/21
ECO: 8284.01



Title: Spec, Wind Load
RockCreeke

No. P-3351	Sheet 3	Rev A
------------	---------	-------