

DOOR DESIGN LOAD CAPACITY - PSF					
AVERAGE PANEL WIDTH INCHES	DOOR FRAME HEIGHT INCHES	GLASS TYPES 'C', 'C1', 'D' & 'D1'			
		STD. ASTRAGAL		REINF. ASTRAGAL	
		EXT.(+)	INT.(-)	EXT.(+)	INT.(-)
30	82-7/8	80.0	100.0	80.0	100.0
36		80.0	100.0	80.0	100.0
42		80.0	100.0	80.0	100.0
48		80.0	100.0	80.0	100.0
54		71.1	88.9	80.0	88.9
60		64.0	80.0	64.0	80.0
30	84	80.0	100.0	80.0	100.0
36		80.0	100.0	80.0	100.0
42		80.0	100.0	80.0	100.0
48		80.0	100.0	80.0	100.0
54		71.1	88.9	71.1	88.9
60		64.0	80.0	64.0	80.0
30	90	80.0	100.0	80.0	100.0
36		80.0	100.0	80.0	100.0
42		80.0	100.0	80.0	100.0
48		80.0	100.0	80.0	100.0
54		71.1	88.9	71.1	88.9
60		-	-	64.0	80.0
30	96	80.0	100.0	80.0	100.0
36		80.0	100.0	80.0	100.0
42		80.0	100.0	80.0	100.0
48		80.0	100.0	80.0	100.0
54		71.1	88.9	71.1	88.9
60		-	-	64.0	80.0
30	102	80.0	100.0	80.0	100.0
36		80.0	100.0	80.0	100.0
42		80.0	100.0	80.0	100.0
48		80.0	100.0	80.0	100.0
50		-	-	76.8	96.0
52		-	-	73.8	92.3
54		-	-	71.1	88.9
56		-	-	68.6	85.7
30	108	80.0	100.0	80.0	100.0
36		80.0	100.0	80.0	100.0
42		80.0	100.0	80.0	100.0
48		80.0	100.0	80.0	100.0
50		-	-	76.8	96.0
52		-	-	73.8	92.3
30	114	-	-	80.0	100.0
36		-	-	80.0	100.0
42		-	-	80.0	100.0
48		-	-	80.0	100.0
50		-	-	76.8	96.0
30	120	-	-	80.0	100.0
36		-	-	80.0	100.0
42		-	-	80.0	100.0
48		-	-	80.0	100.0

ANCHOR LOAD CAPACITY - PSF				
ANCHOR TYPE		ANCHORS 'A', 'B', 'C' & 'D'		
PANEL WIDTH INCHES	DOOR FRAME HEIGHT INCHES	3/8" SHIM		1/2" MAX. SHIM
		6 ANCHORS AT MTG. STILE ENDS	6 ANCHORS AT MTG. STILE ENDS	8 ANCHORS AT MTG. STILE ENDS
		EXT. (+) INT. (-)	EXT. (+) INT. (-)	EXT. (+) INT. (-)
30	82-7/8	100.0	100.0	100.0
36		100.0	100.0	100.0
42		100.0	100.0	100.0
48		100.0	100.0	100.0
54		100.0	100.0	100.0
60		100.0	100.0	100.0
30	84	100.0	100.0	100.0
36		100.0	100.0	100.0
42		100.0	100.0	100.0
48		100.0	100.0	100.0
54		100.0	100.0	100.0
60		100.0	100.0	100.0
30	90	100.0	100.0	100.0
36		100.0	100.0	100.0
42		100.0	100.0	100.0
48		100.0	100.0	100.0
54		100.0	100.0	100.0
60		100.0	100.0	100.0
30	96	100.0	100.0	100.0
36		100.0	100.0	100.0
42		100.0	100.0	100.0
48		100.0	100.0	100.0
54		100.0	98.7	100.0
60		100.0	88.8	100.0
30	102	100.0	100.0	100.0
36		100.0	100.0	100.0
42		100.0	100.0	100.0
48		100.0	100.0	100.0
50		100.0	100.0	100.0
52		100.0	96.4	100.0
54		100.0	92.9	100.0
56		100.0	89.5	100.0
30	108	100.0	100.0	100.0
36		100.0	100.0	100.0
42		100.0	100.0	100.0
48		100.0	98.7	100.0
50		100.0	94.7	100.0
52		100.0	91.1	100.0
30	114	100.0	100.0	100.0
36		100.0	100.0	100.0
42		100.0	100.0	100.0
48		100.0	93.5	100.0
50		100.0	89.7	100.0
30	120	100.0	100.0	100.0
36		100.0	100.0	100.0
42		100.0	100.0	100.0
48		100.0	88.8	100.0

NOTE:
GLASS CAPACITIES ON THIS SHEET ARE
BASED ON ASTM E1300-09 (3 SEC. GUSTS)
AND FLORIDA BUILDING COMMISSION
DECLARATORY STATEMENT DCA05-DEC-219

INSTRUCTIONS:

USE CHARTS AS FOLLOWS.

- STEP 1** DETERMINE DESIGN WIND LOAD REQUIREMENT BASED ON WIND VELOCITY, BLDG. HEIGHT, WIND ZONE USING APPLICABLE ASCE 7 STANDARD.
- STEP 2** DETERMINE DOOR CAPACITY FROM TABLE ON SHEET 1 FOR THE GLASS TYPE USED.
- STEP 3** USING CHARTS ON SHEET 1 SELECT ANCHOR OPTION WITH DESIGN RATING MORE THAN DESIGN LOAD SPECIFIED IN STEP 1 ABOVE.
- STEP 4** THE LOWEST VALUE RESULTING FROM STEPS 2 AND 3 SHALL APPLY TO ENTIRE SYSTEM.
- STEP 5** SEE SHEET 8 TO DETERMINE MIN. AND MAX. GAP DIMENSIONS FOR UNANCHORED JAMBS.

THESE DOORS ARE RATED FOR SMALL MISSILE IMPACT.
F.B.C. APPROVED IMPACT RESISTANT SHUTTERS REQUIRED FOR INSTALLATIONS UP TO 30 FT. OF GRADE.
SHUTTERS NOT REQD. FOR INSTALLATIONS ABOVE 30 FT. OF GRADE.

**SERIES 1100 (S.M.I.)
ALUMINUM SLIDING GLASS DOOR**

THIS PRODUCT HAS BEEN DESIGNED AND TESTED TO COMPLY WITH THE REQUIREMENTS OF THE 2017 (6TH EDITION)/2020 (7TH EDITION) FLORIDA BUILDING CODE INCLUDING HIGH VELOCITY HURRICANE ZONE (HVHZ).

1BY OR 2BY WOOD BUCKS & BUCK FASTENERS BY OTHERS, MUST BE DESIGNED AND INSTALLED ADEQUATELY TO TRANSFER APPLIED PRODUCT LOADS TO THE BUILDING STRUCTURE.

ANCHORS SHALL BE CORROSION RESISTANT, SPACED AS SHOWN ON DETAILS AND INSTALLED PER MANUF'S INSTRUCTIONS. SPECIFIED EMBEDMENT TO BASE MATERIAL SHALL BE BEYOND WALL DRESSING OR STUCCO.

A LOAD DURATION INCREASE IS USED IN DESIGN OF ANCHORS INTO WOOD ONLY. ALL SHIMS TO BE HIGH IMPACT, NON-METALLIC AND NON-COMPRESSIBLE.

MATERIALS INCLUDING BUT NOT LIMITED TO STEEL/METAL SCREWS, THAT COME INTO CONTACT WITH OTHER DISSIMILAR MATERIALS SHALL MEET THE REQUIREMENTS OF THE 2017/2020 FLORIDA BLDG. CODE & ADOPTED STANDARDS.

THIS PRODUCT APPROVAL IS GENERIC AND DOES NOT PROVIDE INFORMATION FOR A SITE SPECIFIC PROJECT, i.e. LIFE SAFETY OF THIS PRODUCT, ADEQUACY OF STRUCTURE RECEIVING THIS PRODUCT AND SEALING AROUND OPENING FOR WATER INFILTRATION RESISTANCE ETC. CONDITIONS NOT SHOWN IN THIS DRAWING ARE TO BE ANALYZED SEPARATELY, AND TO BE REVIEWED BY BUILDING OFFICIAL.

DESIGN LOADS SHOWN ARE BASED ON 'ALLOWABLE STRESS DESIGN (ASD)'.

MANUFACTURER'S LABEL SHALL BE LOCATED ON A READILY VISIBLE LOCATION IN ACCORDANCE WITH SECTION 1709.9.3 OF FLORIDA BUILDING CODE. LABELING TO COMPLY WITH SECTION 1709.9.2.

Sealed:8/7/2020

FL #25959.2

- A- CONTRACTOR TO BE RESPONSIBLE FOR THE SELECTION, PURCHASE AND INSTALLATION OF THIS PRODUCT BASED ON THIS PRODUCT EVALUATION PROVIDED HE/SHE DOES NOT DEVIATE FROM THE CONDITIONS DETAILED ON THIS DOCUMENT.
- B- THIS PRODUCT EVALUATION DOCUMENT WILL BE CONSIDERED INVALID IF ALTERED BY ANY MEANS.
- C- SITE SPECIFIC PROJECTS SHALL BE PREPARED BY A FLORIDA REGISTERED ENGINEER OR ARCHITECT WHICH WILL BECOME THE ENGINEER OF RECORD (E.O.R.) FOR THE PROJECT AND WHO WILL BE RESPONSIBLE FOR THE PROPER USE OF THE P.E.D. ENGINEER OF RECORD, ACTING AS A DELEGATED ENGINEER TO THE P.E.D. ENGINEER SHALL SUBMIT TO THIS LATTER THE SITE SPECIFIC DRAWINGS FOR REVIEW.
- D- THIS P.E.D. SHALL BEAR THE DATE AND ORIGINAL SEAL AND SIGNATURE OF THE PROFESSIONAL ENGINEER OF RECORD THAT PREPARED IT.

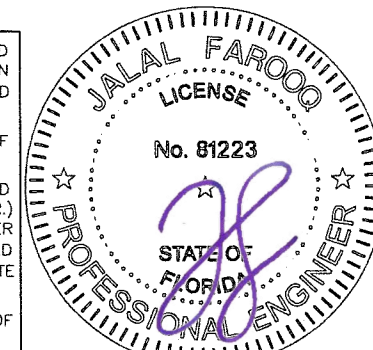

af c
AL-FAROOQ CORPORATION
ENGINEERS & PRODUCT DEVELOPMENT
9360 SUNSET DRIVE, SUITE 220
MIAMI, FLORIDA 33173 (C.A.N. 3538)
TEL (305) 262-6978 FAX (305) 264-8100

SERIES 1100 ALUM SLIDING GLASS DOOR (S.M.I.)
MR-GLASS DOORS & WINDOWS MANUFACTURING, LLC
8051 N.W. 79th Place
Medley, FL. 33166
Tel. (305) 764-3963 Fax. (305) 470-8285

revisions:	no	date	by	description
	A	07-24-20		UPDATED TO 2020 FBC
date:	12-28-17			
scale:	-			
dr. by:	TARIQ			
chk. by:				
drawing no.	18-16F			
sheet	1 of 11			

FOR INSTALLATIONS WHERE WATER INFILTRATION RESISTANCE IS REQUIRED
LIMIT ALL EXTERIOR(+) LOADS TO +76.7 PSF FOR 2-13/16" SILL HEIGHTS
SEE SHEET 5 FOR DETAILS

REINF. ASTRAGAL ONLY IN CONFIGURATIONS THAT REQUIRE ASTRAGAL.

AVERAGE PANEL WIDTH = DOOR FRAME WIDTH
NUMBER OF PANELS

COMP-ANL\18-16F-MG

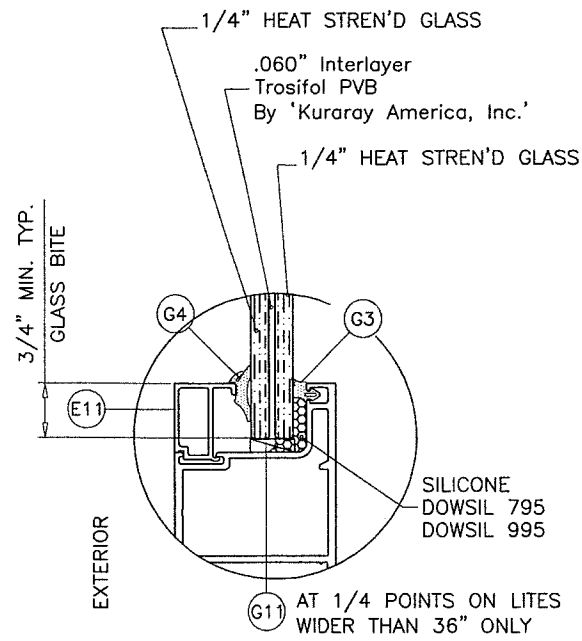

GLASS TYPE 'C'
9/16" OVERALL LAMINATED GLASS

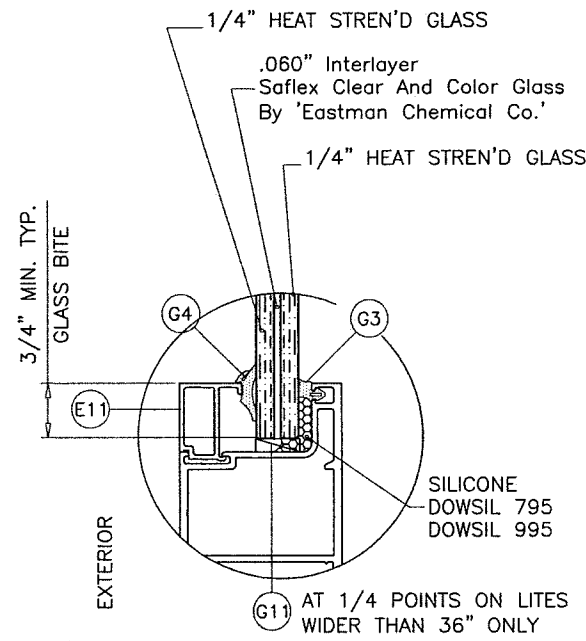

GLASS TYPE 'D'
9/16" OVERALL LAMINATED GLASS

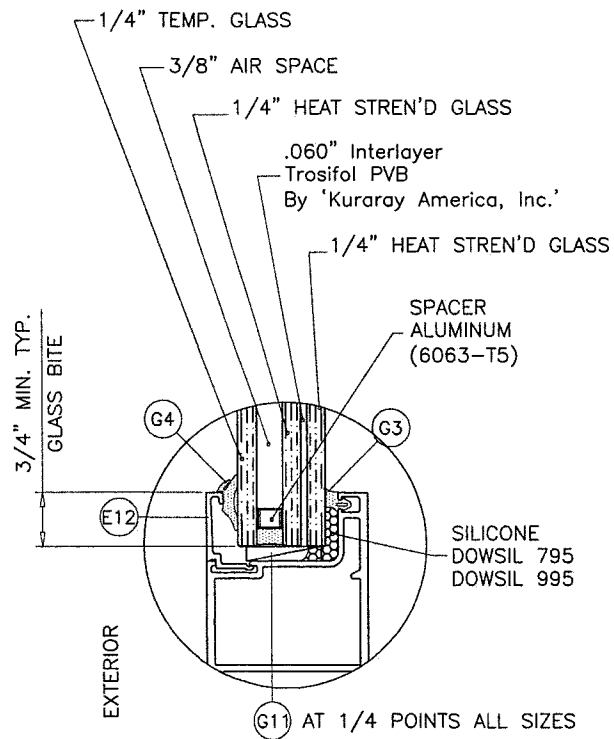

GLASS TYPE 'CI'
1-3/16" OVERALL INSUL. LAM. GLASS

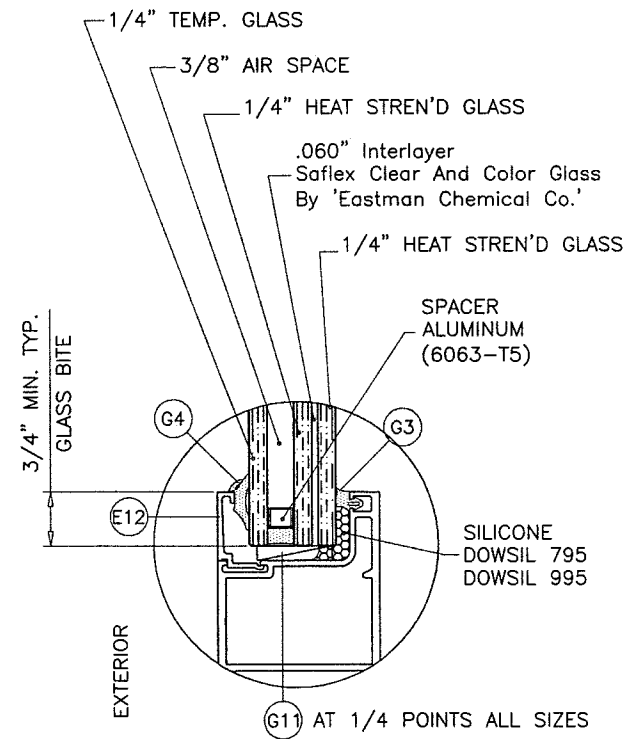

GLASS TYPE 'DI'
1-3/16" OVERALL INSUL. LAM. GLASS

GLAZING OPTIONS

af c
AL-FAROQ CORPORATION
ENGINEERS & PRODUCT DEVELOPMENT
9360 SUNSET DRIVE, SUITE 220
MIAMI, FLORIDA 33173 (C.A.N. 3588)
TEL (305) 264-8100 FAX (305) 262-6978
COMP-ANL 18-16F-MG

SERIES 1100 ALUM SLIDING GLASS DOOR (S.M.I.)
MR-GLASS DOORS & WINDOWS MANUFACTURING, LLC
8051 N.W. 79th Place
Medley, FL. 33166
Tel. (305) 764-3963 Fax. (305) 470-8285

revisions:	no	date	by	description

date: 12-28-17
scale: 3/8" = 1"
dr. by: TARIQ
chk. by:

drawing no.
18-16F
sheet 2 of 11



Sealed:8/7/2020

FL #25959.2

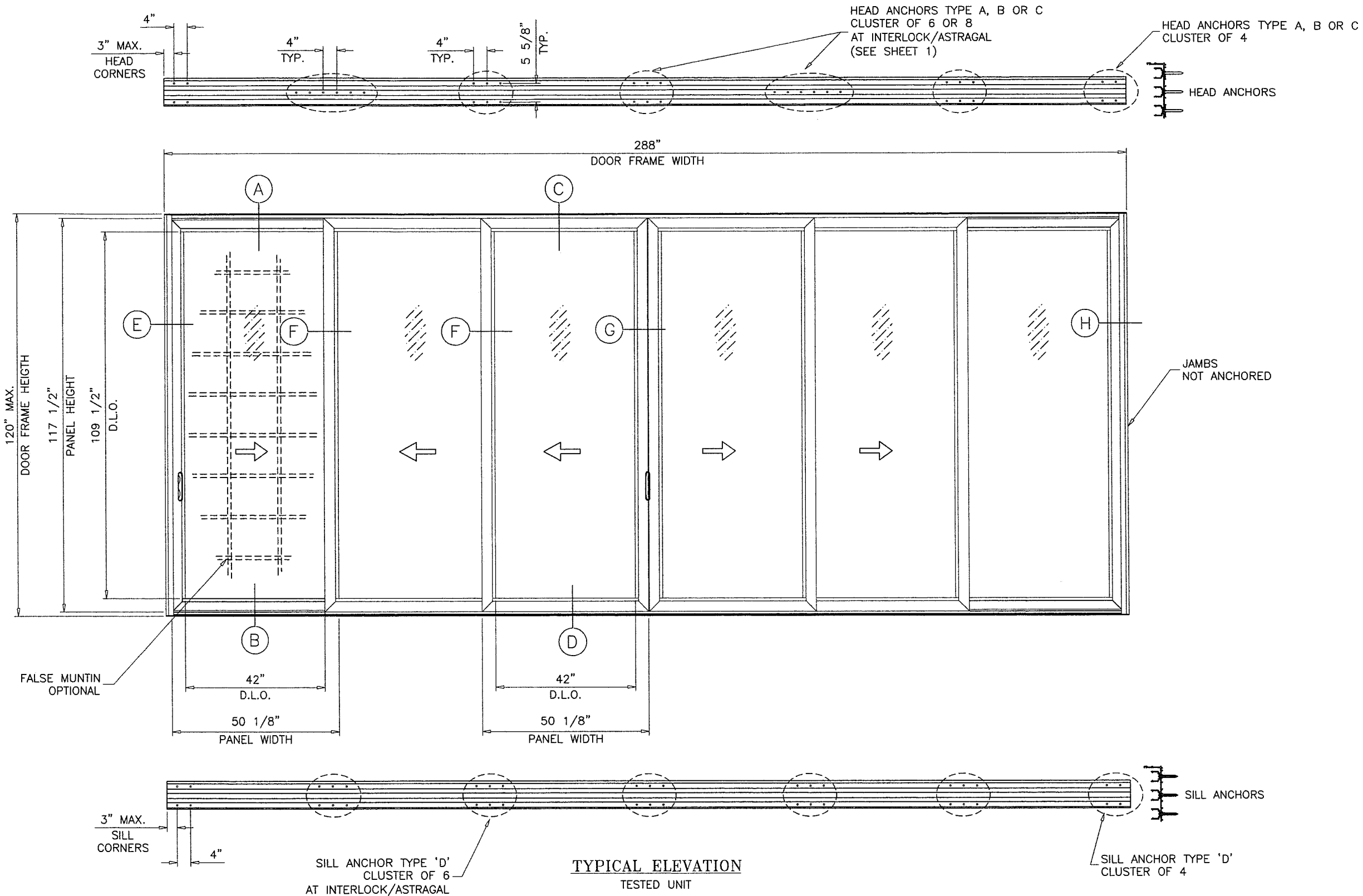

DAYLITE OPENINGS WIDTHS:
PANEL WIDTH - 7.313"

DAYLITE OPENING HEIGHT:
PANEL HEIGHT - 8.0"

PANEL HEIGHT = DOOR FRAME HEIGHT - 2.625"

MAX. FRAME AREA OF S.G.D. SHALL NOT EXCEED FRAME AND PANEL AREA OF TESTED UNIT PER FBC REQUIREMENTS.

Sealed:8/7/2020

FL #25959.2

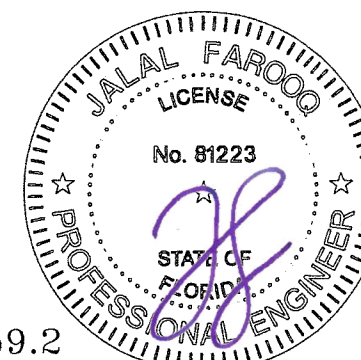

af c

AL-FAROOQ CORPORATION
ENGINEERS & PRODUCT DEVELOPMENT
9360 SUNSET DRIVE, SUITE 220
MIAMI, FLORIDA 33173 (C.A.N. 3538)
TEL (305) 264-8100 FAX (305) 262-6978
COMP-ANL\18-16F-MG

SERIES 1100 ALUM SLIDING GLASS DOOR (S.M.I.)

MR-GLASS DOORS & WINDOWS MANUFACTURING, LLC
8051 N.W. 79th Place
Medley, FL. 33166
Tel. (305) 764-3963 Fax. (305) 470-8285

revisions:	no	date	by	description

date: 12-28-17
scale: 3/8"=1'-0"
dr. by: TARIQ
chk. by:

drawing no.
18-16F

sheet 3 of 11

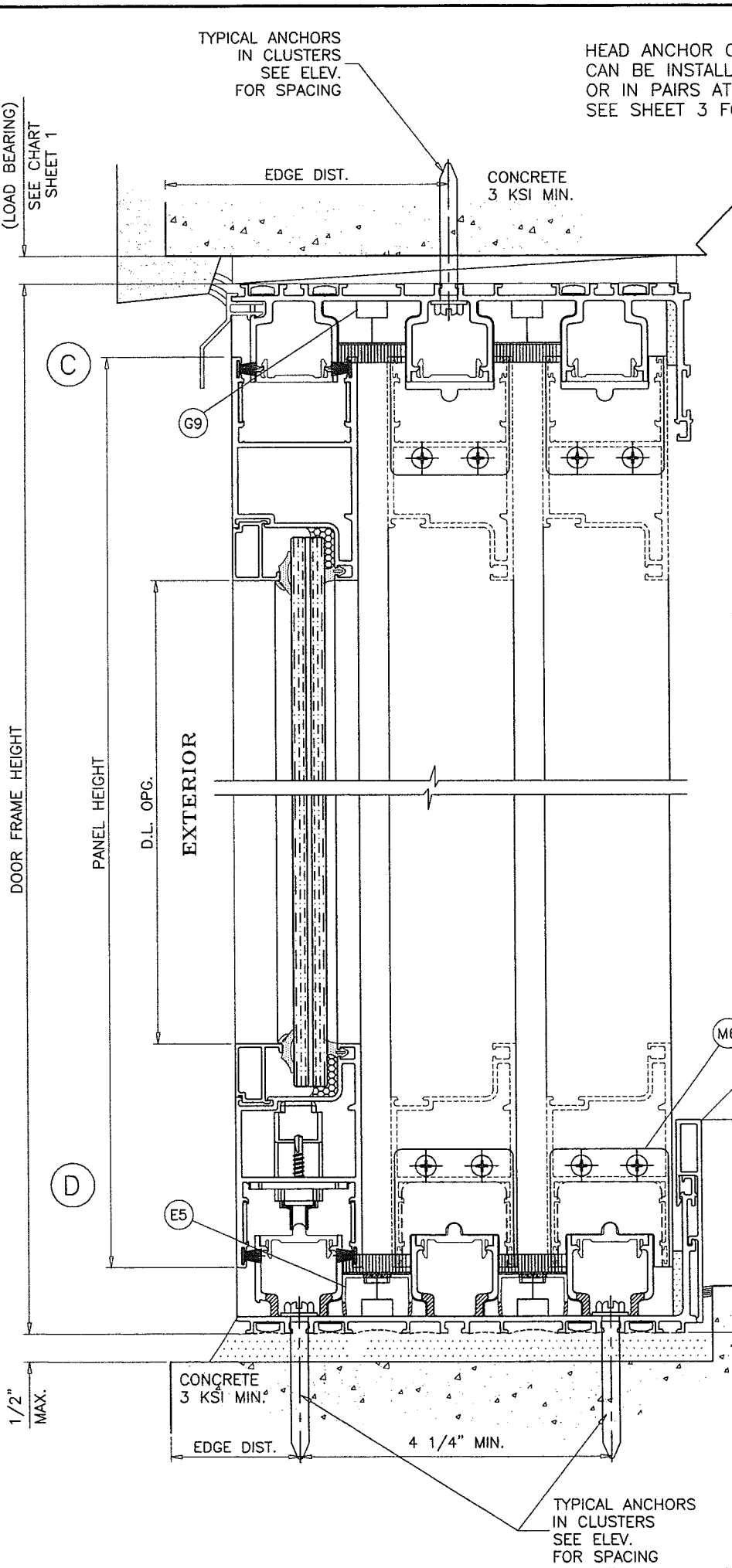
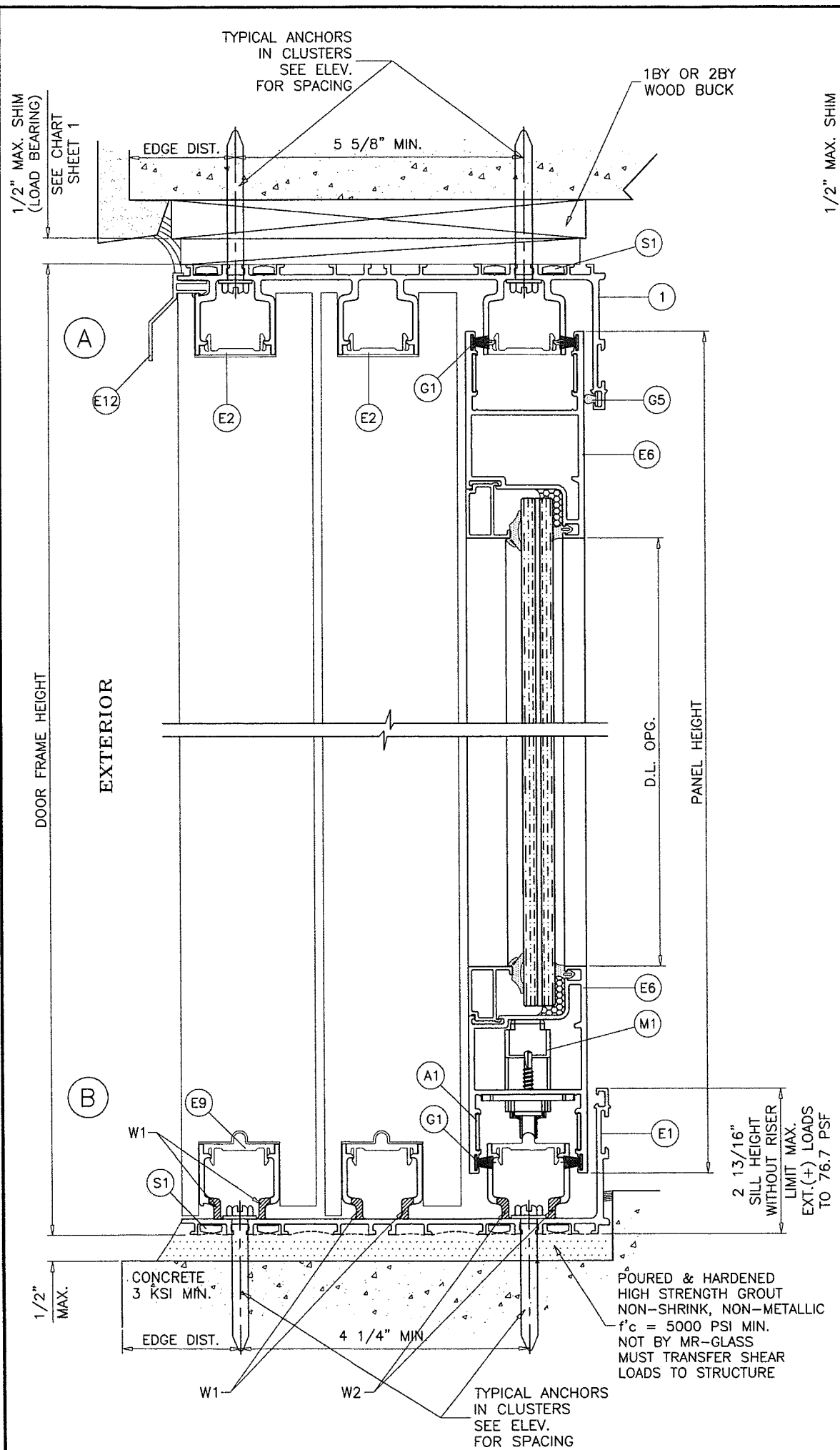

HEAD ANCHOR CLUSTERS AT INTERLOCK AND ASTRAGAL LOCATIONS CAN BE INSTALLED IN LINE AT CENTER TRACK OR IN PAIRS AT EXTERIOR AND INTERIOR TRACKS SEE SHEET 3 FOR SPACING

WEEPHOLES:

- W1 = 1/4" X 1-1/2" LONG WEEP HOLES AT 5" FROM EACH END AND 7" O.C.
- W2 = 1/4" X 1-1/2" LONG WEEP HOLES (4) AT MOV. PANEL AT 7" O.C.

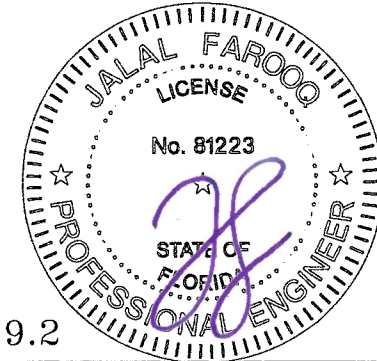

Sealed: 8/7/2020

FL #25959.2

af c

AL-FAROOQ CORPORATION
 ENGINEERS & PRODUCT DEVELOPMENT
 9360 SUNSET DRIVE, SUITE 220
 MIAMI, FLORIDA 33173 (C.A.N. 3538)
 TEL (305) 264-8100 FAX (305) 262-6978
 COMP-ANL\18-16F-MG

SERIES 1100 ALUM SLIDING GLASS DOOR (S.M.I.)
 MR-GLASS DOORS & WINDOWS MANUFACTURING, LLC
 8051 N.W. 79th Place
 Medley, FL. 33166
 Tel. (305) 764-3963 Fax. (305) 470-8285

revisions:	no	date	by	description

date: 12-28-17
 scale: 3/8" = 1"
 dr. by: TARIQ
 chk. by:

drawing no.
18-16F
 sheet 5 of 11

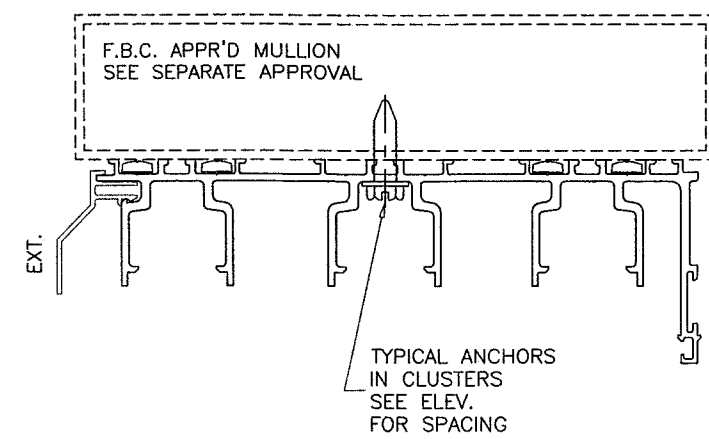
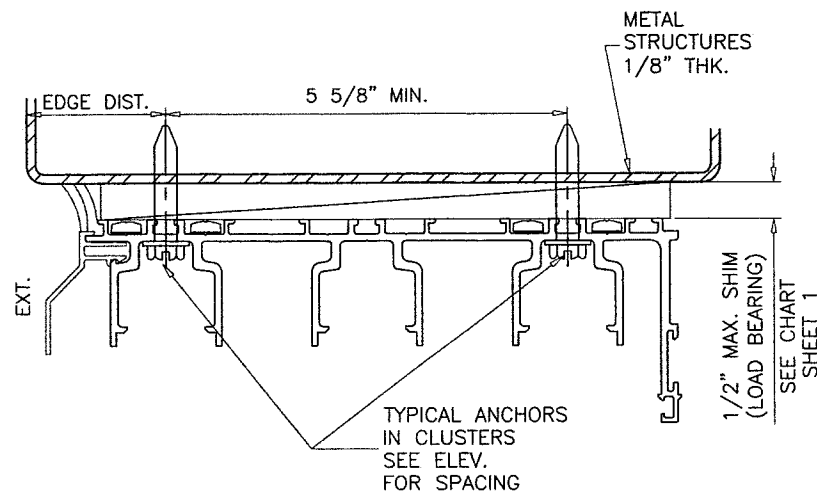
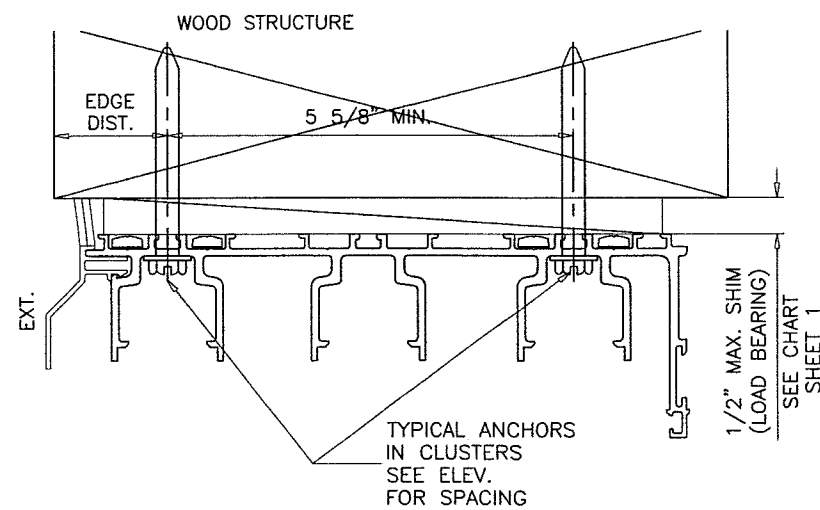

1BY OR 2BY WOOD BUCKS AND METAL STRUCTURE NOT BY MR-GLASS MUST SUSTAIN LOADS IMPOSED BY GLAZING SYSTEM AND TRANSFER THEM TO THE BUILDING STRUCTURE.

HEAD ANCHOR CLUSTERS AT INTERLOCK AND ASTRAGAL LOCATIONS CAN BE INSTALLED IN LINE AT CENTER TRACK OR IN PAIRS AT EXTERIOR AND INTERIOR TRACKS SEE SHEET 3 FOR SPACING

TYPICAL ANCHORS: SEE ELEV. FOR SPACING

AT HEAD

- TYPE 'A'- 5/16" X 2-3/4" ULTRACON BY 'DEWALT' (Fu=177 KSI, Fy=155 KSI)
 INTO WOOD STRUCTURES
 1-7/8" MIN. PENETRATION INTO WOOD
 THRU 1BY OR 2BY BUCKS INTO CONCRETE
 1-1/2" MIN. EMBED INTO CONCRETE
- TYPE 'B'- 5/16" X 2-3/4" ULTRACON BY 'DEWALT' (Fu=177 KSI, Fy=155 KSI)
 DIRECTLY INTO CONCRETE
 1-3/4" MIN. EMBED
- TYPE 'C'- 5/16" DIA. TEKS SELF DRILLING SCREWS (GRADE 5 CRS)
 INTO F.B.C. APPROVED MULLIONS
 OR
 INTO METAL STRUCTURES
 (3) THREADS MIN. TO EXTEND BEYOND METAL THICKNESS
 ALUMINUM: 1/8" THK. MIN. (6063-T5 MIN.)
 STEEL: 1/8" THK. MIN. (Fy = 36 KSI MIN.)
 (STEEL IN CONTACT WITH ALUMINUM TO BE PLATED OR PAINTED)

AT SILL

- TYPE 'D'- 5/16" DIA. ULTRACON BY 'DEWALT' (Fu=177 KSI, Fy=155 KSI)
 DIRECTLY INTO CONCRETE
 1-3/4" MIN. EMBED

ANCHOR EDGE DISTANCES

INTO CONCRETE AT HEAD/SILL = 1-3/4" MIN.
 INTO WOOD STRUCTURE = 1-1/4" MIN.
 INTO METAL STRUCTURE = 3/4" MIN.

WOOD AT HEAD SG = 0.55 MIN.
 CONCRETE AT HEAD, SILL f'c = 3000 PSI MIN.

Sealed:8/7/2020



FL #25959.2

af c
AL-FAROOQ CORPORATION
 ENGINEERS & PRODUCT DEVELOPMENT
 9360 SUNSET DRIVE, SUITE 220 (C.A.N. 3538)
 MIAMI, FLORIDA 33173
 TEL (305) 264-8100 FAX (305) 262-6978
 COMP-ANL 18-16F-MG

SERIES 1100 ALUM SLIDING GLASS DOOR (S.M.I.)
 MR-GLASS DOORS & WINDOWS MANUFACTURING, LLC
 8051 N.W. 79th Place
 Medley, FL. 33166
 Tel. (305) 764-3963 Fax. (305) 470-8285

revisions:	no	date	by	description

date: 12-28-17	scale: 3/8" = 1"	dr. by: TARIQ	chk. by:
drawing no. 18-16F			
sheet 6 of 11			

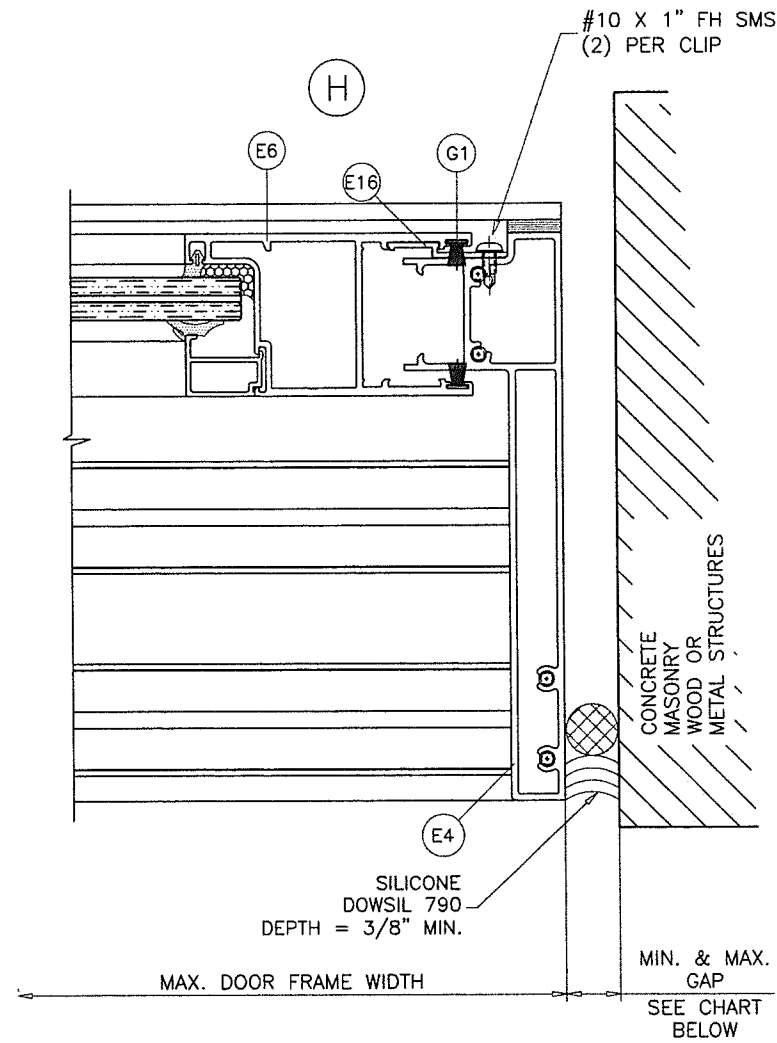

MAX. FRAME HEIGHT	GAP	
	MIN.	MAX.
90"	1/4"	3/4"
108"	5/16"	3/4"
120"	3/8"	3/4"

NOTE:
 MAX. MOVEMENT CONSIDERED=100% STRETCH.
 PLEASE REFER TO SEALANT MANUFACTURER'S DATA AND APPLICATION MANUAL FOR COMPATABILITY OF SEALANT TO SUBSTRATE & WINDOW WALL MATERIAL/FINISH AND COMPLIANCE FOR WARRANTY.
 REFER TO ACI-117-10 FOR CONSTRUCTION TOLERANCES.
 ALTERNATE SEALANTS AT JAMB GAPS CAN BE DESIGNED BY ENGINEER OF RECORD BASED ON MANUFACTURER GUIDE LINES.
 GAPS LESS THAN 1/4" MAY BE DESIGNED BY ENGINEER OF RECORD BY THE USE OF BOND BREAKER TAPE OR 15% OF GAP ALLOWED MOVEMENT.

Sealed:8/7/2020

FL #25959.2

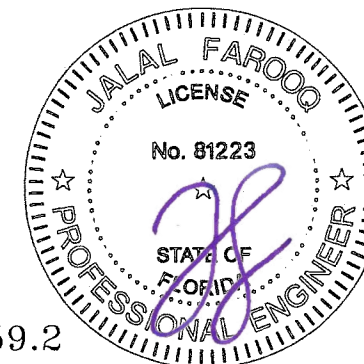

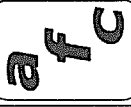

AL-FAROOQ CORPORATION
 ENGINEERS & PRODUCT DEVELOPMENT
 9360 SUNSET DRIVE, SUITE 220
 MIAMI, FLORIDA 33173 (C.A.N. 3538)
 TEL (305) 264-8100 FAX (305) 262-6978
 COMP-ANL\18-16F-MG

SERIES 1100 ALUM SLIDING GLASS DOOR (S.M.I.)
 MR-GLASS DOORS & WINDOWS MANUFACTURING, LLC
 8051 N.W. 79th Place
 Medley, FL. 33166
 Tel. (305) 764-3963 Fax. (305) 470-8285

revisions:	no	date	by	description

date: 12-28-17
 scale: 3/8" = 1"
 dr. by: TARIQ
 chk. by:

drawing no.
18-16F
 sheet 8 of 11

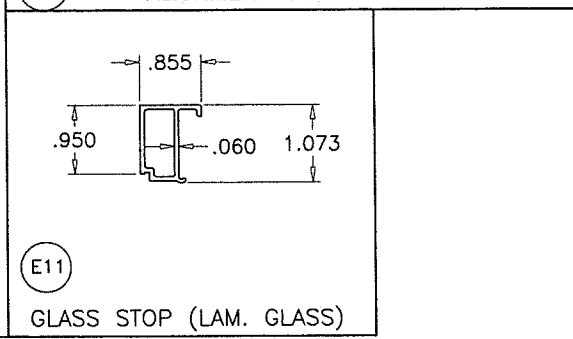
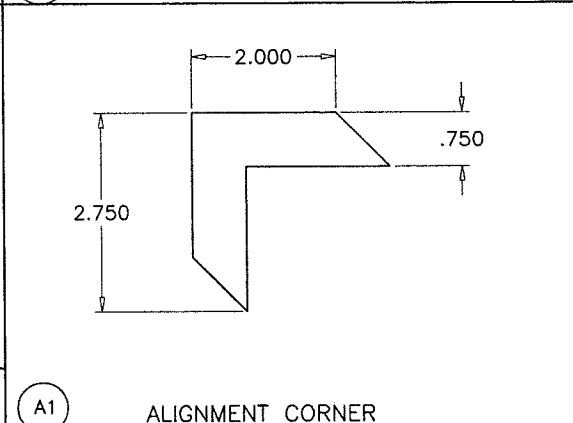
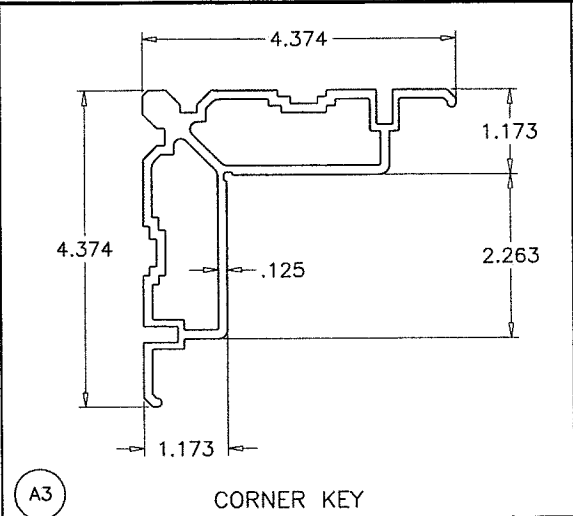
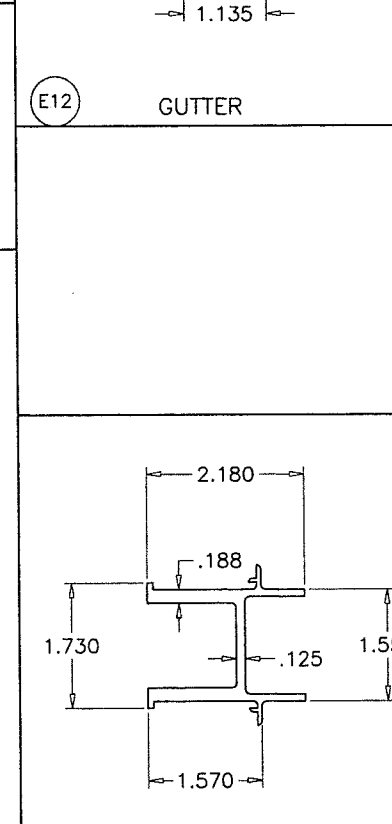
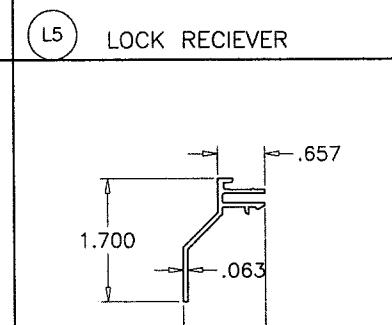
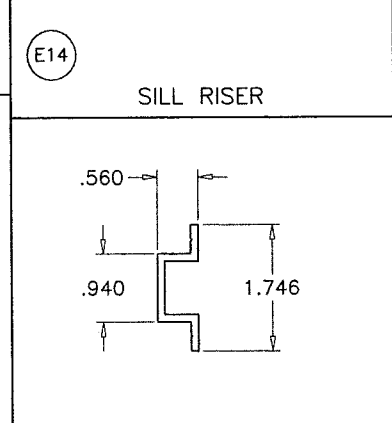
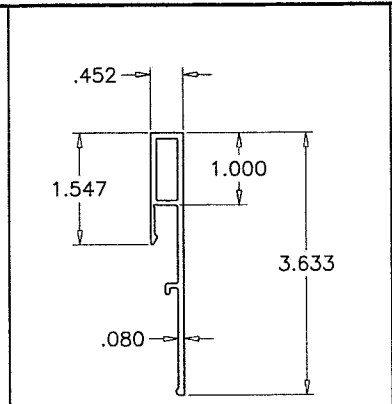
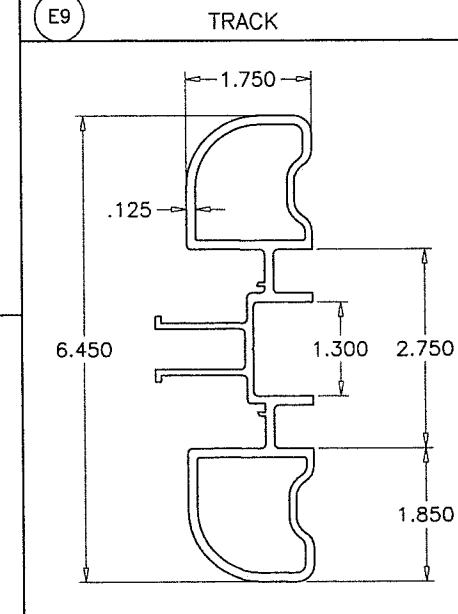
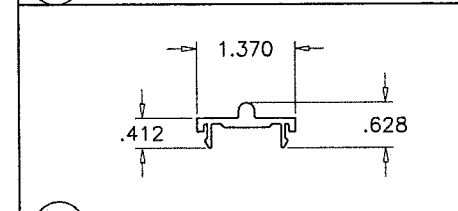
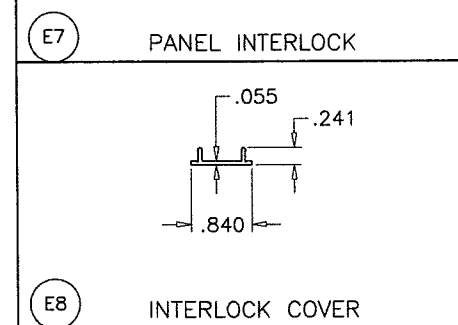
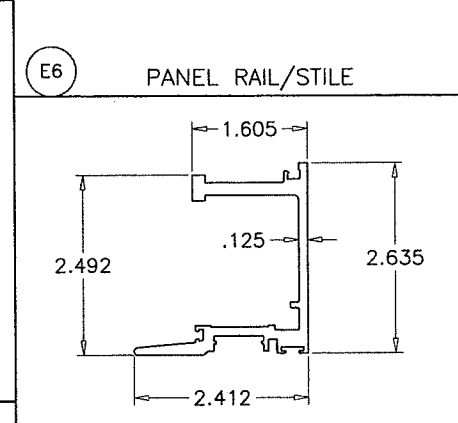
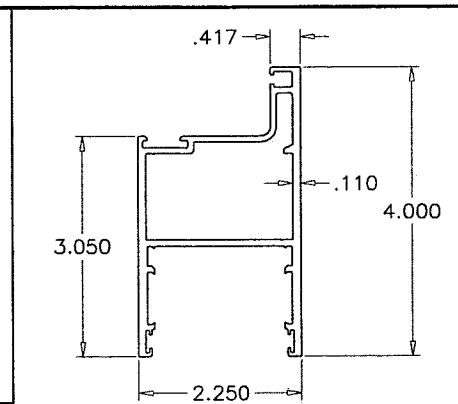
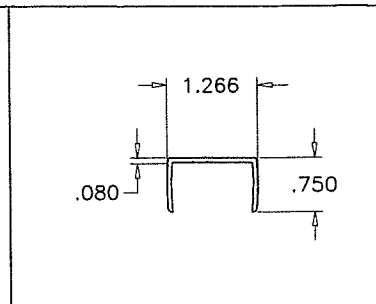
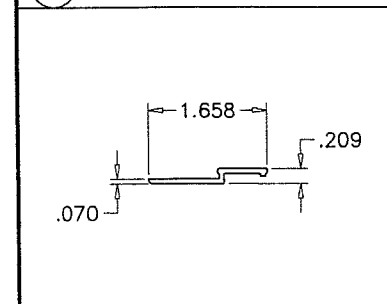
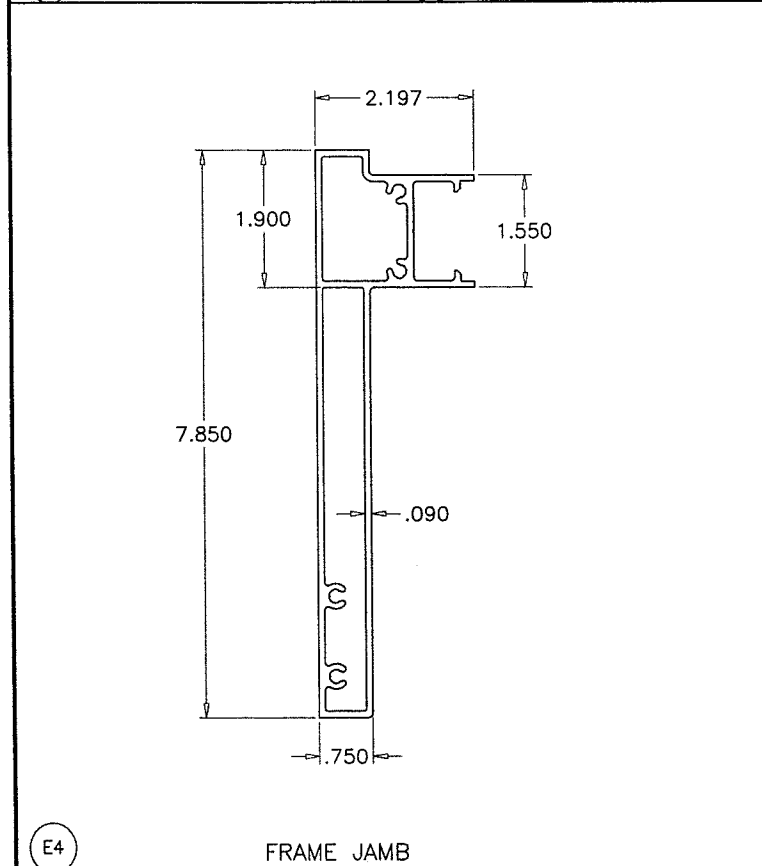
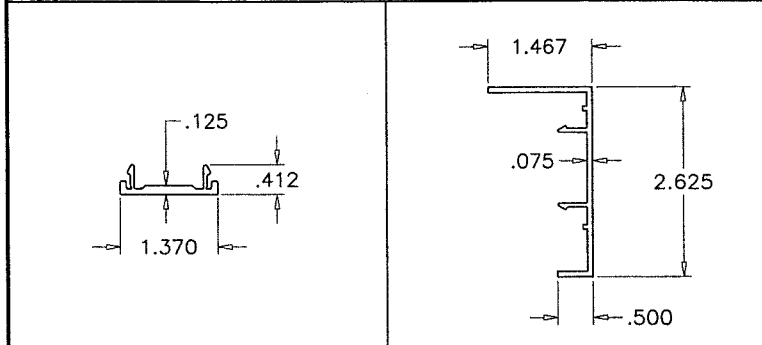
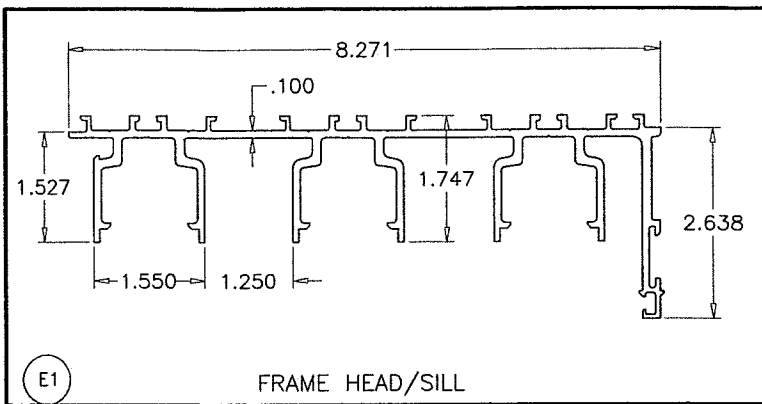

af c
AL-FAROOQ CORPORATION
 ENGINEERS & PRODUCT DEVELOPMENT
 9360 SUNSET DRIVE, SUITE 220 (C.A.N. 3538)
 MIAMI, FLORIDA 33173 FAX. (305) 262-6978
 TEL. (305) 264-8100

SERIES 1100 ALUM SLIDING GLASS DOOR (S.M.I.)
 MR-GLASS DOORS & WINDOWS MANUFACTURING, LLC
 8051 N.W. 79th Place
 Medley, FL. 33166
 Tel. (305) 764-3963 Fax. (305) 470-8285

no	date	by	description

date: 12-28-17
 scale: 3/8" = 1"
 dr. by: TARIQ
 chk. by:
 drawing no. 18-16F
 sheet 9 of 11

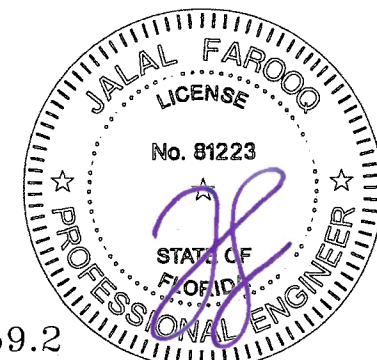

Sealed: 8/7/2020

FL #25959.2

COMP-ANL 18-16F-MG

ITEM #	PART #	QUANTITY	DESCRIPTION	MATERIAL	MANF./SUPPLIER/REMARKS
E1	E-1101	2	FRAME HEAD/SILL	6063-T6	-
E2	E-1008	AS REQD.	FRAME COVER	6063-T5	-
E3	-	AS REQD.	JAMB COVER	6063-T5	-
E4	E-1102	2	FRAME JAMB	6063-T6	-
E5	E-9006	AS REQD.	SILL COVER	6063-T5	-
E6	E-1010	AS REQD.	PANEL RAIL/STILE	6005-T5	-
E7	E-1011	AS REQD.	PANEL INTERLOCK	6005-T5	-
E8	E-1018	AS REQD.	INTERLOCK COVER	6063-T5	-
E9	E-1007	1/ MOV. PANEL	TRACK	6063-T5	-
E10	E-1013	AS REQD.	REINF. ASTRAGAL	6005-T5	-
E11	E-9001	4/ PANEL	GLASS STOP (LAM. GLASS)	6063-T6	-
E12	E-1016	AS REQD.	GUTTER	6063-T5	-
E13	E-1012	AS REQD.	STD. ASTRAGAL	6005-T5	-
E14	E-1014	AS REQD.	3-5/8" SILL RISER	6063-T6	-
E16	E-1021	3/ PANEL	FIXED PANEL CLIP, AT 17" FROM ENDS & 40" O.C.	6063-T5	EACH FASTENED WITH (2) #10 X 1" FH SMS
G1	W71325NK	AS REQD.	TRI FIN PILE W'STRIPPING	-	ULTRAFAB
G2	-	AS REQD.	COMPRESSION GASKET	EPDM	DUROMETER 70±5 SHORE A
G3	G10-03	AS REQD.	OFFSET GLAZING GASKET	SANTOPRENE	DUROMETER 70±5 SHORE A
G4	G10-04	AS REQD.	WEDGE GASKET	EPDM	DUROMETER 70±5 SHORE A
G5	G10-06	AS REQD.	AIR SEAL GASKET	SANTOPRENE	ULTRAFAB
G6	G10-06	AS REQD.	INTERLOCK GASKET	POLYPROPYLENE	ULTRAFAB
G8	-	-	1/4" THK. FOAM PAD	POLYETHYLENE	-
G9	G10-09	-	AIR SEAL BRIDGE AT INTERLOCK	POLYAMIDE	-
G10	-	-	AIR SEAL BRIDGE AT MTG. STILE	POLYAMIDE	-
G11	-	AS REQD.	SETTING BLOCKS	EPDM	DUROMETER 80±5 SHORE A
A1	A10-01	-	ALIGNMENT CORNER	6063-T5	-
A3	E-9005	-	CORNER KEY	6063-T6	-
L1	L10-01	-	2 POINT MORTISE LOCK & HANDLE	-	INTERLOCK
L2	PS01-7102	-	2 POINT MORTISE LOCK & HANDLE	-	INTERLOCK
L3	PS01-1005	-	ADJUSTABLE STRIKER	-	INTERLOCK
L5	E-1017	-	LOCK RECIEVER	6063-T5	-
M1	M10-10A	2 PANEL	ROLLER ASSEMBLY AT 9" FROM ENDS	ST. STEEL/ACETAL	FASTENED WITH (2) 12-24 X 3/4" PH MS
M6	M10-06	AS REQD.	PANEL GUIDES	NYLON	-
M7	M10-07	AS REQD.	PANEL GUIDES	NYLON	-
S1	#12 X 1 1/2"	4/ CORNER	FRAME ASSEMBLY FASTENERS	ST. STEEL	HWH SDS
S2	10-24 X 1/2"	AS REQD.	INTERLOCK FASTENERS, AT 6" FROM ENDS AND 12" O.C.	ST. STEEL	PH TC MS
S3	#8-18 X 1/2"	AS REQD.	LOCK RECIEVER FASTENERS	AISI 304	PHILIP PH SMS
S4	#10 X 1/2"	AS REQD.	PANEL ASSEMBLY FASTENERS	ST. STEEL	FH SMS

SEALANT:

ALL JOINTS AND FRAME CONNECTIONS SEALED WITH WHITE/ALUMINUM COLORED SILICONE.

LOCKS:

SURFACE MOUNT METALLIC THREE PLY DUAL HOOK LOCK AT 38-1/2" FROM BOTTOM FASTENED TO LOCK STILE WITH (2) 10-24 X 1/2" FH TC MS

SURFACE MOUNT METALLIC HANDLE AT 38-1/2" FROM BOTTOM FASTENED TO LOCK STILE WITH (2) 8-32 X 2-5/8" FH MS

SURFACE MOUNT METALLIC KEEPER FACING LOCK AT 38 1/2" FROM BOTTOM FASTENED WITH (1) #14 X 2-7/8" FH SDS AND (1) 12-24 X 1/2" PH MS

afc
AL-FAROOQ CORPORATION
 ENGINEERS & PRODUCT DEVELOPMENT
 9360 SUNSET DRIVE, SUITE 220 (C.A.N. 3538)
 MIAMI, FLORIDA 33173 FAX. (305) 262-6978
 TEL (305) 264-8100

COMP-ANL\18-16F-MG

SERIES 1100 ALUM SLIDING GLASS DOOR (S.M.I.)
 MR-GLASS DOORS & WINDOWS MANUFACTURING, LLC
 8051 N.W. 79th Place
 Medley, FL. 33166
 Tel. (305) 764-3963 Fax. (305) 470-8285

revisions:	no	date	by	description

date: 12-28-17
 scale: 3/8" = 1"
 dr. by: TARIQ
 chk. by:

drawing no.
18-16F
 sheet 10 of 11

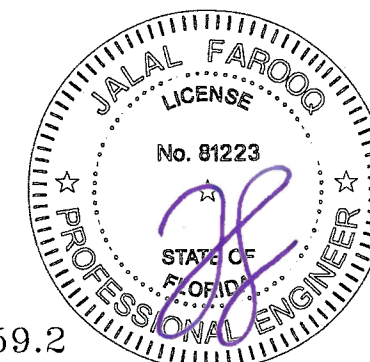

Sealed:8/7/2020

FL #25959.2

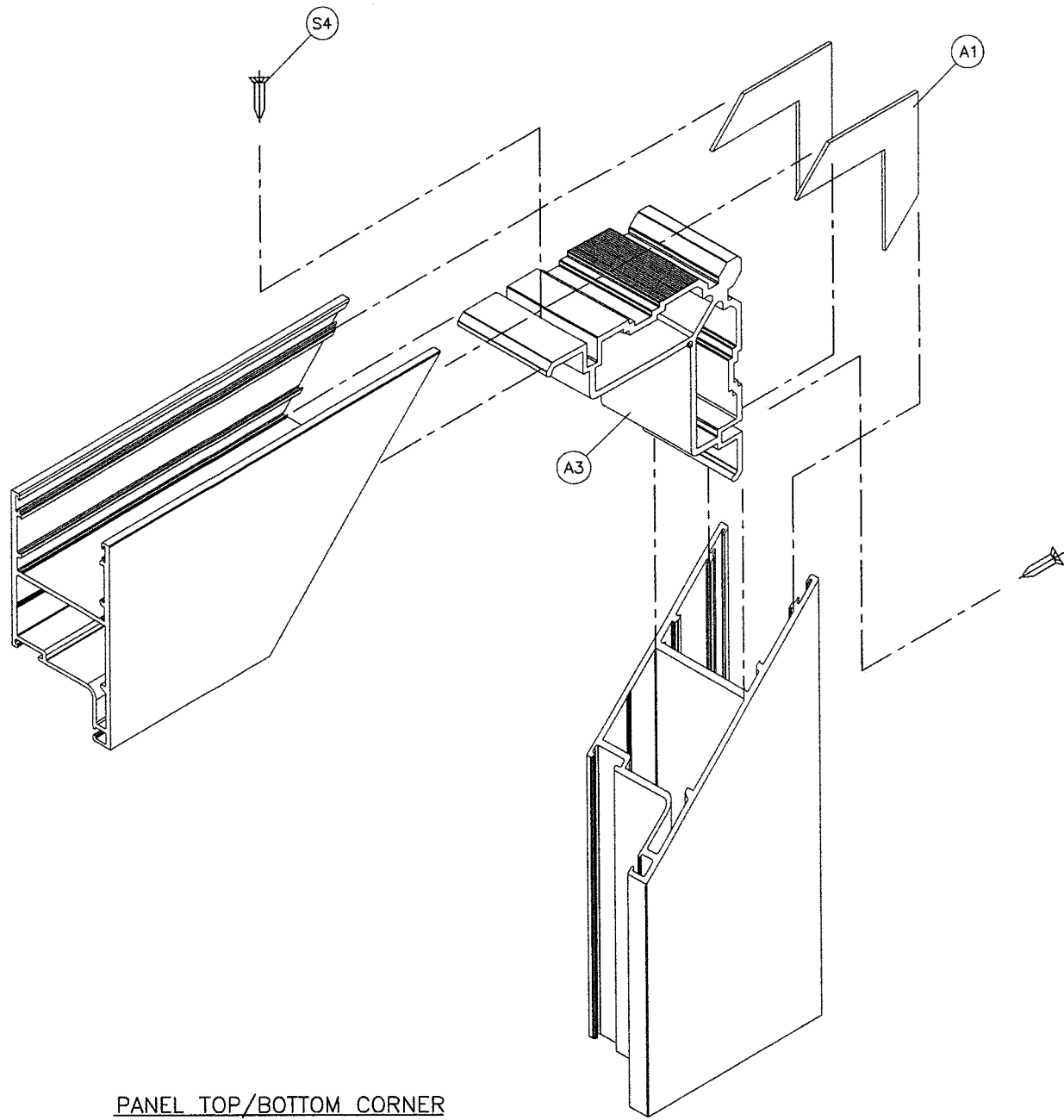

PANEL TOP/BOTTOM CORNER

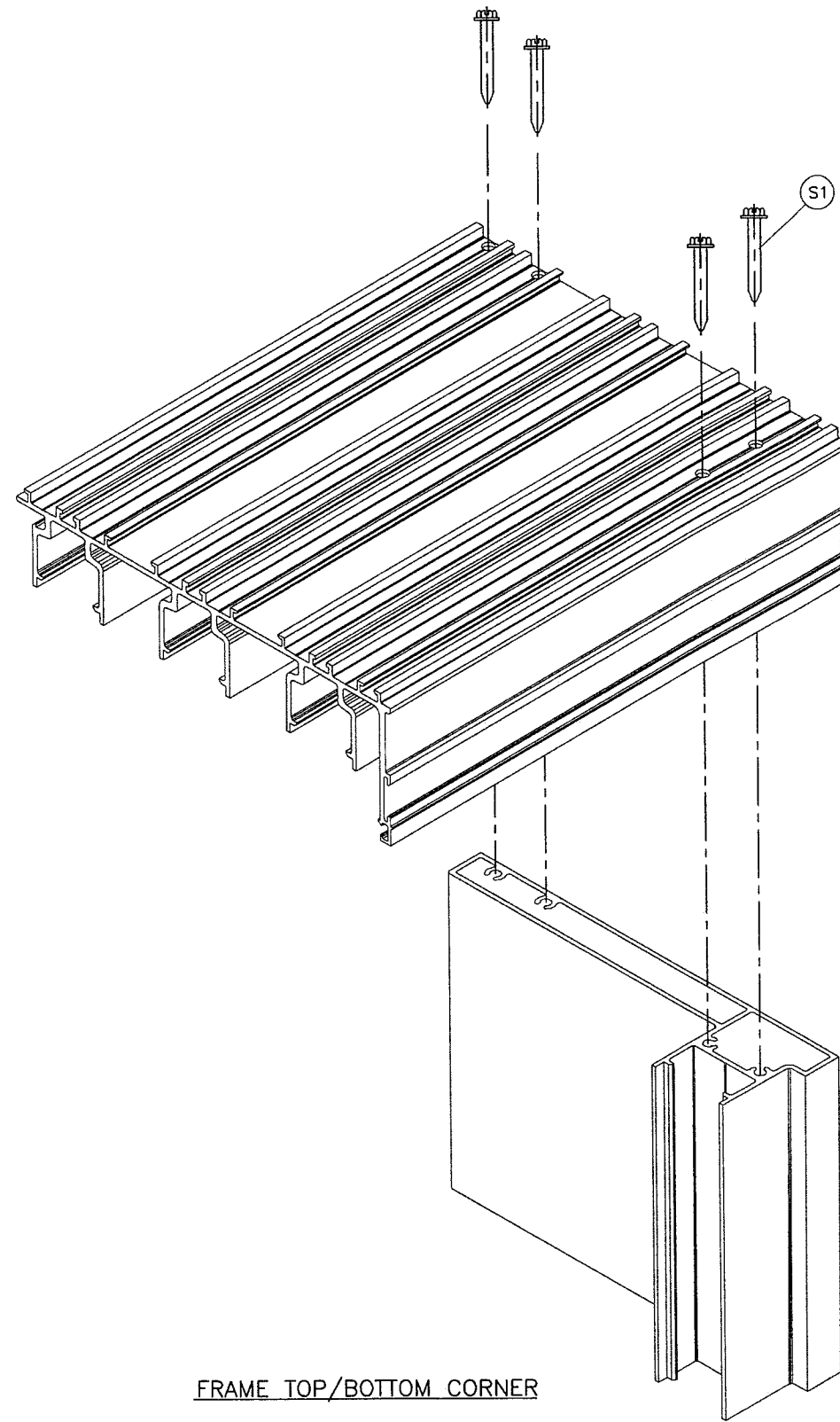

FRAME TOP/BOTTOM CORNER

Sealed: 8/7/2020

FL #25959.2

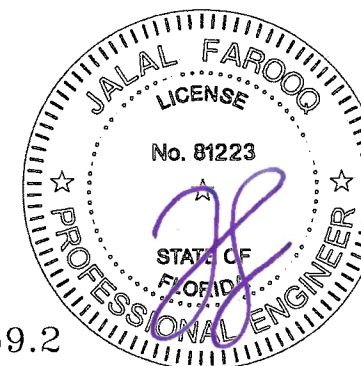

afc

AL-FAROOQ CORPORATION
 ENGINEERS & PRODUCT DEVELOPMENT
 9360 SUNSET DRIVE, SUITE 220 (C.A.N. 3538)
 MIAMI, FLORIDA 33173 TEL. (305) 262-6978 FAX. (305) 264-8100
 COMP-ANL \ 18-16F-MG

SERIES 1100 ALUM SLIDING GLASS DOOR (S.M.I.)
 MR-GLASS DOORS & WINDOWS MANUFACTURING, LLC
 8051 N.W. 79th Place
 Medley, FL. 33166
 Tel. (305) 764-3963 Fax. (305) 470-8285

revisions:	no	date	by	description

date: 12-28-17	scale: 3/8" = 1"	dr. by: TARIQ	chk. by:
drawing no.		18-16F	
sheet 11 of 11			