

REVISIONS			
REV	DESCRIPTION	DATE	APPROVED
A	REVISED PER NEW REQUIREMENTS	12/13/23	R.L.

NOTES:

1. THE PRODUCT SHOWN HEREIN IS DESIGNED AND MANUFACTURED TO COMPLY WITH REQUIREMENTS OF THE FLORIDA BUILDING CODE.
2. WOOD FRAMING, METAL STRUCTURE AND MASONRY OPENING TO BE DESIGNED AND ANCHORED TO PROPERLY TRANSFER ALL LOADS TO STRUCTURE. FRAMING AND MASONRY OPENING IS THE RESPONSIBILITY OF THE ARCHITECT OR ENGINEER OF RECORD.
3. WHERE SHIM OR BUCK THICKNESS IS LESS THAN 1-1/2" UNITS MUST BE ANCHORED THROUGH THE FRAME IN ACCORDANCE WITH MANUFACTURER'S PUBLISHED INSTALLATION INSTRUCTIONS. ANCHORS SHALL BE SECURELY FASTENED DIRECTLY INTO MASONRY, CONCRETE OR OTHER STRUCTURAL SUBSTRATE MATERIAL.
4. WHERE WOOD BUCK THICKNESS IS 1-1/2" OR GREATER, BUCK SHALL BE SECURELY FASTENED TO MASONRY, CONCRETE OR OTHER STRUCTURAL SUBSTRATE. UNITS MAY BE ANCHORED THROUGH FRAME TO SECURED WOOD BUCK IN ACCORDANCE WITH MANUFACTURER'S PUBLISHED INSTALLATION INSTRUCTIONS.
5. WHERE 1X BUCK IS NOT USED DISSIMILAR MATERIALS MUST BE SEPARATED WITH APPROVED COATING OR MEMBRANE. SELECTION OF COATING OR MEMBRANE IS THE RESPONSIBILITY OF THE ARCHITECT OR ENGINEER OF RECORD.
6. BUCKS SHALL EXTEND BEYOND UNIT FRAME INTERIOR FACE SO THAT FULL FRAME SUPPORT IS PROVIDED.
7. SHIM AS REQUIRED AT EACH ANCHOR LOCATION WITH LOAD BEARING SHIM. SHIM WHERE SPACE OF 1/16" OR GREATER OCCURS. MAXIMUM ALLOWABLE SHIM STACK TO BE 1/4".
8. SHIMS SHALL BE LOCATED, APPLIED AND MADE FROM MATERIALS AND THICKNESS CAPABLE OF SUSTAINING APPLICABLE LOADS.
9. WIND LOAD DURATION FACTOR Cd=1.6 WAS USED FOR WOOD ANCHOR CALCULATIONS.
10. FRAME MATERIAL: EXTRUDED RIGID PVC.
11. UNITS MUST BE GLAZED PER ASTM E1300 WITH SAFETY GLAZING.
12. APPROVED IMPACT PROTECTIVE SYSTEM IS REQUIRED FOR THIS PRODUCT IN WIND BORNE DEBRIS REGIONS.

13. FOR ANCHORING THROUGH FRAME INTO WOOD FRAMING OR 2X BUCK USE #12 WOOD SCREWS WITH SUFFICIENT LENGTH TO ACHIEVE A 1 1/4" MINIMUM EMBEDMENT INTO SUBSTRATE. LOCATE ANCHORS AS SHOWN IN ELEVATIONS AND INSTALLATION DETAILS.
14. FOR ANCHORING THROUGH FRAME INTO MASONRY/CONCRETE USE 1/4" TAPCONS WITH SUFFICIENT LENGTH TO ACHIEVE A 1 3/4" MINIMUM EMBEDMENT INTO SUBSTRATE WITH 1-1/2" MINIMUM EDGE DISTANCE. LOCATE ANCHORS AS SHOWN IN ELEVATIONS AND INSTALLATION DETAILS.
15. FOR ANCHORING THROUGH FRAME INTO METAL STRUCTURE USE #12 SMS OR SELF DRILLING SCREWS WITH SUFFICIENT LENGTH TO ACHIEVE 3 THREADS MINIMUM BEYOND STRUCTURE INTERIOR WALL. LOCATE ANCHORS AS SHOWN IN ELEVATIONS AND INSTALLATION DETAILS.
16. ALL FASTENERS TO BE CORROSION RESISTANT.
17. INSTALLATION ANCHORS SHALL BE INSTALLED IN ACCORDANCE WITH ANCHOR MANUFACTURER'S INSTALLATION INSTRUCTIONS AND ANCHORS SHALL NOT BE USED IN SUBSTRATES WITH STRENGTHS LESS THAN THE MINIMUM STRENGTH SPECIFIED BELOW
 - 17.1. WOOD: MINIMUM SPECIFIC GRAVITY OF G=0.42
 - 17.2. CONCRETE: MINIMUM COMPRESSIVE STRENGTH OF 2,000 PSI.
 - 17.3. MASONRY: HOLLOW/GROUT FILLED BLOCK PER ASTM C90 WITH Fm=2,000PSI MINIMUM.
 - 17.4. METAL STRUCTURE: STEEL 18GA (.048") FY=33KSI/FU=52KSI OR ALUMINUM 6063-T5 FU=30KSI .125" THICK MINIMUM

TABLE OF CONTENTS	
SHEET NO.	DESCRIPTION
1	NOTES
2	ELEVATION
3	HORIZONTAL CROSS SECTIONS
4 - 13	INSTALLATION DETAILS
14	COMPONENTS

EASTERN ARCHITECTURAL SYSTEMS 16341 DOMESTIC AVENUE FORT MYERS, FL 33192		
SERIES 650 VINYL SGD W/ & W/O POCKET CW-PG45 NON-IMPACT NOTES		
DRAWN: R.L.	DWG NO. 08-03549	REV A
SCALE NTS	DATE 04/30/2020	SHEET 1 OF 14
L. ROBERTO LOMAS P.E. 208 7th Ave, INDIALANTIC, FL 32903 434-688-0609 rllomas@lrlomaspe.com		

SIGNED: 01/03/2024

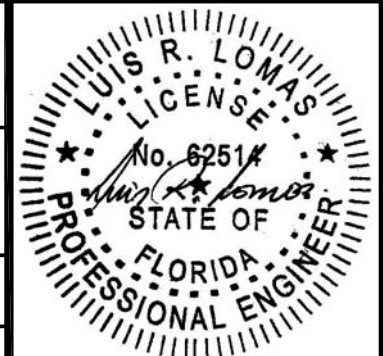

Luis R. Lomas P.E.
FL No.: 62514

REVISIONS			
REV	DESCRIPTION	DATE	APPROVED
A	REVISED PER NEW REQUIREMENTS	12/13/23	R.L.

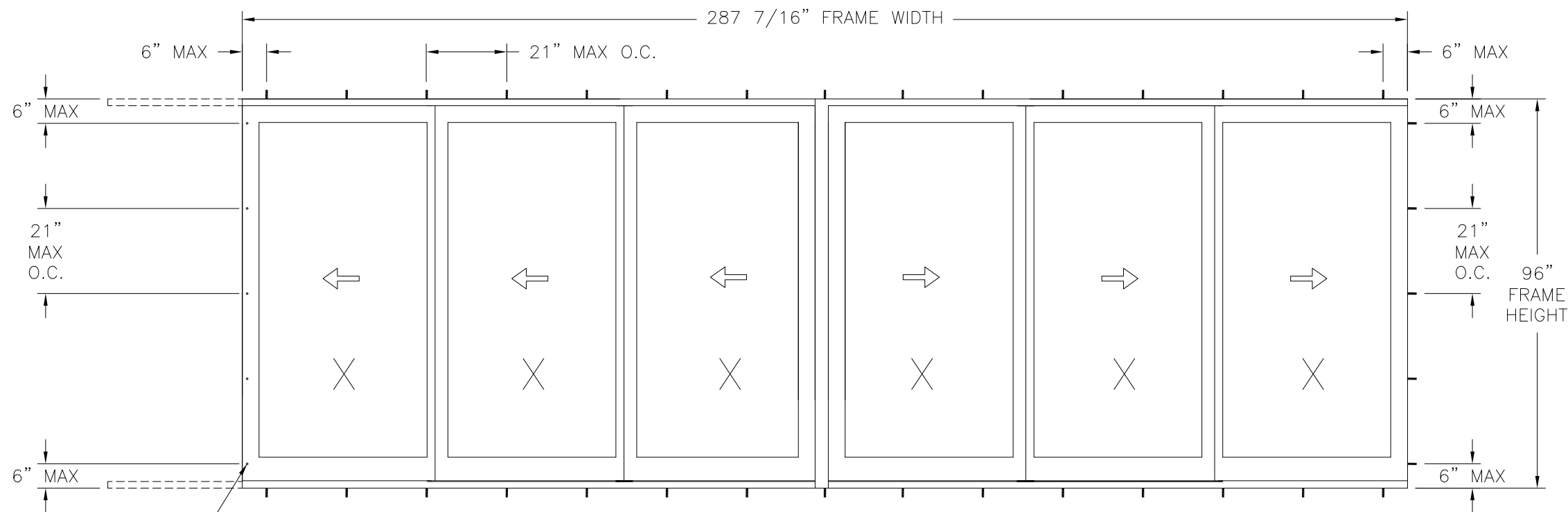

- NOTES:
- PANEL SIZE: 50 1/4" x 92 11/16"
 - MAXIMUM D.L.O.: 43 1/4" x 85 11/16"

650 VINYL SGD OXXO
EXTERIOR VIEW

DESIGN PRESSURE RATING	IMPACT RATING
±45.0 PSF	NONE

WITH 0.522" OR 1.44" OR 1.94" SILL RISER

POCKET HOOK ANCHORS

SIGNED: 01/03/2024

HARDWARE SCHEDULE	
A.	2 POINT MORTISE LOCK W/HANDLE 52 1/2" FROM TOP OF LOCK STILES
B.	METAL ASTRAGAL STILE AT LOCK JAMB
C.	1983 TANDEM AXLE & PR05 ROLLER BY AMESBURY AT BOTTOM RAILS
D.	ALUMINUM ASTRAGAL 10300233 AT ACTIVE PANEL
E.	ALUMINUM REINFORCEMENT AT PANEL TOP, BOTTOM AND LOCK STILE

EASTERN ARCHITECTURAL SYSTEMS
16341 DOMESTIC AVENUE
FORT MYERS, FL 33192

SERIES 650 VINYL SGD
W/ & W/O POCKET CW-PG45 NON-IMPACT
ELEVATION

DRAWN: R.L.	DWG NO. 08-03549	REV A
SCALE NTS	DATE 04/30/2020	SHEET 2 OF 14

L. ROBERTO LOMAS P.E.
208 7th Ave, INDIALANTIC, FL 32903
434-688-0609 rllomas@lrlomaspe.com

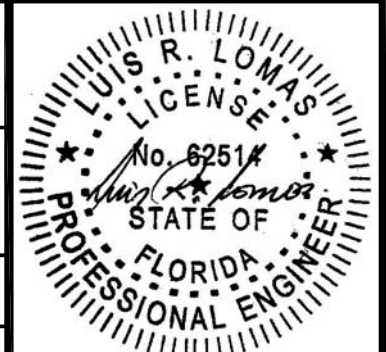

Luis R. Lomas P.E.
FL No.: 62514

HORIZONTAL CROSS SECTIONS

FOR REFERENCE ONLY, MULTIPLE CONFIGURATIONS WITH OR WITHOUT POCKET ARE APPROVED AND ARE NOT LIMITED TO SECTIONS SHOWN HEREIN.
SEE SHEET 13 FOR POCKET DETAILS
FOR INSTALLATION DETAILS SEE SHEETS 4 - 12

REVISIONS			
REV	DESCRIPTION	DATE	APPROVED
A	REVISED PER NEW REQUIREMENTS	12/13/23	R.L.

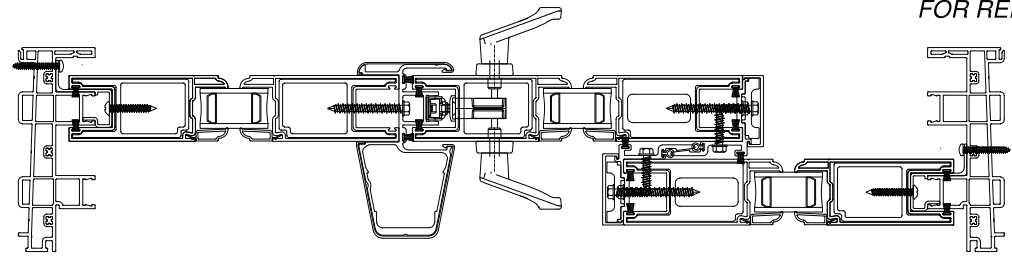

OXO

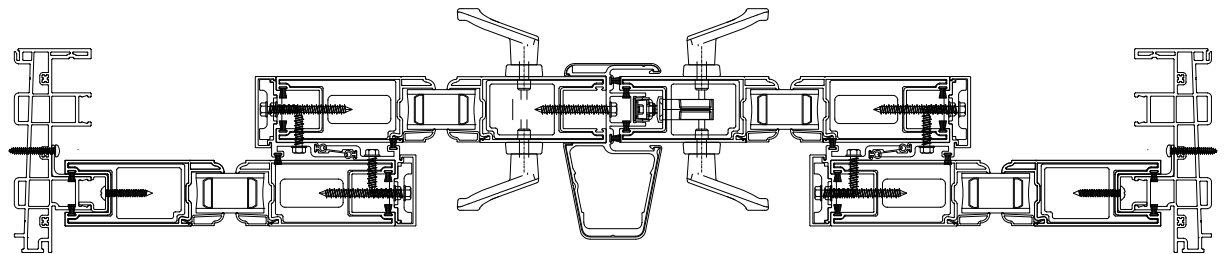

OXXO

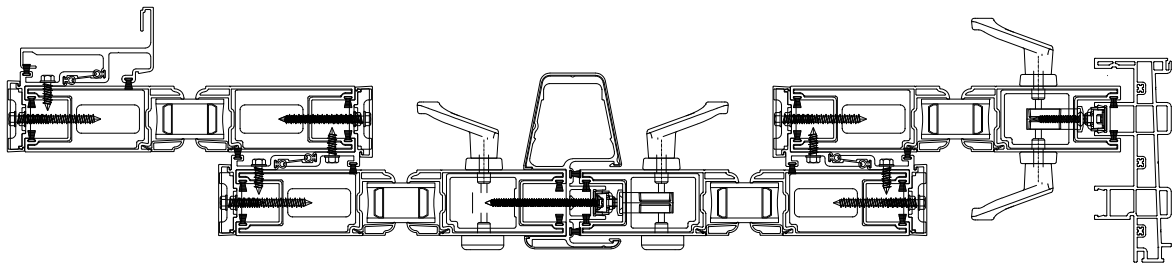

PXXXX

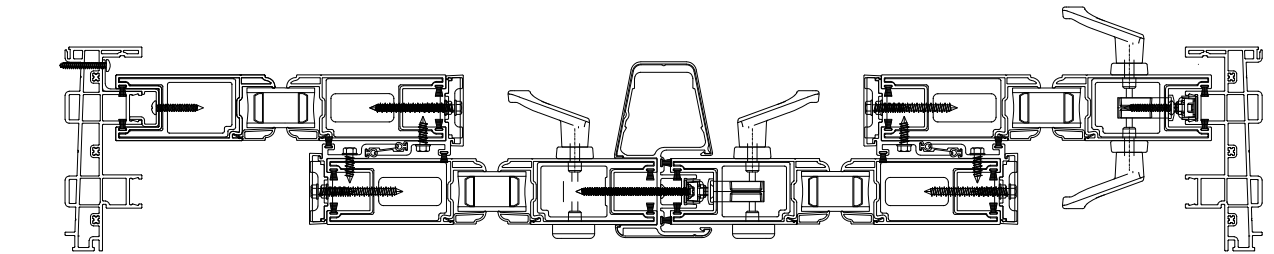

OXXX, XXXO

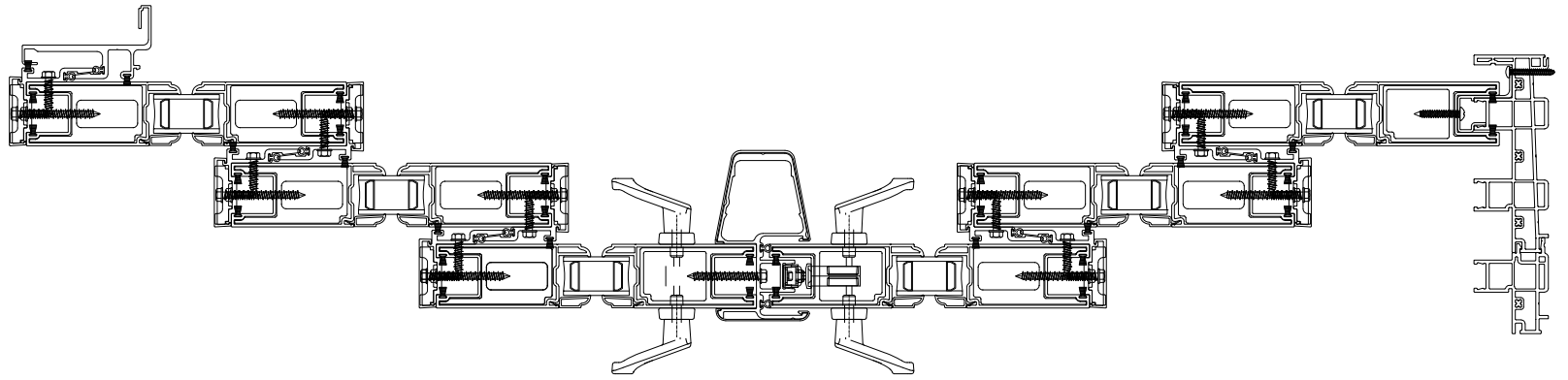

PXXXXXX

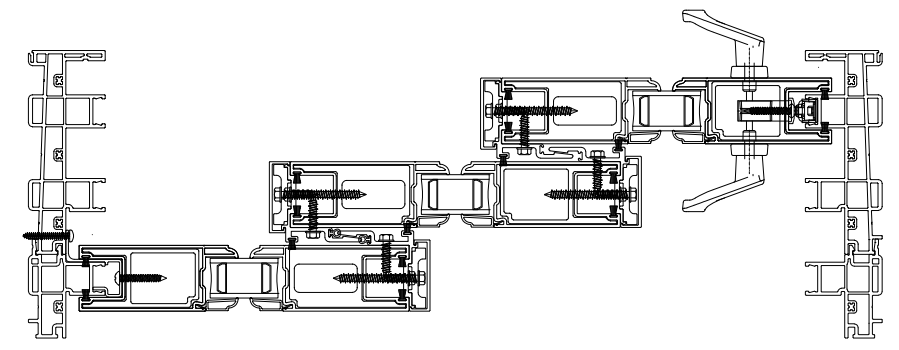

OXX, XXO

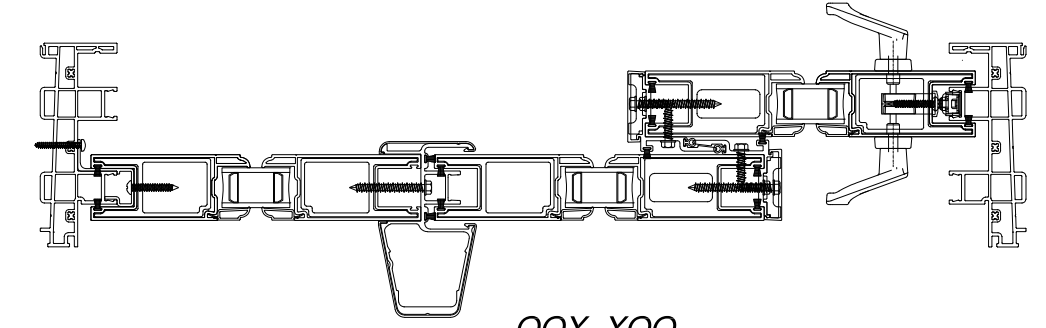

OOX, XOO

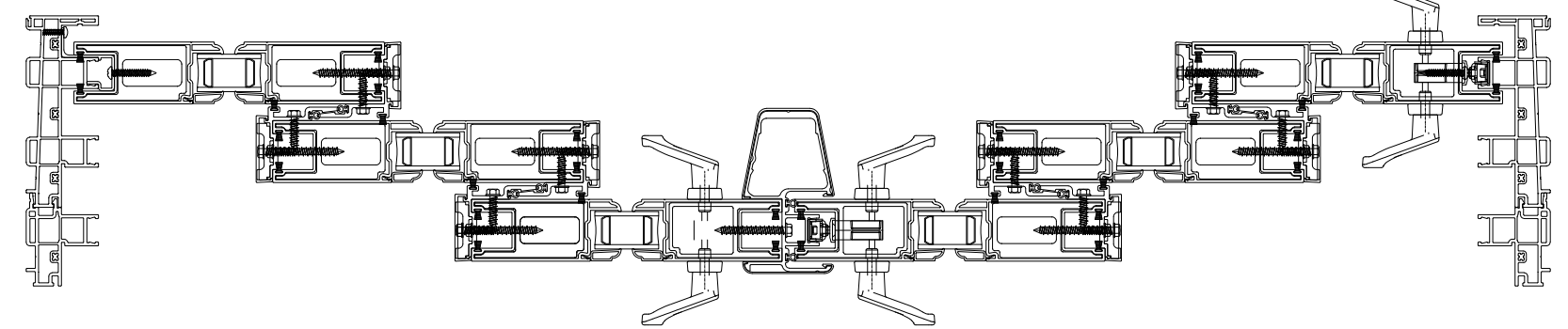

OXXXXX, XXXXO

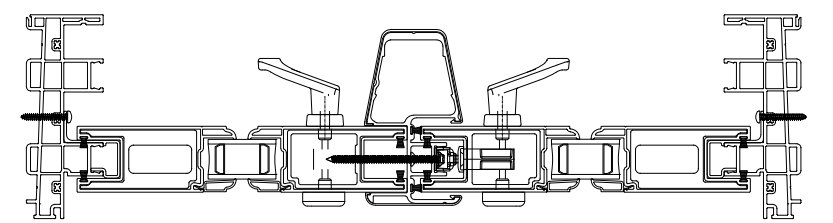

OO

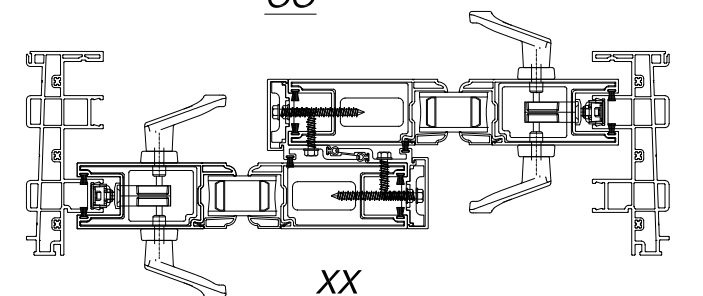

XX

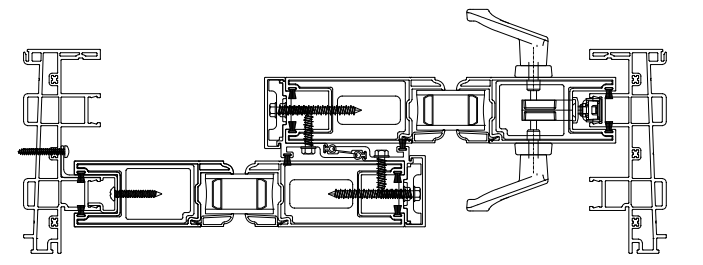

OX, XO

SIGNED: 01/03/2024

EASTERN ARCHITECTURAL SYSTEMS
16341 DOMESTIC AVENUE
FORT MYERS, FL 33192

SERIES 650 VINYL SGD
W/ & W/O POCKET CW-PG45 NON-IMPACT
HORIZONTAL CROSS SECTIONS

DRAWN: R.L.	DWG NO. 08-03549	REV A
SCALE NTS	DATE 04/30/2020	SHEET 3 OF 14

L. ROBERTO LOMAS P.E.
208 7th Ave, INDIALANTIC, FL 32903
434-688-0609 rllomas@lrlomaspe.com

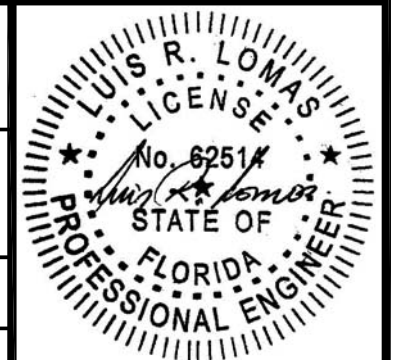

Luis R. Lomas P.E.
FL No.: 62514

REVISIONS			
REV	DESCRIPTION	DATE	APPROVED
A	REVISED PER NEW REQUIREMENTS	12/13/23	R.L.

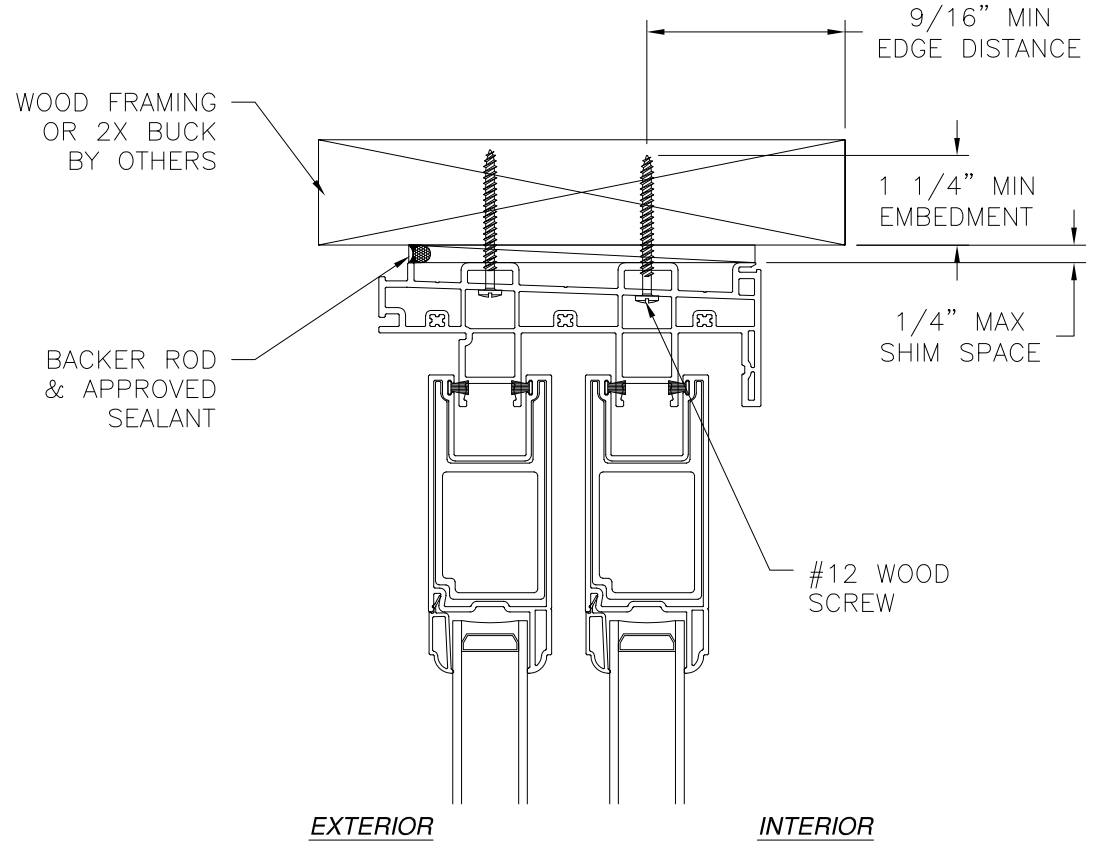

EXTERIOR INTERIOR

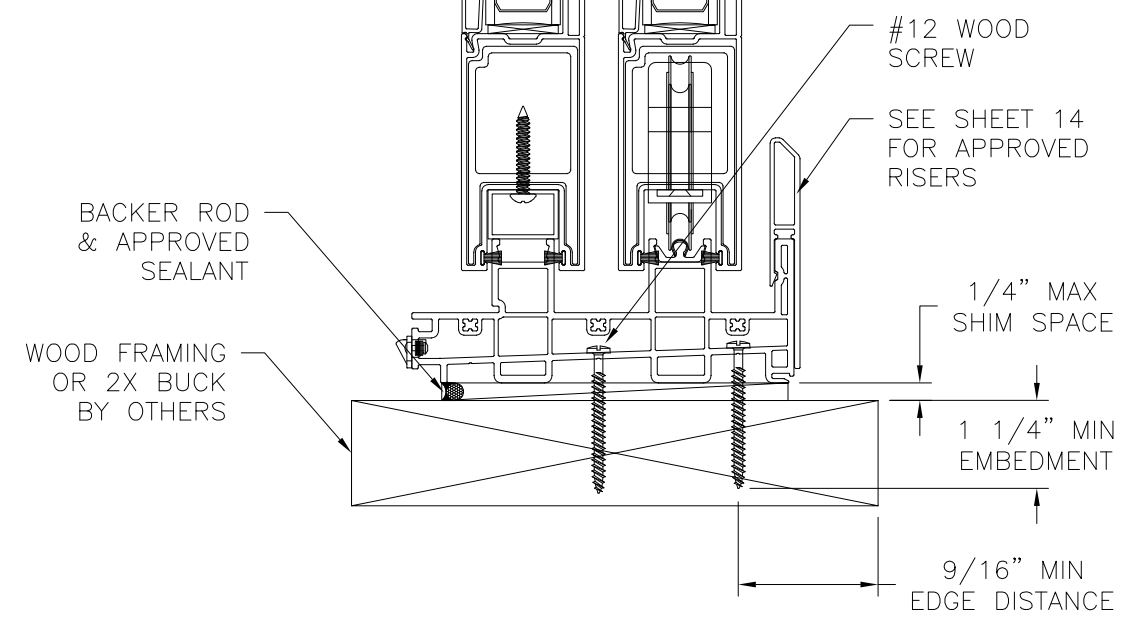

VERTICAL CROSS SECTION
WOOD FRAMING OR 2X BUCK INSTALLATION

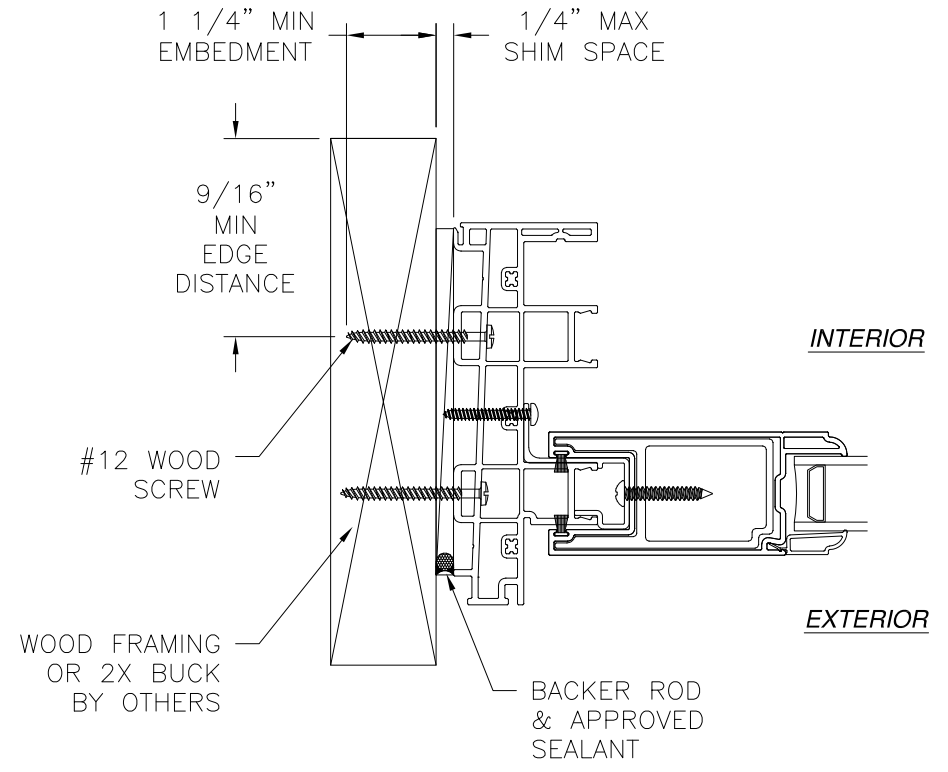

JAMB INSTALLATION DETAIL
WOOD FRAMING OR 2X BUCK INSTALLATION

- NOTES:**
1. INTERIOR AND EXTERIOR FINISHES, BY OTHERS, NOT SHOWN FOR CLARITY.
 2. PERIMETER AND JOINT SEALANT BY OTHERS TO BE DESIGNED IN ACCORDANCE WITH ASTM E2112

SIGNED: 01/03/2024

EASTERN ARCHITECTURAL SYSTEMS 16341 DOMESTIC AVENUE FORT MYERS, FL 33192		
SERIES 650 VINYL SGD W/ & W/O POCKET CW-PG45 NON-IMPACT 2TRACK INSTALLATION DETAILS		
DRAWN: R.L.	DWG NO. 08-03549	REV A
SCALE NTS	DATE 04/30/2020	SHEET 4 OF 14
L. ROBERTO LOMAS P.E. 208 7th Ave, INDIALANTIC, FL 32903 434-688-0609 rllomas@lrlomaspe.com		

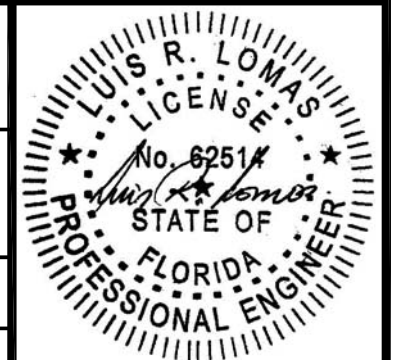

Luis R. Lomas P.E.
FL No.: 62514

REVISIONS			
REV	DESCRIPTION	DATE	APPROVED
A	REVISED PER NEW REQUIREMENTS	12/13/23	R.L.

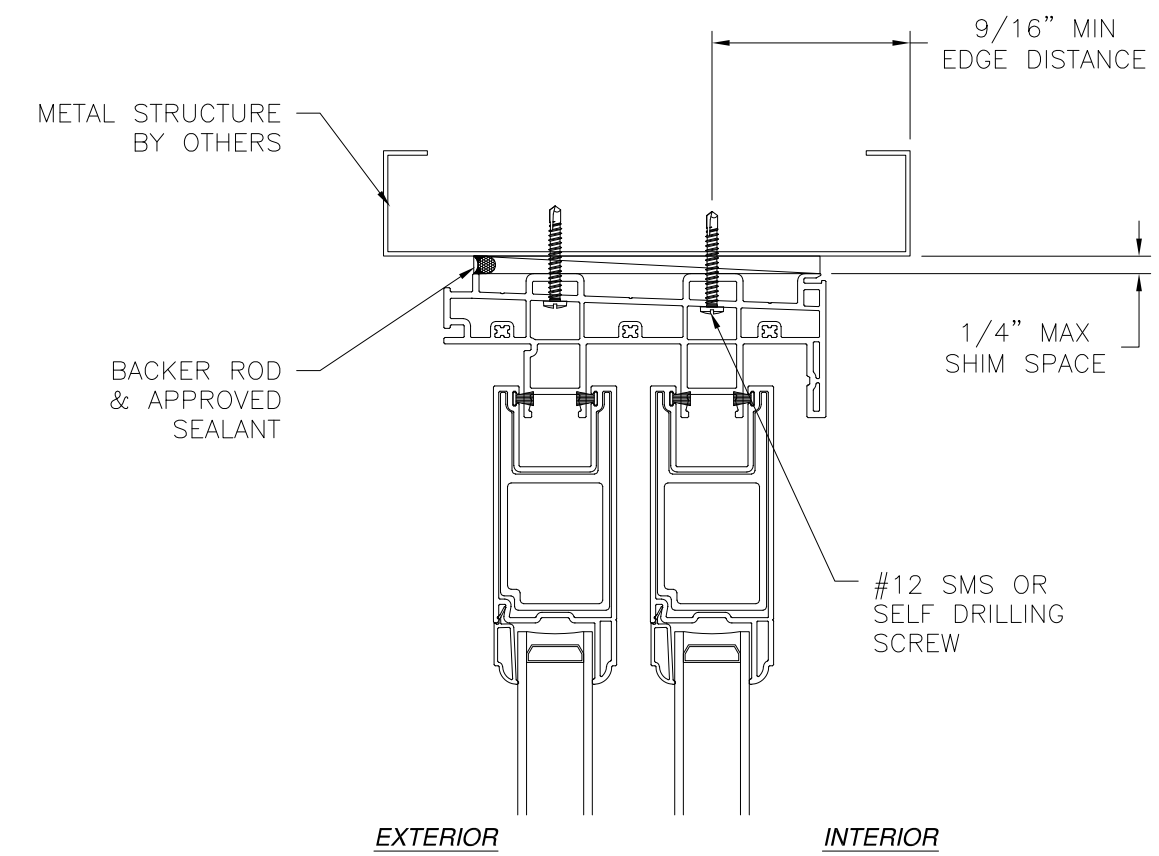

EXTERIOR INTERIOR

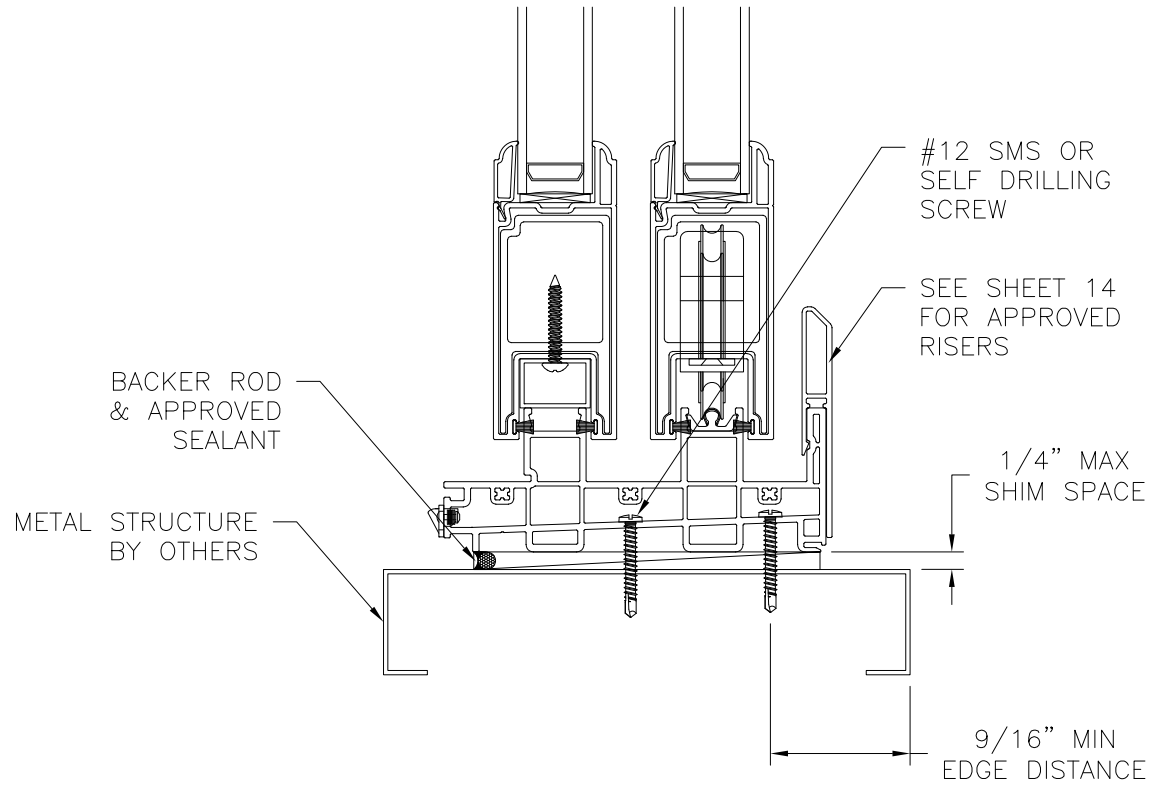

VERTICAL CROSS SECTION
METAL STRUCTURE INSTALLATION

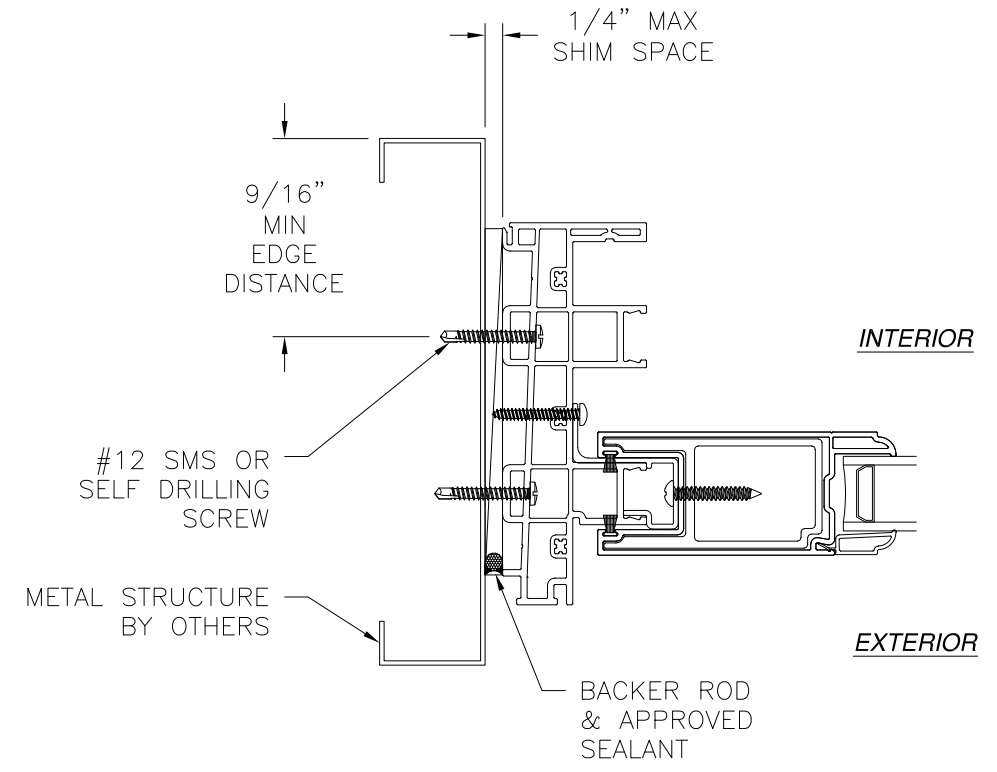

JAMB INSTALLATION DETAIL
METAL STRUCTURE INSTALLATION

- NOTES:**
- INTERIOR AND EXTERIOR FINISHES, BY OTHERS, NOT SHOWN FOR CLARITY.
 - PERIMETER AND JOINT SEALANT BY OTHERS TO BE DESIGNED IN ACCORDANCE WITH ASTM E2112

EASTERN ARCHITECTURAL SYSTEMS
16341 DOMESTIC AVENUE
FORT MYERS, FL 33192

SERIES 650 VINYL SGD
W/ & W/O POCKET CW-PG45 NON-IMPACT
2TRACK INSTALLATION DETAILS

DRAWN: R.L.	DWG NO. 08-03549	REV A
SCALE NTS	DATE 04/30/2020	SHEET 5 OF 14

L. ROBERTO LOMAS P.E.
208 7th Ave, INDIALANTIC, FL 32903
434-688-0609 rllomas@rlomaspe.com

SIGNED: 01/03/2024

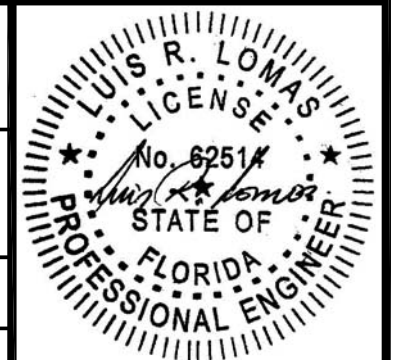

Luis R. Lomas P.E.
FL No.: 62514

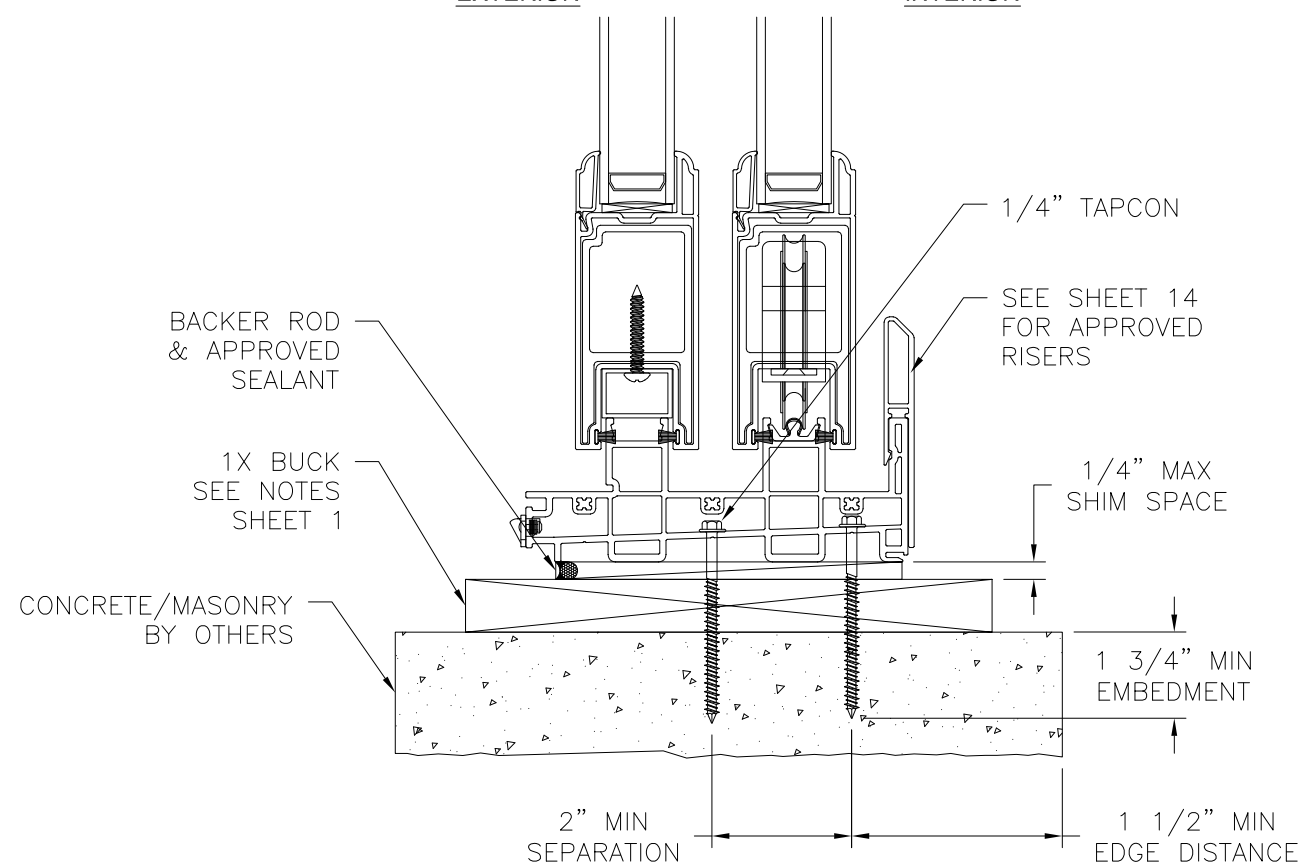
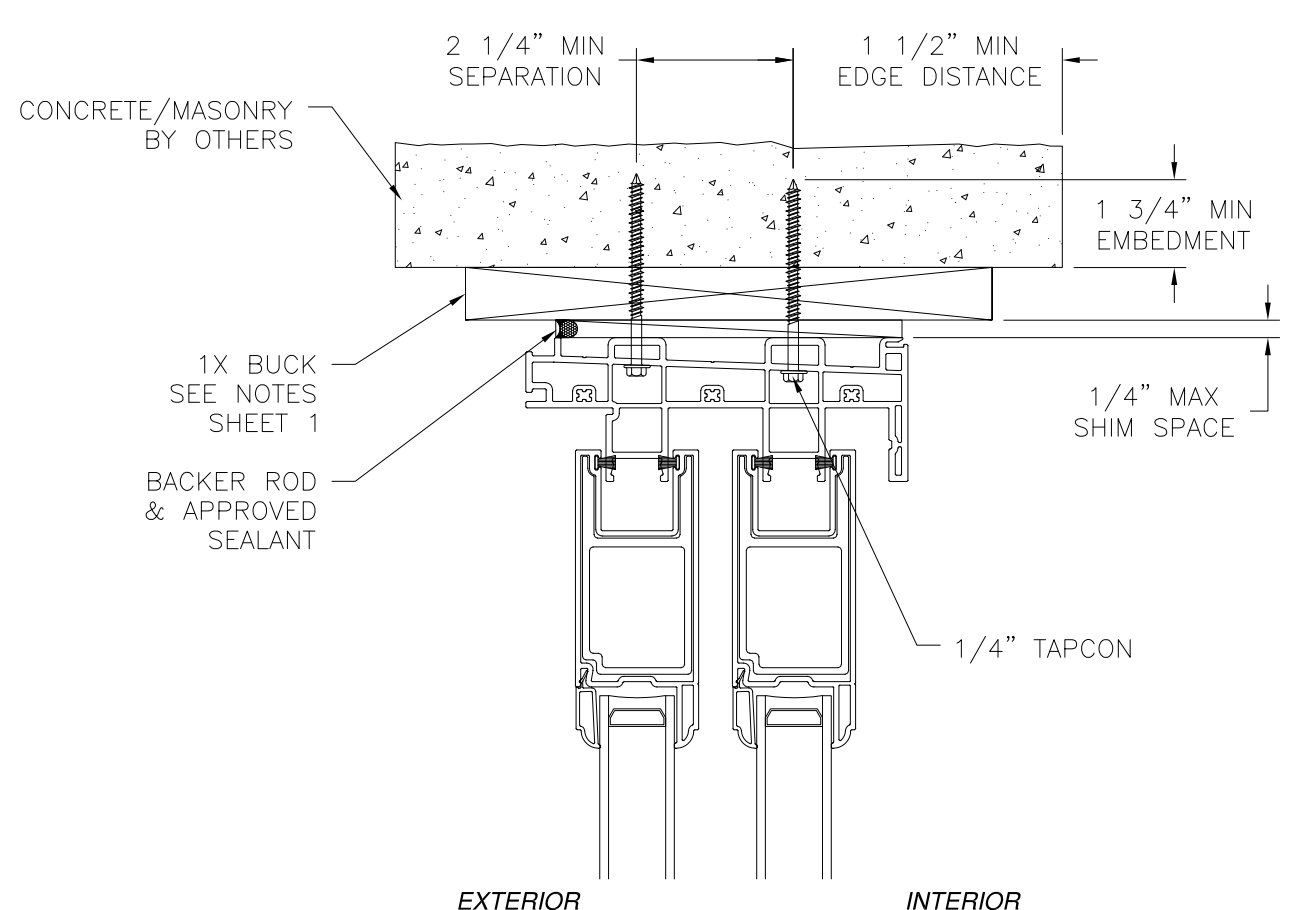

VERTICAL CROSS SECTION
CONCRETE/MASONRY INSTALLATION

REVISIONS			
REV	DESCRIPTION	DATE	APPROVED
A	REVISED PER NEW REQUIREMENTS	12/13/23	R.L.

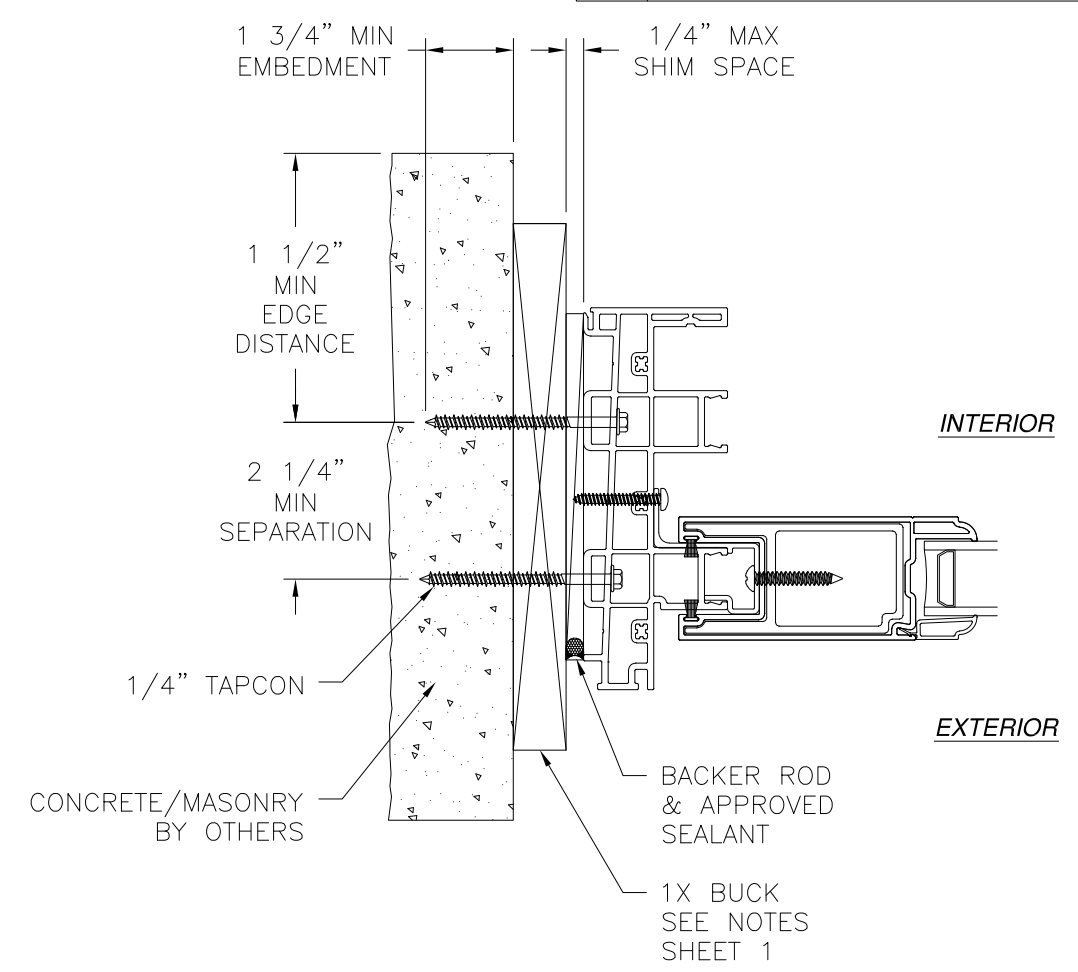

JAMB INSTALLATION DETAIL
CONCRETE/MASONRY INSTALLATION

- NOTES:**
1. INTERIOR AND EXTERIOR FINISHES, BY OTHERS, NOT SHOWN FOR CLARITY.
 2. PERIMETER AND JOINT SEALANT BY OTHERS TO BE DESIGNED IN ACCORDANCE WITH ASTM E2112

SIGNED: 01/03/2024

EASTERN ARCHITECTURAL SYSTEMS
16341 DOMESTIC AVENUE
FORT MYERS, FL 33192

SERIES 650 VINYL SGD
W/ & W/O POCKET CW-PG45 NON-IMPACT
2TRACK INSTALLATION DETAILS

DRAWN: R.L.	DWG NO. 08-03549	REV A
SCALE NTS	DATE 04/30/2020	SHEET 6 OF 14

L. ROBERTO LOMAS P.E.
208 7th Ave, INDIALANTIC, FL 32903
434-688-0609 rllomas@rlomaspe.com

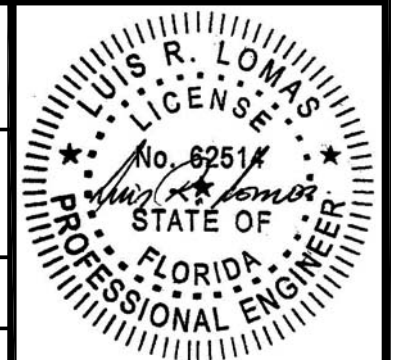

Luis R. Lomas P.E.
FL No.: 62514

REVISIONS			
REV	DESCRIPTION	DATE	APPROVED
A	REVISED PER NEW REQUIREMENTS	12/13/23	R.L.

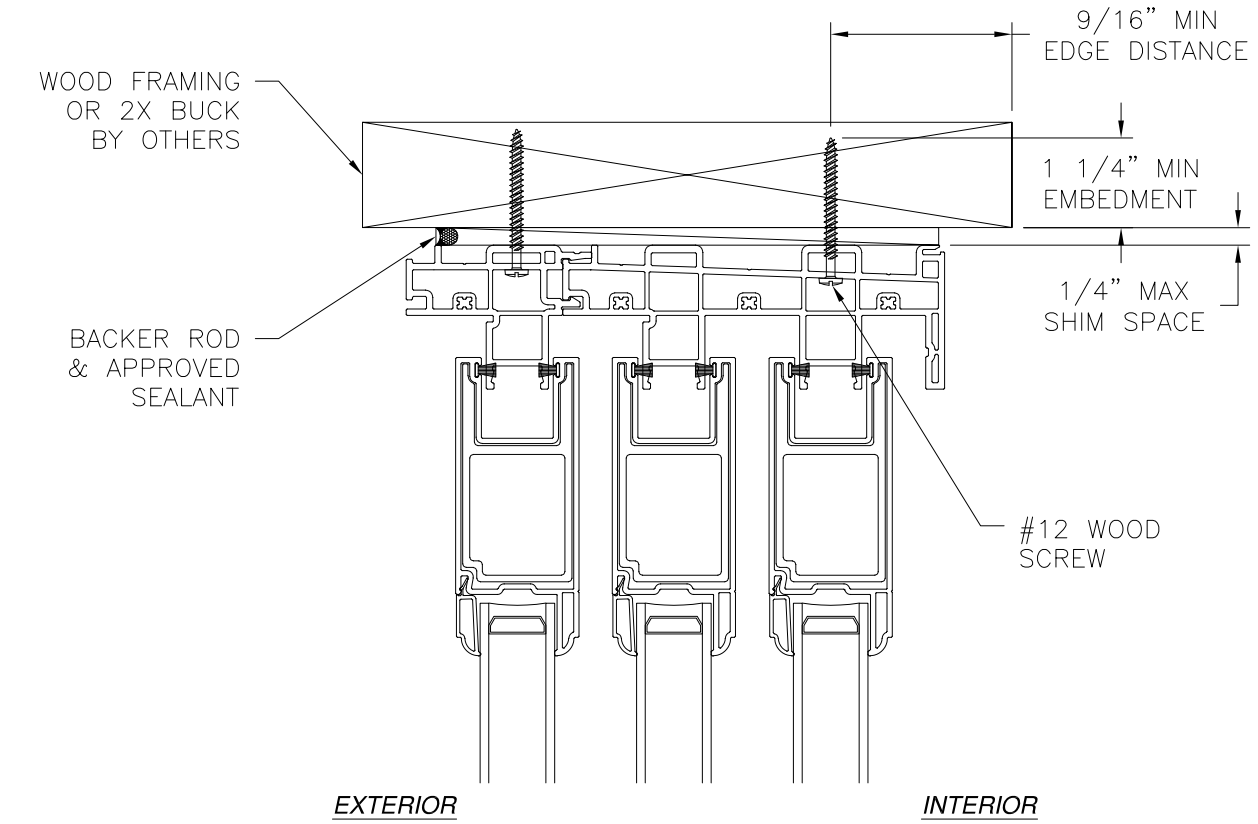

EXTERIOR INTERIOR

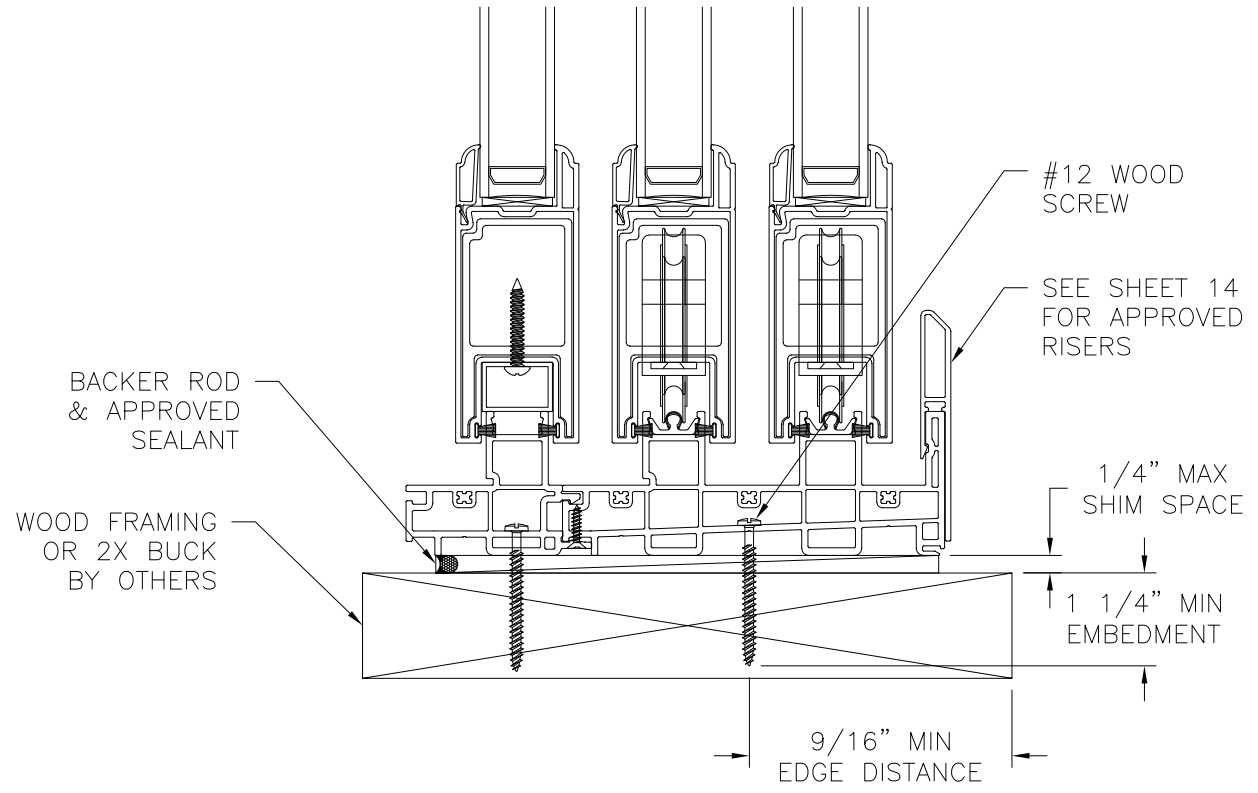

VERTICAL CROSS SECTION
WOOD FRAMING OR 2X BUCK INSTALLATION

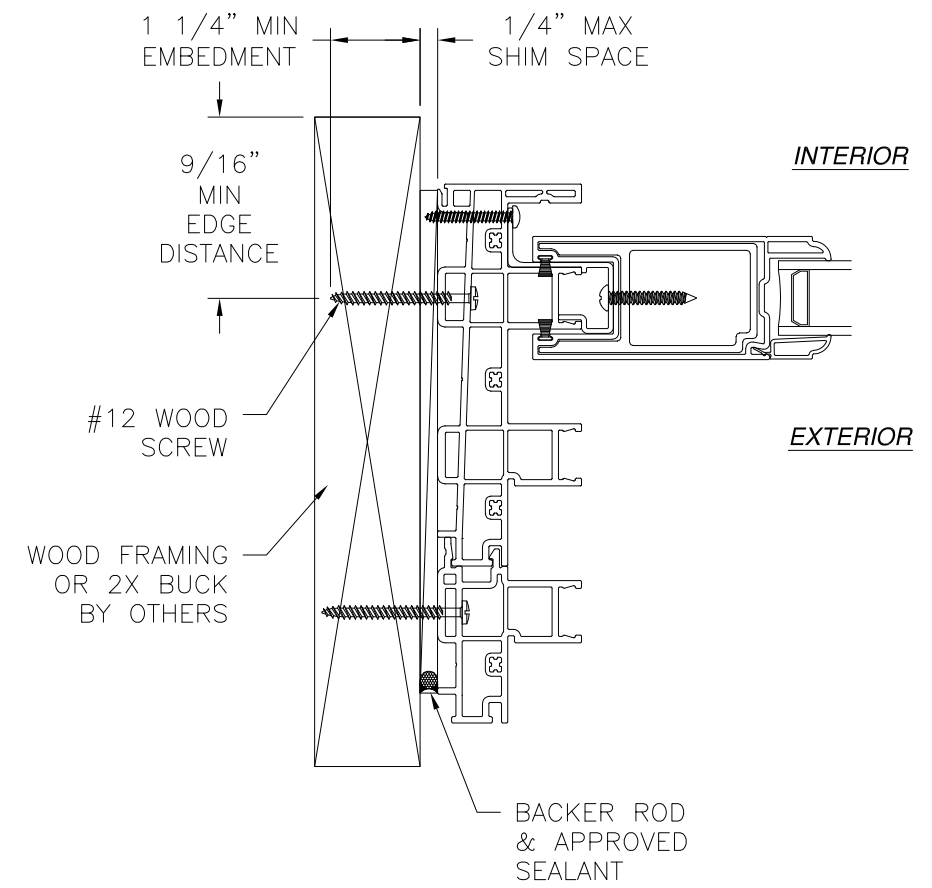

JAMB INSTALLATION DETAIL
WOOD FRAMING OR 2X BUCK INSTALLATION

- NOTES:**
1. INTERIOR AND EXTERIOR FINISHES, BY OTHERS, NOT SHOWN FOR CLARITY.
 2. PERIMETER AND JOINT SEALANT BY OTHERS TO BE DESIGNED IN ACCORDANCE WITH ASTM E2112

EASTERN ARCHITECTURAL SYSTEMS 16341 DOMESTIC AVENUE FORT MYERS, FL 33192		
SERIES 650 VINYL SGD W/ & W/O POCKET CW-PG45 NON-IMPACT 3TRACK INSTALLATION DETAILS		
DRAWN: R.L.	DWG NO. 08-03549	REV A
SCALE NTS	DATE 04/30/2020	SHEET 7 OF 14
L. ROBERTO LOMAS P.E. 208 7th Ave, INDIALANTIC, FL 32903 434-688-0609 rllomas@rlomaspe.com		

SIGNED: 01/03/2024

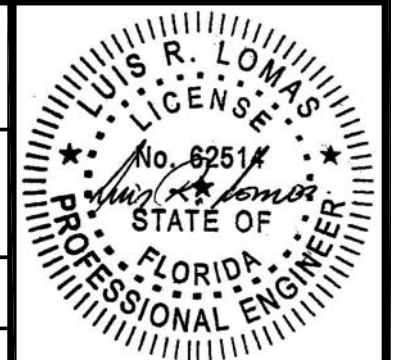

Luis R. Lomas P.E.
FL No.: 62514

REVISIONS			
REV	DESCRIPTION	DATE	APPROVED
A	REVISED PER NEW REQUIREMENTS	12/13/23	R.L.

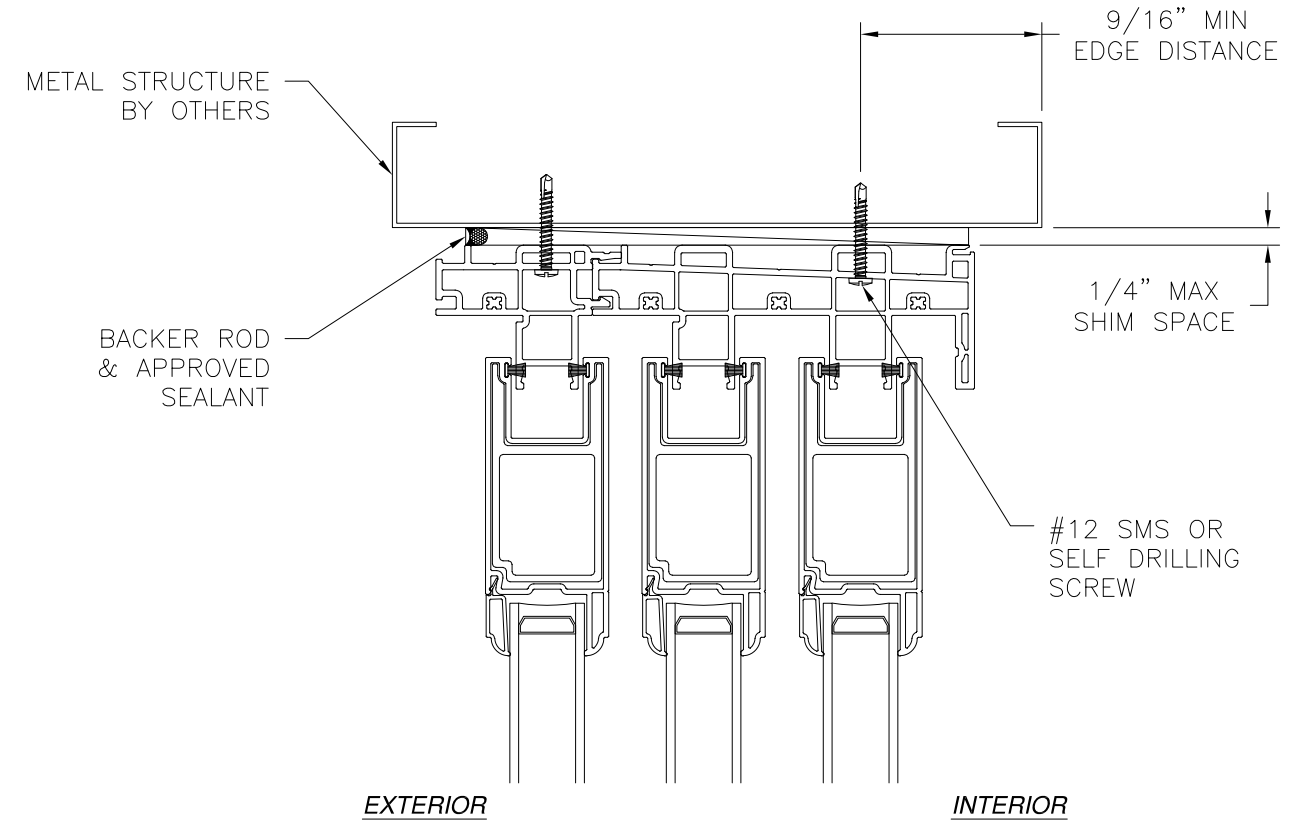

VERTICAL CROSS SECTION
METAL STRUCTURE INSTALLATION

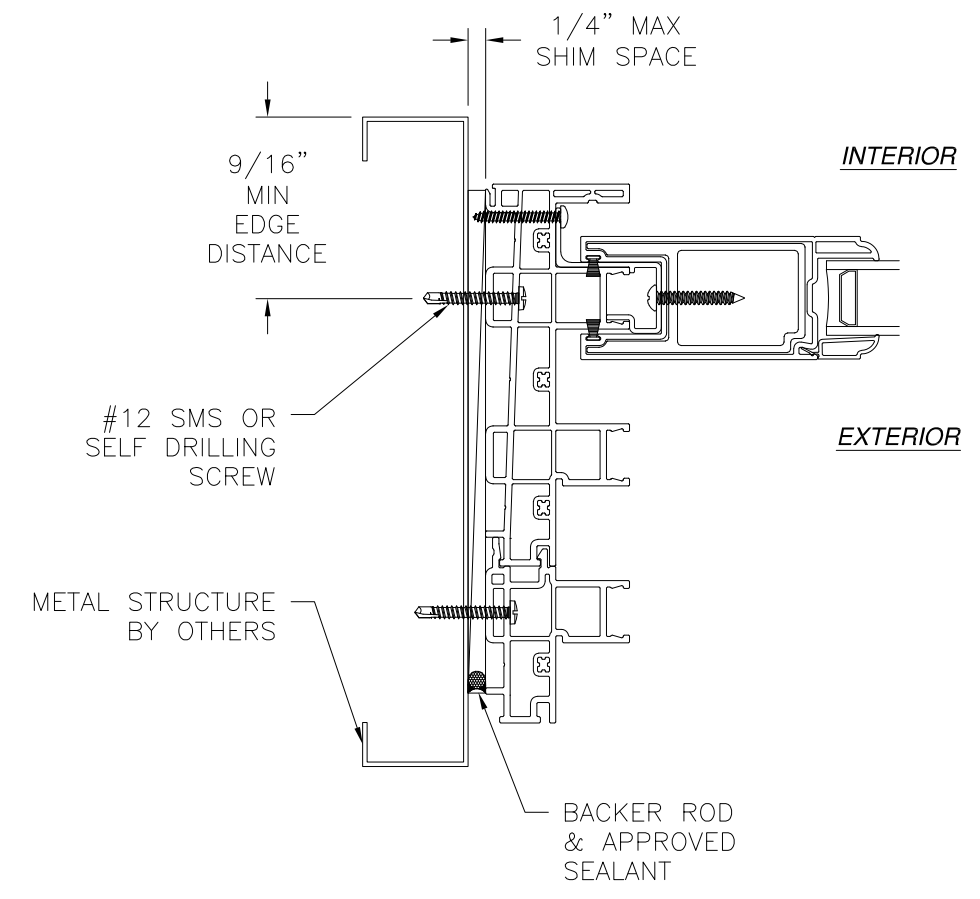

JAMB INSTALLATION DETAIL
METAL STRUCTURE INSTALLATION

- NOTES:**
- INTERIOR AND EXTERIOR FINISHES, BY OTHERS, NOT SHOWN FOR CLARITY.
 - PERIMETER AND JOINT SEALANT BY OTHERS TO BE DESIGNED IN ACCORDANCE WITH ASTM E2112

SIGNED: 01/03/2024

EASTERN ARCHITECTURAL SYSTEMS 16341 DOMESTIC AVENUE FORT MYERS, FL 33192		
SERIES 650 VINYL SGD W/ & W/O POCKET CW-PG45 NON-IMPACT 3TRACK INSTALLATION DETAILS		
DRAWN: R.L.	DWG NO. 08-03549	REV A
SCALE NTS	DATE 04/30/2020	SHEET 8 OF 14
L. ROBERTO LOMAS P.E. 208 7th Ave, INDIALANTIC, FL 32903 434-688-0609 rllomas@rlomaspe.com		

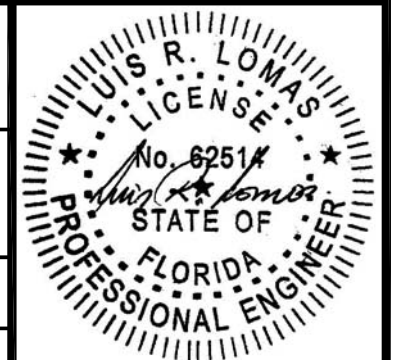

Luis R. Lomas P.E.
FL No.: 62514

REVISIONS			
REV	DESCRIPTION	DATE	APPROVED
A	REVISED PER NEW REQUIREMENTS	12/13/23	R.L.

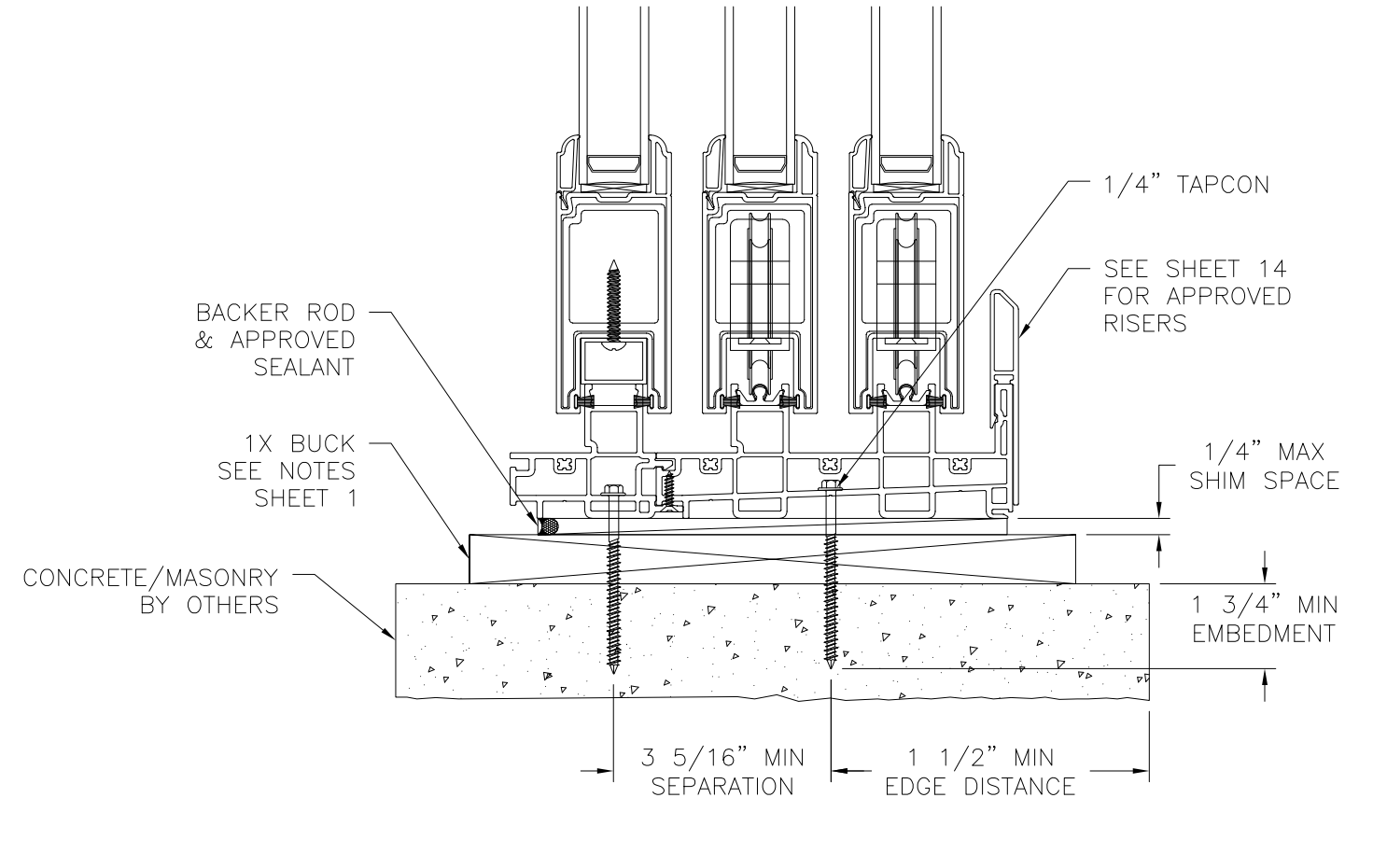
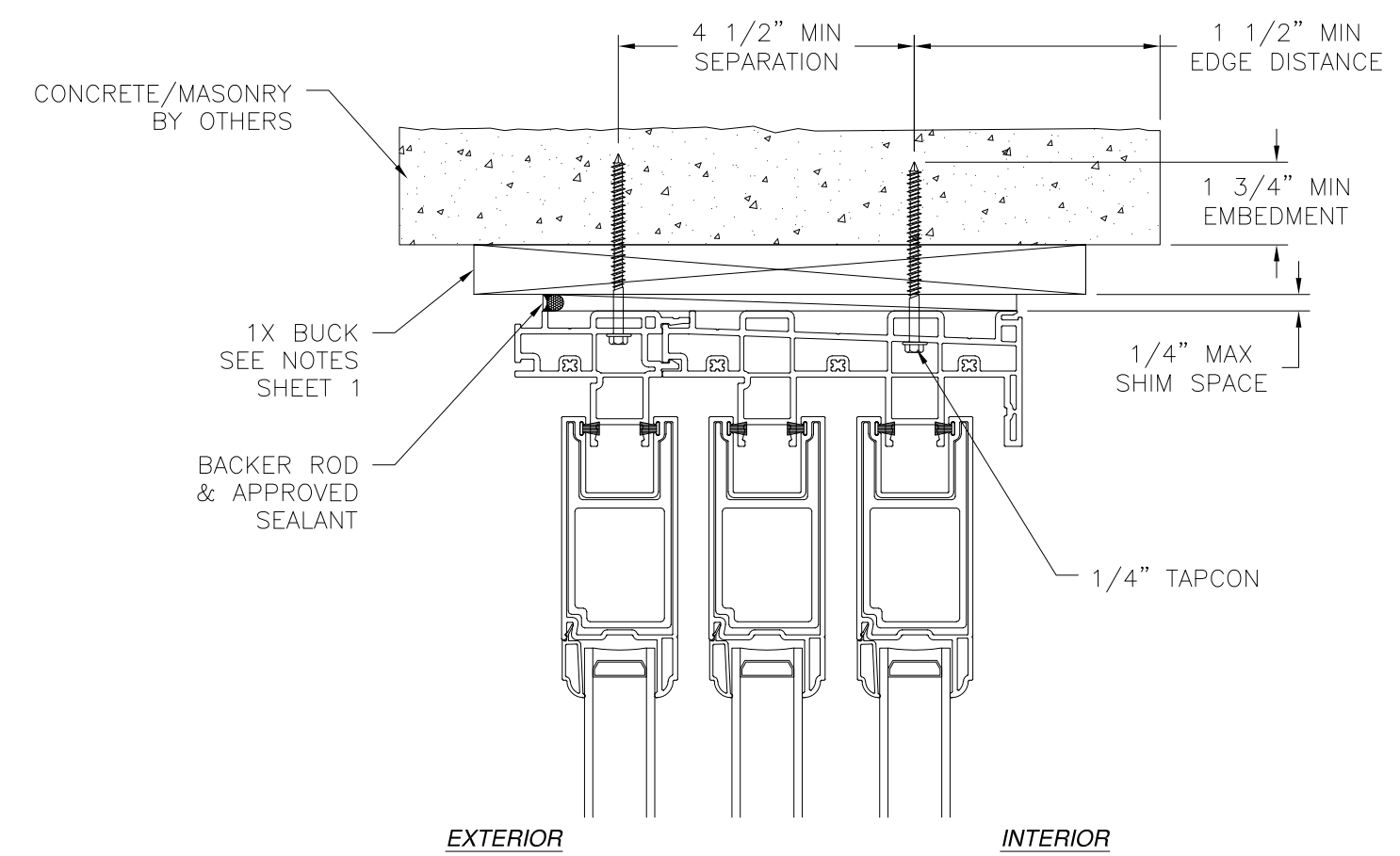

VERTICAL CROSS SECTION
CONCRETE/MASONRY INSTALLATION

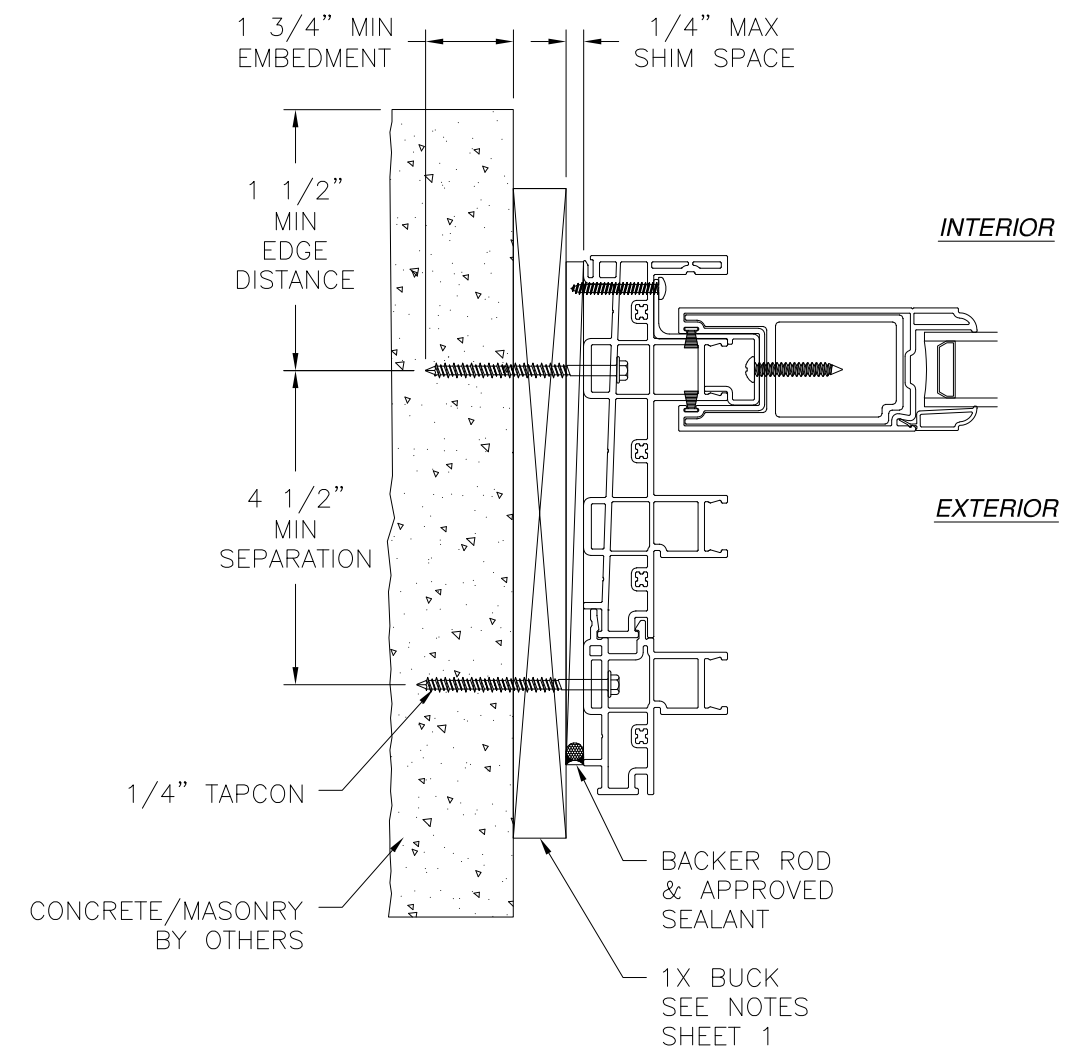

JAMB INSTALLATION DETAIL
CONCRETE/MASONRY INSTALLATION

- NOTES:**
1. INTERIOR AND EXTERIOR FINISHES, BY OTHERS, NOT SHOWN FOR CLARITY.
 2. PERIMETER AND JOINT SEALANT BY OTHERS TO BE DESIGNED IN ACCORDANCE WITH ASTM E2112

SIGNED: 01/03/2024

EASTERN ARCHITECTURAL SYSTEMS
16341 DOMESTIC AVENUE
FORT MYERS, FL 33192

SERIES 650 VINYL SGD
W/ & W/O POCKET CW-PG45 NON-IMPACT
3TRACK INSTALLATION DETAILS

DRAWN: R.L.	DWG NO. 08-03549	REV A
SCALE NTS	DATE 04/30/2020	SHEET 9 OF 14

L. ROBERTO LOMAS P.E.
208 7th Ave, INDIALANTIC, FL 32903
434-688-0609 rllomas@rlomaspe.com

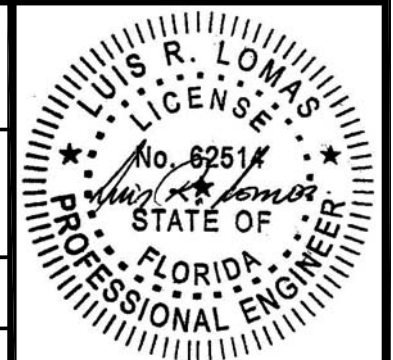

Luis R. Lomas P.E.
FL No.: 62514

REVISIONS			
REV	DESCRIPTION	DATE	APPROVED
A	REVISED PER NEW REQUIREMENTS	12/13/23	R.L.

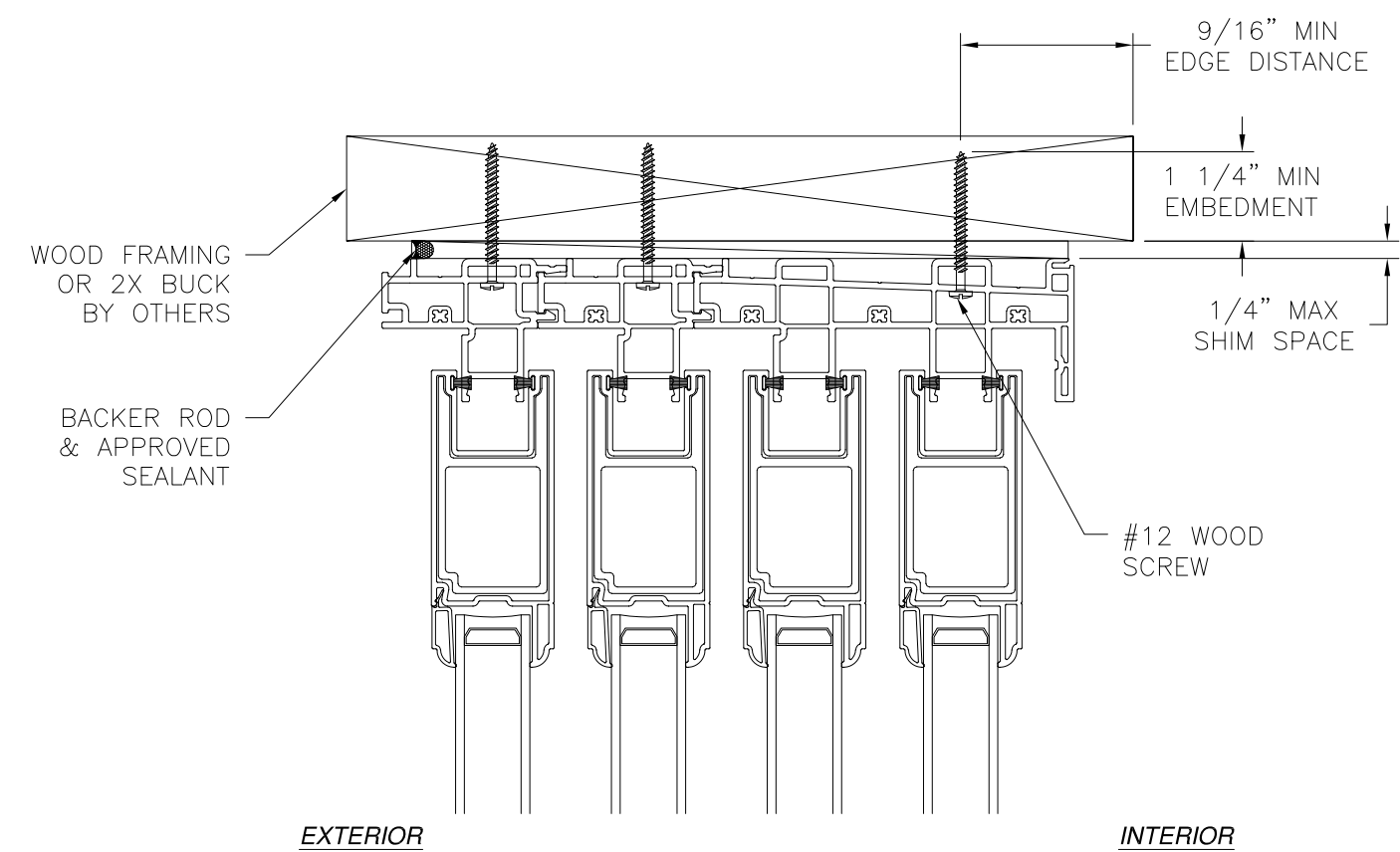

EXTERIOR INTERIOR

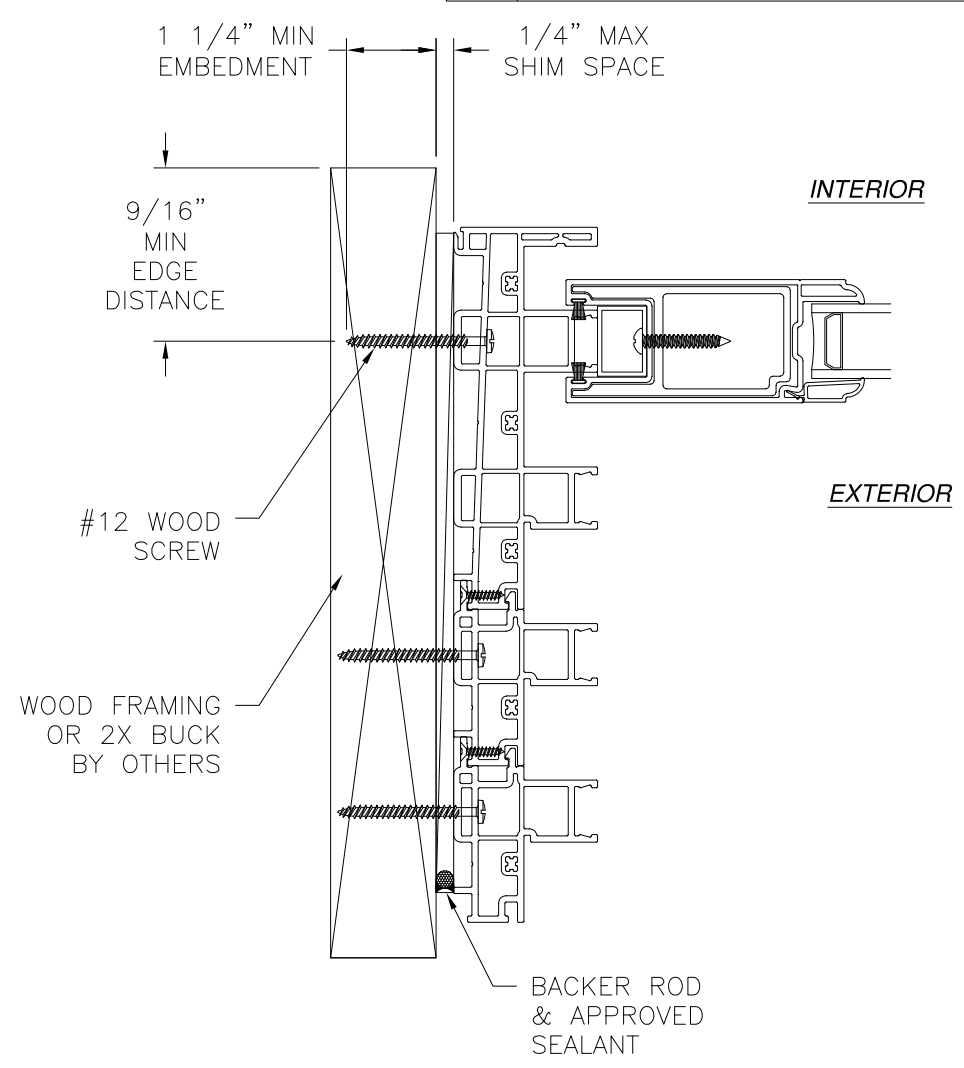

JAMB INSTALLATION DETAIL
WOOD FRAMING OR 2X BUCK INSTALLATION

- NOTES:**
1. INTERIOR AND EXTERIOR FINISHES, BY OTHERS, NOT SHOWN FOR CLARITY.
 2. PERIMETER AND JOINT SEALANT BY OTHERS TO BE DESIGNED IN ACCORDANCE WITH ASTM E2112

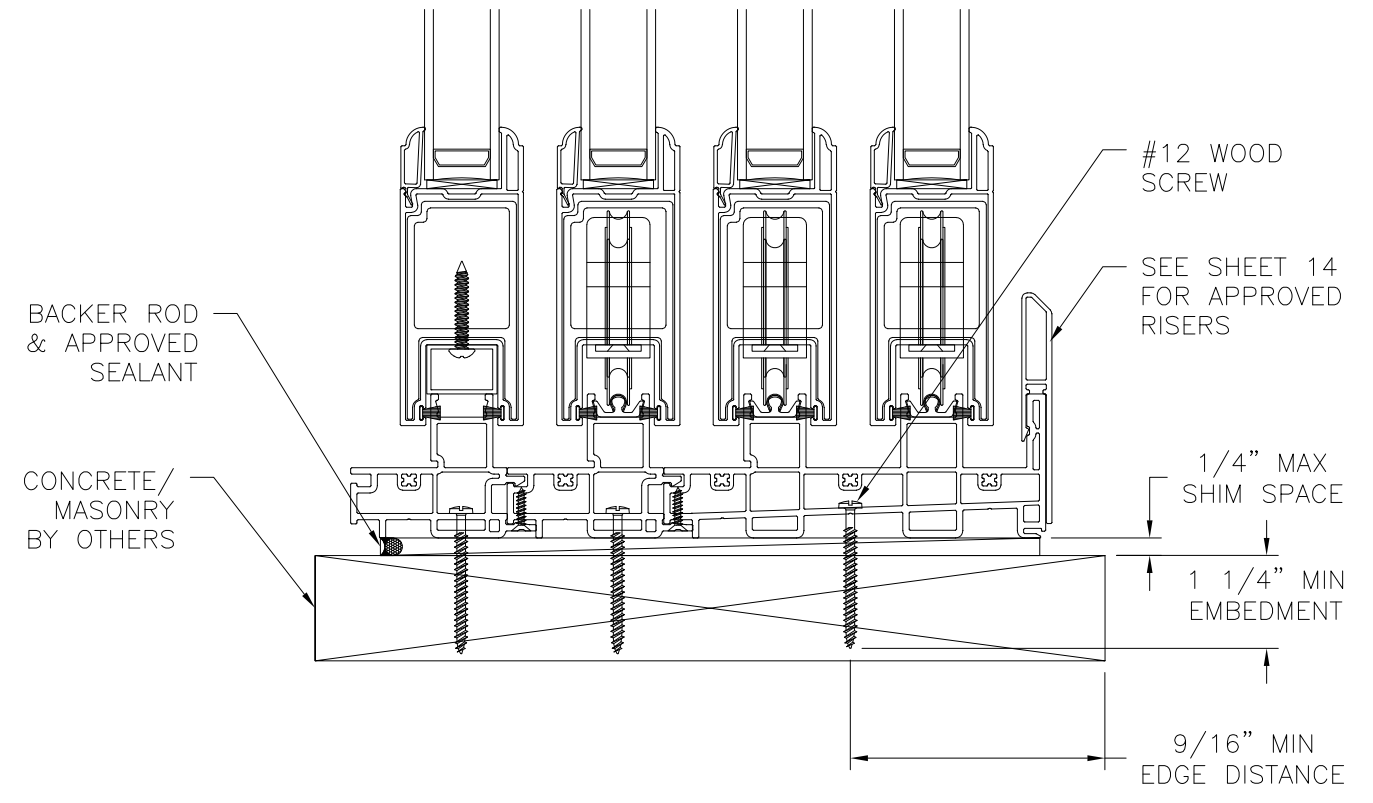

VERTICAL CROSS SECTION
WOOD FRAMING OR 2X BUCK INSTALLATION

EASTERN ARCHITECTURAL SYSTEMS
16341 DOMESTIC AVENUE
FORT MYERS, FL 33192

SERIES 650 VINYL SGD
W/ & W/O POCKET CW-PG45 NON-IMPACT
4TRACK INSTALLATION DETAILS

DRAWN: R.L.	DWG NO. 08-03549	REV A
SCALE NTS	DATE 04/30/2020	SHEET 10 OF 14

L. ROBERTO LOMAS P.E.
208 7th Ave, INDIALANTIC, FL 32903
434-688-0609 rllomas@lrlomaspe.com

SIGNED: 01/03/2024

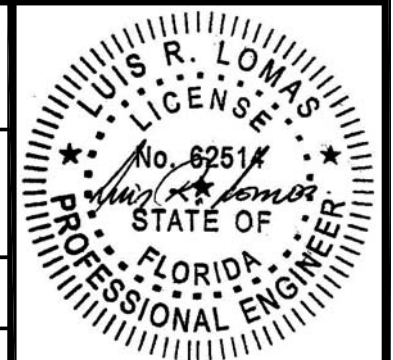

Luis R. Lomas P.E.
FL No.: 62514

REVISIONS			
REV	DESCRIPTION	DATE	APPROVED
A	REVISED PER NEW REQUIREMENTS	12/13/23	R.L.

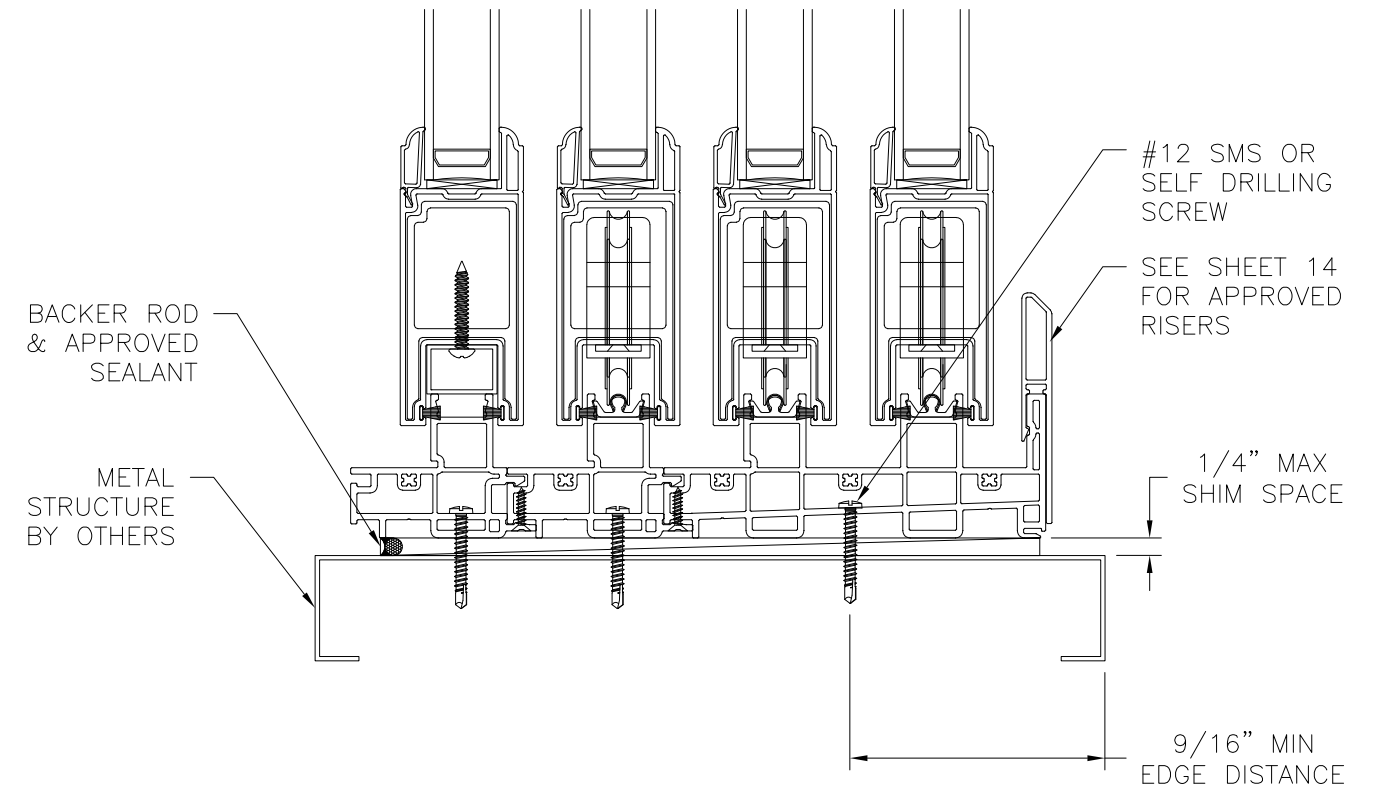
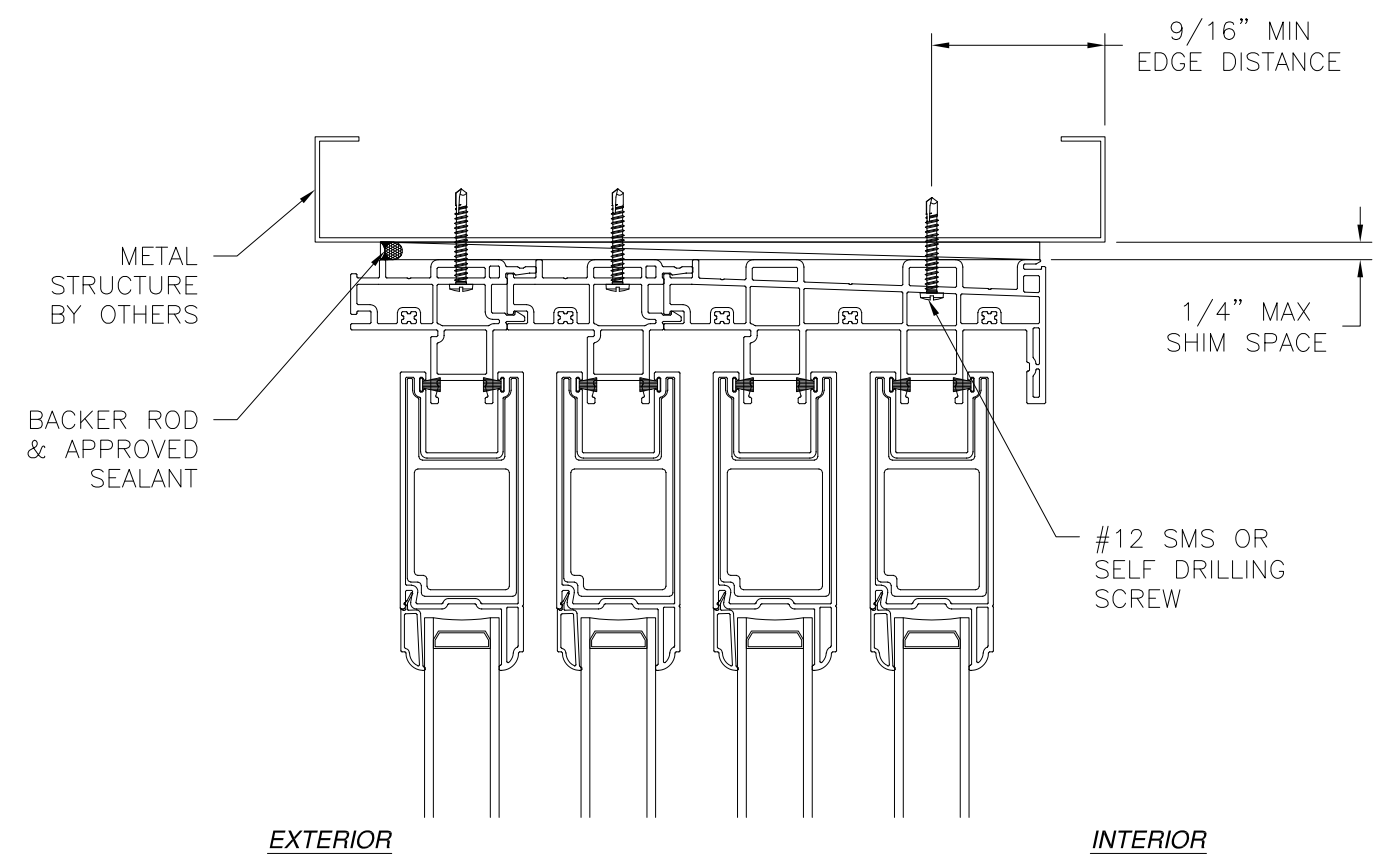

VERTICAL CROSS SECTION
METAL STRUCTURE INSTALLATION

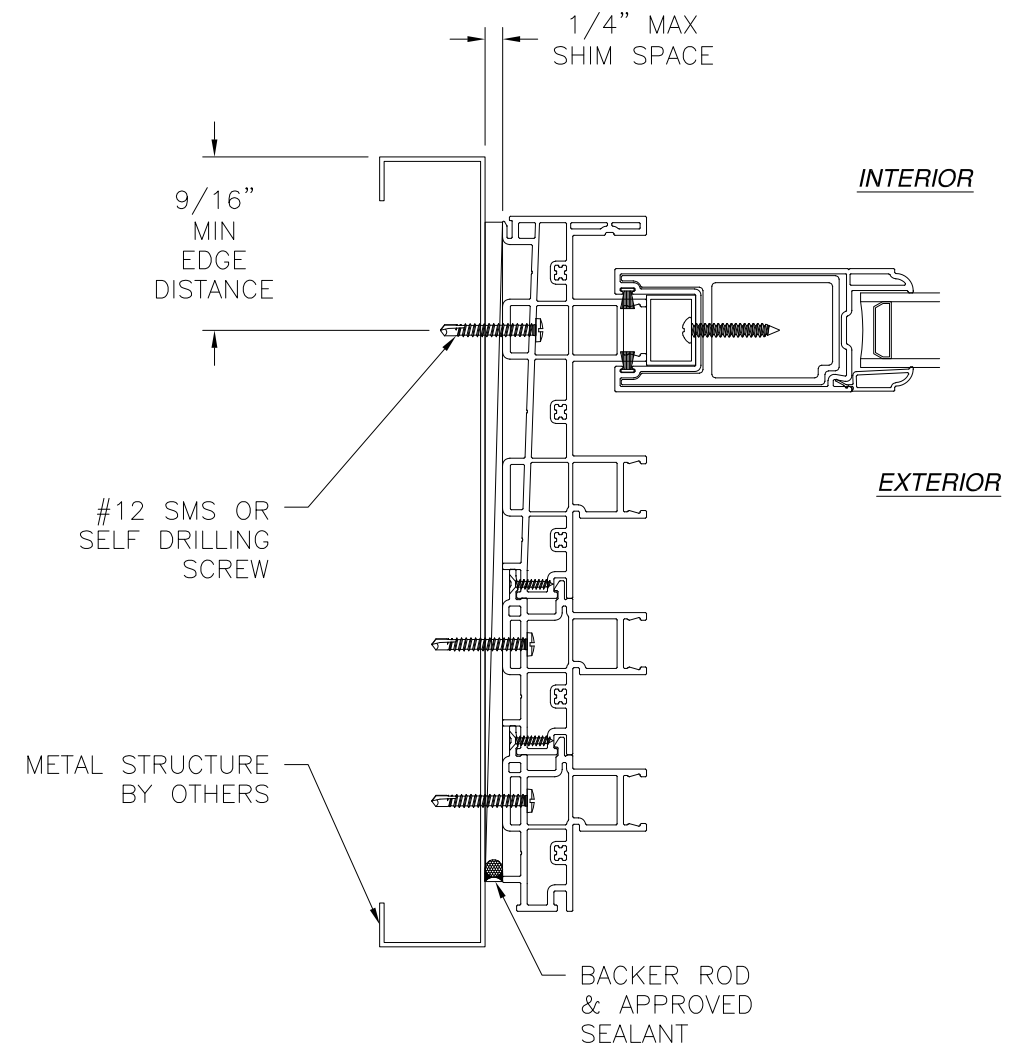

JAMB INSTALLATION DETAIL
METAL STRUCTURE INSTALLATION

- NOTES:**
1. INTERIOR AND EXTERIOR FINISHES, BY OTHERS, NOT SHOWN FOR CLARITY.
 2. PERIMETER AND JOINT SEALANT BY OTHERS TO BE DESIGNED IN ACCORDANCE WITH ASTM E2112

SIGNED: 01/03/2024

EASTERN ARCHITECTURAL SYSTEMS
16341 DOMESTIC AVENUE
FORT MYERS, FL 33192

SERIES 650 VINYL SGD
W/ & W/O POCKET CW-PG45 NON-IMPACT
4TRACK INSTALLATION DETAILS

DRAWN: R.L.	DWG NO. 08-03549	REV A
SCALE NTS	DATE 04/30/2020	SHEET 11 OF 14

L. ROBERTO LOMAS P.E.
208 7th Ave, INDIALANTIC, FL 32903
434-688-0609 rllomas@rlomaspe.com

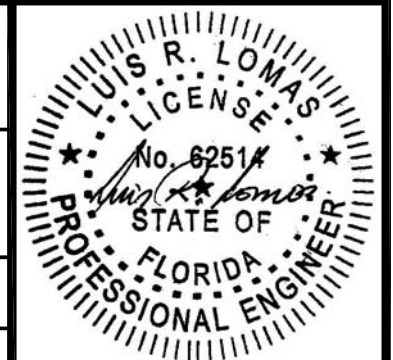

Luis R. Lomas P.E.
FL No.: 62514

REVISIONS			
REV	DESCRIPTION	DATE	APPROVED
A	REVISED PER NEW REQUIREMENTS	12/13/23	R.L.

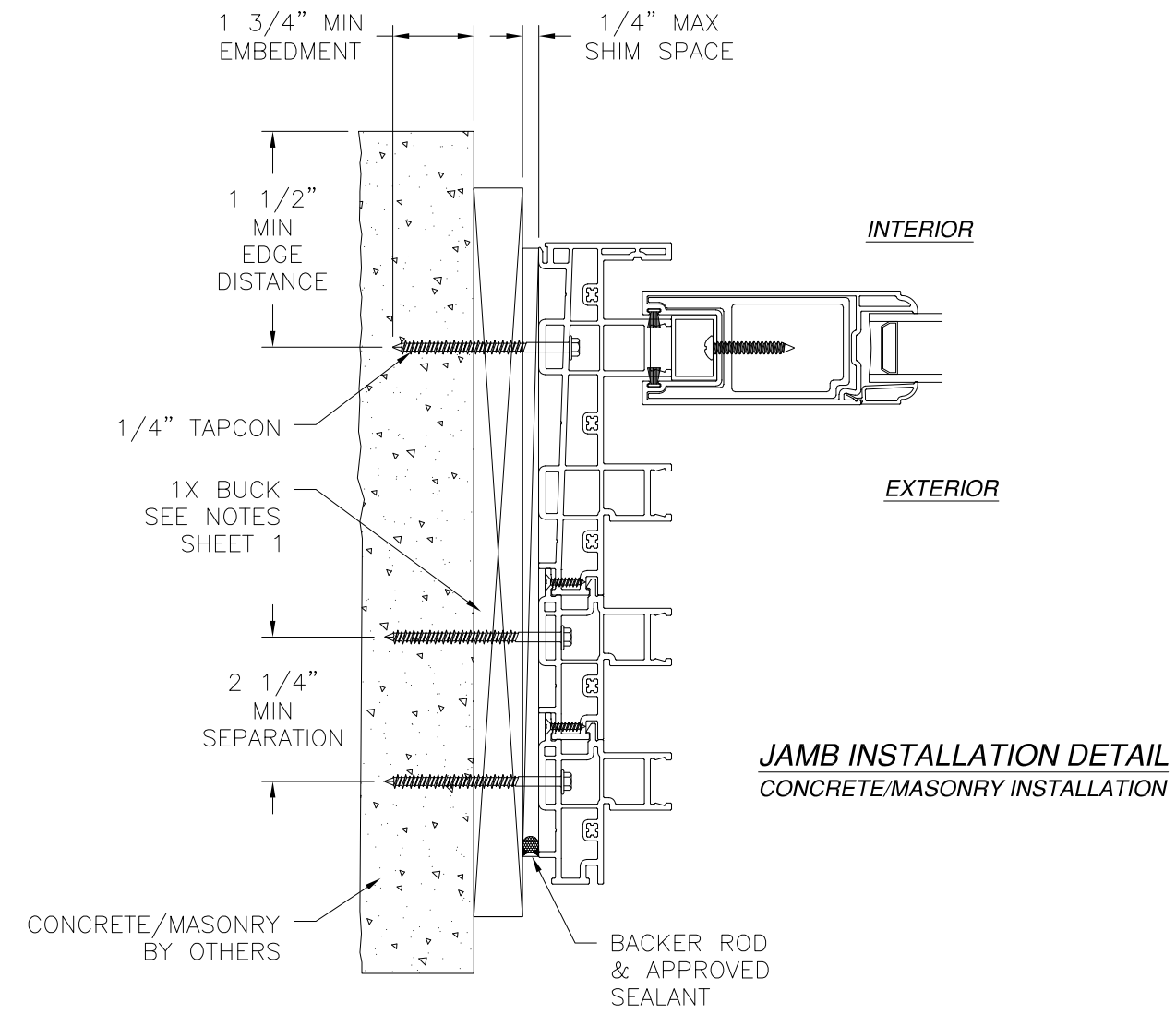
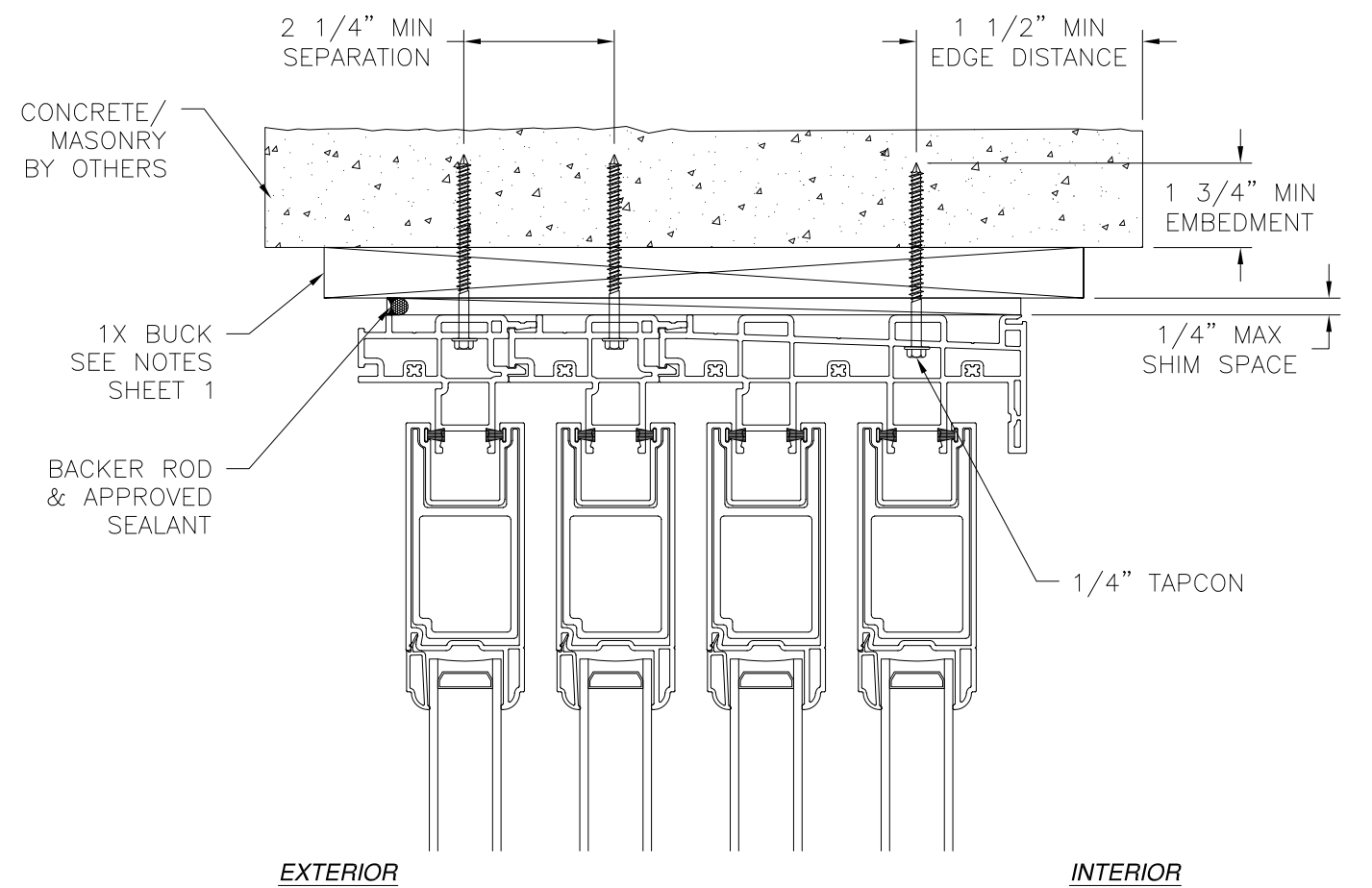

- NOTES:**
1. INTERIOR AND EXTERIOR FINISHES, BY OTHERS, NOT SHOWN FOR CLARITY.
 2. PERIMETER AND JOINT SEALANT BY OTHERS TO BE DESIGNED IN ACCORDANCE WITH ASTM E2112

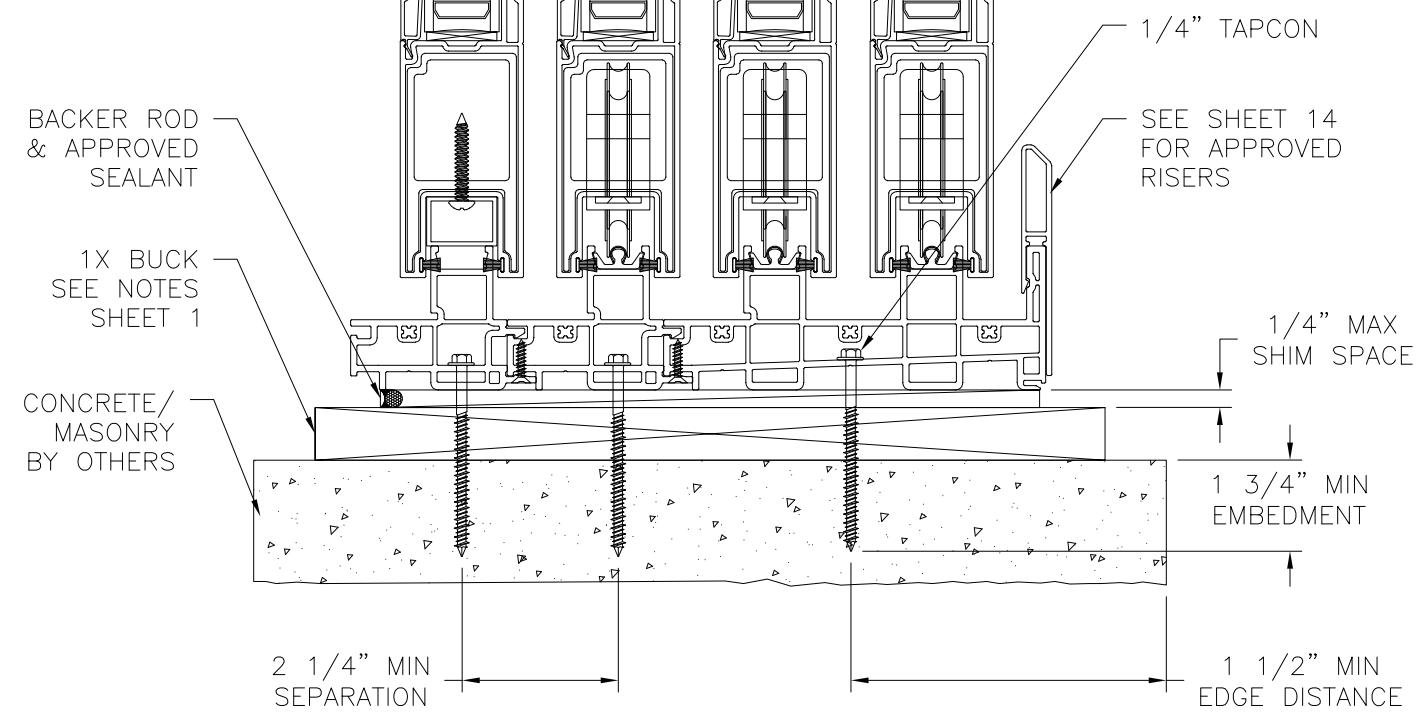

**VERTICAL CROSS SECTION
CONCRETE/MASONRY INSTALLATION**

**JAMB INSTALLATION DETAIL
CONCRETE/MASONRY INSTALLATION**

SIGNED: 01/03/2024

EASTERN ARCHITECTURAL SYSTEMS
16341 DOMESTIC AVENUE
FORT MYERS, FL 33192

SERIES 650 VINYL SGD
W/ & W/O POCKET CW-PG45 NON-IMPACT
4TRACK INSTALLATION DETAILS

DRAWN: R.L.	DWG NO. 08-03549	REV A
SCALE NTS	DATE 04/30/2020	SHEET 12 OF 14

L. ROBERTO LOMAS P.E.
208 7th Ave, INDIALANTIC, FL 32903
434-688-0609 rllomas@rlomaspe.com

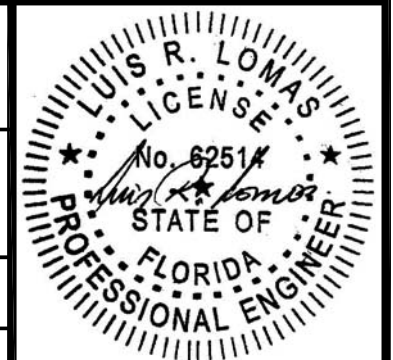

Luis R. Lomas P.E.
FL No.: 62514

REVISIONS			
REV	DESCRIPTION	DATE	APPROVED
A	REVISED PER NEW REQUIREMENTS	12/13/23	R.L.

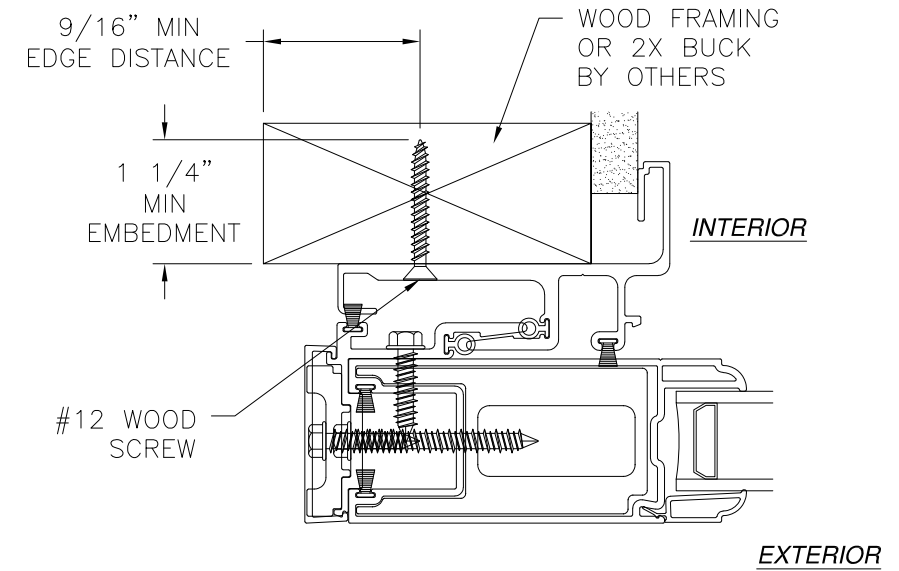

P-HOOK CROSS SECTION
WOOD FRAMING OR 2X BUCK INSTALLATION

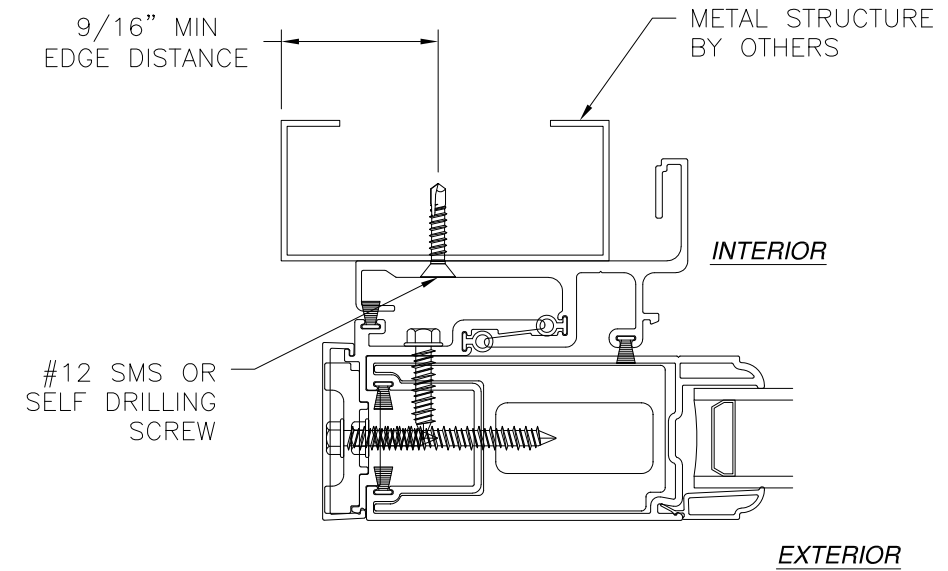

P-HOOK CROSS SECTION
METAL STRUCTURE INSTALLATION

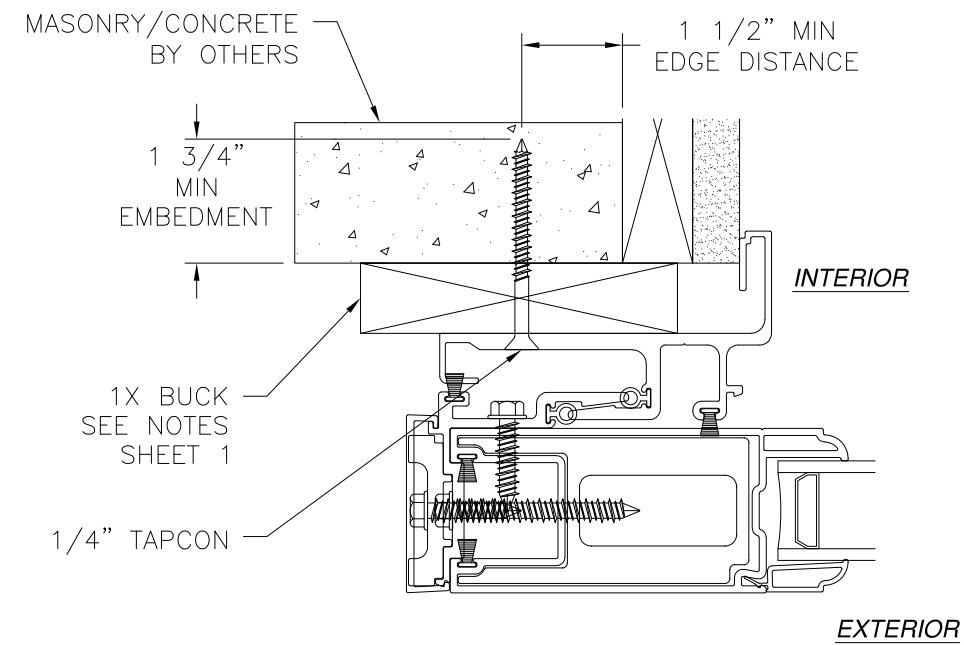

P-HOOK CROSS SECTION
CONCRETE/MASONRY INSTALLATION

EASTERN ARCHITECTURAL SYSTEMS
16341 DOMESTIC AVENUE
FORT MYERS, FL 33192

SERIES 650 VINYL SGD
W/ & W/O POCKET CW-PG45 NON-IMPACT
P-HOOK INSTALLATION DETAILS

DRAWN: R.L.	DWG NO. 08-03549	REV A
SCALE NTS	DATE 04/30/2020	SHEET 13 OF 14

L. ROBERTO LOMAS P.E.
208 7th Ave, INDIALANTIC, FL 32903
434-688-0609 rllomas@lrlomaspe.com

SIGNED: 01/03/2024

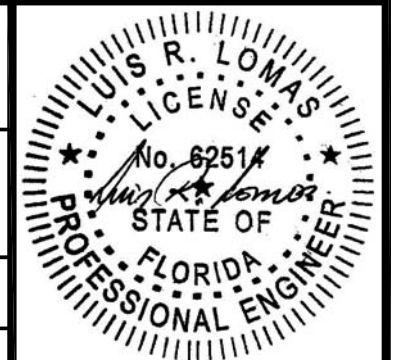

Luis R. Lomas P.E.
FL No.: 62514

REVISIONS			
REV	DESCRIPTION	DATE	APPROVED
A	REVISED PER NEW REQUIREMENTS	12/13/23	R.L.

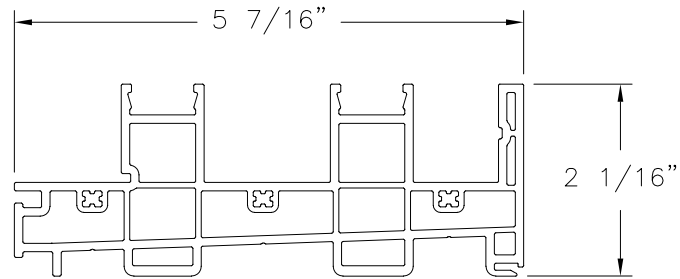

FRAME (10001160)
PVC (.110" THICK)

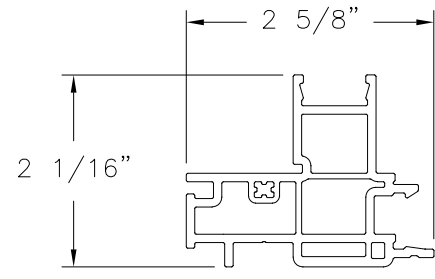

FRAME ADPT. (10001165)
PVC (.110" THICK)

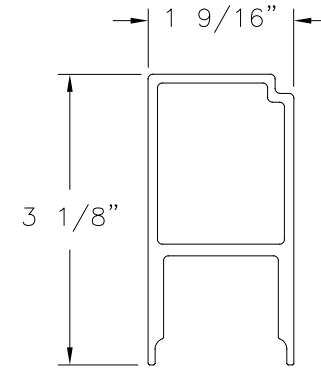

TOP/BOTTOM AND LOCK STILE REINFORCEMENT (10300231)
ALUMINUM 6063-T5 (.165" THICK)

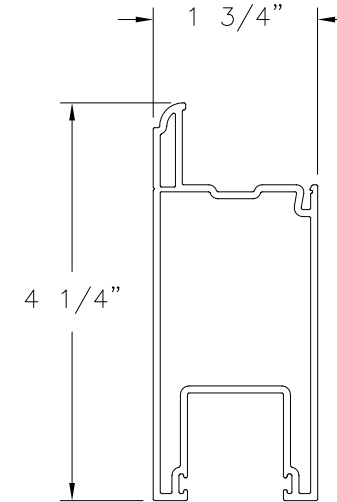

SASH FRAME
PVC (.075" THICK)

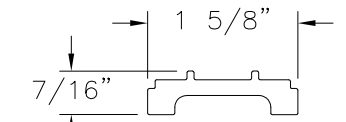

CLIP (10300264)
ALUMINUM 6005-T5 (.1675" THICK)

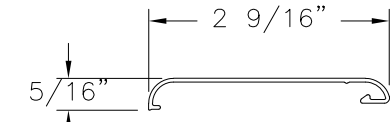

ASTRAGAL COVER (10001100)
PVC (.040" THICK)

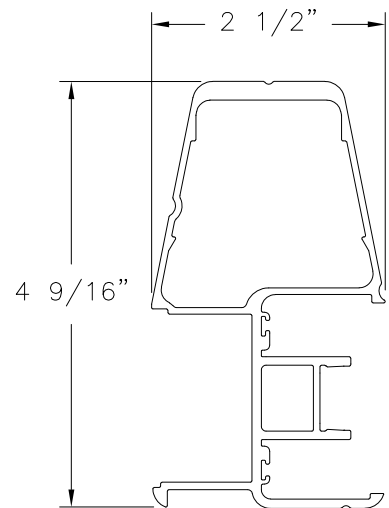

ASTRAGAL (10300233)
ALUMINUM 6063-T5 (.100" THICK)

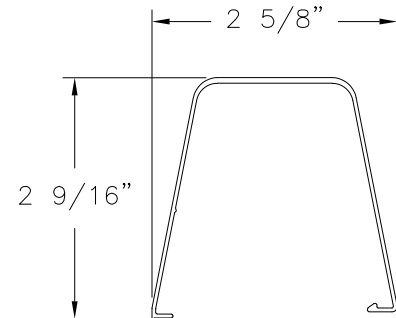

ASTRAGAL COVER (10001101)
PVC (.060" THICK)

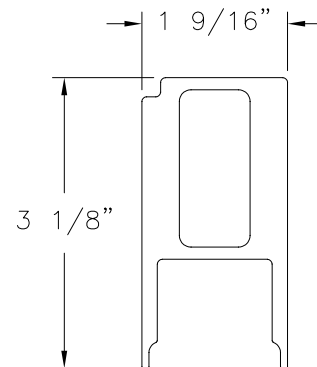

INTERLOCK STILE REINFORCEMENT (10300309)
ALUMINUM 6005-T5 (.165" THICK)

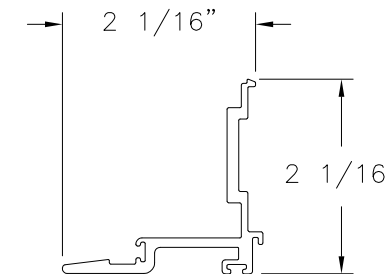

INTERLOCK (10300237)
ALUMINUM 6005-T5 (.100" THICK)

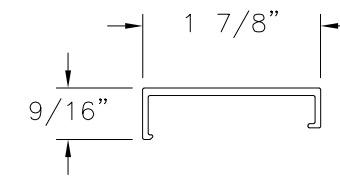

INTERLOCK COVER
PVC (.080" THICK)

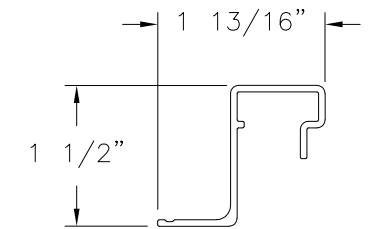

JAMB SPACER (10300300)
ALUMINUM 6063-T5 (.070" THICK)

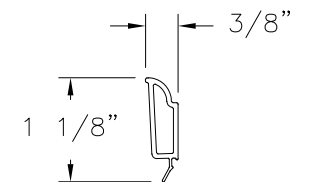

GLAZING BEAD (10001175)
PVC (.075" THICK)

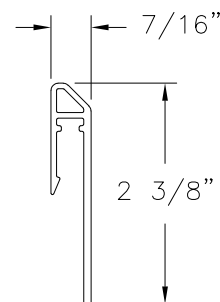

SILL RISER (10300323)
ALUMINUM 6063-T5 (.078" THICK)

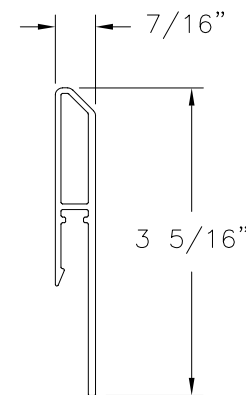

SILL RISER (10300240)
ALUMINUM 6063-T5 (.078" THICK)

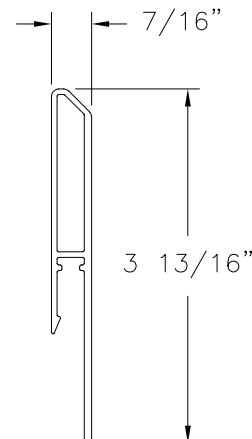

SILL RISER (10300241)
ALUMINUM 6063-T5 (.078" THICK)

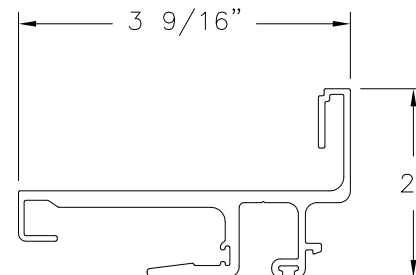

HOOK
ALUMINUM 6063-T5 (.1755" THICK)

EASTERN ARCHITECTURAL SYSTEMS
16341 DOMESTIC AVENUE
FORT MYERS, FL 33192

SERIES 650 VINYL SGD
W/ & W/O POCKET CW-PG45 NON-IMPACT
COMPONENTS

DRAWN: R.L.	DWG NO. 08-03549	REV A
SCALE NTS	DATE 04/30/2020	SHEET 14 OF 14

L. ROBERTO LOMAS P.E.
208 7th Ave, INDIALANTIC, FL 32903
434-688-0609 rllomas@rlomaspe.com

SIGNED: 01/03/2024

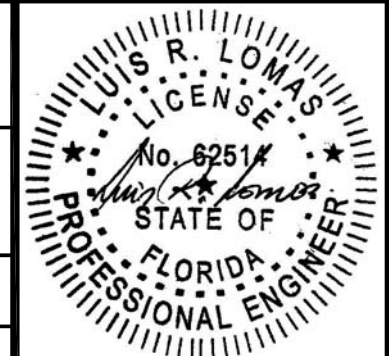

Luis R. Lomas P.E.
FL No.: 62514