

GENERAL NOTES:

1. ALLOWABLE DESIGN PRESSURE: +/- 65 PSF
2. THIS PRODUCT HAS BEEN DESIGNED AND TESTED TO TAS 201, 202, & 203 PROTOCOLS IN ACCORDANCE WITH THE REQUIREMENTS OF THE CURRENT EDITION OF THE FLORIDA BUILDING CODE (FBC), INCLUDING THE HVHZ PROVISIONS.
3. THIS PRODUCT AS SHOWN HEREIN IS LARGE AND SMALL MISSILE IMPACT RESISTANT, SHUTTERS ARE NOT REQUIRED.
4. WOOD OR MASONRY OPENINGS, BUCKS, AND BUCK FASTENERS, BY OTHERS, SHALL BE PROPERLY DESIGNED AND INSTALLED TO TRANSFER LOADS TO THE STRUCTURE.
5. ANCHOR TYPE, SIZE, SPACING, AND EMBEDMENT SHALL BE AS INDICATED IN THIS APPROVAL. ANCHOR EMBEDMENT TO SUBSTRATE SHALL BE BEYOND WALL DRESSING OR STUCCO.
6. ALL FASTENERS PENETRATING INTO PRESSURE TREATED WOOD SHALL BE CAPABLE OF PREVENTING CORROSION DUE TO REACTION WITH PRESSURE TREATMENT CHEMICALS.
7. DISSIMILAR MATERIALS THAT COME INTO CONTACT SHALL BE PROTECTED TO PREVENT GALVANIC REACTIONS.
8. NO STRESS INCREASES WERE USED IN THE DESIGN OR ANALYSIS OF THIS PRODUCT. A WIND LOAD DURATION FACTOR $C_d = 1.6$ WAS USED FOR THE ANALYSIS OF WOOD SCREWS ONLY.

CORNER CONSTRUCTION:

9. WINDOW FRAME CORNERS ARE MITERED AND CRIMPED OVER 0687853.00 AND 0687952.00 CORNER KEYS, AND SECURED WITH REYNASEAL DUO.
10. WINDOW SASH CORNERS ARE MITERED AND CRIMPED OVER (2) 0687771.00 CORNER KEYS, SECURED WITH REYNASEAL DUO, AND SEALED WITH REYNAPROTECTOR.

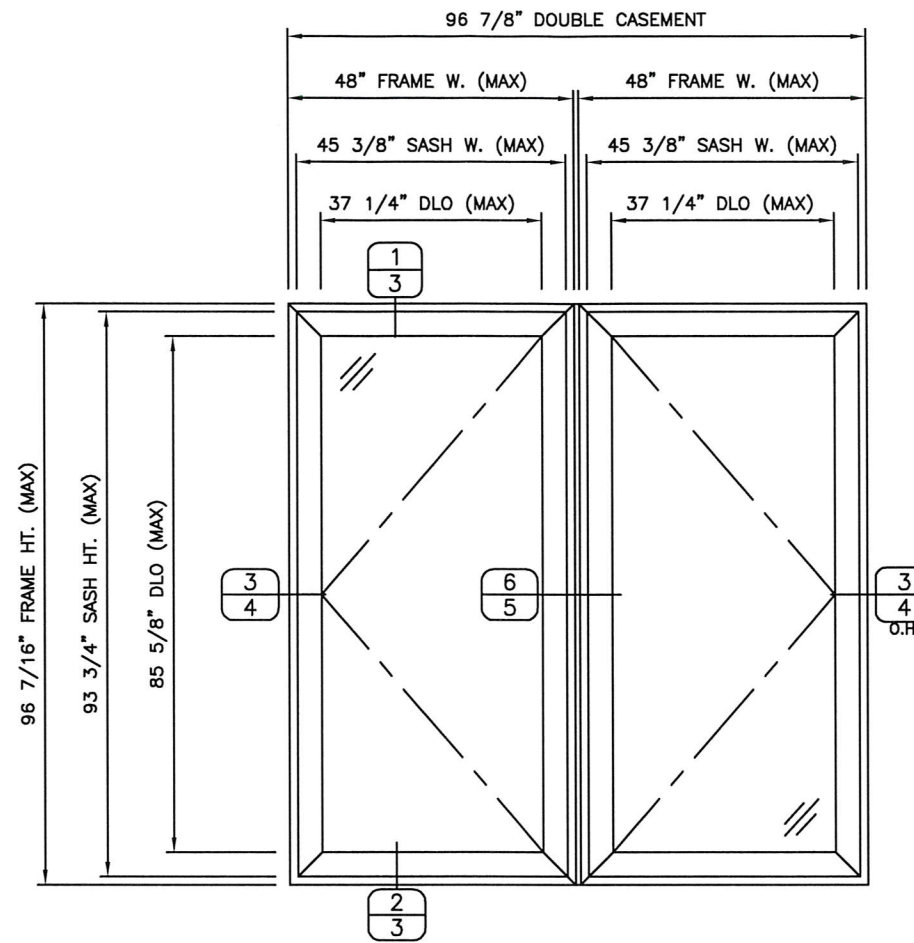

**DOUBLE CASEMENT WINDOW
(EXTERIOR VIEW)**

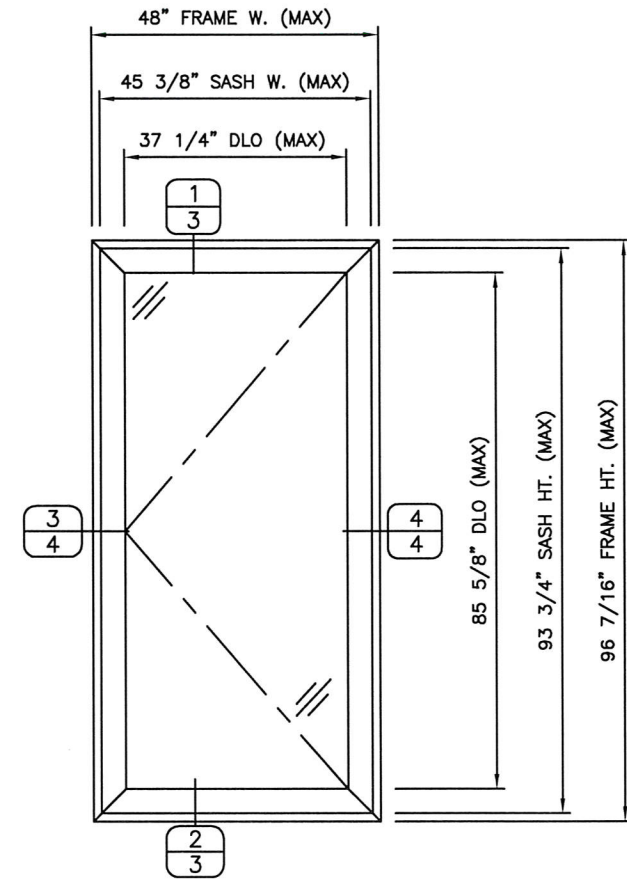

**CASEMENT WINDOW
(EXTERIOR VIEW)**

DESIGN PRESSURE
+/- 65 PSF

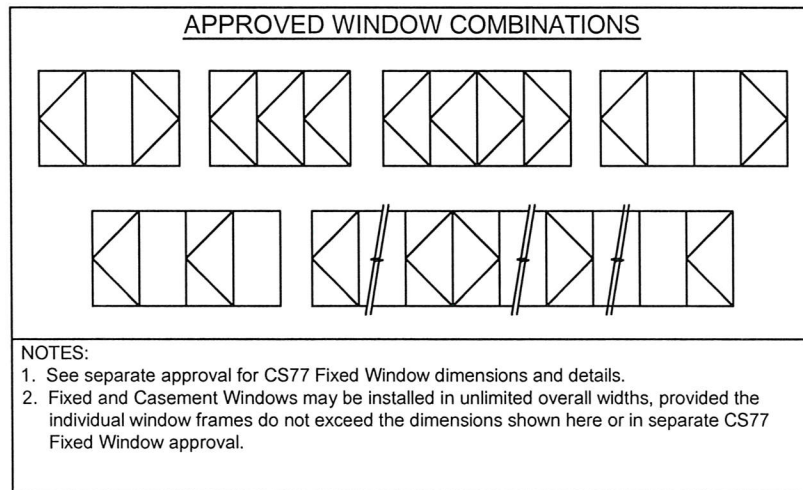

OPTIONAL CS77 FIXED WINDOWS
PER SEPARATE PRODUCT APPROVAL.

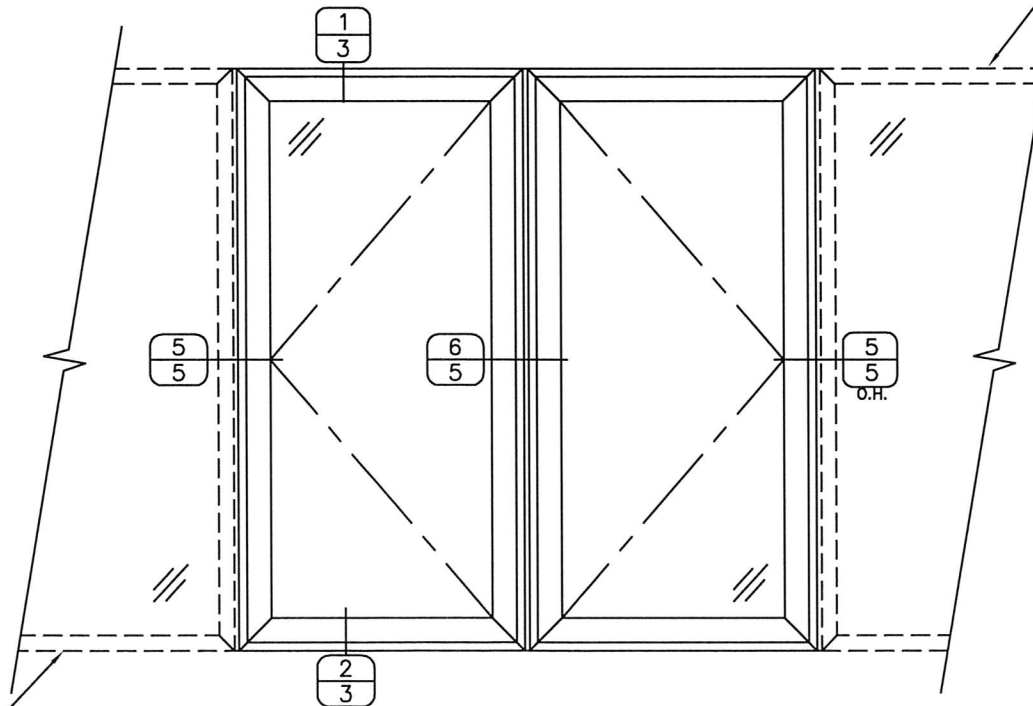

**DOUBLE CASEMENT WINDOW
WITH OPTIONAL FIXED SIDELITES
(EXTERIOR VIEW)**

OPTIONAL CS77 FIXED WINDOWS
PER SEPARATE PRODUCT APPROVAL.

FOR FASTENER AND HARDWARE
LOCATIONS SEE SHEET 2/7.

DATE: 7/30/18

NO.	REVISION DESCRIPTION	DATE

CS77 SERIES CASEMENT WINDOW

REYNAERS, INC.

Ph: (480) 272-9688
www.reynaers.com

21430 NORTH 15TH LANE, SUITE 111
PHOENIX, AZ 85027

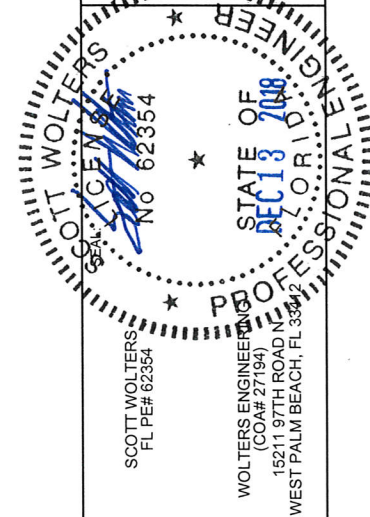

DRAWING NO.
CS77CASELMI

SHEET NO.
1 of 7

FASTENER AND HARDWARE LOCATIONS

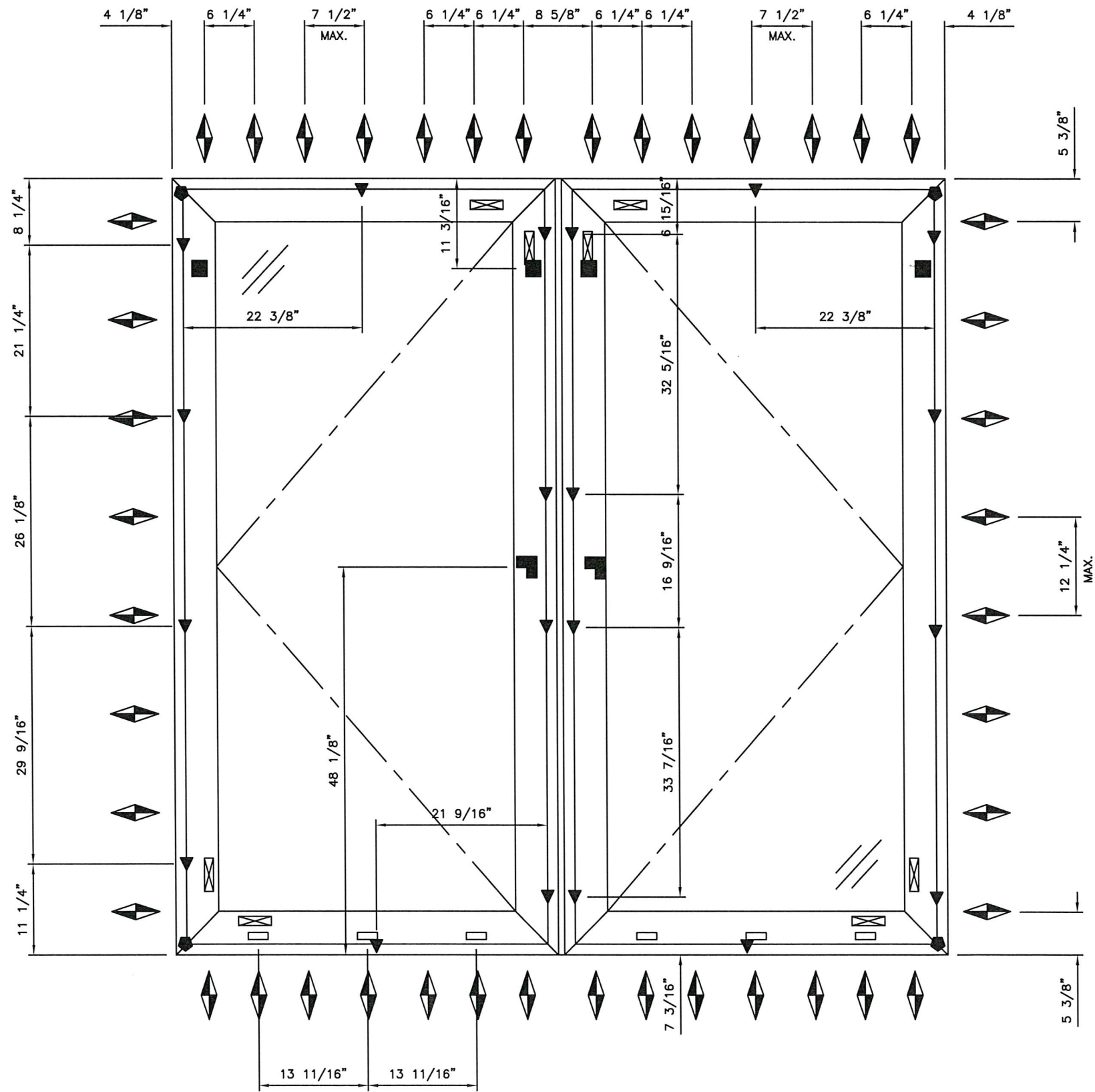

SYMBOL LEGEND:

- ◆ STRAP ANCHOR 0566016 WITH (2) FASTENERS PER FRAME ANCHOR CHART ON SHEET 6/7.
- ▼ SOBINCO LOCKING HARDWARE, (10) PER VENT (FOR MORE INFO SEE BILL OF MATERIALS ON SHEET 7/7).
- ◆ SOBINCO HINGES 060.9012 (LEFT) OR 060.9013 (RIGHT), (2) PER VENT.
- SOBINCO LOCK HANDLE 060.6543.
- WEEP SLOT AND COVER 069.6831.04, (3) PER VENT.
- VENT DECOMPRESSION (3/16" DIA.)
- ⊠ GLASS SETTING BLOCK OR CORNER BLOCK.

DATE: 7/30/18

DATE

REVISION DESCRIPTION

NO.

CS77 SERIES CASEMENT WINDOW

REYNAERS, INC.
 21430 NORTH 15TH LANE, SUITE 111
 PHOENIX, AZ 85027
 Ph: (480) 272-9688
 www.reynaers.com

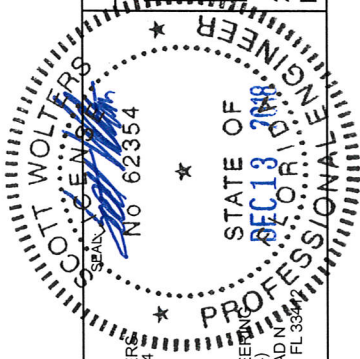

SCOTT WALTERS
 FL PE# 62354
 WALTERS ENGINEERING
 (COA# 27194)
 15211 97TH ROAD N
 WEST PALM BEACH, FL 33411

DRAWING NO. CS77CASELMI

SHEET NO. 2 of 7

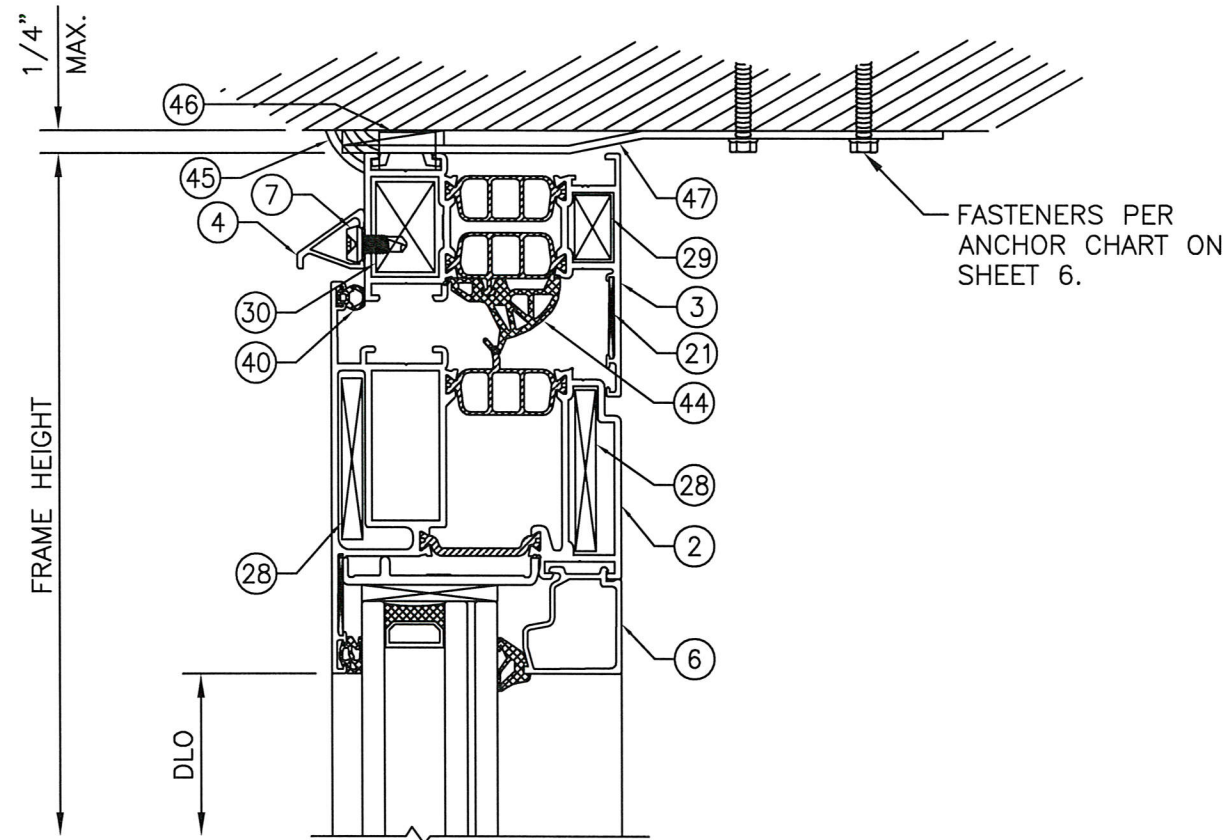

EXTERIOR

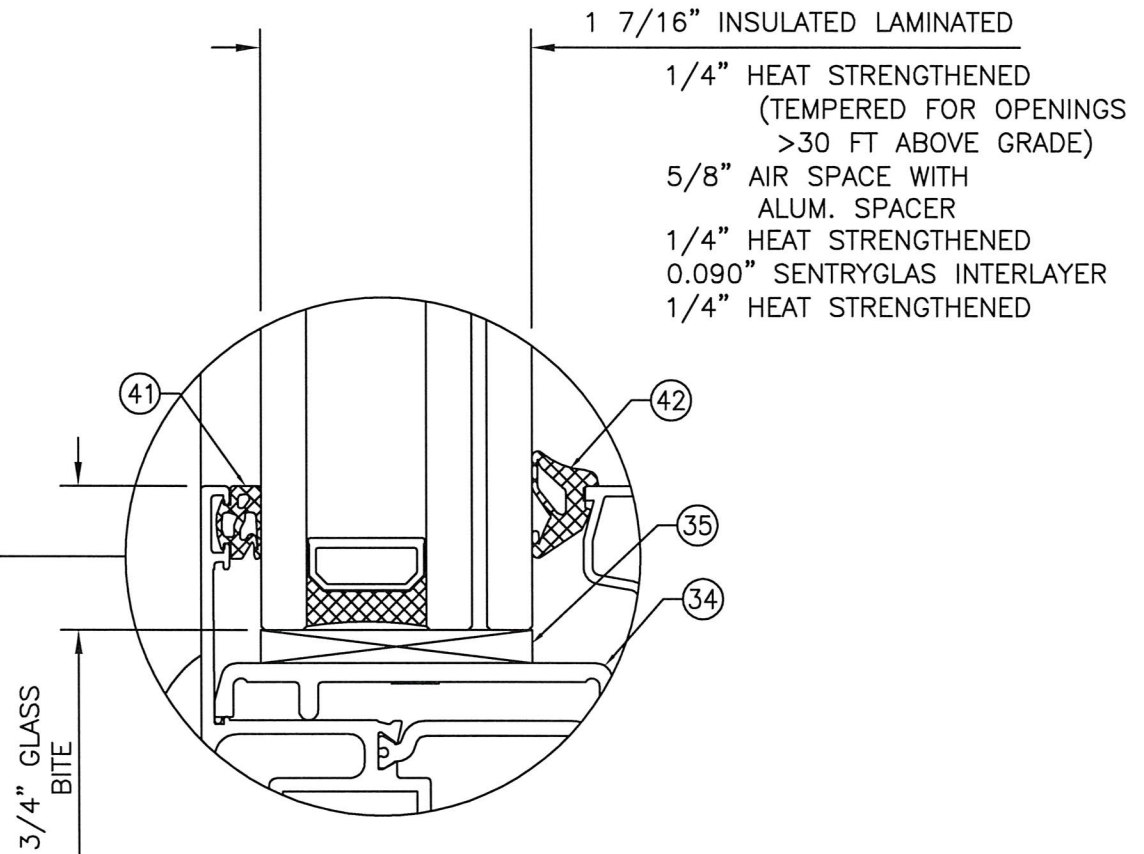
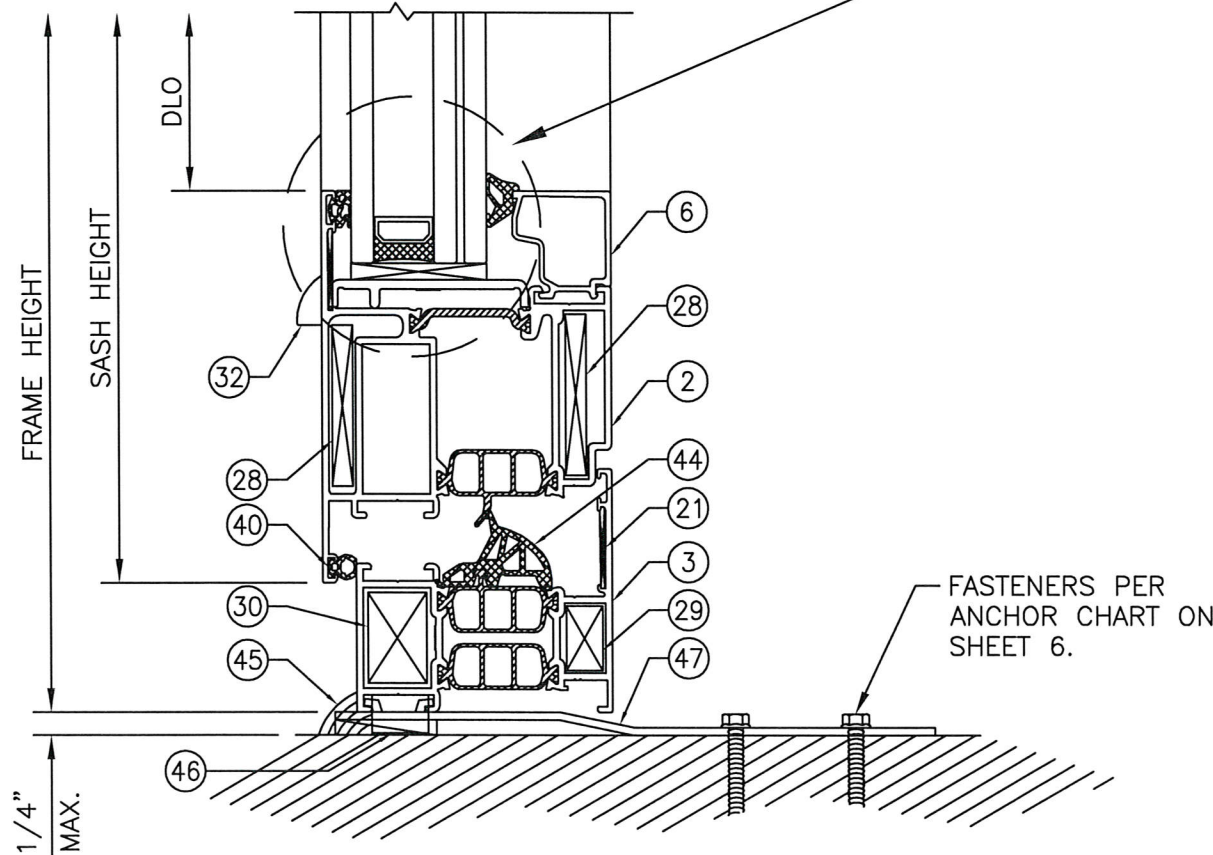

GLAZING DETAIL

1
3

2
3

DATE:	7/30/18
REVISION DESCRIPTION	
NO.	
CS77 SERIES CASEMENT WINDOW	
REYNAERS, INC.	
21430 NORTH 15TH LANE, SUITE 111 PHOENIX, AZ 85027	
Ph: (480) 272-9688 www.reynaers.com	
DRAWING NO.	CS77CASELMI
SHEET NO.	3 of 7

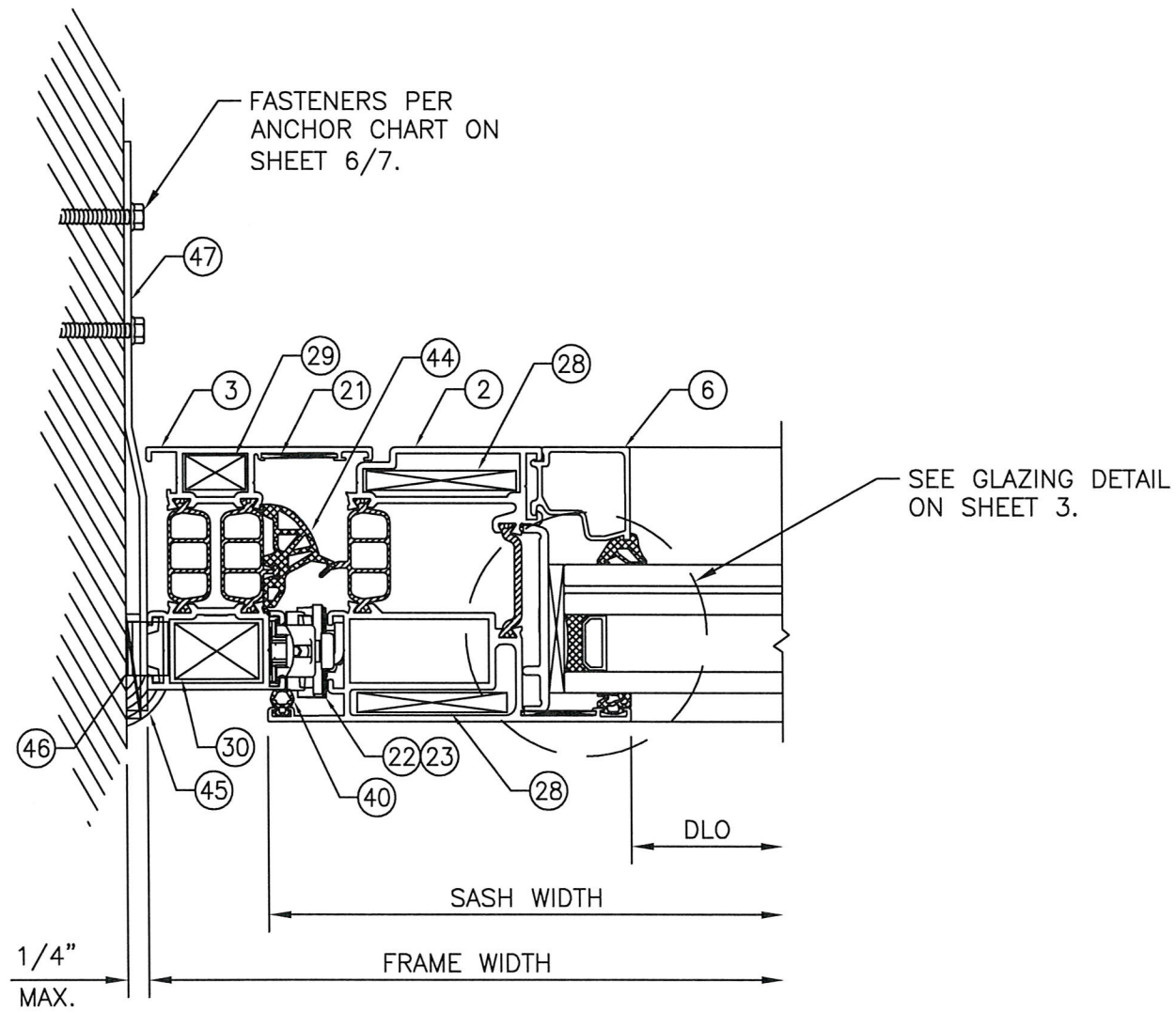

EXTERIOR

3
4

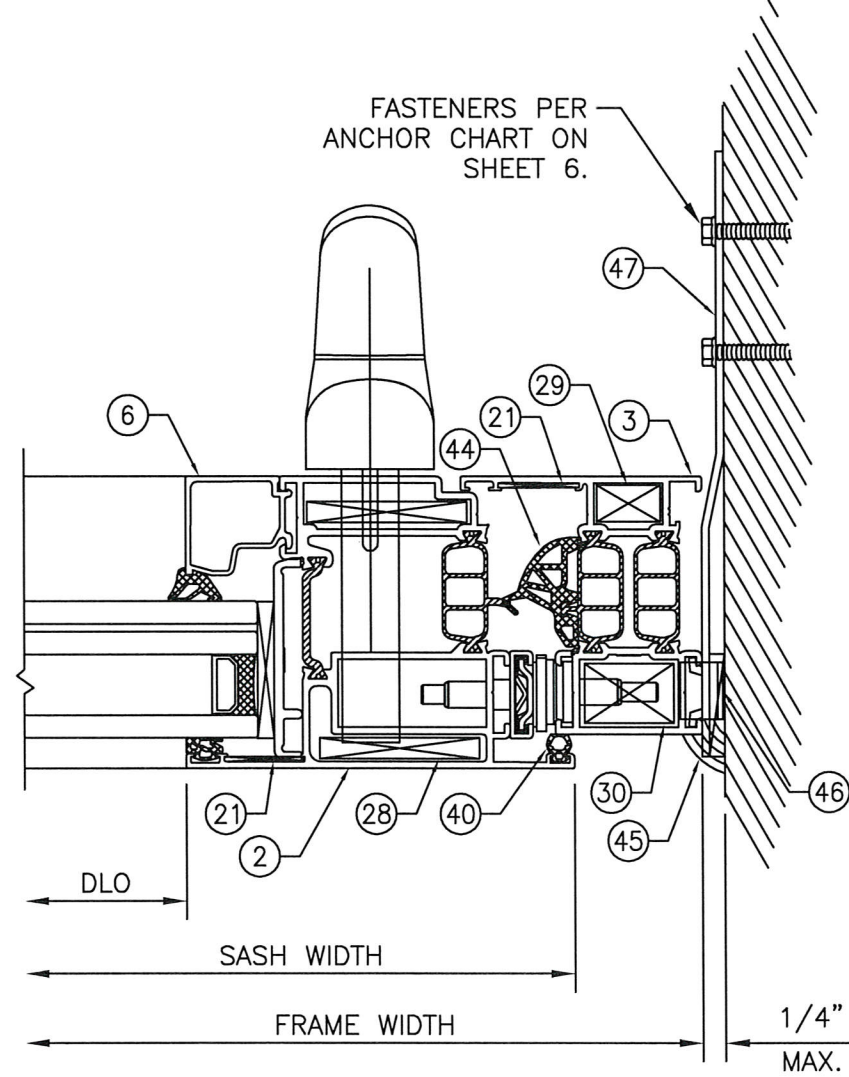

4
4

NO.	REVISION DESCRIPTION	DATE
		7/30/18

CS77 SERIES CASEMENT WINDOW

REYNAERS, INC.

21430 NORTH 15TH LANE, SUITE 111
PHOENIX, AZ 85027
Ph: (480) 272-9688
www.reynaers.com

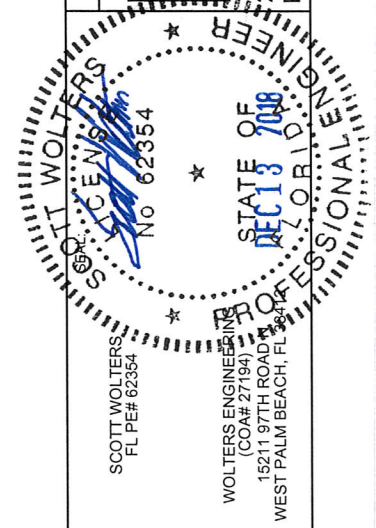

DRAWING NO.
CS77CASELMI

SHEET NO.
4 of 7

DATE:	7/30/18
DATE	
REVISION DESCRIPTION	
NO.	

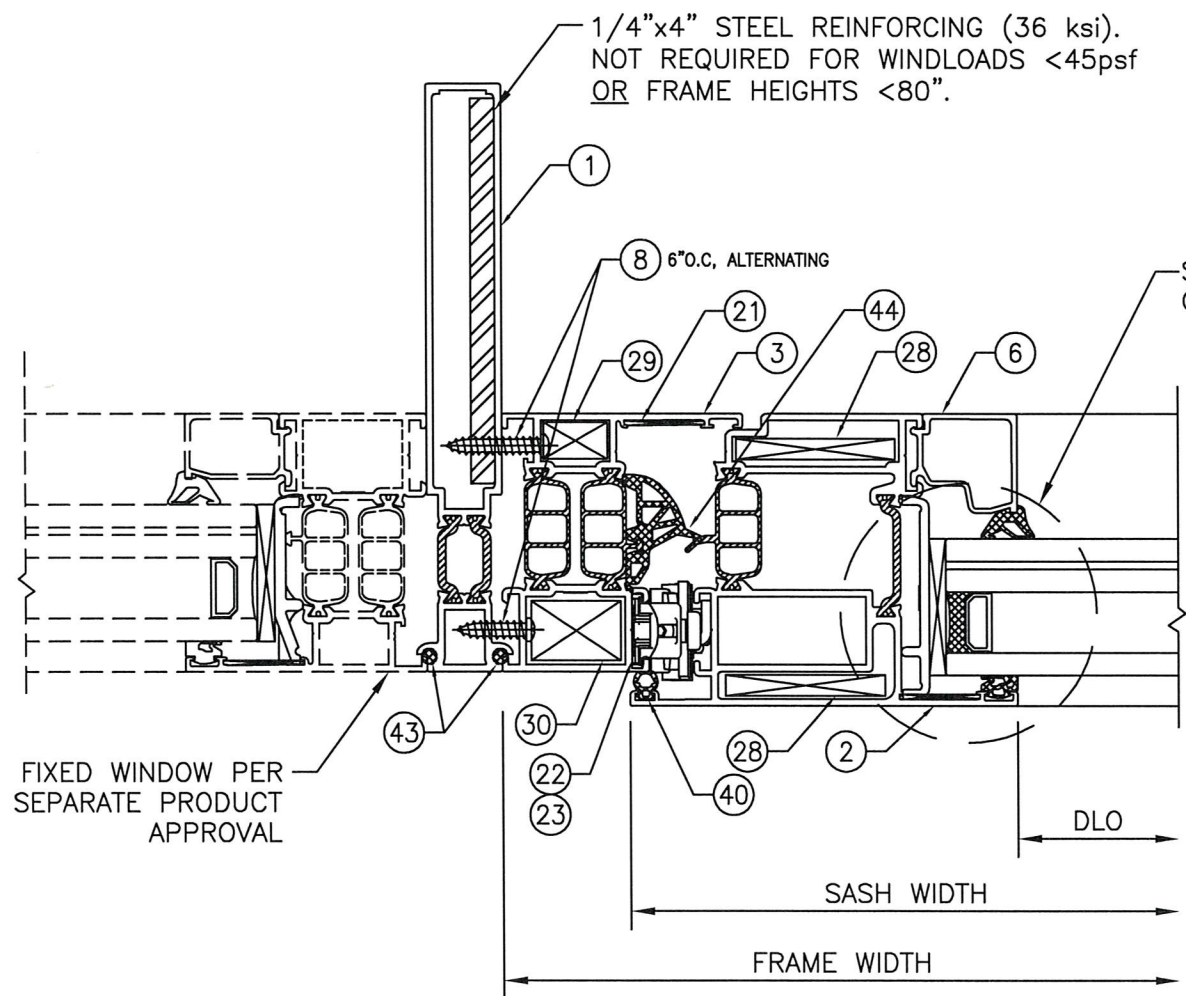

FIXED WINDOW PER SEPARATE PRODUCT APPROVAL

SEE GLAZING DETAIL ON SHEET 3.

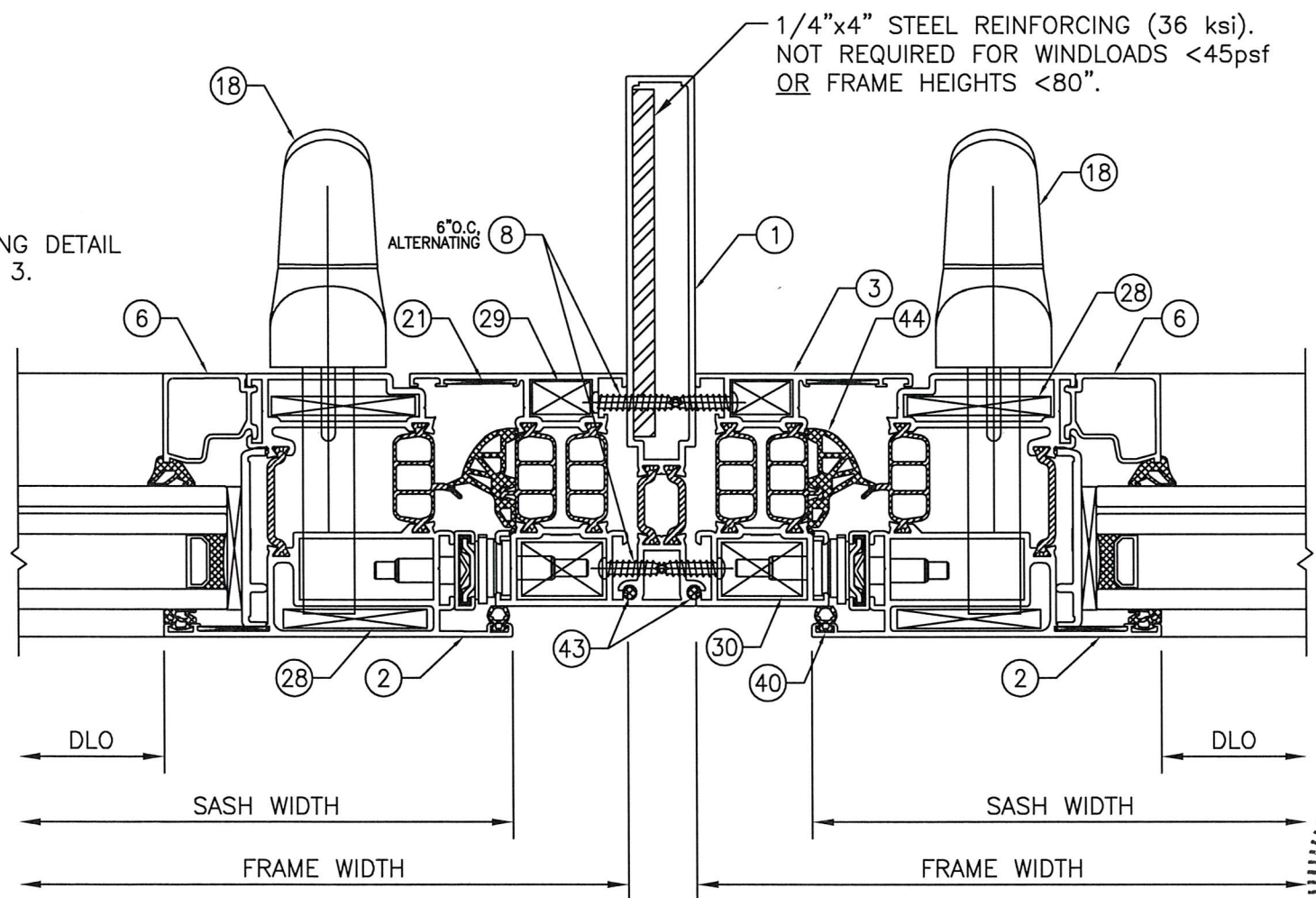

EXTERIOR

5
5

6
5

CS77 SERIES CASEMENT WINDOW

REYNAERS, INC.
 21430 NORTH 15TH LANE, SUITE 111
 PHOENIX, AZ 85027
 Ph: (480) 272-9688
 www.reynaers.com

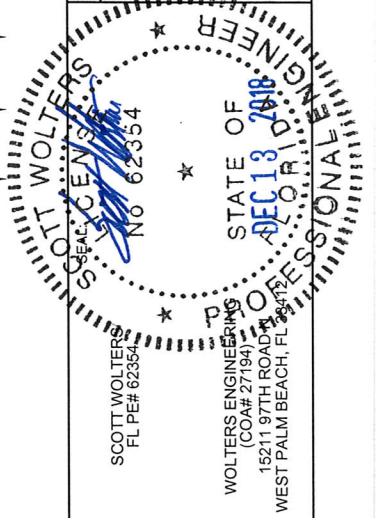

DRAWING NO. CS77CASELMI
 SHEET NO. 5 OF 7

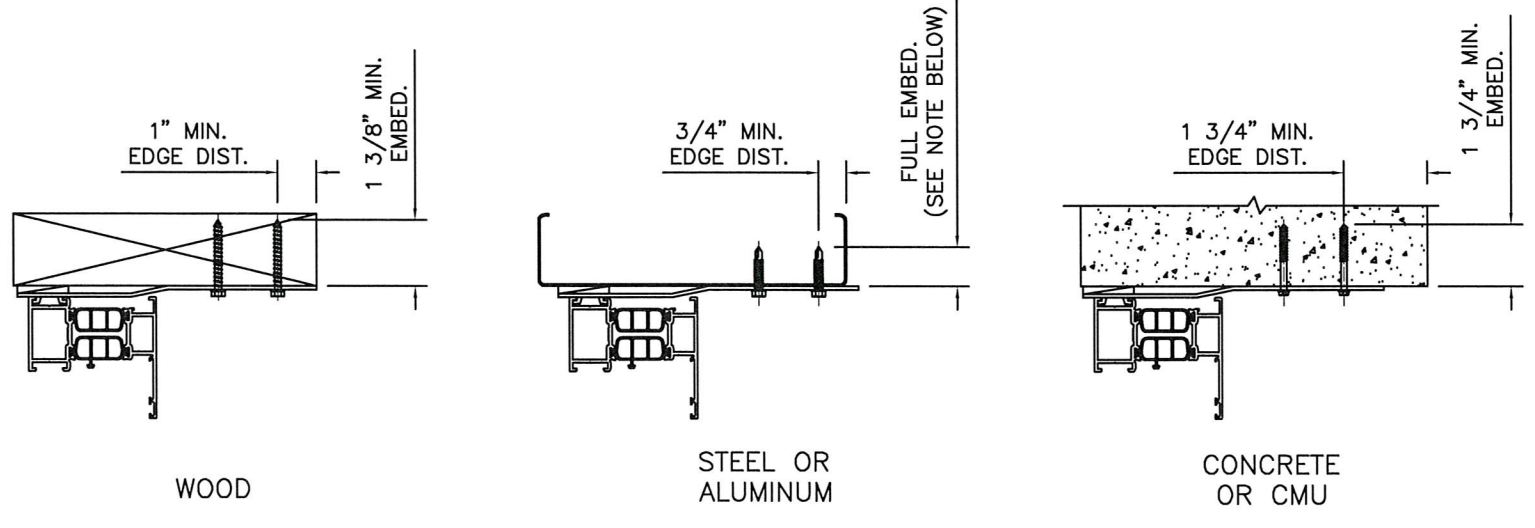
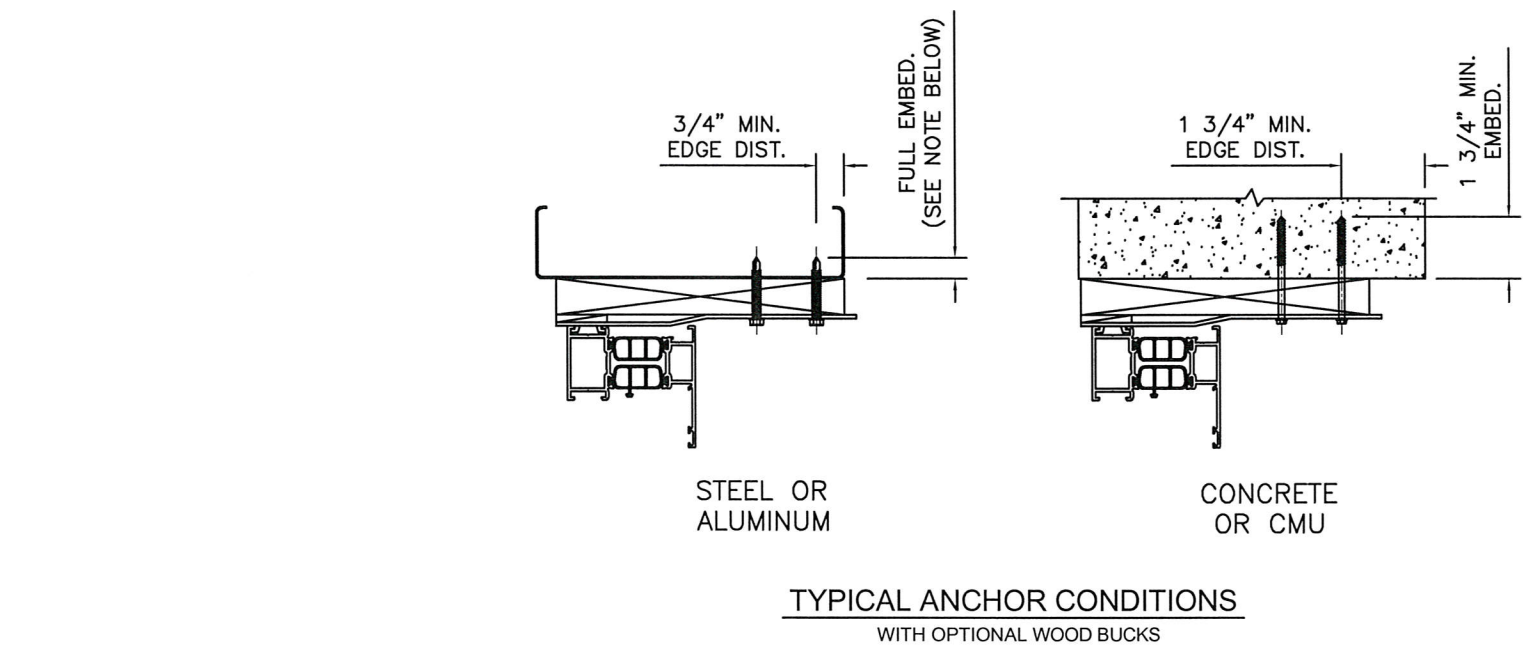
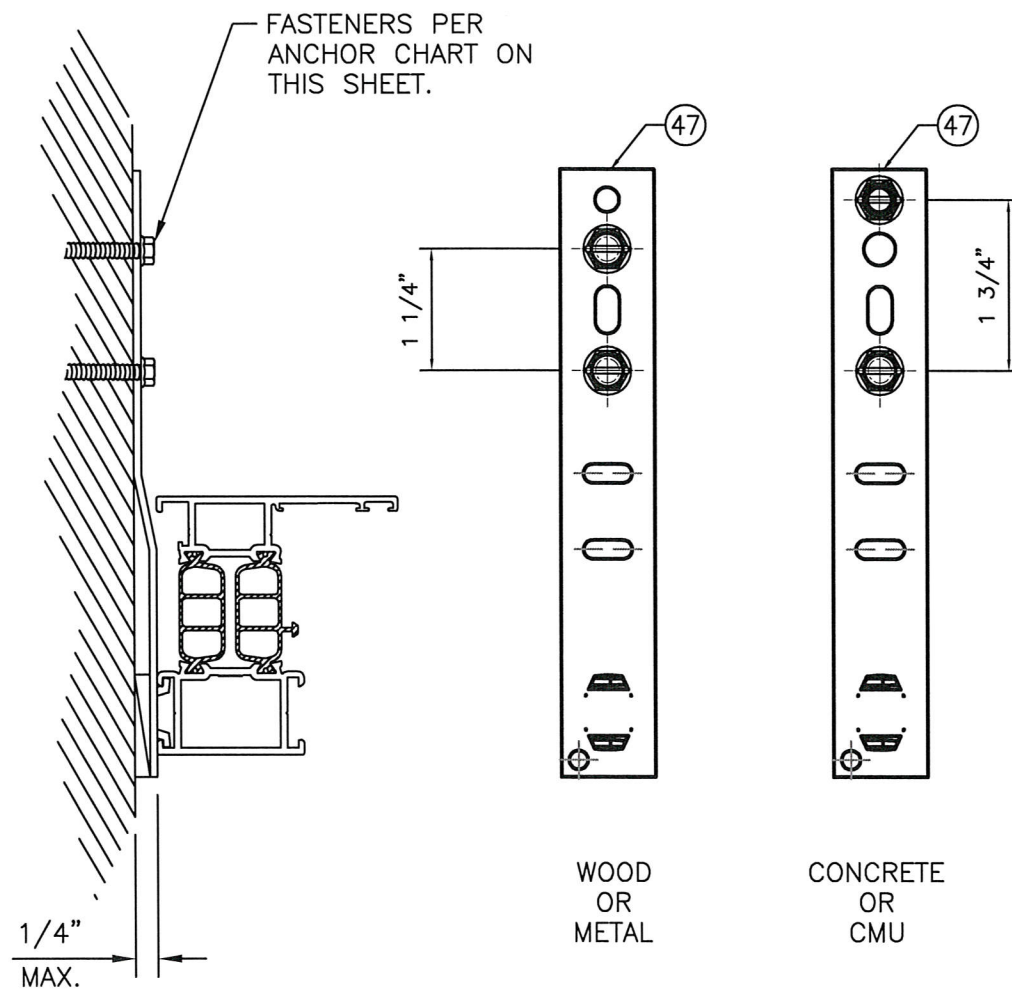

FRAME ANCHOR CHART:

SUBSTRATE	ANCHOR	MIN. EMBEDMENT	MIN. EDGE DISTANCE	SPACING
WOOD (2x, S.G.= 0.55 MIN)	#14 WOOD SCREW (Gr. 5 MIN)	1 3/8"	1"	1 1/4"
STEEL STUD (16 Ga, 33 KSI MIN)	1/4"-14 ITW TEKS SCREW, ELCO DRIL-FLEX, or ELCO SS BI-FLEX	FULL*	3/4"	1 1/4"
ALUM. (1/8" 6063-T5 MIN) OR STEEL (1/8", 33 KSI MIN)	1/4"-14 ITW TEKS SCREW, ELCO DRIL-FLEX, or ELCO SS BI-FLEX	FULL*	3/4"	1 1/4"
CONCRETE (3000 PSI MIN)	1/4" DIA. ITW TAPCON, ELCO ULTRACON, or ELCO SS AGGRE-GATOR	1 3/4"	1 3/4"	1 3/4"
GROUT-FILLED CMU (ASTM C90 MIN)	1/4" DIA. ITW TAPCON, ELCO ULTRACON, or ELCO SS AGGRE-GATOR	1 3/4"	2 1/2"	1 3/4"

* FULLY PENETRATES METAL WITH 3 THREADS BEYOND

DATE:	7/30/18
REVISION DESCRIPTION	
NO.	

REYNAERS, INC.

21430 NORTH 15TH LANE, SUITE 111
PHOENIX, AZ 85027
Ph: (480) 272-9688
www.reynaers.com

CS77 SERIES CASEMENT WINDOW

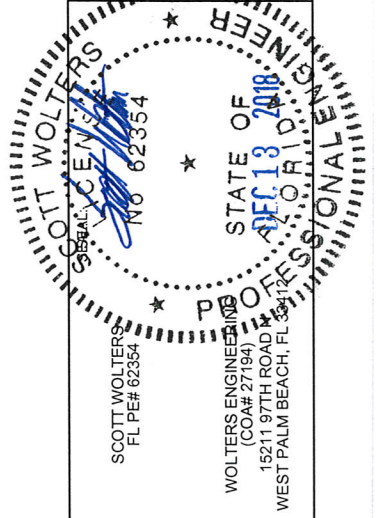

DRAWING NO.	CS77CASELMI
SHEET NO.	6 of 7

Bill of Materials

Profiles					
ID Mark	Part Number	Description	Material	Manufacturer	Notes
1	0060371.51	Connection Profile	AW 6060 T66	Reynaers	
2	0083052.51	Window Vent Outward Opening	AW 6060 T66	Reynaers	
3	0083183.51	Outer Frame 64mm	AW 6060 T66	Reynaers	
4	0300019.51	Drip cap	AW 6060 T66	Reynaers	
5	0303649.51	Glazing Bead	AW 6060 T66	Reynaers	
6	0303652.51	Glazing Bead 29.2mm	AW 6060 T66	Reynaers	

Accessories and Hardware					
ID Mark	Part Number	Description	Material	Manufacturer	Notes
7	0215169.--	Screw Self-Drilling M5x11	stainless steel	Reynaers	
8	0525310.--	st-Screw din 7981 Inox 4.2x16	stainless steel	Nestinox	
9	0525327.--	Screw DIN 7982 Inox 4.2x25	stainless steel	Fabory	
10	0606007.--	Adjustment rod 400mm	PA6	Sobinco	
11	0606010.--	Adjustment rod 250mm	PA6	Sobinco	
12	0606013.--	Adjustment rod 400mm	PA6	Sobinco	
13	0606014.--	Connecting rod 365mm	PA6	Sobinco	
14	0606016.--	Connecting rod 160mm	PA6	Sobinco	
15	0606042.--	Lock Plate	zinc, stainless steel	Sobinco	
16	0606107.--	Adjustment rod 60mm	aluminum	Sobinco	
17	0606150.--	Connecting rod 110mm	PA6	Sobinco	
18	0606543	Handle		Sobinco	
19	0607161.--	Drive plate set outward opening		Sobinco	
20	0607162.--	Restrictor set outward opening		Sobinco	
21	0608746.00	Rebate Support 16.4x3.5	Zamac 5	Pedeo	
22	0609012.--	Hinge Side Tuti Left 671<fb<1300		Sobinco	
23	0609013.--	Hinge Side Tuti Right 671<fb<1300		Sobinco	
24	0609016.--	Reinforcement set Invision fg >130kg	Aluminum, stainless steel	Sobinco	
25	0609204.--	Central closure safe	zamac 5, stainless steel	Sobinco	
26	0609205.--	Central closure safe	zamac 5, stainless steel	Sobinco	
27	0609710.--	Handle side TUTI burglar protection		Sobinco	
28	0687771.00	Crimp Corner Cleats 10.3x43.8	die cast alu	Monticelli	
29	0687853.00	Crimp Corner Cleat 17.85x10.45	die cast alu	Monticelli or Fratelli	
30	0687952.00	Corner Cleat 26.05x17.4	die cast alu	Fratelli Comunello	
31	0696660.04	end Piece 030.0019.xx	PA	Stockplastics	
32	0696831.04	Weep hole cover	ASA	Custers kunststoffen or	
33	0698704.01	Glass Support	POM	Custers kunststoffen	
34	0698748.01	Glass Support	POM	Custers kunststoffen	
35		Glass Setting Block/Comer Block	Neoprene		(1)Sill, (1)ea. Jamb, (1)Head
36	0849108.--	Reynafix	synthetic rubber	Novatio	
37	0869208.SY	Reynaprotector	silicone	Weiss Chemie + Technik	
38	0849080.--	Reynaseal duo	Cosmofen duo	Weiss Chemie + Technik	

Gaskets					
ID Mark	Part Number	Description	Material	Manufacturer	Notes
40	0808442.04	Acoustic Gasket	EPDM + cellular EPDM	Polecex	
41	8809114.04	Outer Glazing Gasket	EPDM	Polecex	
42	8809126.04	Inner Glazing Gasket	EPDM	Polecex	
43	0809381.04	Gasket 4.3mm	EPDM foam	Polecex	Install with Sealant
44	8809657.04	Central Gasket	EPDM	Polecex	

Building Connection					
ID Mark	Part Number	Description	Material	Manufacturer	Notes
45		Silicone DC 790	silicone	Dow Corning	
46		Ilmod 600 15/5-10mm	PU foam	Tremco Ilbruck	
47	0566016.--	Fixing lug	low carbon galvanized steel	MS Decoupe	

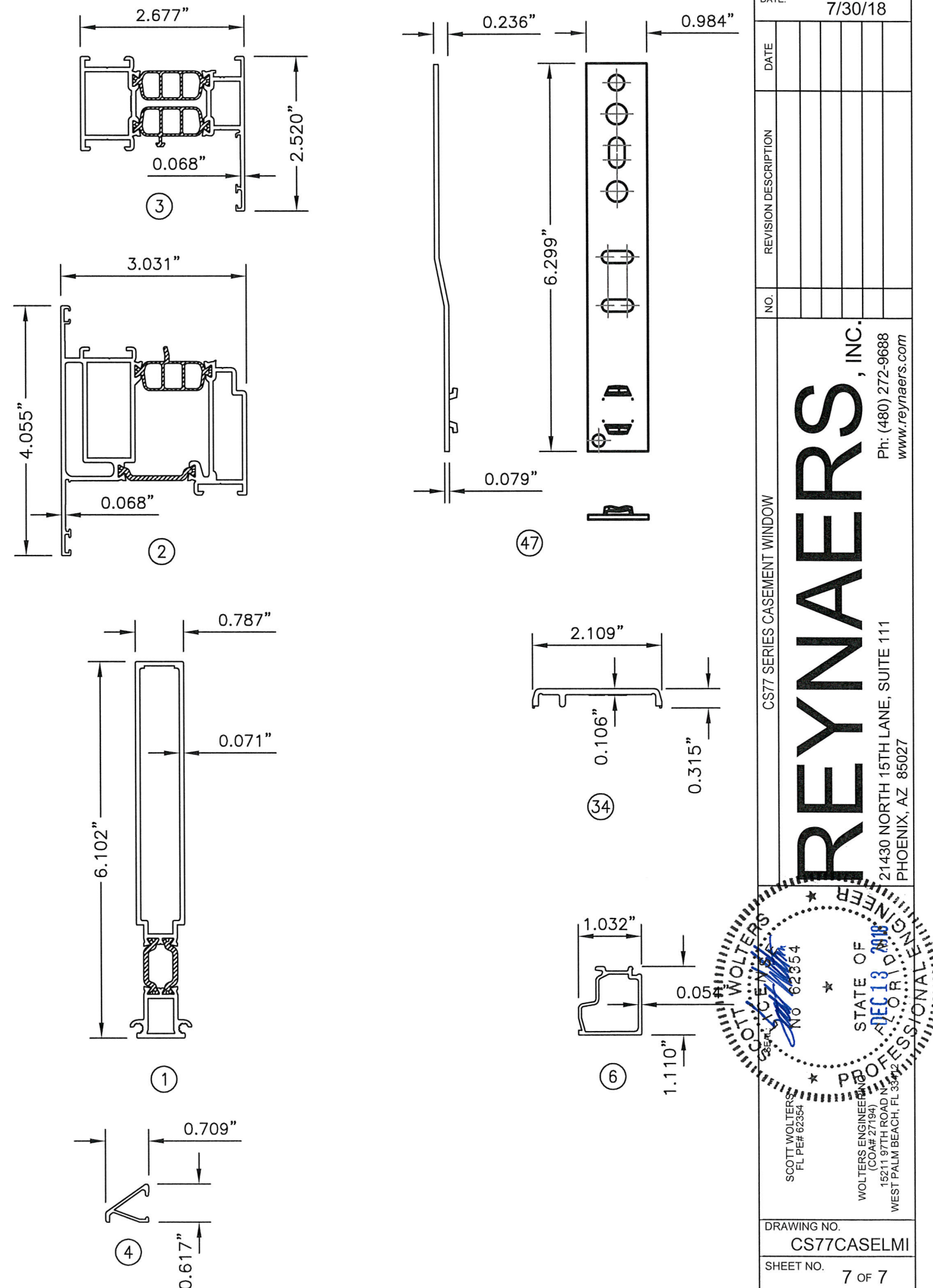

DATE: 7/30/18

REVISION DESCRIPTION

NO.

REYNAERS, INC.

21430 NORTH 15TH LANE, SUITE 111
PHOENIX, AZ 85027

Ph: (480) 272-9688
www.reynaers.com

CS77 SERIES CASEMENT WINDOW

DRAWING NO. CS77CASELMI
SHEET NO. 7 OF 7