

CRAWFORD TRACEY CORPORATION

PRO-TECH 45SG ALUMINUM CURTAINWALL SYSTEM

L.M.I. & S.M.I. (MISSILE LEVEL "D" & "E")

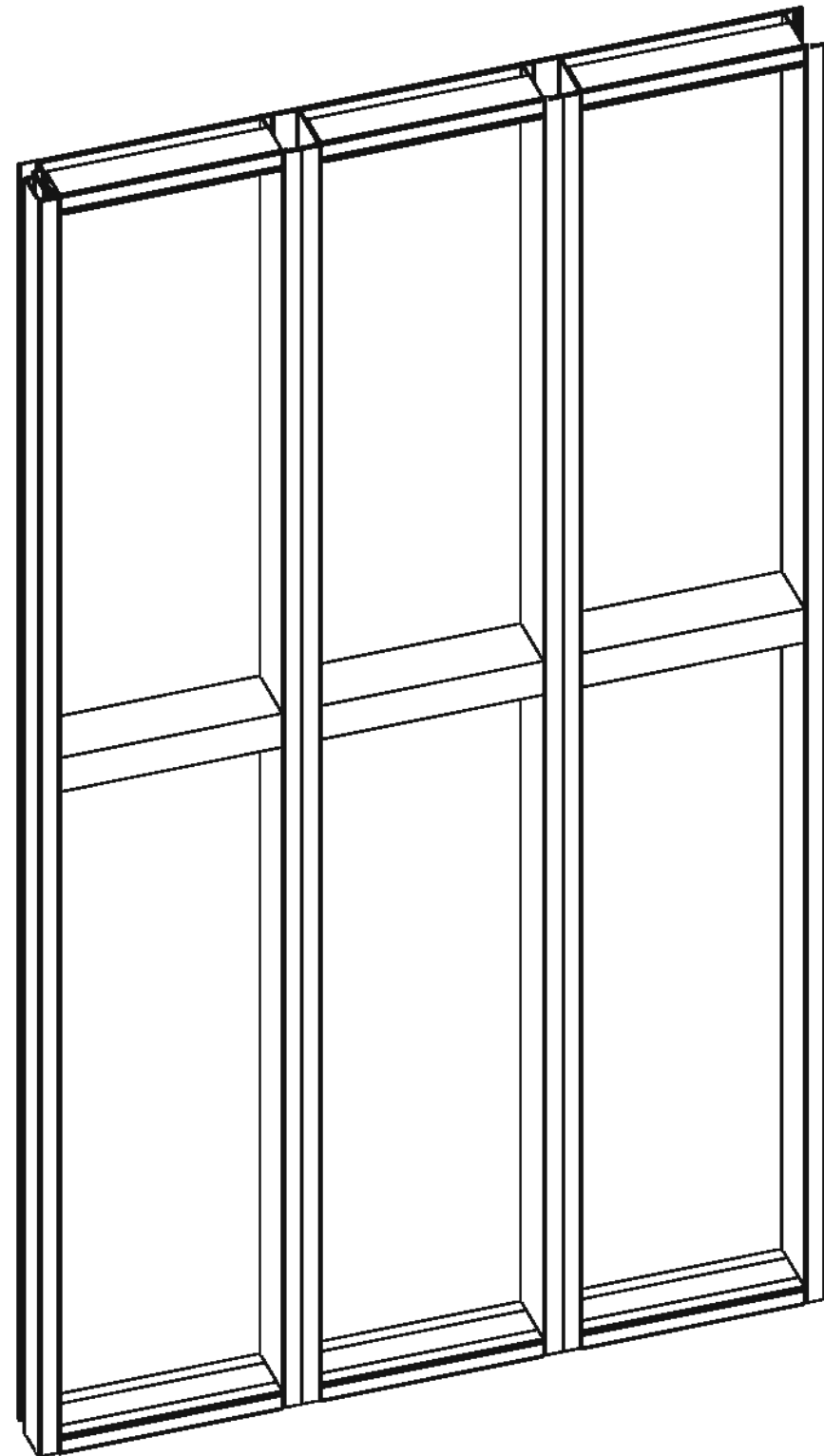

GENERAL NOTES:

1. THE SYSTEM AND GLASS TYPES DESCRIBED HEREIN COMPLY AND HAVE BEEN DESIGNED AND TESTED IN ACCORDANCE WITH THE FLORIDA BUILDING CODE SEVENTH EDITION (2020) PER
 - a. ASTM E330-14, E331-00, E283-04, E1886-13a, E1996-14
 - b. TAS 201 / 202 / 203
 - c. AAMA 501
 - d. ANSI Z97.1-2015 (400 ft-lb. IMPACT)
2. FOR USE WITHIN AND OUTSIDE THE HIGH VELOCITY HURRICANE ZONE (HVHZ).
3. DESIGN PRESSURES NOTED HEREIN ARE BASED ON MAXIMUM TESTED PRESSURES DIVIDED BY A 1.5 SAFETY FACTOR.
4. NO 33-1/3% INCREASE IN ALLOWABLE STRESS HAS BEEN USED IN THE DESIGN OF THIS SYSTEM. WIND LOAD DURATION FACTOR Cd=1.6 HAS BEEN USED FOR WOOD ANCHOR DESIGN.
5. THE ARCHITECT/ENGINEER OF RECORD FOR THE PROJECT SUPERSTRUCTURE WITH WHICH THIS DESIGN IS USED SHALL BE RESPONSIBLE FOR THE INTEGRITY OF ALL SUPPORTING SURFACES TO THIS DESIGN WHICH SHALL BE COORDINATED BY THE PERMITTING CONTRACTOR. WOOD BUCKS (BY OTHERS) SHALL BE ANCHORED PROPERLY TO TRANSFER LOADS TO THE EXISTING STRUCTURE.
6. THE SYSTEM DETAILED HEREIN IS GENERIC AND DOES NOT PROVIDE INFORMATION FOR A SPECIFIC SITE. FOR SITE CONDITIONS DIFFERENT FROM THE CONDITIONS DETAILED HEREIN, A LICENSED ENGINEER OR REGISTERED ARCHITECT SHALL PREPARE SITE SPECIFIC DOCUMENTS FOR USE IN CONJUNCTION WITH THIS DOCUMENT.
7. THE CONTRACTOR IS RESPONSIBLE TO INSULATE ALL MEMBERS FROM DISSIMILAR MATERIALS TO PREVENT ELECTROLYSIS.
8. FASTENERS SHALL BE CADMIUM-PLATED OR OTHERWISE CORROSION-RESISTANT MATERIAL AND SHALL COMPLY WITH "SPECIFICATIONS FOR ALUMINUM STRUCTURES" SECTION J.3.7.2 BY THE ALUMINUM ASSOCIATION, INC., & ANY APPLICABLE FEDERAL, STATE, AND/OR LOCAL CODES
9. ENGINEER SEAL AFFIXED HERE TO VALIDATES STRUCTURAL DESIGN AS SHOWN ONLY. USE OF THIS SPECIFICATION BY CONTRACTOR, et. al. INDEMNIFIES & SAVES HARMLESS THIS ENGINEER FOR ALL COST & DAMAGES INCLUDING LEGAL FEES & APPELLATE FEES RESULTING FROM MATERIAL FABRICATION, SYSTEM ERECTION, & CONSTRUCTION PRACTICES BEYOND THAT WHICH IS CALLED FOR BY LOCAL, STATE, & FEDERAL CODES & FROM DEVIATIONS OF THIS PLAN.
10. EXCEPT AS EXPRESSLY PROVIDED HEREIN, NO ADDITIONAL CERTIFICATIONS OR AFFIRMATIONS ARE INTENDED.
11. PRESSURE VALUES ON THIS APPROVAL ARE (ASD) ALLOWABLE DESIGN PRESSURES.
12. ALTERATIONS, ADDITIONS, OR OTHER MARKINGS TO THIS DOCUMENT ARE NOT PERMITTED AND INVALIDATE THIS CERTIFICATION.
13. SAFEGUARDS MUST BE OBSERVED (NOT IN THIS CERTIFICATION)
14. IF SLOPED GLAZING IS NEEDED, IT SHALL BE ALLOWED UNDER SITE SPECIFIC ENGINEERING. DESIGN MUST BE CHECKED AND APPROVED BY A PROFESSIONAL ENGINEER AND MANUFACTURER.
15. PRODUCT SHALL BE PERMANENTLY LABELED WITH A MINIMUM OF ONE LABEL PER SYSTEM CONTAINING THE FOLLOWING:
 CRAWFORD TRACEY CORPORATION
 3301 S.W. 13th DRIVE
 DEERFIELD BEACH, FLORIDA 33442
 TAS 201/202/203
 APPROVED BY FLORIDA BUILDING COMMISSION
 FLORIDA PRODUCT APPROVAL NUMBER FL# 29520

SHEET INDEX

# SHEET	DESCRIPTION
01	COVER SHEET
02	ELEVATIONS
03-17	GLASS LOADING TABLES
18	MULLION LOADING TABLES
19	SIDE LOADED FRAME
20-25	DETAILS
26-32	ANCHOR LAYOUT & ANCHOR CAPACITY TABLES
33-35	EXTRUSIONS / PART LIST/ FRAME ASSEMBLY
35	TOTAL

VISIT ECALC.IO/32267
 FOR HELPFUL RESOURCES, SITE
 SPECIFIC JOB ORDERING & MORE
 INFORMATION ABOUT THIS PRODUCT &
 RELATED SERVICES

SCAN HERE:



FRANK BENNARDO, P.E.
 PE# 0046549 CA 9885



FL#29520.4

ENGINEERING EXPRESS
 CORPORATE OFFICE:
 160 SW 12th AVE, SUITE 106
 DEERFIELD BEACH, FL 33442
 (954) 354-0660 | (866) 996-9999
 TEAM@ENGINEERINGEXPRESS.COM
 ENGINEERINGEXPRESS.COM

CRAWFORD TRACEY CORPORATION

3301 S.W. 13th DRIVE
 DEERFIELD BEACH, FL, 33442-8101
 Phn. (954) 698-6888

PRO-TECH 45SG ALUMINUM CURTAINWALL SYSTEM
 FLORIDA STATE APPROVAL

REMARKS
 FBC 2020 UPDATE

DATE
 10/19/20

CHKD
 AJP

DRWN
 JEM

DATE
 10/19/20

DATE
 10/19/20

DATE
 10/19/20

THIS DOCUMENT IS THE PROPERTY OF ENGINEERING EXPRESS, AND SHALL NOT BE REPRODUCED IN WHOLE OR PART WITHOUT WRITTEN CONSENT OF ENGINEERING EXPRESS. ALTERATIONS, ADDITIONS, OR OTHER MARKINGS TO THIS DOCUMENT ARE NOT PERMITTED AND INVALIDATE OUR CERTIFICATION.

COPYRIGHT ENGINEERING EXPRESS

20-32267

SCALE: NTS UNLESS NOTED

01





FL#29520.4

ENGINEERING EXPRESS
CORPORATE OFFICE:
160 SW 12th AVE, SUITE 106
DEERFIELD BEACH, FL 33442
(954) 354-0660 | (866) 396-9999
TEAM@ENGINEERINGEXPRESS.COM
ENGINEERINGEXPRESS.COM

CRAWFORD TRACEY CORPORATION

3301 S.W. 13th DRIVE
DEERFIELD BEACH, FL, 33442-8101
Phn. (954) 698-6888

PRO-TECH 455G ALUMINUM CURTAINWALL SYSTEM
FLORIDA STATE APPROVAL

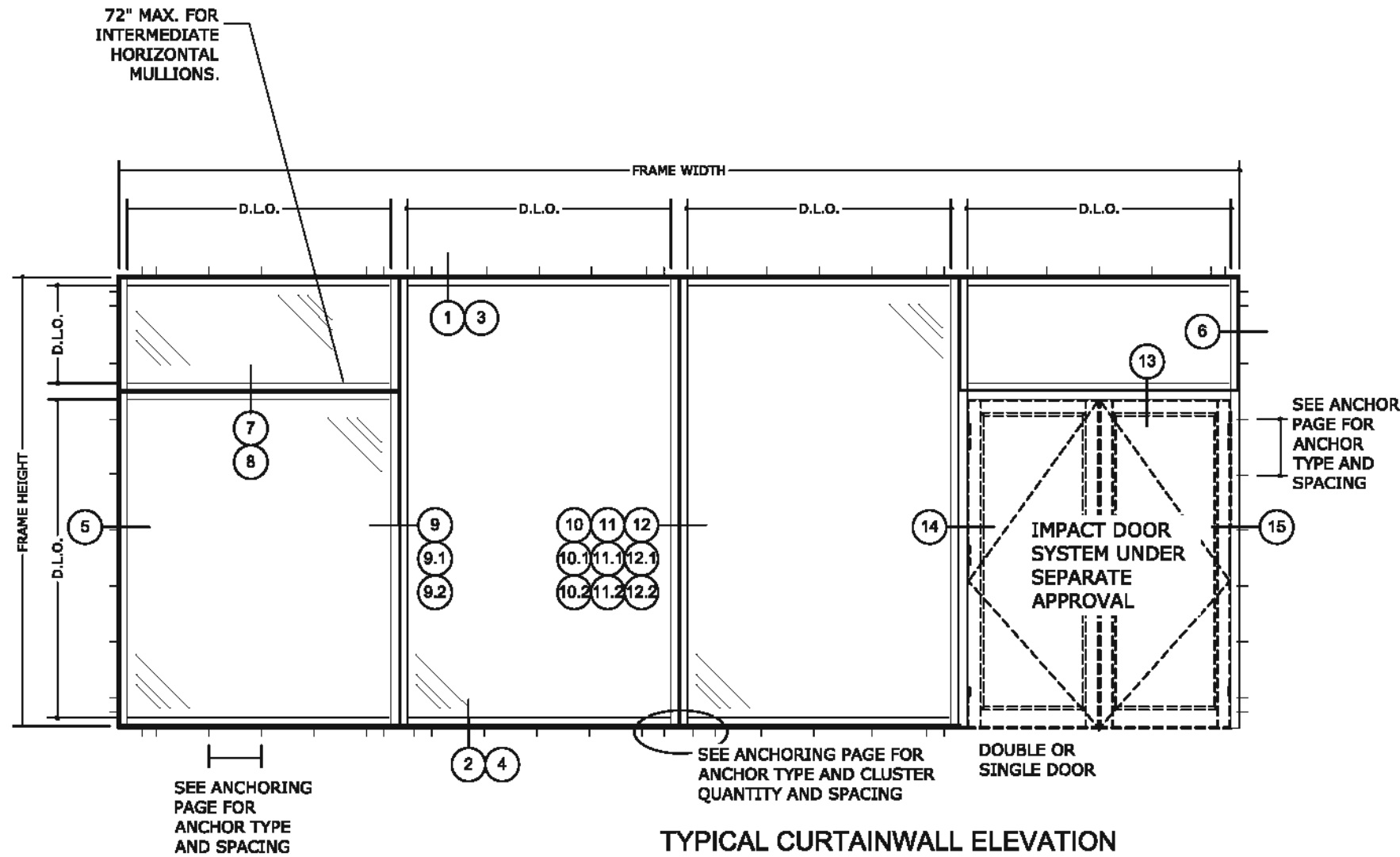

TYPICAL CURTAINWALL ELEVATION

SEE PAGE 3 FOR ALL ALTERNATE SUNSHADES UNDER THIS APPROVAL

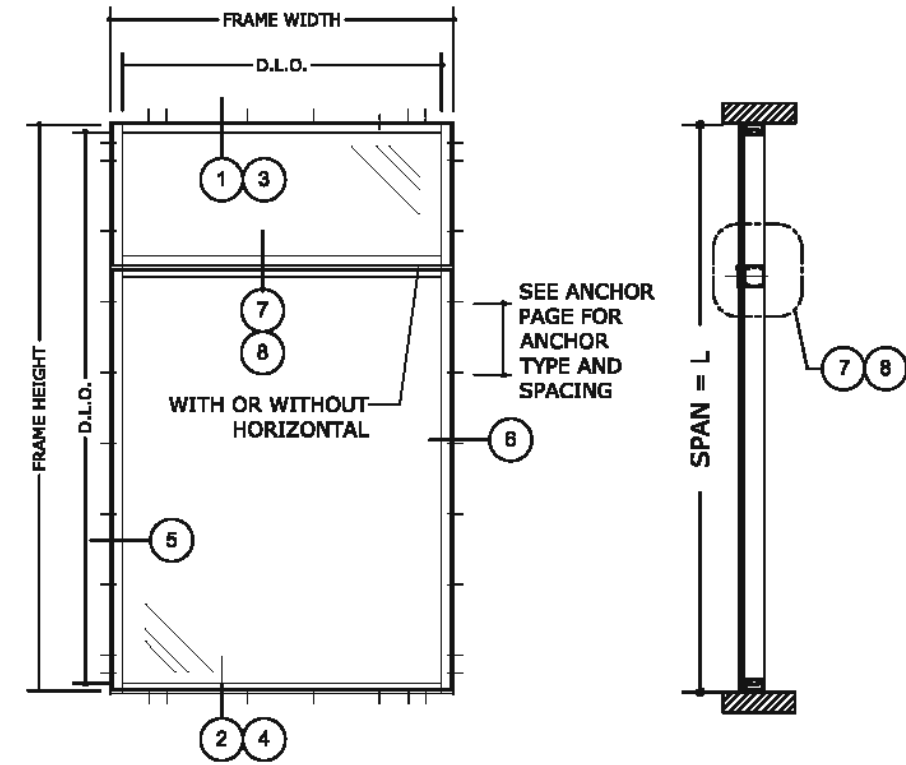

TYPICAL SINGLE PANEL OPENING

FRAME SIZE FOR SINGLE OPENINGS SHALL BE GOVERNED BY THE MAXIMUM ALLOWABLE D.L.O. DIMENSIONS DISPLAYED ON THE GLASS CHARTS

SECTION "A"

SINGLE SPAN

INTERMEDIATE HORIZONTAL NOTES:
72" MAX. FOR INTERMEDIATE HORIZONTAL MULLIONS.

WATER INFILTRATION NOTE:
THIS SYSTEM HAS BEEN TESTED TO WITHSTAND UP TO A 100 PSF WATER LOAD

INSTRUCTIONS TO DETERMINE DESIGN PRESSURE RATING

- STEP ①: USE THE GLASS LOADING TABLES TO DETERMINE THE ALLOWABLE PRESSURE OF THE GLASS.
- STEP ②: USE THE MULLION LOADING TABLE TO DETERMINE THE ALLOWABLE PRESSURES FOR THE MULLIONS.
- STEP ③: THE MINIMUM VALUE BETWEEN STEP ① AND STEP ② WILL DETERMINE THE DESIGN LOAD PRESSURE FOR THE CURTAIN WALL SYSTEM.

REMARKS	DATE	CHKD	DATE
FBC 2020 UPDATE	10/19/20	JEM	AJP

THIS DOCUMENT IS THE PROPERTY OF ENGINEERING EXPRESS, AND SHALL NOT BE REPRODUCED IN WHOLE OR PART, WITHOUT WRITTEN CONSENT OF ENGINEERING EXPRESS. ALTERATIONS, ADDITIONS, OR OTHER MARKINGS TO THIS DOCUMENT ARE NOT PERMITTED AND INVALIDATE OUR CERTIFICATION.

COPYRIGHT ENGINEERING EXPRESS

20-32267

SCALE: NTS UNLESS NOTED

02



GLASS TYPES (L.M.I.)

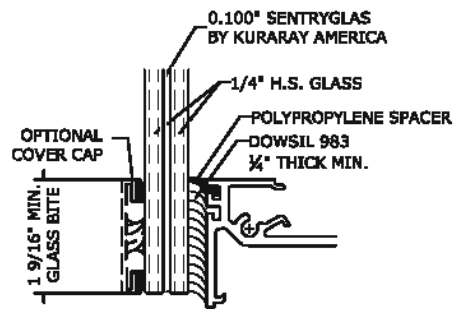

GLASS TYPE A
GLAZING DETAIL
 N.T.S.
GLASS RATING:
 LARGE MISSILE LEVEL D
 1/8" GLASS

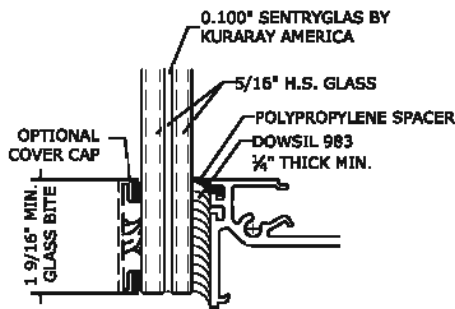

GLASS TYPE B
GLAZING DETAIL
 N.T.S.
GLASS RATING:
 LARGE MISSILE LEVEL D
 3/16" GLASS

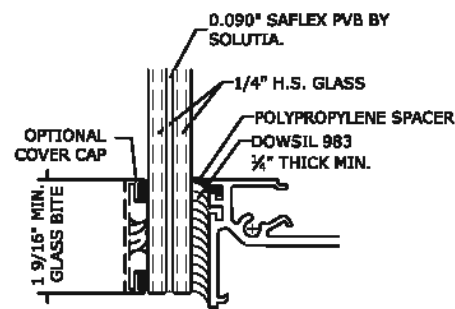

GLASS TYPE D
GLAZING DETAIL
 N.T.S.
GLASS RATING:
 LARGE MISSILE LEVEL D
 3/16" GLASS

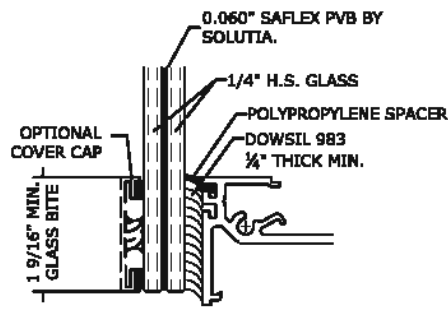

GLASS TYPE H
GLAZING DETAIL
 N.T.S.
GLASS RATING:
 LARGE MISSILE LEVEL D
 3/16" GLASS

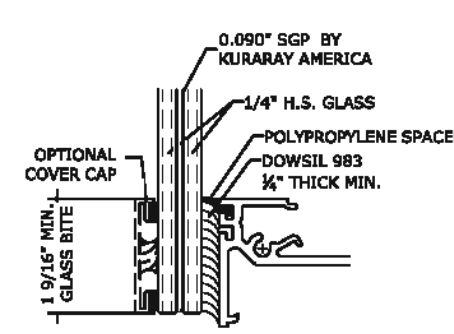

GLASS TYPE I
GLAZING DETAIL
 N.T.S.
GLASS RATING:
 LARGE MISSILE LEVEL D
 3/16" GLASS

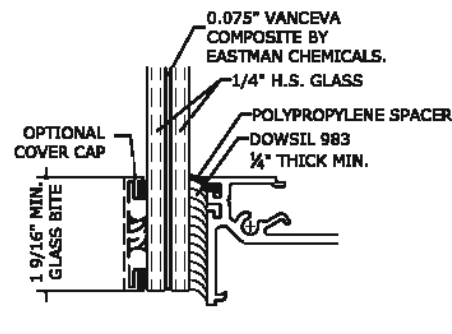

GLASS TYPE J
GLAZING DETAIL
 N.T.S.
GLASS RATING:
 LARGE MISSILE LEVEL D
 3/16" GLASS

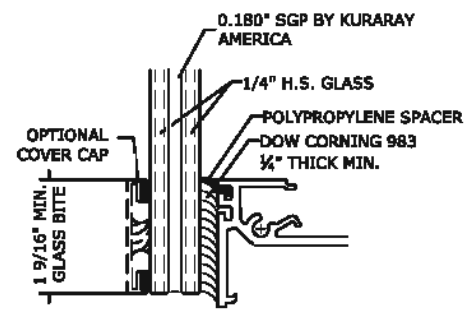

GLASS TYPE K
GLAZING DETAIL
 N.T.S.
GLASS RATING:
 LARGE MISSILE LEVEL E
 3/8" GLASS

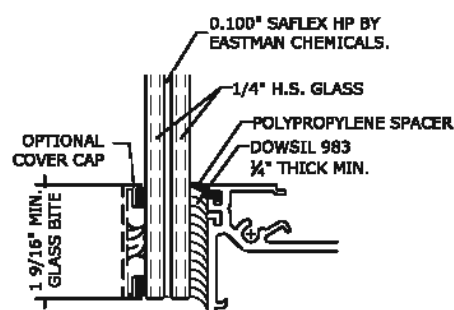

GLASS TYPE L
GLAZING DETAIL
 N.T.S.
GLASS RATING:
 LARGE MISSILE LEVEL D
 3/8" GLASS

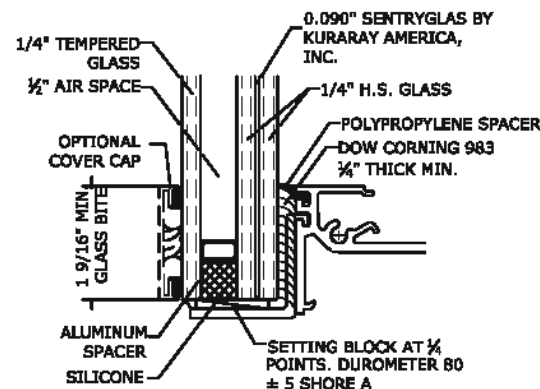

GLASS TYPE B1
GLAZING DETAIL
 N.T.S.
GLASS RATING:
 LARGE MISSILE LEVEL D
 1 1/8" GLASS

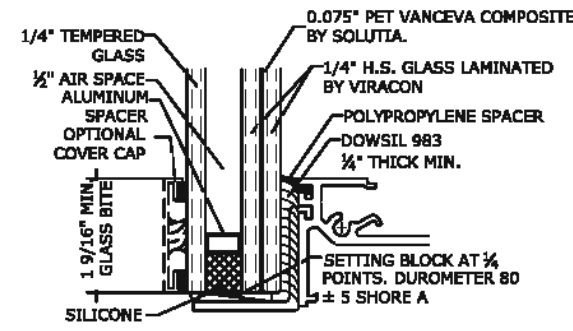

GLASS TYPE C1
GLAZING DETAIL
 N.T.S.
GLASS RATING:
 LARGE MISSILE LEVEL E
 1 3/8" GLASS

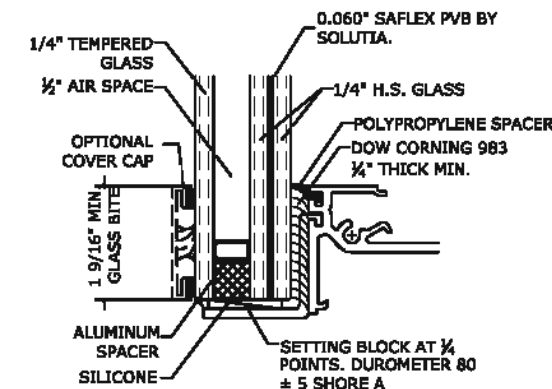

GLASS TYPE D1
GLAZING DETAIL
 N.T.S.
GLASS RATING:
 LARGE MISSILE LEVEL D
 1 3/8" GLASS

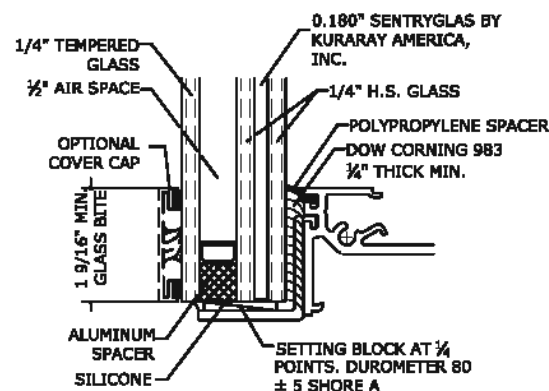

GLASS TYPE E1
GLAZING DETAIL
 N.T.S.
GLASS RATING:
 LARGE MISSILE LEVEL E
 1 3/8" GLASS

NOTES:

THICKER GLASS LITES MAY BE USED IN THE SAME CONFIGURATIONS AS SHOWN ABOVE, AS REQUIRED ON A SITE SPECIFIC BASIS. IF THICKER LITES ARE USED, IT SHALL BE CHECKED AND APPROVED BY A PROFESSIONAL ENGINEER.

CURVED OR BENT GLAZING MAY BE USED IN THE SAME CONFIGURATIONS AS SHOWN ABOVE, IN ACCORDANCE WITH SITE SPECIFIC REQUIREMENTS. IF CURVED OR BENT GLAZING IS USED, IT SHALL BE CHECKED AND APPROVED BY A PROFESSIONAL ENGINEER AND THE MANUFACTURER. FINAL APPROVAL SHALL BE GIVEN BY STATE AUTHORITY HAVING JURISDICTION.

NON-LAMINATED, MONOLITHIC GLASS MAY BE USED IN PLACE OF THE LAMINATED OPTIONS, SHOWN ON PAGE ABOVE, GIVEN THAT THE GLASS TO BE USED IS LABELED AS "NON-IMPACT RESISTANT" AND IS DESIGNED TO MEET ASTM E-1300 STANDARDS. THE SUBSTITUTED GLAZING MUST BE CHECKED AND APPROVED BY A PROFESSIONAL ENGINEER AND THE MANUFACTURER

NOTES:

- GLAZED GEOMETRICAL SHAPES MAY BE USED PROVIDED THEY FIT INSIDE THE APPROVED INSCRIBED SIZES.
- GLAZING DETAILS WITH A SILICONE BITE OF 1 3/8" ARE PERMITTED TO BE DECREASED TO A MINIMUM OF 1 3/8" SILICONE BITE, PROVIDED THE ALLOWABLE PRESSURES SHOWN ON GLASS CHARTS ARE DECREASED BY 16%
- OPTION OF .019" CERAMIC FRIT ON ROOM SIDE SURFACE OF INNER PANE GLASS
- GLASS MAY BE VERTICALLY OR HORIZONTALLY ORIENTED
- OPTIONAL GLASS CAPS, FINS, OR SIMILAR ACCESORIES OF VARIOUS SIZES MAY BE ATTACHED WITH SILICONE, BASED ON SITE SPECIFIC CALCULATIONS
- CONDITIONS WHERE THE GLASS EXTENDS PAST THE FRAME ARE ALLOWED AS LONG AS THE GLASS IS SUPPORTED BY A STRUCTURALLY SOUND SUBSTRATE. THIS CONDITION SHALL REQUIRE APPROVAL BY A PROFESSIONAL ENGINEER.
- NON IMPACT GLASS TO BE DESIGNED ON A SITE SPECIFIC BASIS AND APPROVED BY A PROFESSIONAL ENGINEER.
- GLASS PLIES NOT IN CONTACT WITH STRUCTURAL SILICONE MAYBE A GREATER THICKNESS THAN THOSE SHOWN, AND SHALL BE CHECKED AND APPROVED BY THE MANUFACTURER AND PROFESSIONAL ENGINEER ON A SITE SPECIFIC BASIS.

FRANK BENNARDO, P.E.
 PE# 0046549 CA 9885



FL#29520.4

ENGINEERING EXPRESS
 CORPORATE OFFICE:
 160 SW 12th AVE, SUITE 106
 DEERFIELD BEACH, FL 33442
 (954) 354-0660 | (866) 996-9999
 TEAM@ENGINEERINGEXPRESS.COM
 ENGINEERINGEXPRESS.COM

CRAWFORD TRACEY CORPORATION
 3301 S.W. 13th DRIVE
 DEERFIELD BEACH, FL, 33442-8101
 Phn. (954) 698-6888
 PRO-TECH 455G ALUMINUM CURTAINWALL SYSTEM
 FLORIDA STATE APPROVAL

REMARKS	DATE	DRWN	CHKD
FRC 2020 UPDATE	10/19/20	JEM	AJP

THIS DOCUMENT IS THE PROPERTY OF ENGINEERING EXPRESS, AND SHALL NOT BE REPRODUCED IN WHOLE OR PART WITHOUT WRITTEN CONSENT OF ENGINEERING EXPRESS. ALTERATIONS, ADDITIONS, OR OTHER MARKINGS TO THIS DOCUMENT ARE NOT PERMITTED AND INVALIDATE OUR CERTIFICATION.

COPYRIGHT ENGINEERING EXPRESS®

20-32267

SCALE: NTS UNLESS NOTED

03

GLASS TYPE A & B - LOADING CHART (L.M.I.)

72 (in.)		
SIDE A OR B (D.L.O.) (in.)		
SIDE A OR B (D.L.O.) (in.)	(+) P.S.F	(-) P.S.F
36	120	126
42	120	126
48	120	126
54	120	126
60	120	126
66	111	117
72	102	107
78	102	107
84	102	107
90	102	107
96	102	107
102	102	107
108	102	107
114	102	107
120	102	107
126	102	107
132	102	107
138	102	107
144	102	107
150	102	107
156	102	107
162	102	107

84 (in.)		
SIDE A OR B (D.L.O.) (in.)		
SIDE A OR B (D.L.O.) (in.)	(+) P.S.F	(-) P.S.F
36	120	126
42	120	126
48	120	126
54	120	126
60	120	126
66	111	117
72	102	107
78	94	99
84	87	92
90	87	92
96	87	92
102	87	92
108	87	92
114	87	92
120	87	92
126	87	92
132	87	92
138	87	92

96 (in.)		
SIDE A OR B (D.L.O.) (in.)		
SIDE A OR B (D.L.O.) (in.)	(+) P.S.F	(-) P.S.F
36	120	126
42	120	126
48	120	126
54	120	126
60	120	126
66	111	117
72	102	107
78	94	99
84	87	92
90	82	86
96	76	80
102	76	80
108	76	80
114	76	80
120	76	80

108.00 (in.)		
SIDE A OR B (D.L.O.) (in.)		
SIDE A OR B (D.L.O.) (in.)	(+) P.S.F	(-) P.S.F
36	120	126
42	120	126
48	120	126
54	120	126
60	120	126
66	111	117
72	102	107
78	94	99
84	87	92
90	82	86
96	76	80
102	72	75
108	68	71

120 (in.)		
SIDE A OR B (D.L.O.) (in.)		
SIDE A OR B (D.L.O.) (in.)	(+) P.S.F	(-) P.S.F
36	120	126
42	120	126
48	120	126
54	120	126
60	120	126
66	111	117
72	102	107
78	94	99
84	87	92
90	82	86
96	76	80

132 (in.)		
SIDE A OR B (D.L.O.) (in.)		
WIDTH (in.)	(+) P.S.F	(-) P.S.F
36	120	126
42	120	126
48	120	126
54	120	126
60	120	126
66	111	117
72	102	107
78	94	99
84	87	92

144 (in.)		
SIDE A OR B (D.L.O.) (in.)		
WIDTH (in.)	(+) P.S.F	(-) P.S.F
36	120	126
42	120	126
48	120	126
54	120	126
60	120	126
66	111	117
72	102	107
78	94	99

156 (in.)		
SIDE A OR B (D.L.O.) (in.)		
WIDTH (in.)	(+) P.S.F	(-) P.S.F
36	120	126
42	120	126
48	120	126
54	120	126
60	120	126
66	111	117
72	102	107

168.00 (in.)		
SIDE A OR B (D.L.O.) (in.)		
SIDE A OR B (D.L.O.) (in.)	(+) P.S.F	(-) P.S.F
36	120	126
42	120	126
48	120	126
54	120	126
60	120	126
66	111	117

180 (in.)		
SIDE A OR B (D.L.O.) (in.)		
SIDE A OR B (D.L.O.) (in.)	(+) P.S.F	(-) P.S.F
36	120	126
42	120	126
48	120	126
54	120	126
60	120	126

192 (in.)		
SIDE A OR B (D.L.O.) (in.)		
WIDTH (in.)	(+) P.S.F	(-) P.S.F
36	120	126
42	120	126
48	120	126
54	120	126
60	120	126

198 (in.)		
SIDE A OR B (D.L.O.) (in.)		
WIDTH (in.)	(+) P.S.F	(-) P.S.F
36	120	126
42	120	126
48	120	126
54	120	126

204 (in.)		
SIDE A OR B (D.L.O.) (in.)		
WIDTH (in.)	(+) P.S.F	(-) P.S.F
36	120	126
42	120	126
48	120	126
54	120	126

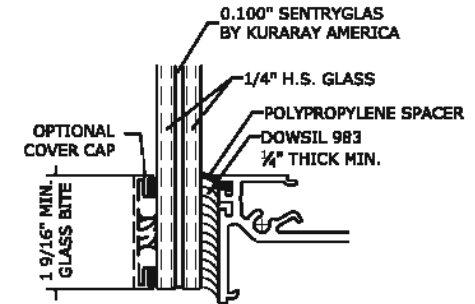

GLASS TYPE A
GLAZING DETAIL
 N.T.S.
GLASS RATING:
 LARGE MISSILE LEVEL D
 3/8" GLASS

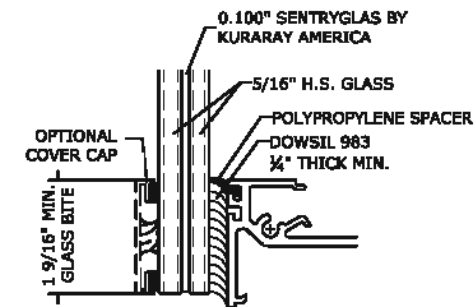

GLASS TYPE B
GLAZING DETAIL
 N.T.S.
GLASS RATING:
 LARGE MISSILE LEVEL D
 3/8" GLASS

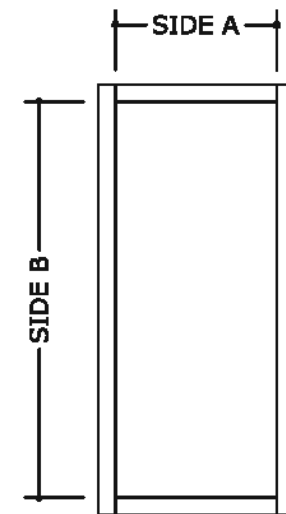

D.L.O. = DAYLIGHT OPENING

FRANK BENNARDO, P.E.
 PE# 0046549 CA 9885



FL#29520.4

ENGINEERING EXPRESS
 CORPORATE OFFICE:
 160 SW 12th AVE, SUITE 106
 DEERFIELD BEACH, FL 33442
 (954) 354-0660 | (866) 396-9999
 TEAM@ENGINEERINGEXPRESS.COM
 ENGINEERINGEXPRESS.COM

CRAWFORD TRACEY CORPORATION
 3301 S.W. 13th DRIVE
 DEERFIELD BEACH, FL, 33442-8101
 Phn. (954) 698-6888
 PRO-TECH 455G ALUMINUM CURTAINWALL SYSTEM
 FLORIDA STATE APPROVAL

REMARKS	DATE	CHKD	DATE
FBC 2020 UPDATE	10/19/20	JEM	AJP

THIS DOCUMENT IS THE PROPERTY OF ENGINEERING EXPRESS, AND SHALL NOT BE REPRODUCED IN WHOLE OR PART WITHOUT WRITTEN CONSENT OF ENGINEERING EXPRESS. ALTERATIONS, ADDITIONS, OR OTHER MARKINGS TO THIS DOCUMENT ARE NOT PERMITTED AND INVALIDATE OUR CERTIFICATION.

COPYRIGHT ENGINEERING EXPRESS

20-32267

SCALE: NTS UNLESS NOTED

04

GLASS TYPE D - LOADING CHART (L.M.I.)

48 (in.)		
SIDE A OR B (D.L.O.) (in.)		
SIDE A OR B (D.L.O.) (in.)	(+) P.S.F	(-) P.S.F
36	80	80
42	80	80
48	80	80
54	80	80
60	80	80
66	80	80
72	80	80
78	80	80

60 (in.)		
SIDE A OR B (D.L.O.) (in.)		
SIDE A OR B (D.L.O.) (in.)	(+) P.S.F	(-) P.S.F
36	80	80
42	80	80
48	80	80
54	80	80
60	78	78

72 (in.)		
SIDE A OR B (D.L.O.) (in.)		
SIDE A OR B (D.L.O.) (in.)	(+) P.S.F	(-) P.S.F
36	80	80
42	80	80
48	80	80
54	80	80

84 (in.)		
SIDE A OR B (D.L.O.) (in.)		
SIDE A OR B (D.L.O.) (in.)	(+) P.S.F	(-) P.S.F
36	80	80
42	80	80

96.00 (in.)		
SIDE A OR B (D.L.O.) (in.)		
SIDE A OR B (D.L.O.) (in.)	(+) P.S.F	(-) P.S.F
36	80	80

108 (in.)		
SIDE A OR B (D.L.O.) (in.)		
SIDE A OR B (D.L.O.) (in.)	(+) P.S.F	(-) P.S.F
36	80	80

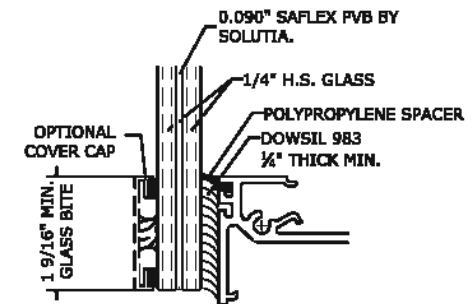

GLASS TYPE **D**
GLAZING DETAIL
 N.T.S.
GLASS RATING:
 LARGE MISSILE LEVEL D
 3/8\"/>

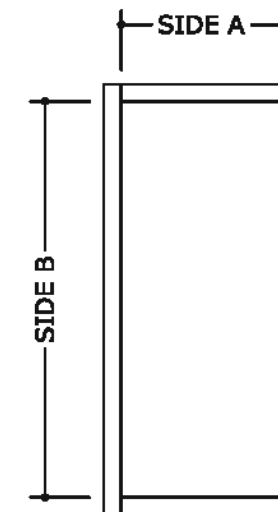

D.L.O. = DAYLIGHT OPENING

FRANK BENNARDO, P.E.
 PE# 0046549 CA 9885



FL#29520.4

ENGINEERING EXPRESS
 CORPORATE OFFICE:
 160 SW 12th AVE, SUITE 106
 DEERFIELD BEACH, FL 33442
 (954) 354-0660 | (866) 396-9999
 TEAM@ENGINEERINGEXPRESS.COM
 ENGINEERINGEXPRESS.COM

CRAWFORD TRACEY CORPORATION

3301 S.W. 13th DRIVE
 DEERFIELD BEACH, FL, 33442-8101
 Phn. (954) 698-6888

PRO-TECH 455G ALUMINUM CURTAINWALL SYSTEM
 FLORIDA STATE APPROVAL

REMARKS	DATE	CHKD	DATE
FBC 2020 UPDATE	10/19/20	JEM	AJP

THIS DOCUMENT IS THE PROPERTY OF ENGINEERING EXPRESS, AND SHALL NOT BE REPRODUCED IN WHOLE OR PART, WITHOUT WRITTEN CONSENT OF ENGINEERING EXPRESS. ALTERATIONS, ADDITIONS, OR OTHER MARKINGS TO THIS DOCUMENT ARE NOT PERMITTED AND INVALIDATE OUR CERTIFICATION.

COPYRIGHT ENGINEERING EXPRESS

20-32267

SCALE: NTS UNLESS NOTED

05



GLASS TYPE H, I, J - LOADING CHART (L.M.I.)

FRANK BENNARDO, P.E.
PE# 0046549 CA 9885



FL#29520.4

ENGINEERING EXPRESS
CORPORATE OFFICE:
160 SW 12th AVE, SUITE 106
DEERFIELD BEACH, FL 33442
(954) 354-0660 | (866) 396-9999
TEAM@ENGINEERINGEXPRESS.COM
ENGINEERINGEXPRESS.COM

60 (In.)		
SIDE A OR B (D.L.O.) (In.)		
SIDE A OR B (D.L.O.) (In.)	(+) P.S.F	(-) P.S.F
36	100	100
42	100	100
48	93	93
54	83	83
60	75	75
66	75	75
72	75	75
78	75	75
84	75	75

72 (In.)		
SIDE A OR B (D.L.O.) (In.)		
SIDE A OR B (D.L.O.) (In.)	(+) P.S.F	(-) P.S.F
36	100	155
42	100	155
48	93	155
54	83	83
60	75	75
66	68	68
72	62	62

84 (In.)		
SIDE A OR B (D.L.O.) (In.)		
SIDE A OR B (D.L.O.) (In.)	(+) P.S.F	(-) P.S.F
36	100	155
42	100	155
48	93	93
54	83	83
60	75	75

96 (In.)		
SIDE A OR B (D.L.O.) (In.)		
SIDE A OR B (D.L.O.) (In.)	(+) P.S.F	(-) P.S.F
36	100	155
42	100	100
48	93	93
54	83	83

108.00 (In.)		
SIDE A OR B (D.L.O.) (In.)		
SIDE A OR B (D.L.O.) (In.)	(+) P.S.F	(-) P.S.F
36	100	100
42	100	100
48	93	93

120 (In.)		
SIDE A OR B (D.L.O.) (In.)		
SIDE A OR B (D.L.O.) (In.)	(+) P.S.F	(-) P.S.F
36	100	100
42	100	100

132 (In.)		
SIDE A OR B (D.L.O.) (In.)		
WIDTH (In.)	(+) P.S.F	(-) P.S.F
36	100	100

144 (In.)		
SIDE A OR B (D.L.O.) (In.)		
WIDTH (In.)	(+) P.S.F	(-) P.S.F
36	100	100

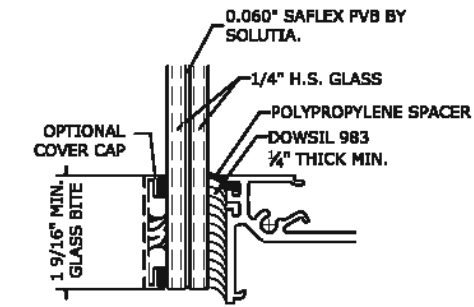

GLASS TYPE H
GLAZING DETAIL
N.T.S.
GLASS RATING:
LARGE MISSILE LEVEL D
3/8" GLASS

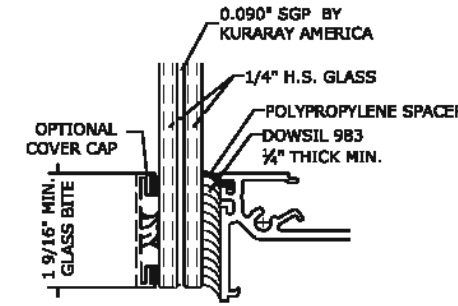

GLASS TYPE I
GLAZING DETAIL
N.T.S.
GLASS RATING:
LARGE MISSILE LEVEL D
3/8" GLASS

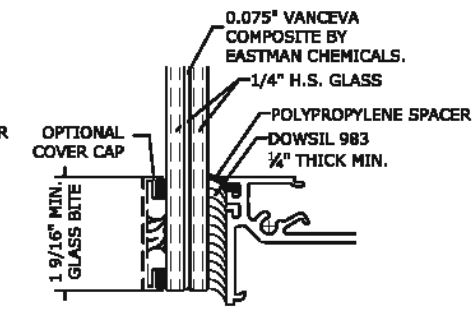

GLASS TYPE J
GLAZING DETAIL
N.T.S.
GLASS RATING:
LARGE MISSILE LEVEL D
3/8" GLASS

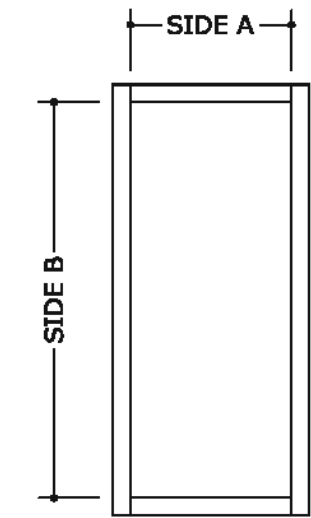

D.L.O. = DAYLIGHT OPENING

CRAWFORD TRACEY CORPORATION
3301 S.W. 13th DRIVE
DEERFIELD BEACH, FL, 33442-8101
Phn. (954) 698-6888
PRO-TECH 455G ALUMINUM CURTAINWALL SYSTEM
FLORIDA STATE APPROVAL

REMARKS	DATE	CHKD	DATE
FBC 2020 UPDATE	10/19/20	JEM	AJP

THIS DOCUMENT IS THE PROPERTY OF ENGINEERING EXPRESS, AND SHALL NOT BE REPRODUCED IN WHOLE OR PART, WITHOUT WRITTEN CONSENT OF ENGINEERING EXPRESS. ALTERATIONS, ADDITIONS, OR OTHER MARKINGS TO THIS DOCUMENT ARE NOT PERMITTED AND INVALIDATE OUR CERTIFICATION.

COPYRIGHT ENGINEERING EXPRESS

20-32267

SCALE: NTS UNLESS NOTED

06

GLASS TYPE K - LOADING CHART (L.M.I.)

72 (in.)		
SIDE A OR B (D.L.O.) (in.)		
SIDE A OR B (D.L.O.) (in.)	(+) P.S.F	(-) P.S.F
36	100	100
42	100	100
48	100	100
54	92	92
60	83	83
66	75	75
72	69	69
78	69	69

84 (in.)		
SIDE A OR B (D.L.O.) (in.)		
SIDE A OR B (D.L.O.) (in.)	(+) P.S.F	(-) P.S.F
36	100	100
42	100	100
48	100	100
54	92	92
60	83	83
66	75	75

96 (in.)		
SIDE A OR B (D.L.O.) (in.)		
SIDE A OR B (D.L.O.) (in.)	(+) P.S.F	(-) P.S.F
36	100	100
42	100	100
48	100	100
54	92	92
60	83	83

108.00 (in.)		
SIDE A OR B (D.L.O.) (in.)		
SIDE A OR B (D.L.O.) (in.)	(+) P.S.F	(-) P.S.F
36	100	100
42	100	100
48	100	100
54	92	92

120 (in.)		
SIDE A OR B (D.L.O.) (in.)		
SIDE A OR B (D.L.O.) (in.)	(+) P.S.F	(-) P.S.F
36	100	100
42	100	100
48	100	100

132 (in.)		
SIDE A OR B (D.L.O.) (in.)		
SIDE A OR B (D.L.O.) (in.)	(+) P.S.F	(-) P.S.F
36	100	100
42	100	100

144 (in.)		
SIDE A OR B (D.L.O.) (in.)		
SIDE A OR B (D.L.O.) (in.)	(+) P.S.F	(-) P.S.F
36	100	100

156 (in.)		
SIDE A OR B (D.L.O.) (in.)		
SIDE A OR B (D.L.O.) (in.)	(+) P.S.F	(-) P.S.F
36	100	100

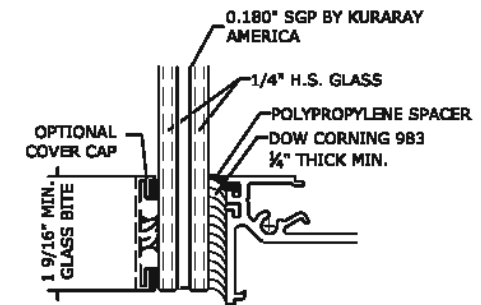

GLASS TYPE 
GLAZING DETAIL
 N.T.S.
GLASS RATING:
 LARGE MISSILE LEVEL E
 3/8" GLASS

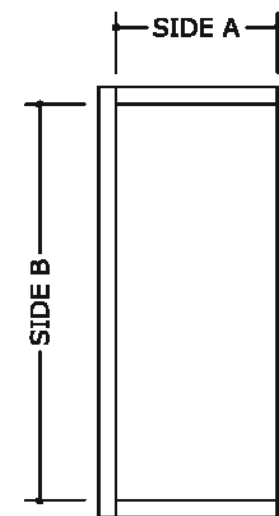

D.L.O. = DAYLIGHT OPENING

FRANK BENNARDO, P.E.
 PE# 0046549 CA 9885



FL#29520.4

ENGINEERING EXPRESS
 CORPORATE OFFICE:
 160 SW 12th AVE, SUITE 106
 DEERFIELD BEACH, FL 33442
 (954) 354-0660 | (866) 396-9999
 TEAM@ENGINEERINGEXPRESS.COM
 ENGINEERINGEXPRESS.COM

CRAWFORD TRACEY CORPORATION

3301 S.W. 13th DRIVE
 DEERFIELD BEACH, FL, 33442-8101
 Phn. (954) 698-6888

PRO-TECH 455G ALUMINUM CURTAINWALL SYSTEM
 FLORIDA STATE APPROVAL

REMARKS	DATE	CHKD	DATE
FBC 2020 UPDATE	10/19/20	JEM	AJP

THIS DOCUMENT IS THE PROPERTY OF ENGINEERING EXPRESS, AND SHALL NOT BE REPRODUCED IN WHOLE OR PART, WITHOUT WRITTEN CONSENT OF ENGINEERING EXPRESS. ALTERATIONS, ADDITIONS, OR OTHER MARKINGS TO THIS DOCUMENT ARE NOT PERMITTED AND INVALIDATE OUR CERTIFICATION.

COPYRIGHT ENGINEERING EXPRESS

20-32267

SCALE: NTS UNLESS NOTED

07 

GLASS TYPE L - LOADING CHART (L.M.I.)

60 (In.)		
HEIGHT		
WIDTH (In.)	(+) P.S.F	(-) P.S.F
24	80	80
30	80	80
36	80	80
42	68	68
48	60	60
54	53	53
60	48	48
66	48	48

72 (In.)		
HEIGHT		
WIDTH (In.)	(+) P.S.F	(-) P.S.F
24	80	80
30	80	80
36	80	80
42	68	68
48	60	60
54	53	53

84 (In.)		
HEIGHT		
WIDTH (In.)	(+) P.S.F	(-) P.S.F
24	80	80
30	80	80
36	80	80
42	68	68
48	60	60

96 (In.)		
HEIGHT		
WIDTH (In.)	(+) P.S.F	(-) P.S.F
24	80	80
30	80	80
36	80	80
42	68	68

108 (In.)		
HEIGHT		
WIDTH (In.)	(+) P.S.F	(-) P.S.F
24	80	80
30	80	80
36	80	80

96 (In.)		
HEIGHT		
WIDTH (In.)	(+) P.S.F	(-) P.S.F
24	80	80
30	80	80

120 (In.)		
HEIGHT		
WIDTH (In.)	(+) P.S.F	(-) P.S.F
24	80	80
30	80	80

132 (In.)		
HEIGHT		
WIDTH (In.)	(+) P.S.F	(-) P.S.F
24	80	80
30	80	80

144 (In.)		
HEIGHT		
WIDTH (In.)	(+) P.S.F	(-) P.S.F
24	80	80

156 (In.)		
HEIGHT		
WIDTH (In.)	(+) P.S.F	(-) P.S.F
24	80	80

162 (In.)		
HEIGHT		
WIDTH (In.)	(+) P.S.F	(-) P.S.F
24	80	80

174 (In.)		
HEIGHT		
WIDTH (In.)	(+) P.S.F	(-) P.S.F
24	80	80

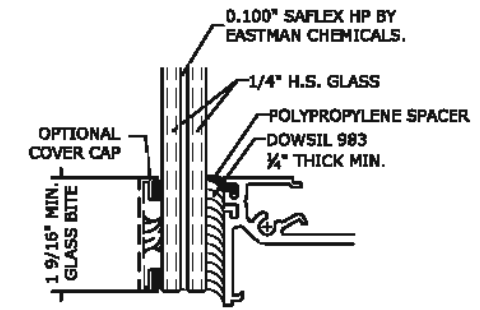

GLASS TYPE 
GLAZING DETAIL
 N.T.S.
GLASS RATING:
 LARGE MISSILE LEVEL D
 3/8" GLASS

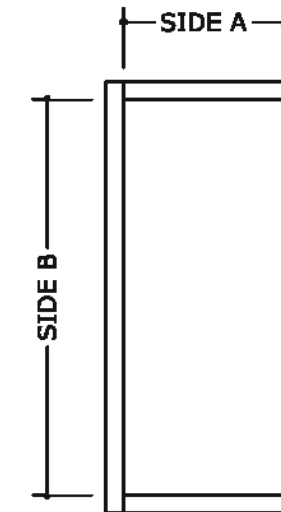

D.L.O. = DAYLIGHT OPENING

FRANK BENNARDO, P.E.
 PE# 0046549 CA 9885



FL#29520.4

ENGINEERING EXPRESS
 CORPORATE OFFICE:
 160 SW 12th AVE, SUITE 106
 DEERFIELD BEACH, FL 33442
 (954) 354-0660 | (866) 396-9999
 TEAM@ENGINEERINGEXPRESS.COM
 ENGINEERINGEXPRESS.COM

CRAWFORD TRACEY CORPORATION

3301 S.W. 13th DRIVE
 DEERFIELD BEACH, FL, 33442-8101
 Phn. (954) 698-6888

PRO-TECH 455G ALUMINUM CURTAINWALL SYSTEM
 FLORIDA STATE APPROVAL

REMARKS	DATE	CHKD	DATE
FBC 2020 UPDATE	10/19/20	JEM	AJP

THIS DOCUMENT IS THE PROPERTY OF ENGINEERING EXPRESS, AND SHALL NOT BE REPRODUCED IN WHOLE OR PART, WITHOUT WRITTEN CONSENT OF ENGINEERING EXPRESS. ALTERATIONS, ADDITIONS, OR OTHER MARKINGS TO THIS DOCUMENT ARE NOT PERMITTED AND INVALIDATE OUR CERTIFICATION.

COPYRIGHT ENGINEERING EXPRESS®

20-32267

SCALE: NTS UNLESS NOTED

08



GLASS TYPE B1, C1, D1 - LOADING CHART (L.M.I.)

60 (in.)		
HEIGHT		
WIDTH (in.)	(+) P.S.F.	(-) P.S.F.
24	100	100
30	100	100
36	100	100
42	100	100
48	100	100
54	100	100
60	95	95
66	95	95
72	95	95
78	95	95
84	95	95

72 (in.)		
HEIGHT		
WIDTH (in.)	(+) P.S.F.	(-) P.S.F.
24	100	100
30	100	100
36	100	100
42	100	100
48	100	100
54	100	100
60	95	95
66	86	86
72	79	79

84 (in.)		
HEIGHT		
WIDTH (in.)	(+) P.S.F.	(-) P.S.F.
24	100	100
30	100	100
36	100	100
42	100	100
48	100	100
54	100	100
60	95	95

96.00 (in.)		
HEIGHT		
WIDTH (in.)	(+) P.S.F.	(-) P.S.F.
24	100	100
30	100	100
36	100	100
42	100	100
48	100	100
54	100	100

108 (in.)		
HEIGHT		
WIDTH (in.)	(+) P.S.F.	(-) P.S.F.
24	100	100
30	100	100
36	100	100
42	100	100
48	100	100

120 (in.)		
HEIGHT		
WIDTH (in.)	(+) P.S.F.	(-) P.S.F.
24	100	100
30	100	100
36	100	100
42	100	100
48	100	100

132 (in.)		
HEIGHT		
WIDTH (in.)	(+) P.S.F.	(-) P.S.F.
24	100	100
30	100	100
36	100	100

144 (in.)		
HEIGHT		
WIDTH (in.)	(+) P.S.F.	(-) P.S.F.
24	100	100
30	100	100
36	100	100

156 (in.)		
HEIGHT		
WIDTH (in.)	(+) P.S.F.	(-) P.S.F.
24	100	100
30	100	100

168 (in.)		
HEIGHT		
WIDTH (in.)	(+) P.S.F.	(-) P.S.F.
24	100	100
30	100	100

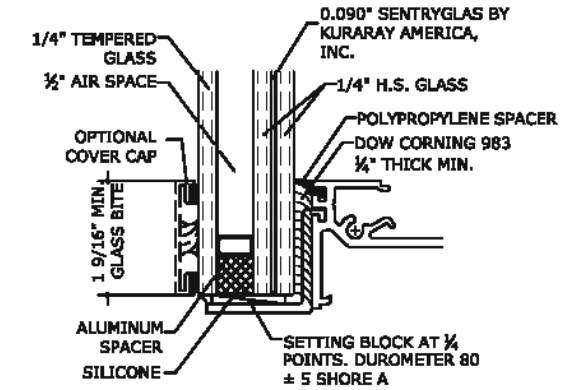

GLASS TYPE B1
GLAZING DETAIL
 N.T.S.
GLASS RATING:
 LARGE MISSILE LEVEL D
 1 3/8" GLASS

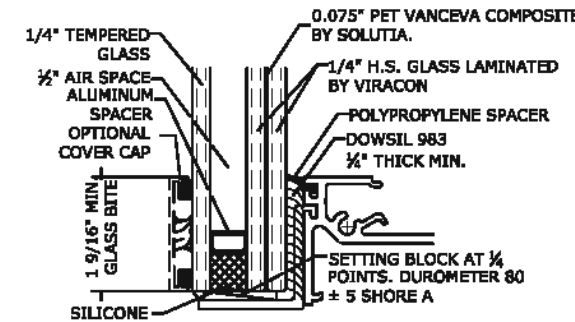

GLASS TYPE C1
GLAZING DETAIL
 N.T.S.
GLASS RATING:
 LARGE MISSILE LEVEL E
 1 3/8" GLASS

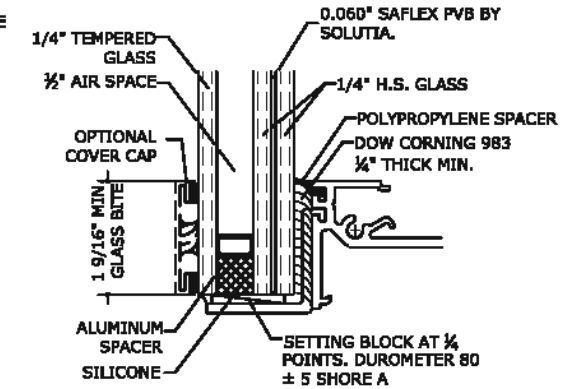

GLASS TYPE D1
GLAZING DETAIL
 N.T.S.
GLASS RATING:
 LARGE MISSILE LEVEL D
 1 3/8" GLASS

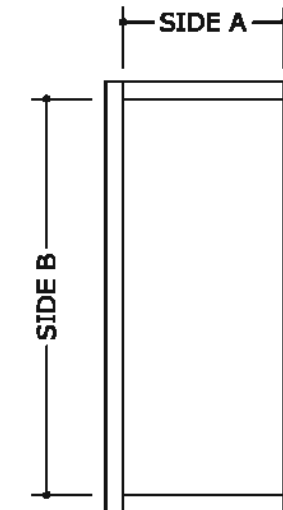

D.L.O. = DAYLIGHT OPENING

FRANK BENNARDO, P.E.
 PE# 0046549 CA 9885



FL#29520.4

ENGINEERING EXPRESS
 CORPORATE OFFICE:
 160 SW 12th AVE, SUITE 106
 DEERFIELD BEACH, FL 33442
 (954) 354-0660 | (866) 396-9999
 TEAM@ENGINEERINGEXPRESS.COM
 ENGINEERINGEXPRESS.COM

CRAWFORD TRACEY CORPORATION
 3301 S.W. 13th DRIVE
 DEERFIELD BEACH, FL, 33442-8101
 Phn. (954) 698-6888
PRO-TECH 455G ALUMINUM CURTAINWALL SYSTEM
 FLORIDA STATE APPROVAL

REMARKS	DATE	CHKD	DATE
FBC 2020 UPDATE	10/19/20	JEM	AJP

THIS DOCUMENT IS THE PROPERTY OF ENGINEERING EXPRESS, AND SHALL NOT BE REPRODUCED IN WHOLE OR PART, WITHOUT WRITTEN CONSENT OF ENGINEERING EXPRESS. ALTERATIONS, ADDITIONS, OR OTHER MARKINGS TO THIS DOCUMENT ARE NOT PERMITTED AND INVALIDATE OUR CERTIFICATION.

COPYRIGHT ENGINEERING EXPRESS®

20-32267

SCALE: NTS UNLESS NOTED

09

GLASS TYPE E1 - LOADING CHART (L.M.I.)

FRANK BENNARDO, P.E.
PE# 0046549 CA 9885



FL#29520.4

ENGINEERING EXPRESS
CORPORATE OFFICE:
160 SW 12th AVE, SUITE 106
DEERFIELD BEACH, FL 33442
(954) 354-0660 | (866) 396-9999
TEAM@ENGINEERINGEXPRESS.COM
ENGINEERINGEXPRESS.COM

60 (in.)		
HEIGHT		
WIDTH (in.)	(+) P.S.F	(-) P.S.F
24	100	100
30	100	100
36	100	100
42	100	100
48	100	100
54	100	100
60	95	95
66	95	95
72	95	95
78	95	95
84	95	95

72 (in.)		
HEIGHT		
WIDTH (in.)	(+) P.S.F	(-) P.S.F
24	100	100
30	100	100
36	100	100
42	100	100
48	100	100
54	100	100
60	95	95
66	86	86
72	79	79

84 (in.)		
HEIGHT		
WIDTH (in.)	(+) P.S.F	(-) P.S.F
24	100	100
30	100	100
36	100	100
42	100	100
48	100	100
54	100	100
60	95	95

96.00 (in.)		
HEIGHT		
WIDTH (in.)	(+) P.S.F	(-) P.S.F
24	100	100
30	100	100
36	100	100
42	100	100
48	100	100
54	100	100

108 (in.)		
HEIGHT		
WIDTH (in.)	(+) P.S.F	(-) P.S.F
24	100	100
30	100	100
36	100	100
42	100	100
48	100	100

120 (in.)		
HEIGHT		
WIDTH (in.)	(+) P.S.F	(-) P.S.F
24	100	100
30	100	100
36	100	100
42	100	100

132 (in.)		
HEIGHT		
WIDTH (in.)	(+) P.S.F	(-) P.S.F
24	100	100
30	100	100
36	100	100

144 (in.)		
HEIGHT		
WIDTH (in.)	(+) P.S.F	(-) P.S.F
24	100	100
30	100	100
36	100	100

156 (in.)		
HEIGHT		
WIDTH (in.)	(+) P.S.F	(-) P.S.F
24	100	100
30	100	100

168 (in.)		
HEIGHT		
WIDTH (in.)	(+) P.S.F	(-) P.S.F
24	100	100
30	100	100

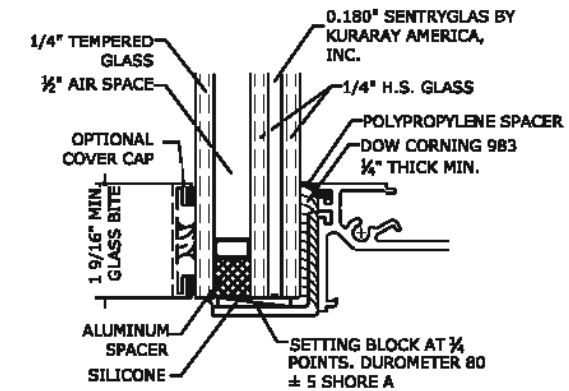

GLASS TYPE **E1**
 GLAZING DETAIL
 N.T.S.
 GLASS RATING:
 LARGE MISSILE LEVEL E
 1 1/8" GLASS

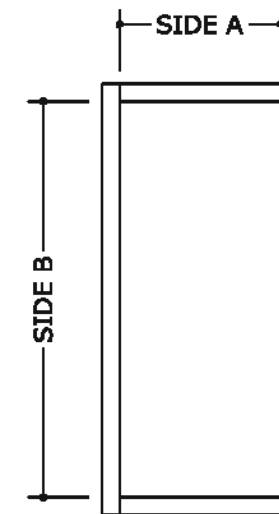

D.L.O. = DAYLIGHT OPENING

CRAWFORD TRACEY CORPORATION
 3301 S.W. 13th DRIVE
 DEERFIELD BEACH, FL, 33442-8101
 Phn. (954) 698-6888
 PRO-TECH 455G ALUMINUM CURTAINWALL SYSTEM
 FLORIDA STATE APPROVAL

REMARKS	DRWN	CHKD	DATE
FBC 2020 UPDATE	JEM	AJP	10/19/20

THIS DOCUMENT IS THE PROPERTY OF ENGINEERING EXPRESS, AND SHALL NOT BE REPRODUCED IN WHOLE OR PART, WITHOUT WRITTEN CONSENT OF ENGINEERING EXPRESS. ALTERATIONS, ADDITIONS, OR OTHER MARKINGS TO THIS DOCUMENT ARE NOT PERMITTED AND INVALIDATE OUR CERTIFICATION.

COPYRIGHT ENGINEERING EXPRESS

20-32267

SCALE: NTS UNLESS NOTED

10

GLASS TYPES (S.M.I.)

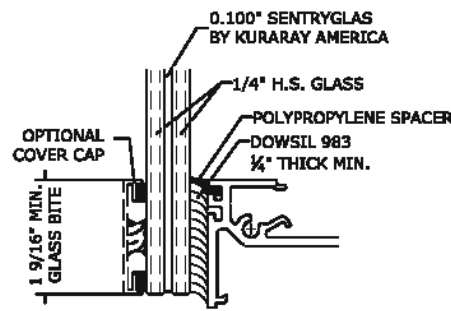

GLASS TYPE A
GLAZING DETAIL

N.T.S.
GLASS RATING:
SMALL MISSILE IMPACT
1/8" GLASS

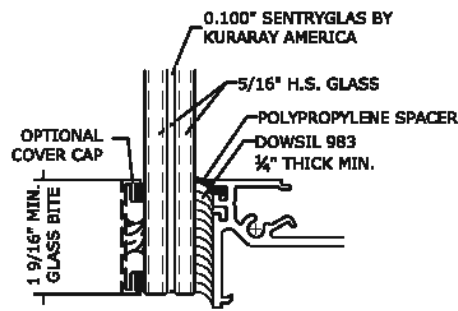

GLASS TYPE B
GLAZING DETAIL

N.T.S.
GLASS RATING:
LARGE MISSILE LEVEL D
1/8" GLASS

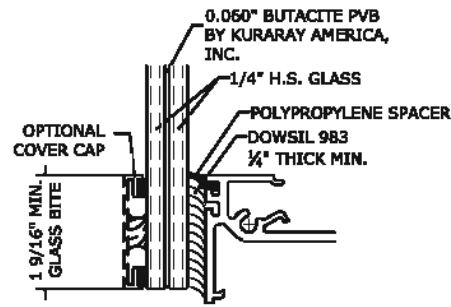

GLASS TYPE C
GLAZING DETAIL

N.T.S.
GLASS RATING:
SMALL MISSILE IMPACT
1/8" GLASS

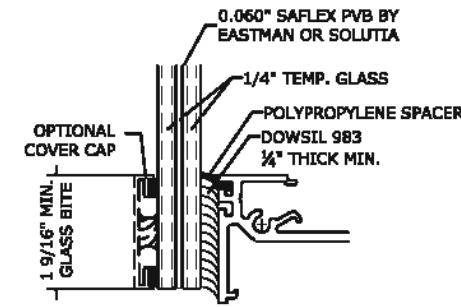

GLASS TYPE E
GLAZING DETAIL

N.T.S.
GLASS RATING:
SMALL MISSILE IMPACT
1/8" GLASS

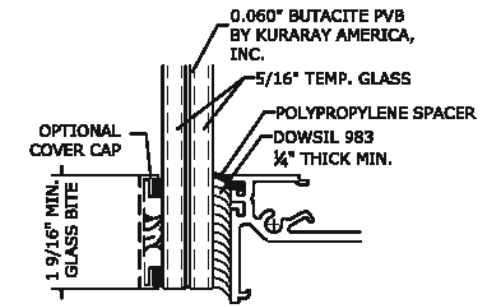

GLASS TYPE F
GLAZING DETAIL

N.T.S.
GLASS RATING:
SMALL MISSILE IMPACT
1/8" GLASS

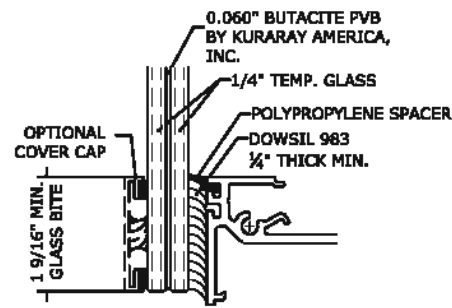

GLASS TYPE G
GLAZING DETAIL

N.T.S.
GLASS RATING:
SMALL MISSILE IMPACT
1/8" GLASS

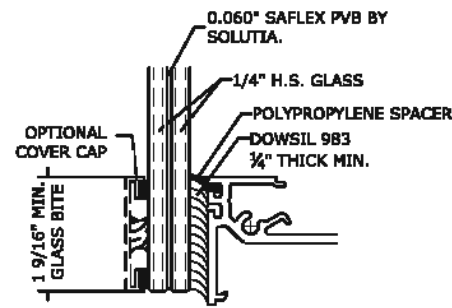

GLASS TYPE H
GLAZING DETAIL

N.T.S.
GLASS RATING:
SMALL MISSILE IMPACT
1/8" GLASS

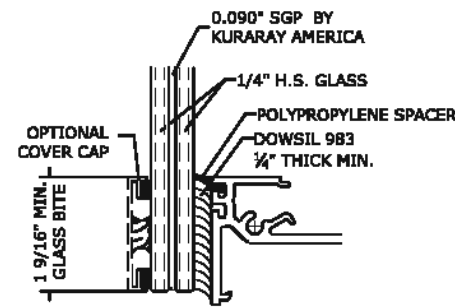

GLASS TYPE I
GLAZING DETAIL

N.T.S.
GLASS RATING:
SMALL MISSILE IMPACT
1/8" GLASS

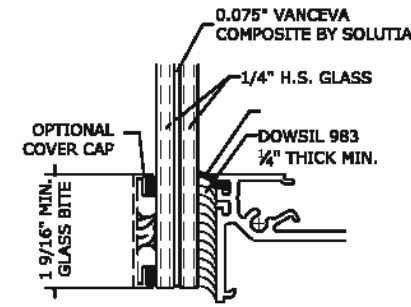

GLASS TYPE J
GLAZING DETAIL

N.T.S.
GLASS RATING:
SMALL MISSILE IMPACT
1/8" GLASS

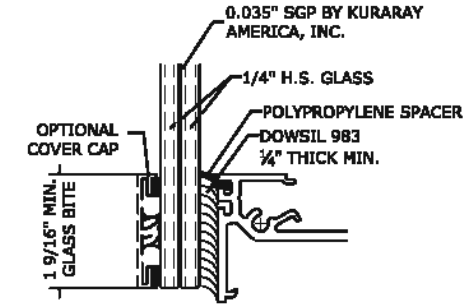

GLASS TYPE M
GLAZING DETAIL

N.T.S.
GLASS RATING:
SMALL MISSILE IMPACT
1 1/8" GLASS

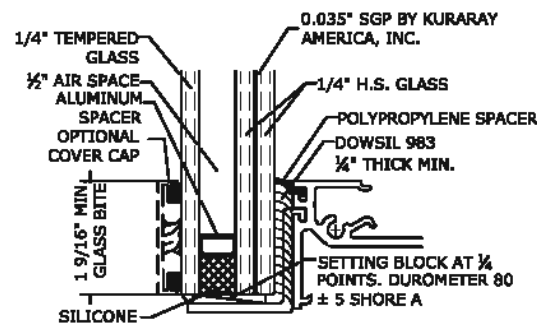

GLASS TYPE AI
GLAZING DETAIL

N.T.S.
GLASS RATING:
SMALL MISSILE IMPACT
1 1/8" GLASS

NOTES:

THICKER GLASS LITES MAY BE USED IN THE SAME CONFIGURATIONS AS SHOWN ABOVE, AS REQUIRED ON A SITE SPECIFIC BASIS. IF THICKER LITES ARE USED, IT SHALL BE CHECKED AND APPROVED BY A PROFESSIONAL ENGINEER.

CURVED OR BENT GLAZING MAY BE USED IN THE SAME CONFIGURATIONS AS SHOWN ABOVE, IN ACCORDANCE WITH SITE SPECIFIC REQUIREMENTS. IF CURVED OR BENT GLAZING IS USED, IT SHALL BE CHECKED AND APPROVED BY A PROFESSIONAL ENGINEER AND THE MANUFACTURER. FINAL APPROVAL SHALL BE GIVEN BY STATE AUTHORITY HAVING JURISDICTION.

NON-LAMINATED, MONOLITHIC GLASS MAY BE USED IN PLACE OF THE LAMINATED OPTIONS, SHOWN ON PAGE ABOVE, GIVEN THAT THE GLASS TO BE USED IS LABELED AS "NON-IMPACT RESISTANT" AND IS DESIGNED TO MEET ASTM E-1300 STANDARDS. THE SUBSTITUTED GLAZING MUST BE CHECKED AND APPROVED BY A PROFESSIONAL ENGINEER AND THE MANUFACTURER

NOTES:

- GLAZED GEOMETRICAL SHAPES MAY BE USED PROVIDED THEY FIT INSIDE THE APPROVED INSCRIBED SIZES.
- GLAZING DETAILS WITH A SILICONE BITE OF 1 1/8" ARE PERMITTED TO BE DECREASED TO A MINIMUM OF 1 3/8" SILICONE BITE, PROVIDED THE ALLOWABLE PRESSURES SHOWN ON GLASS CHARTS ARE DECREASED BY 16%
- OPTION OF .019" CERAMIC FRIT ON ROOM SIDE SURFACE OF INNER PANE GLASS
- GLASS MAY BE VERTICALLY OR HORIZONTALLY ORIENTED
- OPTIONAL GLASS CAPS, FINS, OR SIMILAR ACCESORIES OF VARIOUS SIZES MAY BE ATTACHED WITH SILICONE, BASED ON SITE SPECIFIC CALCULATIONS
- CONDITIONS WHERE THE GLASS EXTENDS PAST THE FRAME ARE ALLOWED AS LONG AS THE GLASS IS SUPPORTED BY A STRUCTURALLY SOUND SUBSTRATE. THIS CONDITION SHALL REQUIRE APPROVAL BY A PROFESSIONAL ENGINEER.
- NON IMPACT GLASS TO BE DESIGNED ON A SITE SPECIFIC BASIS AND APPROVED BY A PROFESSIONAL ENGINEER.
- GLASS PLIES NOT IN CONTACT WITH STRUCTURAL SILICONE MAYBE A GREATER THICKNESS THAN THOSE SHOWN, AND SHALL BE CHECKED AND APPROVED BY THE MANUFACTURER AND PROFESSIONAL ENGINEER ON A SITE SPECIFIC BASIS.

FRANK BENNARDO, P.E.
PE# 0046549 CA 9885



FL#29520.4

ENGINEERING EXPRESS
CORPORATE OFFICE:
160 SW 12th AVE, SUITE 106
DEERFIELD BEACH, FL 33442
(954) 354-0660 | (866) 996-9999
TEAM@ENGINEERINGEXPRESS.COM
ENGINEERINGEXPRESS.COM

CRAWFORD TRACEY CORPORATION

3301 S.W. 13th DRIVE
DEERFIELD BEACH, FL, 33442-8101
Phn. (954) 698-6888

PRO-TECH 455G ALUMINUM CURTAINWALL SYSTEM
FLORIDA STATE APPROVAL

REMARKS	DATE	DRWN	CHKD
FBC 2020 UPDATE	10/19/20	JEM	AJP

THIS DOCUMENT IS THE PROPERTY OF ENGINEERING EXPRESS, AND SHALL NOT BE REPRODUCED IN WHOLE OR PART WITHOUT WRITTEN CONSENT OF ENGINEERING EXPRESS. ALTERATIONS, ADDITIONS, OR OTHER MARKINGS TO THIS DOCUMENT ARE NOT PERMITTED AND INVALIDATE OUR CERTIFICATION.

COPYRIGHT ENGINEERING EXPRESS

20-32267

SCALE: NTS UNLESS NOTED

11

GLASS TYPE A & B - LOADING CHART (S.M.I.)

72 (in.)		
SIDE A OR B (D.L.O.) (in.)		
SIDE A OR B (D.L.O.) (in.)	(+) P.S.F	(-) P.S.F
36	120	126
42	120	126
48	120	126
54	120	126
60	120	126
66	111	117
72	102	107
78	102	107
84	102	107
90	102	107
96	102	107
102	102	107
108	102	107
114	102	107
120	102	107
126	102	107
132	102	107
138	102	107
144	102	107
150	102	107
156	102	107
162	102	107

84 (in.)		
SIDE A OR B (D.L.O.) (in.)		
SIDE A OR B (D.L.O.) (in.)	(+) P.S.F	(-) P.S.F
36	120	126
42	120	126
48	120	126
54	120	126
60	120	126
66	111	117
72	102	107
78	94	99
84	87	92
90	87	92
96	87	92
102	87	92
108	87	92
114	87	92
120	87	92
126	87	92
132	87	92
138	87	92

96 (in.)		
SIDE A OR B (D.L.O.) (in.)		
SIDE A OR B (D.L.O.) (in.)	(+) P.S.F	(-) P.S.F
36	120	126
42	120	126
48	120	126
54	120	126
60	120	126
66	111	117
72	102	107
78	94	99
84	87	92
90	82	86
96	76	80
102	76	80
108	76	80
114	76	80
120	76	80

108.00 (in.)		
SIDE A OR B (D.L.O.) (in.)		
SIDE A OR B (D.L.O.) (in.)	(+) P.S.F	(-) P.S.F
36	120	126
42	120	126
48	120	126
54	120	126
60	120	126
66	111	117
72	102	107
78	94	99
84	87	92
90	82	86
96	76	80
102	72	75
108	68	71

120 (in.)		
SIDE A OR B (D.L.O.) (in.)		
SIDE A OR B (D.L.O.) (in.)	(+) P.S.F	(-) P.S.F
36	120	126
42	120	126
48	120	126
54	120	126
60	120	126
66	111	117
72	102	107
78	94	99
84	87	92
90	82	86
96	76	80

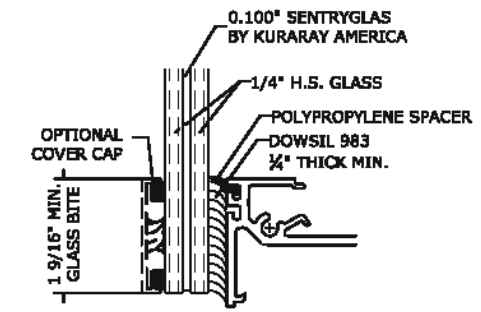

GLASS TYPE A
GLAZING DETAIL
 N.T.S.
GLASS RATING:
 SMALL MISSILE IMPACT
 3/8" GLASS

132 (in.)		
SIDE A OR B (D.L.O.) (in.)		
WIDTH (in.)	(+) P.S.F	(-) P.S.F
36	120	126
42	120	126
48	120	126
54	120	126
60	120	126
66	111	117
72	102	107
78	94	99
84	87	92

144 (in.)		
SIDE A OR B (D.L.O.) (in.)		
WIDTH (in.)	(+) P.S.F	(-) P.S.F
36	120	126
42	120	126
48	120	126
54	120	126
60	120	126
66	111	117
72	102	107
78	94	99

156 (in.)		
SIDE A OR B (D.L.O.) (in.)		
WIDTH (in.)	(+) P.S.F	(-) P.S.F
36	120	126
42	120	126
48	120	126
54	120	126
60	120	126
66	111	117
72	102	107

168.00 (in.)		
SIDE A OR B (D.L.O.) (in.)		
SIDE A OR B (D.L.O.) (in.)	(+) P.S.F	(-) P.S.F
36	120	126
42	120	126
48	120	126
54	120	126
60	120	126
66	111	117

180 (in.)		
SIDE A OR B (D.L.O.) (in.)		
SIDE A OR B (D.L.O.) (in.)	(+) P.S.F	(-) P.S.F
36	120	126
42	120	126
48	120	126
54	120	126
60	120	126
66	111	117

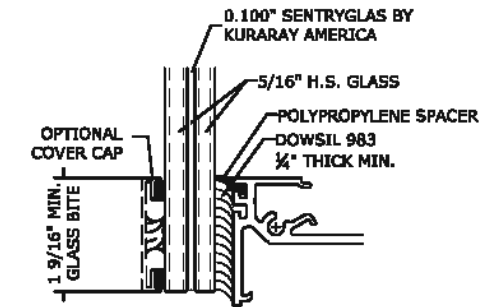

GLASS TYPE B
GLAZING DETAIL
 N.T.S.
GLASS RATING:
 LARGE MISSILE LEVEL D
 3/8" GLASS

192 (in.)		
SIDE A OR B (D.L.O.) (in.)		
WIDTH (in.)	(+) P.S.F	(-) P.S.F
36	120	126
42	120	126
48	120	126
54	120	126
60	120	126

198 (in.)		
SIDE A OR B (D.L.O.) (in.)		
WIDTH (in.)	(+) P.S.F	(-) P.S.F
36	120	126
42	120	126
48	120	126
54	120	126

204 (in.)		
SIDE A OR B (D.L.O.) (in.)		
WIDTH (in.)	(+) P.S.F	(-) P.S.F
36	120	126
42	120	126
48	120	126
54	120	126

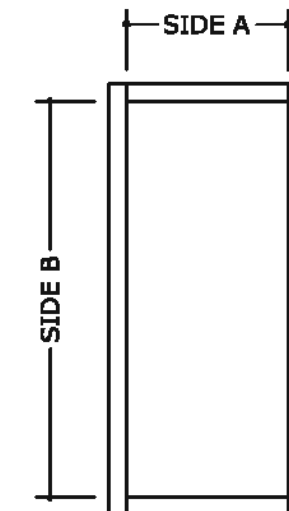

D.L.O. = DAYLIGHT OPENING

FRANK BENNARDO, P.E.
 PE# 0046549 CA 9885



FL#29520.4

ENGINEERING EXPRESS
 CORPORATE OFFICE:
 160 SW 12th AVE, SUITE 106
 DEERFIELD BEACH, FL 33442
 (954) 354-0660 | (866) 396-9999
 TEAM@ENGINEERINGEXPRESS.COM
 ENGINEERINGEXPRESS.COM

CRAWFORD TRACEY CORPORATION
 3301 S.W. 13th DRIVE
 DEERFIELD BEACH, FL, 33442-8101
 Phn. (954) 698-6888
PRO-TECH 455G ALUMINUM CURTAINWALL SYSTEM
 FLORIDA STATE APPROVAL

REMARKS	DATE	CHKD	DATE
FBC 2020 UPDATE	10/19/20	JEM	AJP

THIS DOCUMENT IS THE PROPERTY OF ENGINEERING EXPRESS, AND SHALL NOT BE REPRODUCED IN WHOLE OR PART WITHOUT WRITTEN CONSENT OF ENGINEERING EXPRESS. ALTERATIONS, ADDITIONS, OR OTHER MARKINGS TO THIS DOCUMENT ARE NOT PERMITTED AND INVALIDATE OUR CERTIFICATION.

COPYRIGHT ENGINEERING EXPRESS®

20-32267

SCALE: NTS UNLESS NOTED

12

GLASS TYPE C & F - LOADING CHART (S.M.I.)

72 (in.)		
SIDE A OR B (D.L.O.) (in.)		
SIDE A OR B (D.L.O.) (in.)	(+) P.S.F	(-) P.S.F
36	120	132
42	120	132
48	120	132
54	120	132
60	120	132
66	111	123
72	102	112
78	102	112
84	102	112
90	102	112
96	102	112
102	102	112
108	102	112
114	102	112
120	102	112
126	102	112
132	102	112
138	102	112
144	102	112
150	102	112
156	102	112
162	102	112
168	102	112
174	102	112

84 (in.)		
SIDE A OR B (D.L.O.) (in.)		
SIDE A OR B (D.L.O.) (in.)	(+) P.S.F	(-) P.S.F
36	120	132
42	120	132
48	120	132
54	120	132
60	120	132
66	111	123
72	102	112
78	94	104
84	87	96
90	87	96
96	87	96
102	87	96
108	87	96
114	87	96
120	87	96
126	87	96
132	87	96
138	87	96
144	87	96
150	87	96
156	87	96
162	87	96
168	87	96

96 (in.)		
SIDE A OR B (D.L.O.) (in.)		
SIDE A OR B (D.L.O.) (in.)	(+) P.S.F	(-) P.S.F
36	120	132
42	120	132
48	120	132
54	120	132
60	120	132
66	111	123
72	102	112
78	94	104
84	87	96
90	82	90
96	78	84
102	78	84
108	78	84
114	78	84
120	78	84
126	78	84
132	78	84
138	78	84
144	78	84
150	78	84

108.00 (in.)		
SIDE A OR B (D.L.O.) (in.)		
SIDE A OR B (D.L.O.) (in.)	(+) P.S.F	(-) P.S.F
36	120	132
42	120	132
48	120	132
54	120	132
60	120	132
66	111	123
72	102	112
78	94	104
84	87	96
90	82	90
96	78	84
102	72	79
108	68	75
114	68	75
120	68	75
126	68	75
132	68	75

120 (in.)		
SIDE A OR B (D.L.O.) (in.)		
SIDE A OR B (D.L.O.) (in.)	(+) P.S.F	(-) P.S.F
36	120	132
42	120	132
48	120	132
54	120	132
60	120	132
66	111	123
72	102	112
78	94	104
84	87	96
90	82	90
96	78	84
102	72	79
108	68	75
114	64	71
120	61	67

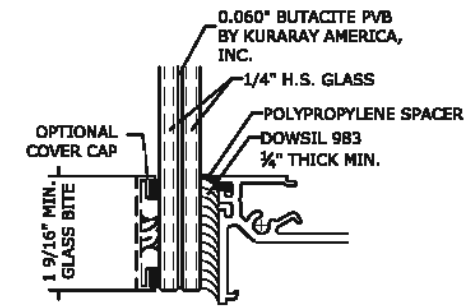

GLASS TYPE C
GLAZING DETAIL
 N.T.S.
GLASS RATING:
 SMALL MISSILE IMPACT
 1/8" GLASS

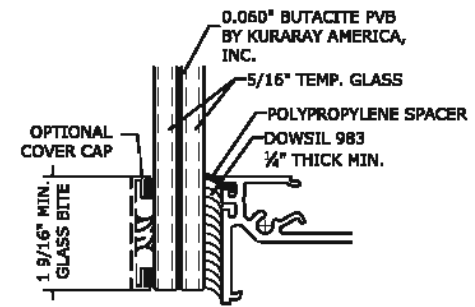

GLASS TYPE F
GLAZING DETAIL
 N.T.S.
GLASS RATING:
 SMALL MISSILE IMPACT
 1/8" GLASS

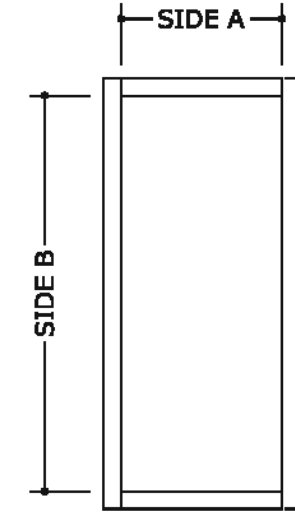

D.L.O. = DAYLIGHT OPENING

132 (in.)		
SIDE A OR B (D.L.O.) (in.)		
SIDE A OR B (D.L.O.) (in.)	(+) P.S.F	(-) P.S.F
36	120	132
42	120	132
48	120	132
54	120	132
60	120	132
66	111	123
72	102	112
78	94	104
84	87	96
90	82	90
96	76	84
102	72	78
108	68	75

144 (in.)		
SIDE A OR B (D.L.O.) (in.)		
SIDE A OR B (D.L.O.) (in.)	(+) P.S.F	(-) P.S.F
36	120	132
42	120	132
48	120	132
54	120	132
60	120	132
66	111	123
72	102	112
78	94	104
84	87	96
90	82	90
96	76	84

156 (in.)		
SIDE A OR B (D.L.O.) (in.)		
SIDE A OR B (D.L.O.) (in.)	(+) P.S.F	(-) P.S.F
36	120	132
42	120	132
48	120	132
54	120	132
60	120	132
66	111	123
72	102	112
78	94	104
84	87	96
90	82	90

168.00 (in.)		
SIDE A OR B (D.L.O.) (in.)		
SIDE A OR B (D.L.O.) (in.)	(+) P.S.F	(-) P.S.F
36	120	132
42	120	132
48	120	132
54	120	132
60	120	132
66	111	123
72	102	112
78	94	104
84	87	96

180 (in.)		
SIDE A OR B (D.L.O.) (in.)		
SIDE A OR B (D.L.O.) (in.)	(+) P.S.F	(-) P.S.F
36	120	132
42	120	132
48	120	132
54	120	132
60	120	132
66	111	123
72	102	112
78	94	104

192 (in.)		
SIDE A OR B (D.L.O.) (in.)		
SIDE A OR B (D.L.O.) (in.)	(+) P.S.F	(-) P.S.F
36	120	132
42	120	132
48	120	132
54	120	132
60	120	132
66	111	123
72	102	112

204 (in.)		
SIDE A OR B (D.L.O.) (in.)		
SIDE A OR B (D.L.O.) (in.)	(+) P.S.F	(-) P.S.F
36	120	132
42	120	132
48	120	132
54	120	132
60	120	132
66	111	123

216 (in.)		
SIDE A OR B (D.L.O.) (in.)		
SIDE A OR B (D.L.O.) (in.)	(+) P.S.F	(-) P.S.F
36	120	132
42	120	132
48	120	132
54	120	132
60	120	132
66	111	123

228 (in.)		
SIDE A OR B (D.L.O.) (in.)		
SIDE A OR B (D.L.O.) (in.)	(+) P.S.F	(-) P.S.F
36	120	132
42	120	132
48	120	132
54	120	132
60	120	132

240 (in.)		
SIDE A OR B (D.L.O.) (in.)		
SIDE A OR B (D.L.O.) (in.)	(+) P.S.F	(-) P.S.F
36	120	132
42	120	132
48	120	132
54	120	132
60	120	132

FRANK BENNARDO, P.E.
 PE# 0046549 CA 9885



FL#29520.4

ENGINEERING EXPRESS
 CORPORATE OFFICE:
 160 SW 12th AVE, SUITE 106
 DEERFIELD BEACH, FL 33442
 (954) 354-0660 | (866) 396-9999
 TEAM@ENGINEERINGEXPRESS.COM
 ENGINEERINGEXPRESS.COM

CRAWFORD TRACEY CORPORATION
 3301 S.W. 13th DRIVE
 DEERFIELD BEACH, FL, 33442-8101
 Phn. (954) 698-6888
 PRO-TECH 455G ALUMINUM CURTAINWALL SYSTEM
 FLORIDA STATE APPROVAL

REMARKS	DATE	CHKD	DATE
FBC 2020 UPDATE	10/19/20	JEM	AJP

THIS DOCUMENT IS THE PROPERTY OF ENGINEERING EXPRESS, AND SHALL NOT BE REPRODUCED IN WHOLE OR PART WITHOUT WRITTEN CONSENT OF ENGINEERING EXPRESS. ALTERATIONS, ADDITIONS, OR OTHER MARKINGS TO THIS DOCUMENT ARE NOT PERMITTED AND INVALIDATE OUR CERTIFICATION.

COPYRIGHT ENGINEERING EXPRESS
 20-32267
 SCALE: NTS UNLESS NOTED
 13

GLASS TYPE E & G - LOADING CHART (S.M.I.)

72 (in.)		
SIDE A OR B (D.L.O.) (in.)		
SIDE A OR B (D.L.O.) (in.)	(+) P.S.F.	(-) P.S.F.
36	120	126
42	120	126
48	120	126
54	120	126
60	120	126
66	111	117
72	102	107
78	102	107
84	102	107
90	102	107
96	102	107
102	102	107
108	102	107
114	102	107
120	102	107
126	102	107
132	102	107
138	102	107
144	102	107
150	102	107
156	102	107
162	102	107
168	102	107
174	102	107

84 (in.)		
SIDE A OR B (D.L.O.) (in.)		
SIDE A OR B (D.L.O.) (in.)	(+) P.S.F.	(-) P.S.F.
36	120	126
42	120	126
48	120	126
54	120	126
60	120	126
66	111	117
72	102	107
78	94	99
84	87	92
90	87	92
96	87	92
102	87	92
108	87	92
114	87	92
120	87	92
126	87	92
132	87	92
138	87	92
144	87	92
150	87	92
156	87	92
162	87	92
168	87	92

96 (in.)		
SIDE A OR B (D.L.O.) (in.)		
SIDE A OR B (D.L.O.) (in.)	(+) P.S.F.	(-) P.S.F.
36	120	126
42	120	126
48	120	126
54	120	126
60	120	126
66	111	117
72	102	107
78	94	99
84	87	92
90	82	86
96	76	80
102	76	80
108	76	80
114	76	80
120	76	80
126	76	80
132	76	80
138	76	80
144	76	80
150	76	80

108.00 (in.)		
SIDE A OR B (D.L.O.) (in.)		
SIDE A OR B (D.L.O.) (in.)	(+) P.S.F.	(-) P.S.F.
36	120	126
42	120	126
48	120	126
54	120	126
60	120	126
66	111	117
72	102	107
78	94	99
84	87	92
90	82	86
96	76	80
102	72	75
108	68	71
114	68	71
120	68	71
126	68	71
132	68	71

120 (in.)		
SIDE A OR B (D.L.O.) (in.)		
SIDE A OR B (D.L.O.) (in.)	(+) P.S.F.	(-) P.S.F.
36	120	126
42	120	126
48	120	126
54	120	126
60	120	126
66	111	117
72	102	107
78	94	99
84	87	92
90	82	86
96	76	80
102	72	75
108	68	71
114	64	67
120	61	64

132 (in.)		
SIDE A OR B (D.L.O.) (in.)		
SIDE A OR B (D.L.O.) (in.)	(+) P.S.F.	(-) P.S.F.
36	120	126
42	120	126
48	120	126
54	120	126
60	120	126
66	111	117
72	102	107
78	94	99
84	87	92
90	82	86
96	76	80
102	72	75
108	68	71

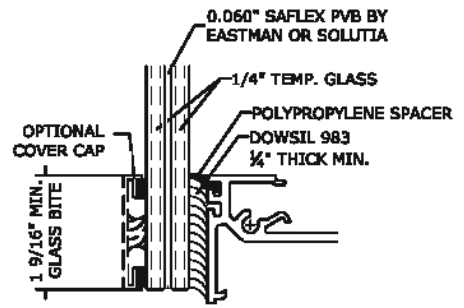

GLASS TYPE E
GLAZING DETAIL
 N.T.S.
GLASS RATING:
 SMALL MISSILE IMPACT
 3/8" GLASS

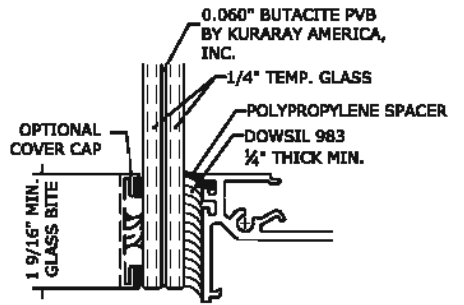

GLASS TYPE G
GLAZING DETAIL
 N.T.S.
GLASS RATING:
 SMALL MISSILE IMPACT
 3/8" GLASS

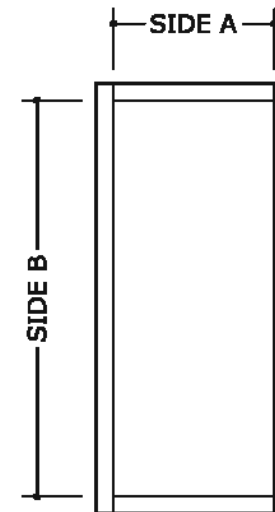

D.L.O. = DAYLIGHT OPENING

144 (in.)		
SIDE A OR B (D.L.O.) (in.)		
SIDE A OR B (D.L.O.) (in.)	(+) P.S.F.	(-) P.S.F.
36	120	126
42	120	126
48	120	126
54	120	126
60	120	126
66	111	117
72	102	107
78	94	99
84	87	92
90	82	86
96	76	80

156 (in.)		
SIDE A OR B (D.L.O.) (in.)		
SIDE A OR B (D.L.O.) (in.)	(+) P.S.F.	(-) P.S.F.
36	120	126
42	120	126
48	120	126
54	120	126
60	120	126
66	111	117
72	102	107
78	94	99
84	87	92
90	82	86

168.00 (in.)		
SIDE A OR B (D.L.O.) (in.)		
SIDE A OR B (D.L.O.) (in.)	(+) P.S.F.	(-) P.S.F.
36	120	126
42	120	126
48	120	126
54	120	126
60	120	126
66	111	117
72	102	107
78	94	99
84	87	92
90	82	86

180 (in.)		
SIDE A OR B (D.L.O.) (in.)		
SIDE A OR B (D.L.O.) (in.)	(+) P.S.F.	(-) P.S.F.
36	120	126
42	120	126
48	120	126
54	120	126
60	120	126
66	111	117
72	102	107
78	94	99

192 (in.)		
SIDE A OR B (D.L.O.) (in.)		
SIDE A OR B (D.L.O.) (in.)	(+) P.S.F.	(-) P.S.F.
36	120	126
42	120	126
48	120	126
54	120	126
60	120	126
66	111	117
72	102	107

204 (in.)		
SIDE A OR B (D.L.O.) (in.)		
SIDE A OR B (D.L.O.) (in.)	(+) P.S.F.	(-) P.S.F.
36	120	126
42	120	126
48	120	126
54	120	126
60	120	126
66	111	117
72	102	107

216 (in.)		
SIDE A OR B (D.L.O.) (in.)		
SIDE A OR B (D.L.O.) (in.)	(+) P.S.F.	(-) P.S.F.
36	120	126
42	120	126
48	120	126
54	120	126
60	120	126
66	111	117

228 (in.)		
SIDE A OR B (D.L.O.) (in.)		
SIDE A OR B (D.L.O.) (in.)	(+) P.S.F.	(-) P.S.F.
36	120	126
42	120	126
48	120	126
54	120	126
60	120	126

240 (in.)		
SIDE A OR B (D.L.O.) (in.)		
SIDE A OR B (D.L.O.) (in.)	(+) P.S.F.	(-) P.S.F.
36	120	126
42	120	126
48	120	126
54	120	126
60	120	126

FRANK BENNARDO, P.E.
 PE# 0046549 CA 9885



FL#29520.4

ENGINEERING EXPRESS
 CORPORATE OFFICE:
 160 SW 12th AVE, SUITE 106
 DEERFIELD BEACH, FL 33442
 (954) 354-0660 | (866) 396-9999
 TEAM@ENGINEERINGEXPRESS.COM
 ENGINEERINGEXPRESS.COM

CRAWFORD TRACEY CORPORATION
 3301 S.W. 13th DRIVE
 DEERFIELD BEACH, FL, 33442-8101
 Phn. (954) 698-6888
PRO-TECH 455G ALUMINUM CURTAINWALL SYSTEM
 FLORIDA STATE APPROVAL

REMARKS	DATE	CHKD	DATE
FBC 2020 UPDATE	10/19/20	JEM	AJP

THIS DOCUMENT IS THE PROPERTY OF ENGINEERING EXPRESS, AND SHALL NOT BE REPRODUCED IN WHOLE OR PART WITHOUT WRITTEN CONSENT OF ENGINEERING EXPRESS. ALTERATIONS, ADDITIONS, OR OTHER MARKINGS TO THIS DOCUMENT ARE NOT PERMITTED AND INVALIDATE OUR CERTIFICATION.

COPYRIGHT ENGINEERING EXPRESS

20-32267

SCALE: NTS UNLESS NOTED

14

GLASS TYPE H, I, J - LOADING CHART (S.M.I.)

60 (In.)		
SIDE A OR B (D.L.O.) (In.)		
SIDE A OR B (D.L.O.) (In.)	(+) P.S.F.	(-) P.S.F.
36	100	100
42	100	100
48	93	93
54	83	83
60	75	75
66	75	75
72	75	75
78	75	75
84	75	75

72 (In.)		
SIDE A OR B (D.L.O.) (In.)		
SIDE A OR B (D.L.O.) (In.)	(+) P.S.F.	(-) P.S.F.
36	100	100
42	100	100
48	93	93
54	83	83
60	75	75
66	68	68
72	62	62

84 (In.)		
SIDE A OR B (D.L.O.) (In.)		
SIDE A OR B (D.L.O.) (In.)	(+) P.S.F.	(-) P.S.F.
36	100	100
42	100	100
48	93	93
54	83	83
60	75	75

96 (In.)		
SIDE A OR B (D.L.O.) (In.)		
SIDE A OR B (D.L.O.) (In.)	(+) P.S.F.	(-) P.S.F.
36	100	100
42	100	100
48	93	93
54	83	83

108.00 (In.)		
SIDE A OR B (D.L.O.) (In.)		
SIDE A OR B (D.L.O.) (In.)	(+) P.S.F.	(-) P.S.F.
36	100	100
42	100	100
48	93	93

120 (In.)		
SIDE A OR B (D.L.O.) (In.)		
SIDE A OR B (D.L.O.) (In.)	(+) P.S.F.	(-) P.S.F.
36	100	100
42	100	100

132 (In.)		
SIDE A OR B (D.L.O.) (In.)		
WIDTH (In.)	(+) P.S.F.	(-) P.S.F.
36	100	100

144 (In.)		
SIDE A OR B (D.L.O.) (In.)		
WIDTH (In.)	(+) P.S.F.	(-) P.S.F.
36	100	100

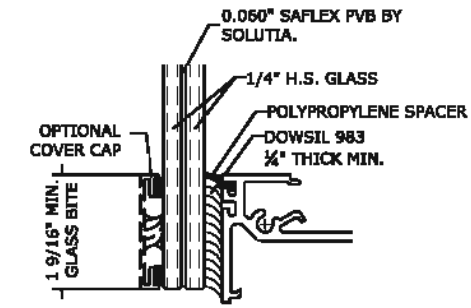

GLASS TYPE 
GLAZING DETAIL
 N.T.S.
GLASS RATING:
 SMALL MISSILE IMPACT
 $\frac{3}{16}$ " GLASS

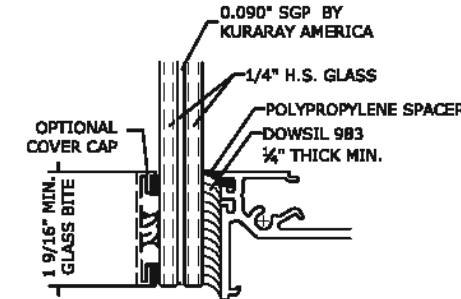

GLASS TYPE 
GLAZING DETAIL
 N.T.S.
GLASS RATING:
 SMALL MISSILE IMPACT
 $\frac{3}{16}$ " GLASS

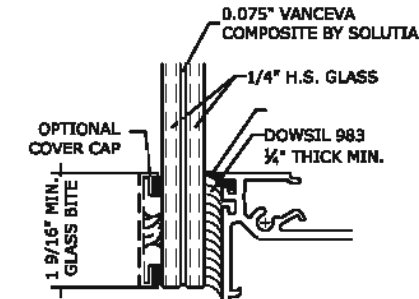

GLASS TYPE 
GLAZING DETAIL
 N.T.S.
GLASS RATING:
 SMALL MISSILE IMPACT
 $\frac{3}{16}$ " GLASS

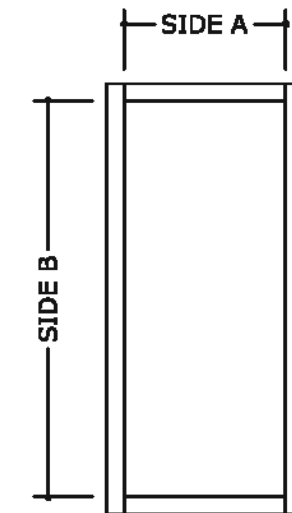

D.L.O. = DAYLIGHT OPENING

FRANK BENNARDO, P.E.
 PE# 0046549 CA 9885



FL#29520.4

ENGINEERING EXPRESS
 CORPORATE OFFICE:
 160 SW 12th AVE, SUITE 106
 DEERFIELD BEACH, FL 33442
 (954) 354-0660 | (866) 996-9999
 TEAM@ENGINEERINGEXPRESS.COM
 ENGINEERINGEXPRESS.COM

CRAWFORD TRACEY CORPORATION
 3301 S.W. 13th DRIVE
 DEERFIELD BEACH, FL, 33442-8101
 Phn. (954) 698-6888
PRO-TECH 455G ALUMINUM CURTAINWALL SYSTEM
 FLORIDA STATE APPROVAL

REMARKS	DATE	CHKD	DATE
FBC 2020 UPDATE	10/19/20	JEM	AJP

THIS DOCUMENT IS THE PROPERTY OF ENGINEERING EXPRESS, AND SHALL NOT BE REPRODUCED IN WHOLE OR PART, WITHOUT WRITTEN CONSENT OF ENGINEERING EXPRESS. ALTERATIONS, ADDITIONS, OR OTHER MARKINGS TO THIS DOCUMENT ARE NOT PERMITTED AND INVALIDATE OUR CERTIFICATION.

COPYRIGHT ENGINEERING EXPRESS®

20-32267

SCALE: NTS UNLESS NOTED

15

GLASS TYPE M - LOADING CHART (S.M.I.)

60 (in.)		
SIDE A OR B (D.L.O.) (in.)		
SIDE A OR B (D.L.O.) (in.)	(+) P.S.F.	(-) P.S.F.
24	100	100
30	100	100
36	100	100
42	100	100
48	100	100
54	100	100
60	95	95
66	95	95
72	95	95
78	95	95
84	95	95

72 (in.)		
SIDE A OR B (D.L.O.) (in.)		
SIDE A OR B (D.L.O.) (in.)	(+) P.S.F.	(-) P.S.F.
24	100	100
30	100	100
36	100	100
42	100	100
48	100	100
54	100	100
60	95	95
66	86	86
72	79	79

84 (in.)		
SIDE A OR B (D.L.O.) (in.)		
SIDE A OR B (D.L.O.) (in.)	(+) P.S.F.	(-) P.S.F.
24	100	100
30	100	100
36	100	100
42	100	100
48	100	100
54	100	100
60	95	95

96 (in.)		
SIDE A OR B (D.L.O.) (in.)		
SIDE A OR B (D.L.O.) (in.)	(+) P.S.F.	(-) P.S.F.
24	100	100
30	100	100
36	100	100
42	100	100
48	100	100
54	100	100

108.00 (in.)		
SIDE A OR B (D.L.O.) (in.)		
SIDE A OR B (D.L.O.) (in.)	(+) P.S.F.	(-) P.S.F.
24	100	100
30	100	100
36	100	100
42	100	100
48	100	100

120 (in.)		
SIDE A OR B (D.L.O.) (in.)		
SIDE A OR B (D.L.O.) (in.)	(+) P.S.F.	(-) P.S.F.
24	100	100
30	100	100
36	100	100
42	100	100

132 (in.)		
SIDE A OR B (D.L.O.) (in.)		
WIDTH (in.)	(+) P.S.F.	(-) P.S.F.
24	100	100
30	100	100

144 (in.)		
SIDE A OR B (D.L.O.) (in.)		
WIDTH (in.)	(+) P.S.F.	(-) P.S.F.
24	100	100
30	100	100

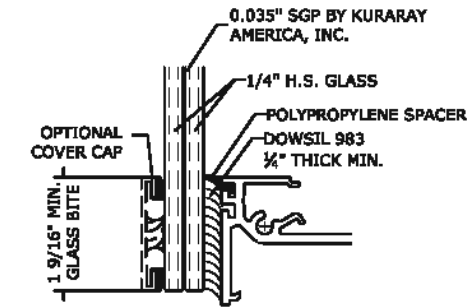

GLASS TYPE **M**
GLAZING DETAIL
 N.T.S.
GLASS RATING:
 SMALL MISSILE IMPACT
 1 1/8" GLASS

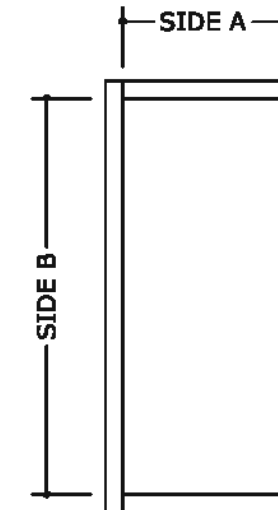

D.L.O. = DAYLIGHT OPENING

FRANK BENNARDO, P.E.
 PE# 0046549 CA 9885



FL#29520.4

ENGINEERING EXPRESS
 CORPORATE OFFICE:
 160 SW 12th AVE, SUITE 106
 DEERFIELD BEACH, FL 33442
 (954) 354-0660 | (866) 396-9999
 TEAM@ENGINEERINGEXPRESS.COM
 ENGINEERINGEXPRESS.COM

CRAWFORD TRACEY CORPORATION

3301 S.W. 13th DRIVE
 DEERFIELD BEACH, FL, 33442-8101
 Phn. (954) 698-6888

PRO-TECH 455G ALUMINUM CURTAINWALL SYSTEM
 FLORIDA STATE APPROVAL

REMARKS	DATE	CHKD	DATE
FBC 2020 UPDATE	10/19/20	JEM	AJP

THIS DOCUMENT IS THE PROPERTY OF ENGINEERING EXPRESS, AND SHALL NOT BE REPRODUCED IN WHOLE OR PART, WITHOUT WRITTEN CONSENT OF ENGINEERING EXPRESS. ALTERATIONS, ADDITIONS, OR OTHER MARKINGS TO THIS DOCUMENT ARE NOT PERMITTED AND INVALIDATE OUR CERTIFICATION.

COPYRIGHT ENGINEERING EXPRESS

20-32267

SCALE: NTS UNLESS NOTED

16



GLASS TYPE A1 - LOADING CHART (S.M.I.)

72 (in.)		
SIDE A OR B (D.L.O.) (in.)		
SIDE A OR B (D.L.O.) (in.)	(+) P.S.F.	(-) P.S.F.
36	100	100
42	100	100
48	100	100
54	100	100
60	95	95
66	88	88
72	79	79

84 (in.)		
SIDE A OR B (D.L.O.) (in.)		
SIDE A OR B (D.L.O.) (in.)	(+) P.S.F.	(-) P.S.F.
36	100	100
42	100	100
48	100	100
54	100	100
60	95	95

96 (in.)		
SIDE A OR B (D.L.O.) (in.)		
SIDE A OR B (D.L.O.) (in.)	(+) P.S.F.	(-) P.S.F.
36	100	100
42	100	100
48	100	100
54	100	100

108.00 (in.)		
SIDE A OR B (D.L.O.) (in.)		
SIDE A OR B (D.L.O.) (in.)	(+) P.S.F.	(-) P.S.F.
36	100	100
42	100	100
48	100	100

120 (in.)		
SIDE A OR B (D.L.O.) (in.)		
SIDE A OR B (D.L.O.) (in.)	(+) P.S.F.	(-) P.S.F.
36	100	100
42	100	100

132 (in.)		
SIDE A OR B (D.L.O.) (in.)		
SIDE A OR B (D.L.O.) (in.)	(+) P.S.F.	(-) P.S.F.
36	100	100

144 (in.)		
SIDE A OR B (D.L.O.) (in.)		
SIDE A OR B (D.L.O.) (in.)	(+) P.S.F.	(-) P.S.F.
36	100	100

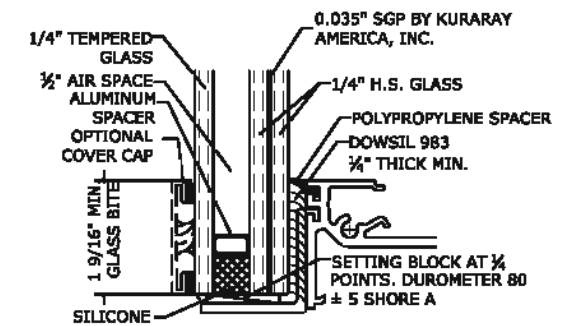

GLASS TYPE **A1**
GLAZING DETAIL
 N.T.S.
GLASS RATING:
 SMALL MISSILE IMPACT
 1 3/8" GLASS

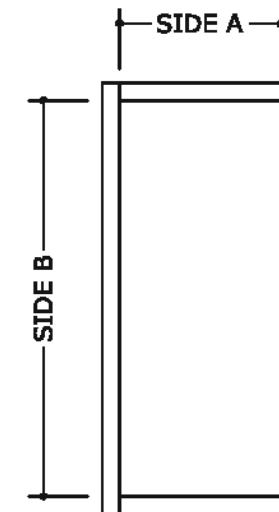

D.L.O. = DAYLIGHT OPENING

FRANK BENNARDO, P.E.
 PE# 0046549 CA 9885



FL#29520.4

ENGINEERING EXPRESS
 CORPORATE OFFICE:
 160 SW 12th AVE, SUITE 106
 DEERFIELD BEACH, FL 33442
 (954) 354-0660 | (866) 396-9999
 TEAM@ENGINEERINGEXPRESS.COM
 ENGINEERINGEXPRESS.COM

CRAWFORD TRACEY CORPORATION

3301 S.W. 13th DRIVE
 DEERFIELD BEACH, FL, 33442-8101
 Phn. (954) 698-6888

PRO-TECH 455G ALUMINUM CURTAINWALL SYSTEM
 FLORIDA STATE APPROVAL

REMARKS	DRWN	CHKD	DATE
FBC 2020 UPDATE	JEM	AJP	10/19/20

THIS DOCUMENT IS THE PROPERTY OF ENGINEERING EXPRESS, AND SHALL NOT BE REPRODUCED IN WHOLE OR PART, WITHOUT WRITTEN CONSENT OF ENGINEERING EXPRESS. ALTERATIONS, ADDITIONS, OR OTHER MARKINGS TO THIS DOCUMENT ARE NOT PERMITTED AND INVALIDATE OUR CERTIFICATION.

COPYRIGHT ENGINEERING EXPRESS

20-32267

SCALE: NTS UNLESS NOTED

17



SINGLE SPAN MULLION LOADING TABLES (P.S.F.)

WIDTH (in.)	HEIGHT 60 (in.)					
	(M1) NON-REINFORCED		M2 (LIGHT REINFORCEMENT)		M3 (HEAVY REINFORCEMENT)	
	(+) P.S.F.	(-) P.S.F.	(+) P.S.F.	(-) P.S.F.	(+) P.S.F.	(-) P.S.F.
36	80	80	80	80	100	100
42	80	80	80	80	100	100
48	80	80	80	80	100	100
54	80	80	80	80	100	100
60	80	80	80	80	100	100
62	80	80	80	80	100	100
66	80	80	80	80	100	100
69	80	80	80	80	100	100
72	80	80	80	80	100	100
78	80	80	80	80	100	100

WIDTH (in.)	HEIGHT 72 (in.)					
	(M1) NON-REINFORCED		M2 (LIGHT REINFORCEMENT)		M3 (HEAVY REINFORCEMENT)	
	(+) P.S.F.	(-) P.S.F.	(+) P.S.F.	(-) P.S.F.	(+) P.S.F.	(-) P.S.F.
36	80	80	80	80	100	100
42	80	80	80	80	100	100
48	80	80	80	80	100	100
54	80	80	80	80	100	100
60	80	80	80	80	100	100
62	80	80	80	80	100	100
66	80	80	80	80	100	100
69	80	80	80	80	100	100
72	80	80	80	80	100	100
78	80	80	80	80	100	100

WIDTH (in.)	HEIGHT 84 (in.)					
	(M1) NON-REINFORCED		M2 (LIGHT REINFORCEMENT)		M3 (HEAVY REINFORCEMENT)	
	(+) P.S.F.	(-) P.S.F.	(+) P.S.F.	(-) P.S.F.	(+) P.S.F.	(-) P.S.F.
36	80	80	80	80	100	100
42	80	80	80	80	100	100
48	80	80	80	80	100	100
54	80	80	80	80	100	100
60	80	80	80	80	100	100
62	80	80	80	80	100	100
66	80	80	80	80	100	100
69	80	80	80	80	100	100
72	-	-	-	-	-	-
78	-	-	-	-	-	-

WIDTH (in.)	HEIGHT 96 (in.)					
	(M1) NON-REINFORCED		M2 (LIGHT REINFORCEMENT)		M3 (HEAVY REINFORCEMENT)	
	(+) P.S.F.	(-) P.S.F.	(+) P.S.F.	(-) P.S.F.	(+) P.S.F.	(-) P.S.F.
36	80	80	80	80	100	100
42	80	80	80	80	100	100
48	80	80	80	80	100	100
54	80	80	80	80	100	100
60	80	80	80	80	100	100
62	80	80	80	80	100	100
66	80	80	80	80	100	100
69	-	-	-	-	-	-
72	-	-	-	-	-	-
78	-	-	-	-	-	-

WIDTH (in.)	HEIGHT 108 (in.)					
	(M1) NON-REINFORCED		M2 (LIGHT REINFORCEMENT)		M3 (HEAVY REINFORCEMENT)	
	(+) P.S.F.	(-) P.S.F.	(+) P.S.F.	(-) P.S.F.	(+) P.S.F.	(-) P.S.F.
36	58	58	80	80	100	100
42	51	51	80	80	100	100
48	45	45	73	73	100	100
54	-	-	-	-	-	-
60	-	-	-	-	-	-
62	-	-	-	-	-	-
66	-	-	-	-	-	-
69	-	-	-	-	-	-
72	-	-	-	-	-	-
78	-	-	-	-	-	-

WIDTH (in.)	HEIGHT 120 (in.)					
	(M1) NON-REINFORCED		M2 (LIGHT REINFORCEMENT)		M3 (HEAVY REINFORCEMENT)	
	(+) P.S.F.	(-) P.S.F.	(+) P.S.F.	(-) P.S.F.	(+) P.S.F.	(-) P.S.F.
36	42	42	69	69	95	95
42	37	37	60	60	82	82
48	32	32	53	53	73	73
54	-	-	-	-	-	-
60	-	-	-	-	-	-
62	-	-	-	-	-	-
66	-	-	-	-	-	-
69	-	-	-	-	-	-
72	-	-	-	-	-	-
78	-	-	-	-	-	-

WIDTH (in.)	HEIGHT 132 (in.)					
	(M1) NON-REINFORCED		M2 (LIGHT REINFORCEMENT)		M3 (HEAVY REINFORCEMENT)	
	(+) P.S.F.	(-) P.S.F.	(+) P.S.F.	(-) P.S.F.	(+) P.S.F.	(-) P.S.F.
36	-	-	-	-	77	77
42	-	-	-	-	67	67
48	-	-	-	-	-	-
54	-	-	-	-	-	-
60	-	-	-	-	-	-
62	-	-	-	-	-	-
66	-	-	-	-	-	-
69	-	-	-	-	-	-
72	-	-	-	-	-	-
78	-	-	-	-	-	-

WIDTH (in.)	HEIGHT 144 (in.)					
	(M1) NON-REINFORCED		M2 (LIGHT REINFORCEMENT)		M3 (HEAVY REINFORCEMENT)	
	(+) P.S.F.	(-) P.S.F.	(+) P.S.F.	(-) P.S.F.	(+) P.S.F.	(-) P.S.F.
36	-	-	-	-	70	70
42	-	-	-	-	59	59
48	-	-	-	-	-	-
54	-	-	-	-	-	-
60	-	-	-	-	-	-
62	-	-	-	-	-	-
66	-	-	-	-	-	-
69	-	-	-	-	-	-
72	-	-	-	-	-	-
78	-	-	-	-	-	-

WIDTH (in.)	HEIGHT 156 (in.)					
	(M1) NON-REINFORCED		M2 (LIGHT REINFORCEMENT)		M3 (HEAVY REINFORCEMENT)	
	(+) P.S.F.	(-) P.S.F.	(+) P.S.F.	(-) P.S.F.	(+) P.S.F.	(-) P.S.F.
36	-	-	-	-	55	55
42	-	-	-	-	46	46
48	-	-	-	-	-	-
54	-	-	-	-	-	-
60	-	-	-	-	-	-
62	-	-	-	-	-	-
66	-	-	-	-	-	-
69	-	-	-	-	-	-
72	-	-	-	-	-	-
78	-	-	-	-	-	-

M1 NON REINFORCED MULLION

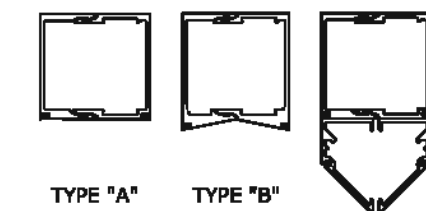

	Ix (in.^4)	Sx (in.^3)
MULLION	3.568	2.433
ALT. MULL.	4.084	2.689
ALUM. REINF.	-	-
STEEL REINF.	-	-

M2 LIGHT REINFORCED MULLION

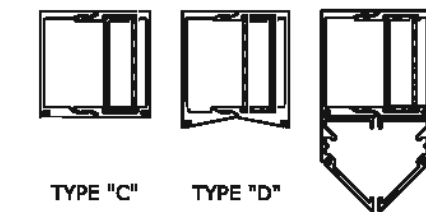

	Ix (in.^4)	Sx (in.^3)
MULLION	3.568	2.433
ALT. MULL.	4.084	2.689
STEEL TUBE	0.147	0.594
TOTAL Sx	-	2.973

M3 HEAVY REINFORCED MULLION

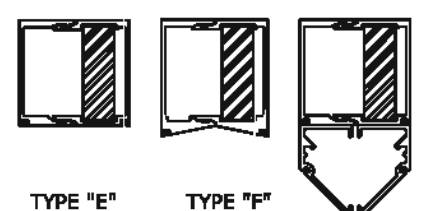

	Ix (in.^4)	Sx (in.^3)
MULLION	3.568	2.433
ALT. MULL.	4.084	2.689
STEEL BAR	0.250	1.500
TOTAL Sx	-	3.771

TOTAL Ix =
Ix ALUM + Ix STEEL x 2.9

FRANK BENNARDO, P.E.
PE# 0046549 CA 9885



FL#29520.4

ENGINEERING EXPRESS
 CORPORATE OFFICE:
 160 SW 12th AVE, SUITE 106
 DEERFIELD BEACH, FL 33442
 (954) 354-0660 | (866) 396-9999
 TEAM@ENGINEERINGEXPRESS.COM
 ENGINEERINGEXPRESS.COM

CRAWFORD TRACEY CORPORATION
 3301 S.W. 13th DRIVE
 DEERFIELD BEACH, FL, 33442-8101
 Phn. (954) 698-6888
 PRO-TECH 455G ALUMINUM CURTAINWALL SYSTEM
 FLORIDA STATE APPROVAL

REMARKS	DATE	DRWN	CHKD
FBC 2020 UPDATE	10/19/20	JEM	AJP

THIS DOCUMENT IS THE PROPERTY OF ENGINEERING EXPRESS, AND SHALL NOT BE REPRODUCED IN WHOLE OR PART WITHOUT WRITTEN CONSENT OF ENGINEERING EXPRESS. ALTERATIONS, ADDITIONS, OR OTHER MARKINGS TO THIS DOCUMENT ARE NOT PERMITTED AND INVALIDATE OUR CERTIFICATION.

COPYRIGHT ENGINEERING EXPRESS®
20-32267
 SCALE: NTS UNLESS NOTED

18

MULLION CAPACITIES ARE EQUAL WITH OR WITHOUT HORIZONTALS.

LINEAR INTERPOLATION BETWEEN WIDTHS OR HEIGHTS ALLOWED.

MULLION TRIBUTARY WIDTH

$$W = \frac{W_1 + W_2}{2}$$

SIDE LOADED SYSTEM

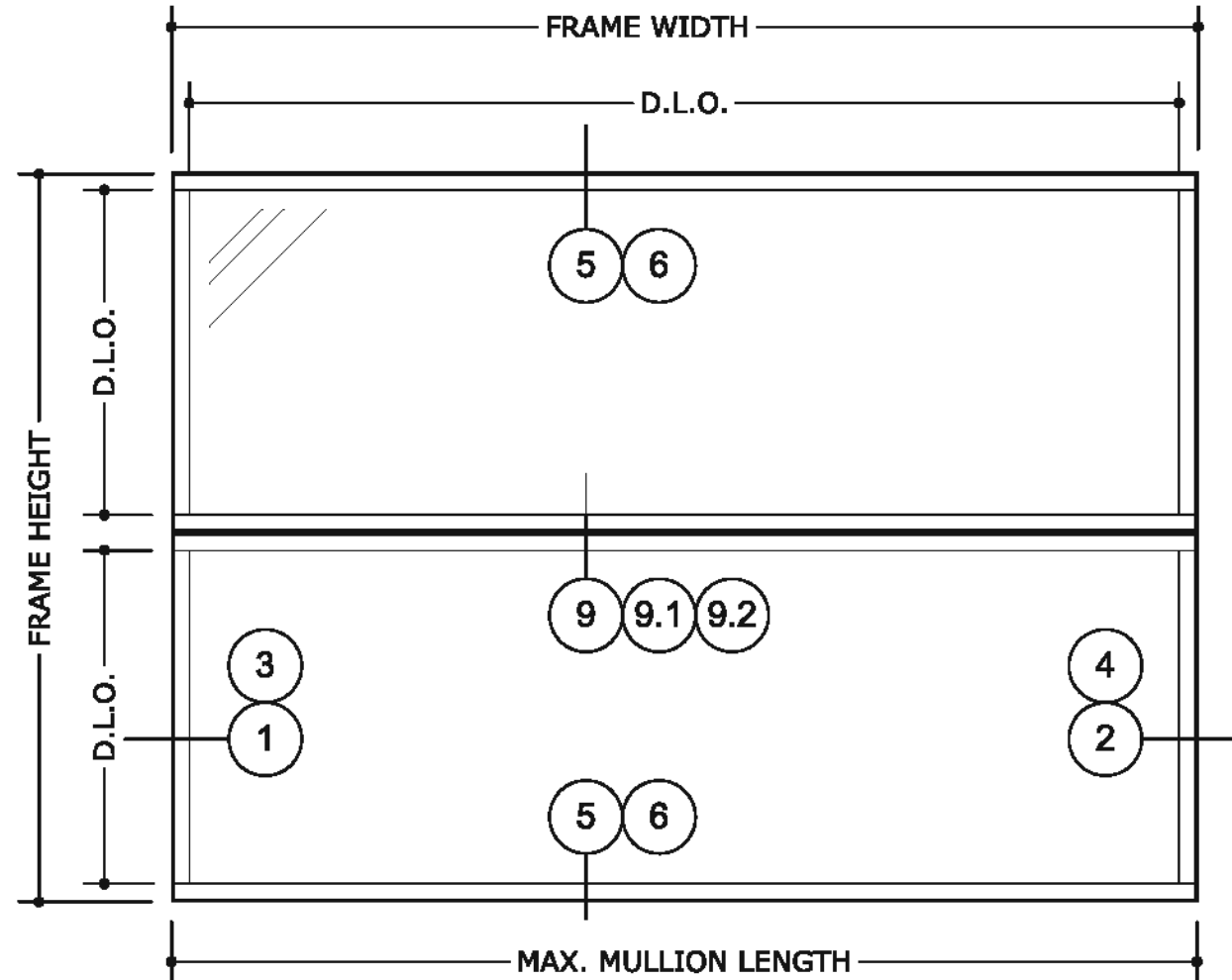

TYPICAL SIDE LOADED FRAME

SIDE LOADED SYSTEMS MAY BE USED GIVEN THE SYSTEM IS DESIGNED AND APPROVED BY A PROFESSIONAL ENGINEER BASED ON SITE SPECIFIC CONDITIONS.

MULLION CAPACITIES ARE EQUAL WITH OR WITHOUT HORIZONTALS.

MULLION TRIBUTARY WIDTH

$$W = \frac{W1}{2} + \frac{W2}{2}$$

SIDE-LOADED MULLION

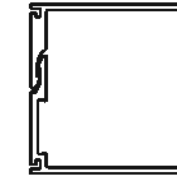

TYPE "A"

	Ix (in.^4)	Sx (in.^3)
MULLION	3.568	2.433
STEEL TUBE	-	-
STEEL BAR	-	-

SIDE-LOADED MULLION

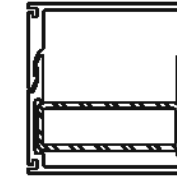

TYPE "C"

	Ix (in.^4)	Sx (in.^3)
MULLION	3.568	2.433
STEEL TUBE	0.147	0.594
STEEL BAR	-	-

SIDE-LOADED MULLION

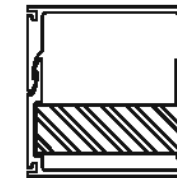

TYPE "E"

	Ix (in.^4)	Sx (in.^3)
MULLION	3.568	2.433
STEEL TUBE	-	-
STEEL BAR	0.250	1.500



FL#29520.4

ENGINEERING EXPRESS
 CORPORATE OFFICE:
 160 SW 12th AVE, SUITE 106
 DEERFIELD BEACH, FL 33442
 (954) 354-0660 | (866) 396-9999
 TEAM@ENGINEERINGEXPRESS.COM
 ENGINEERINGEXPRESS.COM

CRAWFORD TRACEY CORPORATION
 3301 S.W. 13th DRIVE
 DEERFIELD BEACH, FL, 33442-8101
 Phn. (954) 698-6888
 PRO-TECH 455G ALUMINUM CURTAINWALL SYSTEM
 FLORIDA STATE APPROVAL

REMARKS	DATE	DRWN	CHKD
FBC 2020 UPDATE	10/19/20	JEM	AJP

THIS DOCUMENT IS THE PROPERTY OF ENGINEERING EXPRESS, AND SHALL NOT BE REPRODUCED IN WHOLE OR PART WITHOUT WRITTEN CONSENT OF ENGINEERING EXPRESS. ALTERATIONS, ADDITIONS, OR OTHER MARKINGS TO THIS DOCUMENT ARE NOT PERMITTED AND INVALIDATE OUR CERTIFICATION.

COPYRIGHT ENGINEERING EXPRESS®

20-32267

SCALE: NTS UNLESS NOTED



FL#29520.4

ENGINEERING EXPRESS
CORPORATE OFFICE:
160 SW 12th AVE, SUITE 106
DEERFIELD BEACH, FL 33442
(954) 354-0660 | (866) 396-9999
TEAM@ENGINEERINGEXPRESS.COM
ENGINEERINGEXPRESS.COM

CRAWFORD TRACEY CORPORATION
3301 S.W. 13th DRIVE
DEERFIELD BEACH, FL, 33442-8101
Phn. (954) 698-6888

PRO-TECH 455G ALUMINUM CURTAINWALL SYSTEM
FLORIDA STATE APPROVAL

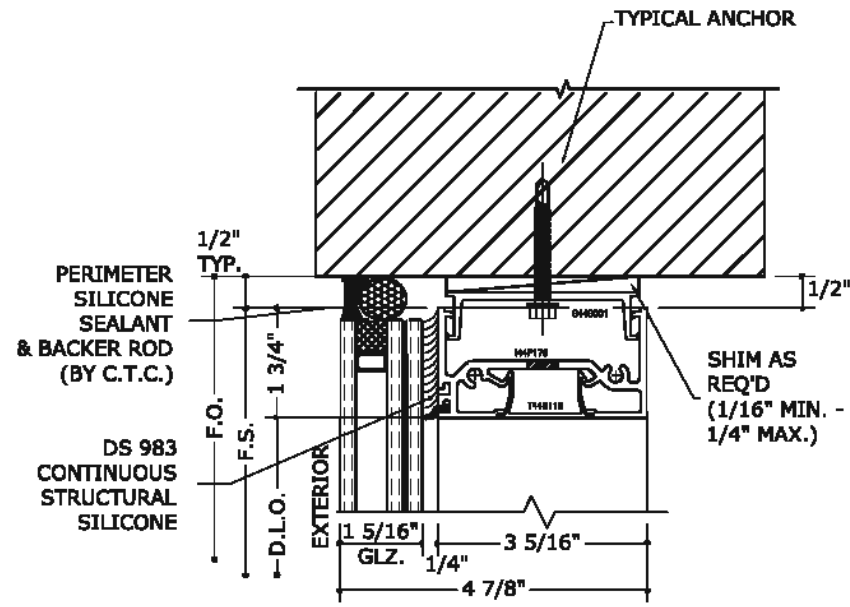

1 HEAD DETAIL

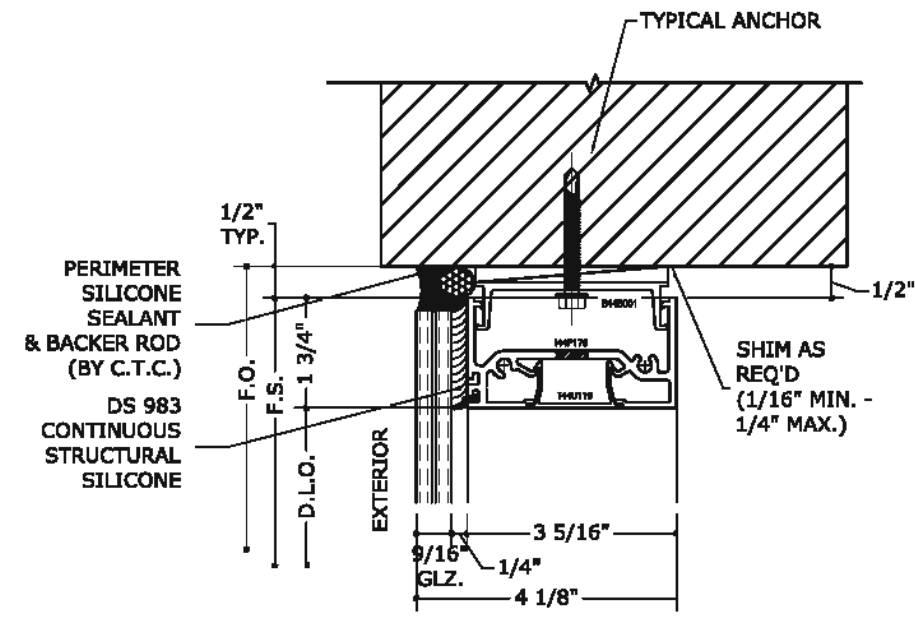

3 HEAD DETAIL

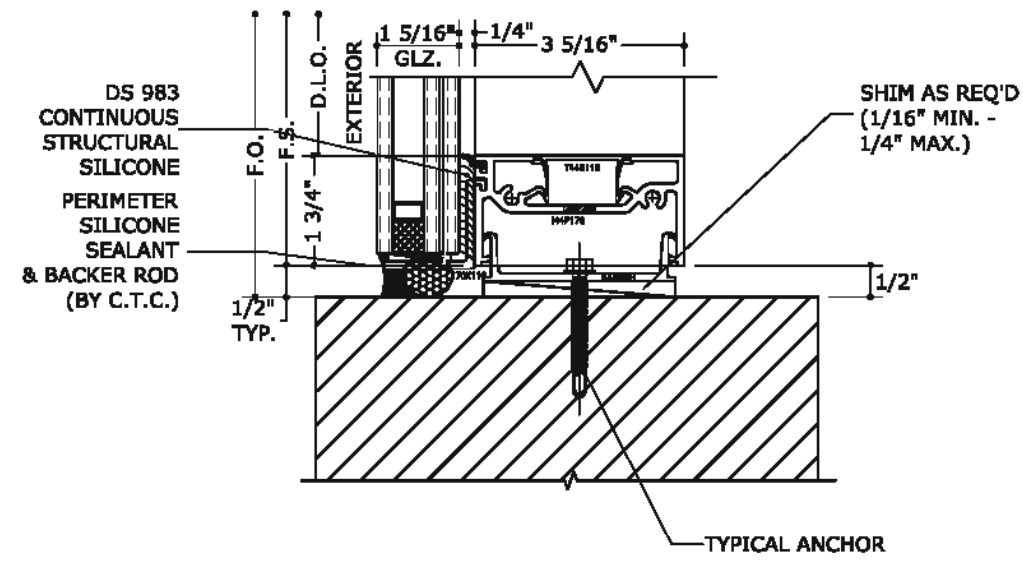

2 SILL DETAIL

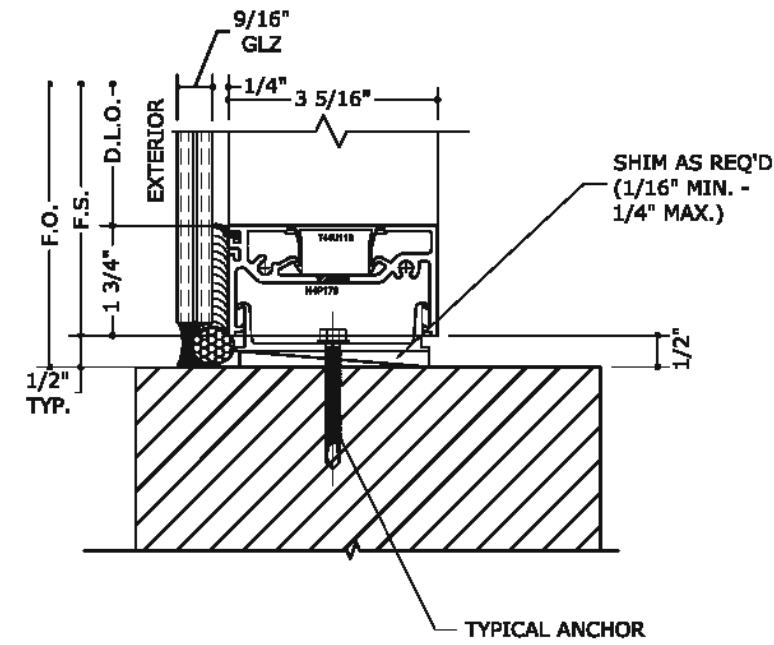

4 SILL DETAIL

NOTE:
WOOD BUCKS AND METAL STRUCTURES NOT BY CRAWFORD TRACEY MUST SUPPORT LOADS IMPOSED BY GLAZING SYSTEM AND TRANSFER THEM TO THE BUILDING STRUCTURE.

NOTE:
• SHIM SIZES GREATER THAT THE ONE SHOWN IN THE DETAILS ARE PERMITTED UNDER SITE SPECIFIC CONDITIONS.
• MODIFICATIONS TO THE ANCHORING WILL BE REQUIRED FOR THESE CONDITIONS AND SHALL BE DONE BY A PROFESSIONAL ENGINEER.

REMARKS	DATE	CHKD	DATE
FBC 2020 UPDATE	10/19/20	JEM	AJP

THIS DOCUMENT IS THE PROPERTY OF ENGINEERING EXPRESS, AND SHALL NOT BE REPRODUCED IN WHOLE OR PART WITHOUT WRITTEN CONSENT OF ENGINEERING EXPRESS. ALTERATIONS, ADDITIONS, OR OTHER MARKINGS TO THIS DOCUMENT ARE NOT PERMITTED AND INVALIDATE OUR CERTIFICATION.

COPYRIGHT ENGINEERING EXPRESS

20-32267

SCALE: NTS UNLESS NOTED



FL#29520.4

ENGINEERING EXPRESS
CORPORATE OFFICE:
160 SW 12th AVE, SUITE 106
DEERFIELD BEACH, FL 33442
(954) 354-0660 | (866) 396-9999
TEAM@ENGINEERINGEXPRESS.COM
ENGINEERINGEXPRESS.COM

CRAWFORD TRACEY CORPORATION
3301 S.W. 13th DRIVE
DEERFIELD BEACH, FL, 33442-8101
Phn. (954) 698-6888
PRO-TECH 455G ALUMINUM CURTAINWALL SYSTEM
FLORIDA STATE APPROVAL

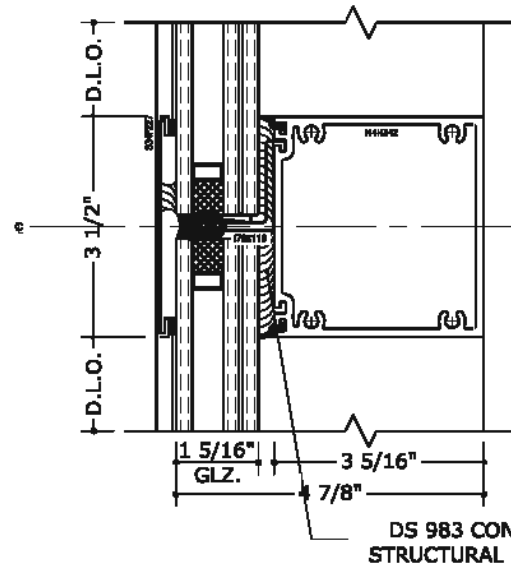

7 HORIZONTAL INTERMEDIATE DETAIL

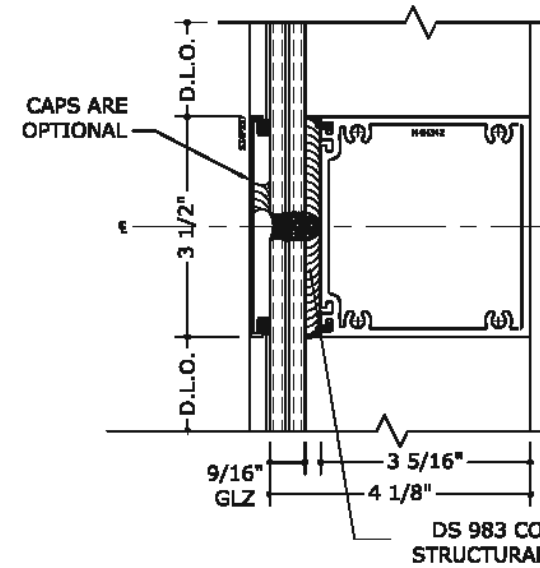

8 HORIZONTAL INTERMEDIATE DETAIL

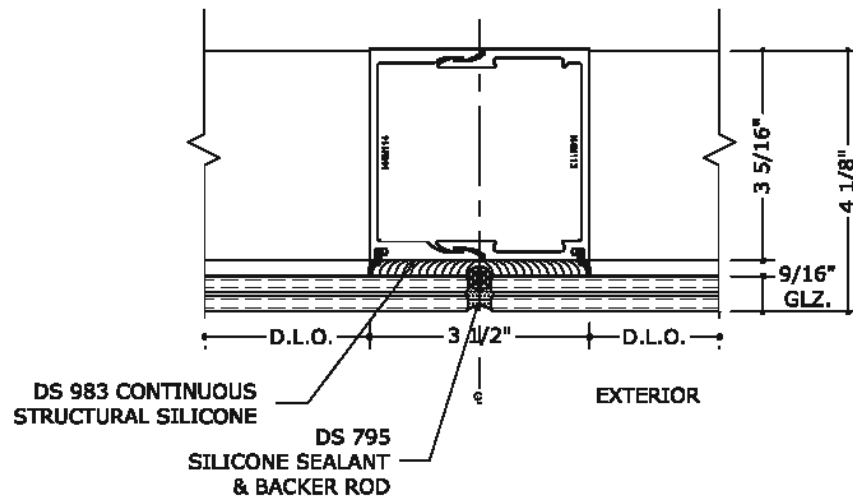

9 VERTICAL INTERMEDIATE DETAIL
REINFORCEMENT TO BE INCLUDED AS NEEDED
BASED UPON SITE SPECIFIC PRESSURES

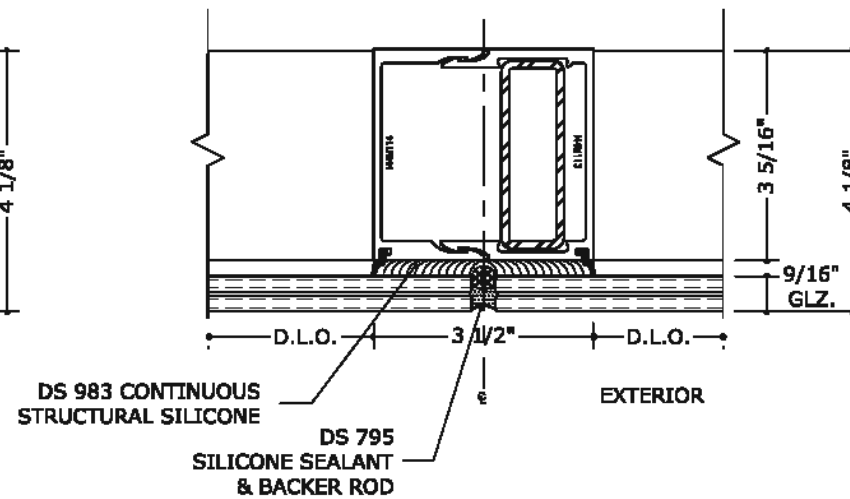

9.1 VERTICAL INTERMEDIATE DETAIL
REINFORCEMENT TO BE INCLUDED AS NEEDED
BASED UPON SITE SPECIFIC PRESSURES

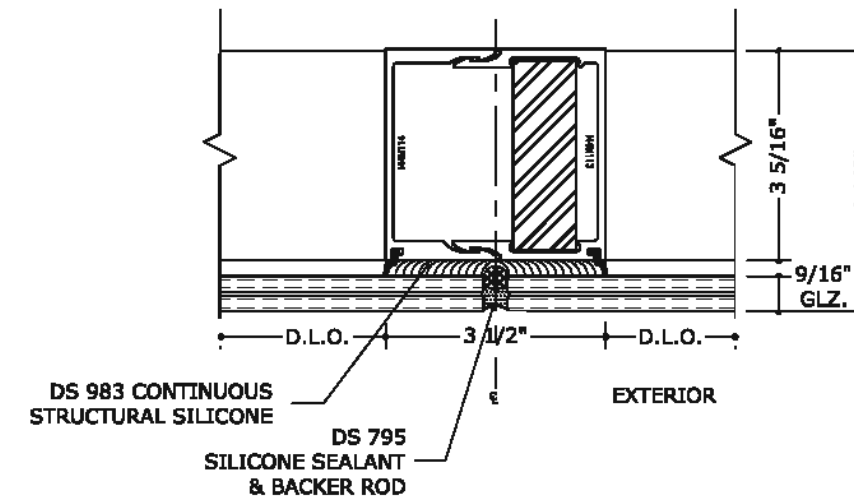

9.2 VERTICAL INTERMEDIATE DETAIL
REINFORCEMENT TO BE INCLUDED AS NEEDED
BASED UPON SITE SPECIFIC PRESSURES

REMARKS	DATE	CHKD	DATE
FBC 2020 UPDATE	10/19/20	JEM	AJP

THIS DOCUMENT IS THE PROPERTY OF ENGINEERING EXPRESS, AND SHALL NOT BE REPRODUCED IN WHOLE OR PART WITHOUT WRITTEN CONSENT OF ENGINEERING EXPRESS. ALTERATIONS, ADDITIONS, OR OTHER MARKINGS TO THIS DOCUMENT ARE NOT PERMITTED AND INVALIDATE OUR CERTIFICATION.

COPYRIGHT ENGINEERING EXPRESS®

20-32267

SCALE: NTS UNLESS NOTED

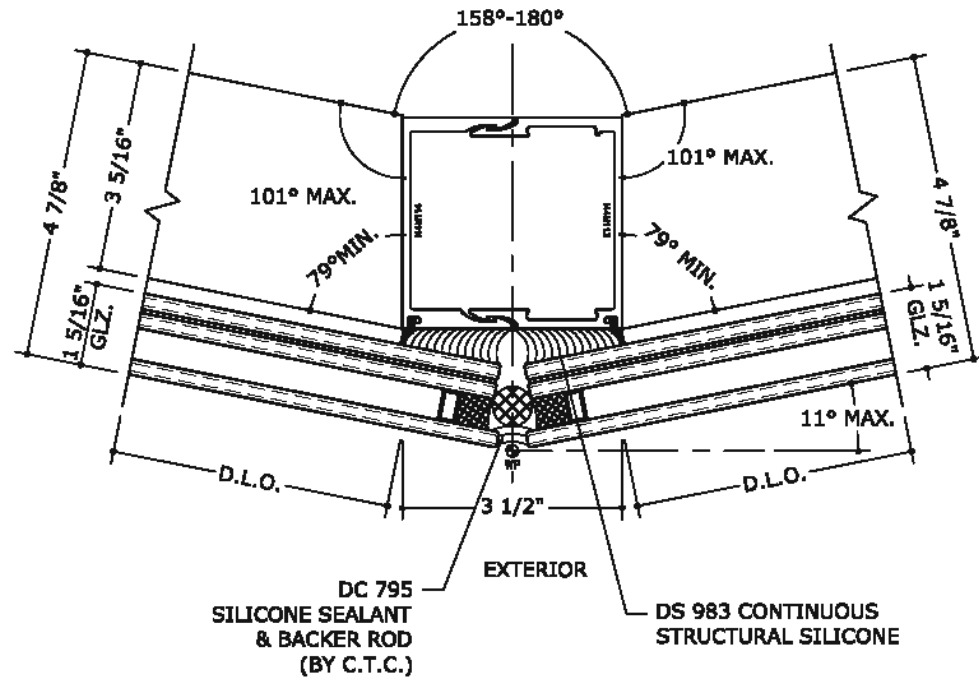

10 VERTICAL INTERMEDIATE DETAIL
 REINFORCEMENT TO BE INCLUDED AS NEEDED
 BASED UPON SITE SPECIFIC PRESSURES

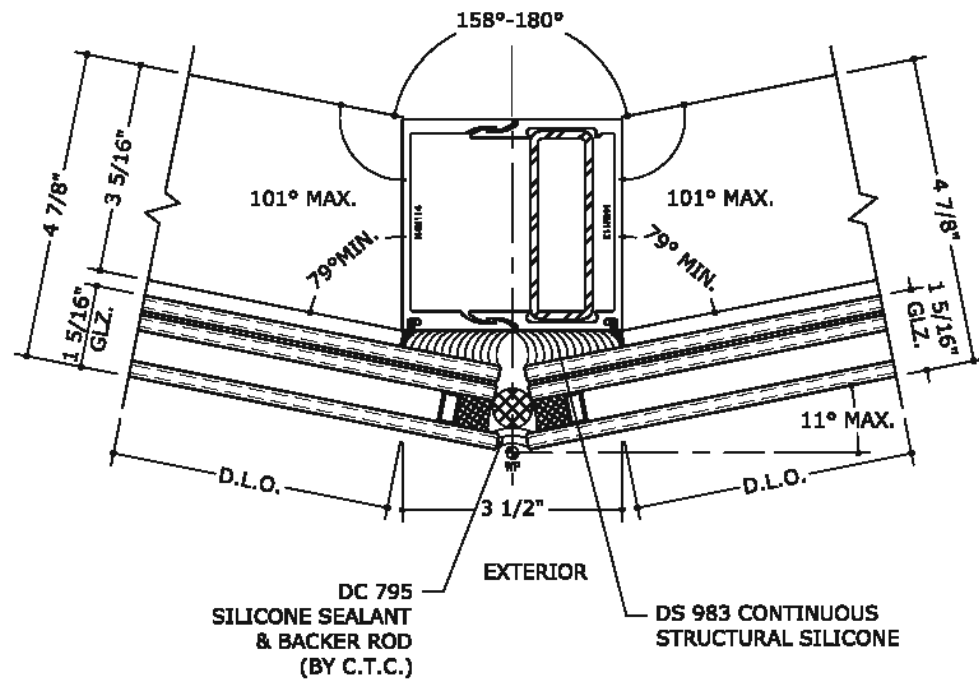

10.1 VERTICAL INTERMEDIATE DETAIL
 REINFORCEMENT TO BE INCLUDED AS NEEDED
 BASED UPON SITE SPECIFIC PRESSURES

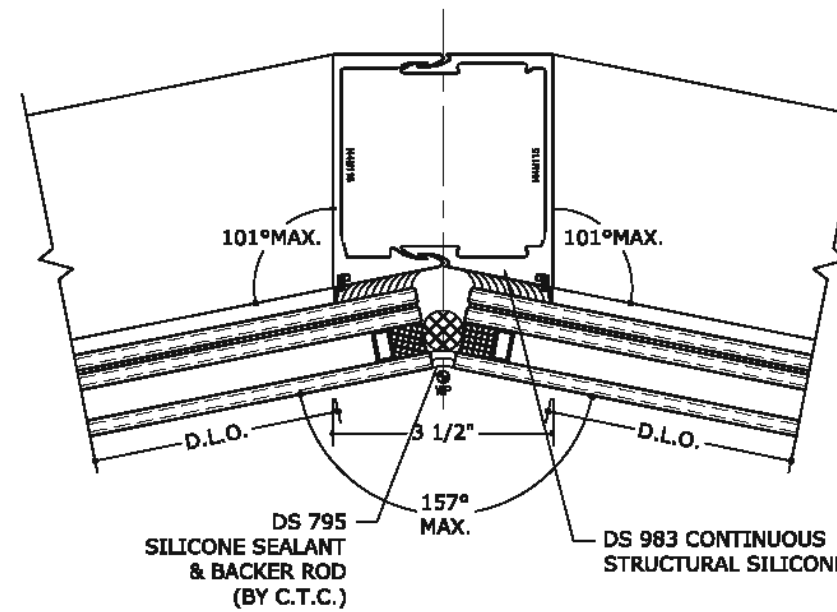

11 VERTICAL INTERMEDIATE DETAIL
 REINFORCEMENT TO BE INCLUDED AS NEEDED
 BASED UPON SITE SPECIFIC PRESSURES

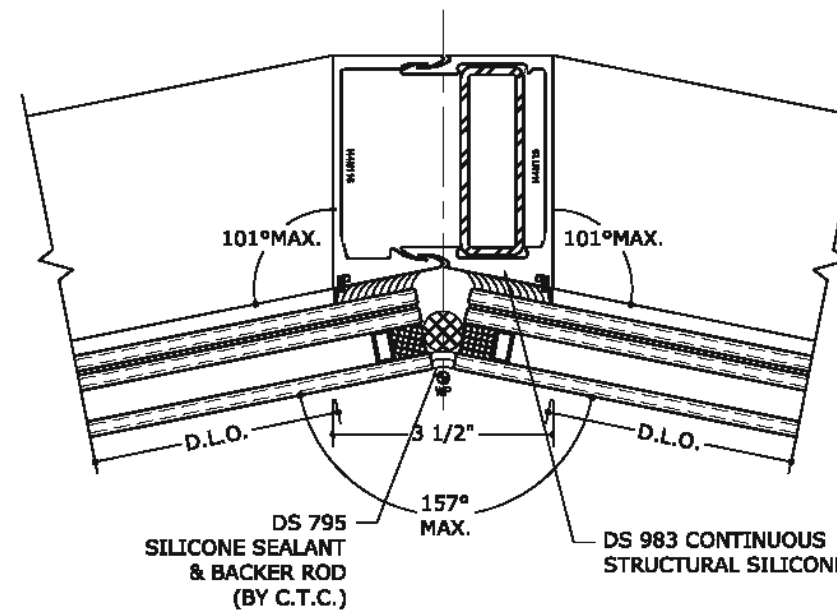

11.1 VERTICAL INTERMEDIATE DETAIL
 REINFORCEMENT TO BE INCLUDED AS NEEDED
 BASED UPON SITE SPECIFIC PRESSURES



FL#29520.4

ENGINEERING EXPRESS
 CORPORATE OFFICE:
 160 SW 12th AVE, SUITE 106
 DEERFIELD BEACH, FL 33442
 (954) 354-0660 | (866) 396-9999
 TEAM@ENGINEERINGEXPRESS.COM
 ENGINEERINGEXPRESS.COM

CRAWFORD TRACEY CORPORATION
 3301 S.W. 13th DRIVE
 DEERFIELD BEACH, FL, 33442-8101
 Phn. (954) 698-6888
 PRO-TECH 455G ALUMINUM CURTAINWALL SYSTEM
 FLORIDA STATE APPROVAL

REMARKS	DATE	CHKD	DATE
FBC 2020 UPDATE	10/19/20	JEM	AJP

THIS DOCUMENT IS THE PROPERTY OF ENGINEERING EXPRESS, AND SHALL NOT BE REPRODUCED IN WHOLE OR PART, WITHOUT WRITTEN CONSENT OF ENGINEERING EXPRESS. ALTERATIONS, ADDITIONS, OR OTHER MARKINGS TO THIS DOCUMENT ARE NOT PERMITTED AND INVALIDATE OUR CERTIFICATION.

COPYRIGHT ENGINEERING EXPRESS

20-32267

SCALE: NTS UNLESS NOTED



FL#29520.4

ENGINEERING EXPRESS
CORPORATE OFFICE:
160 SW 12th AVE, SUITE 106
DEERFIELD BEACH, FL 33442
(954) 354-0660 | (866) 996-9999
TEAM@ENGINEERINGEXPRESS.COM
ENGINEERINGEXPRESS.COM

CRAWFORD TRACEY CORPORATION
3301 S.W. 13th DRIVE
DEERFIELD BEACH, FL, 33442-8101
Phn. (954) 698-6888
PRO-TECH 455G ALUMINUM CURTAINWALL SYSTEM
FLORIDA STATE APPROVAL

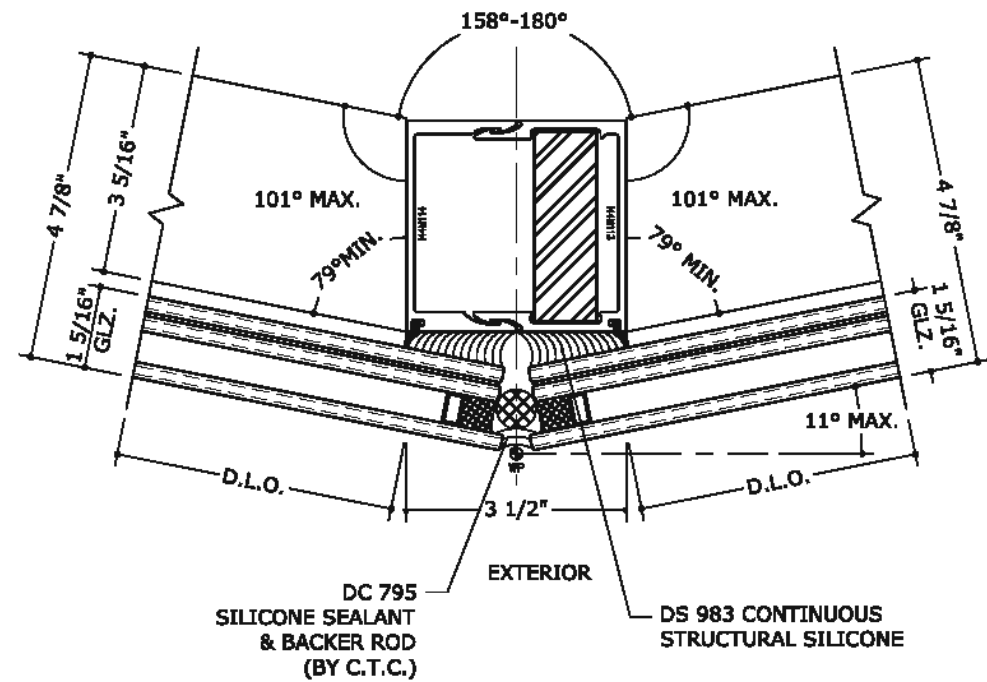

10.2 VERTICAL INTERMEDIATE DETAIL
REINFORCEMENT TO BE INCLUDED AS NEEDED
BASED UPON SITE SPECIFIC PRESSURES

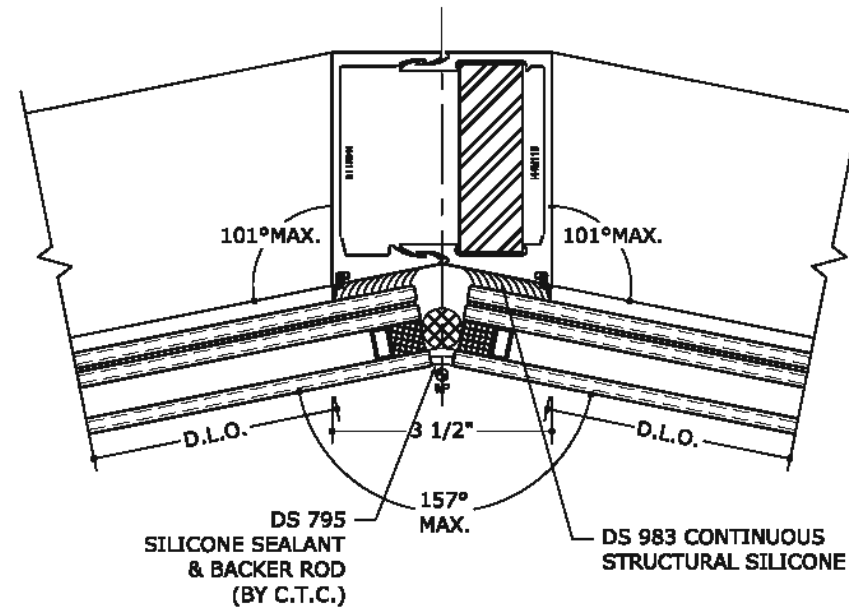

11.2 VERTICAL INTERMEDIATE DETAIL
REINFORCEMENT TO BE INCLUDED AS NEEDED
BASED UPON SITE SPECIFIC PRESSURES

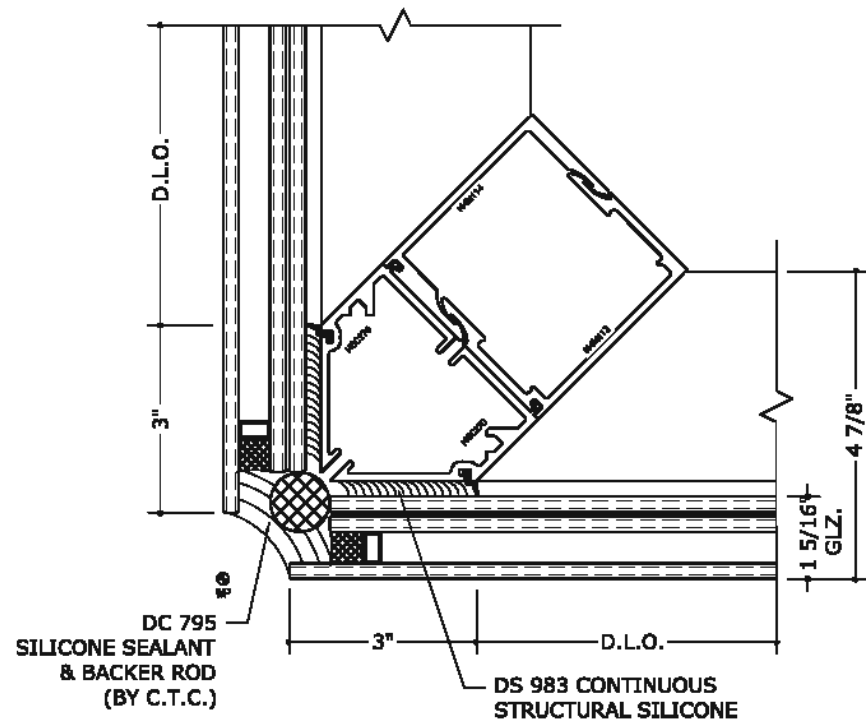

12 VERTICAL INTERMEDIATE DETAIL
REINFORCEMENT TO BE INCLUDED AS NEEDED
BASED UPON SITE SPECIFIC PRESSURES

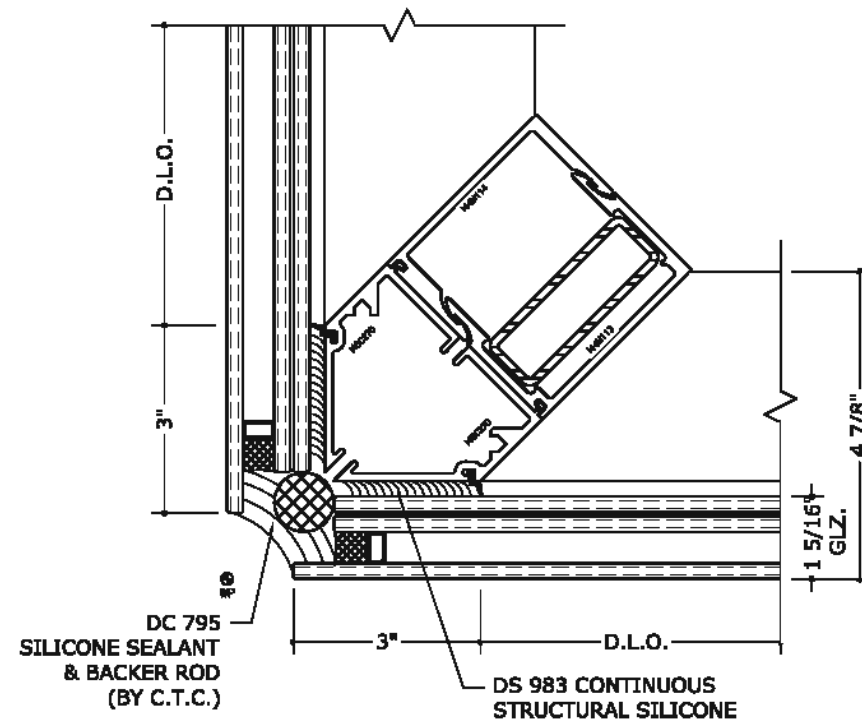

12.1 VERTICAL INTERMEDIATE DETAIL
REINFORCEMENT TO BE INCLUDED AS NEEDED
BASED UPON SITE SPECIFIC PRESSURES

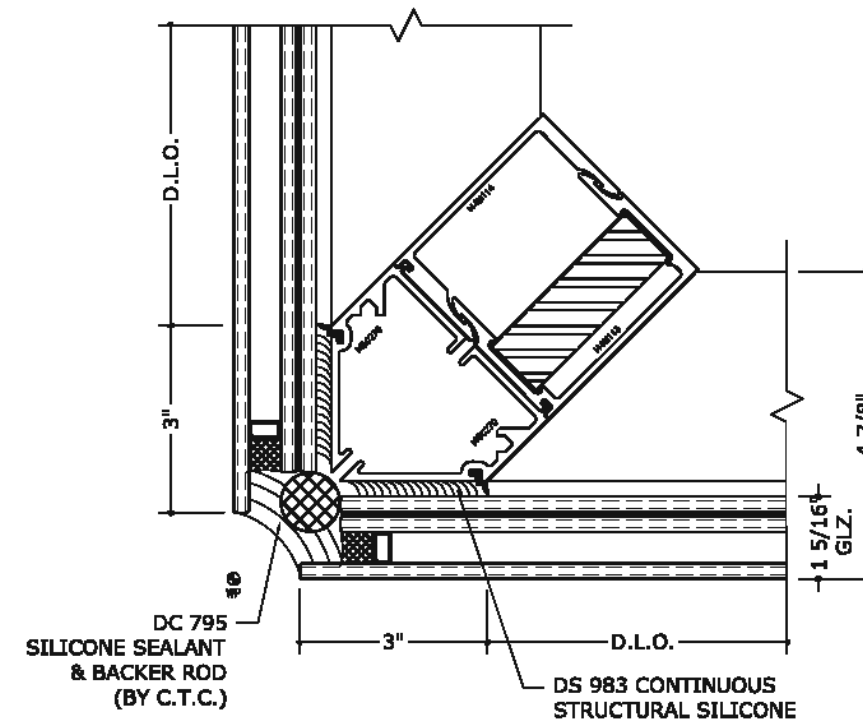

12.2 VERTICAL INTERMEDIATE DETAIL
REINFORCEMENT TO BE INCLUDED AS NEEDED
BASED UPON SITE SPECIFIC PRESSURES

REMARKS	DATE	CHKD	DATE
FBC 2020 UPDATE	10/19/20	JEM	AJP

THIS DOCUMENT IS THE PROPERTY OF ENGINEERING EXPRESS, AND SHALL NOT BE REPRODUCED IN WHOLE OR PART, WITHOUT WRITTEN CONSENT OF ENGINEERING EXPRESS. ALTERATIONS, ADDITIONS, OR OTHER MARKINGS TO THIS DOCUMENT ARE NOT PERMITTED AND INVALIDATE OUR CERTIFICATION.

COPYRIGHT ENGINEERING EXPRESS

20-32267

SCALE: NTS UNLESS NOTED

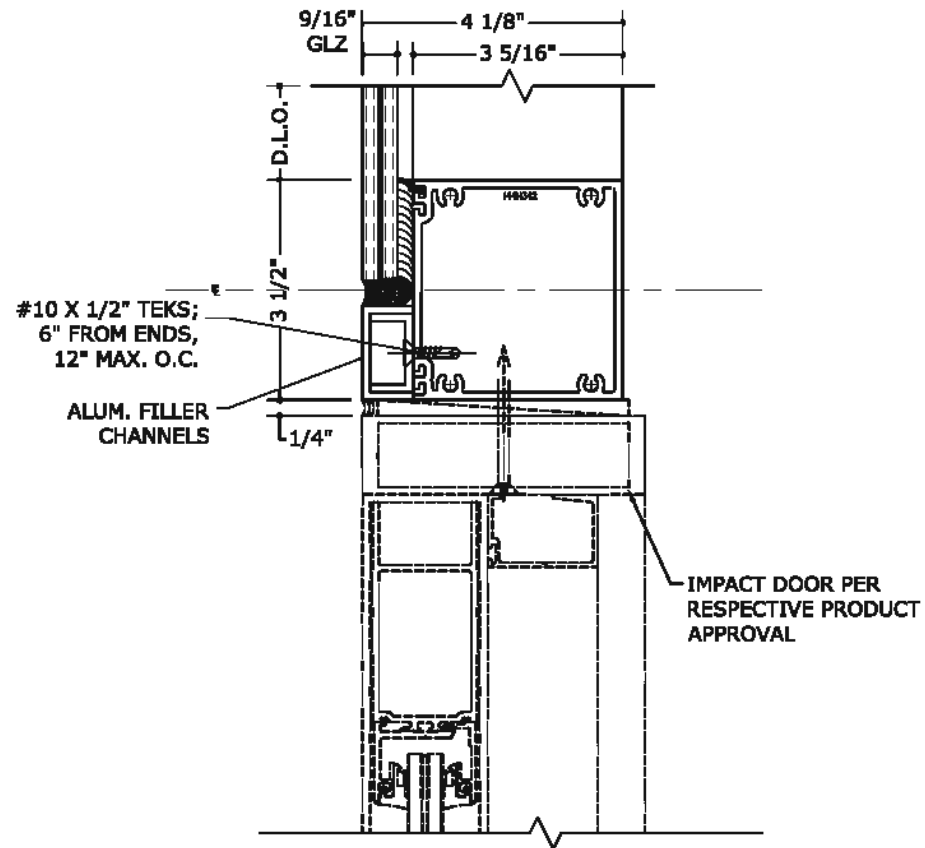

13 HORIZONTAL AT DOOR HEADER DETAIL

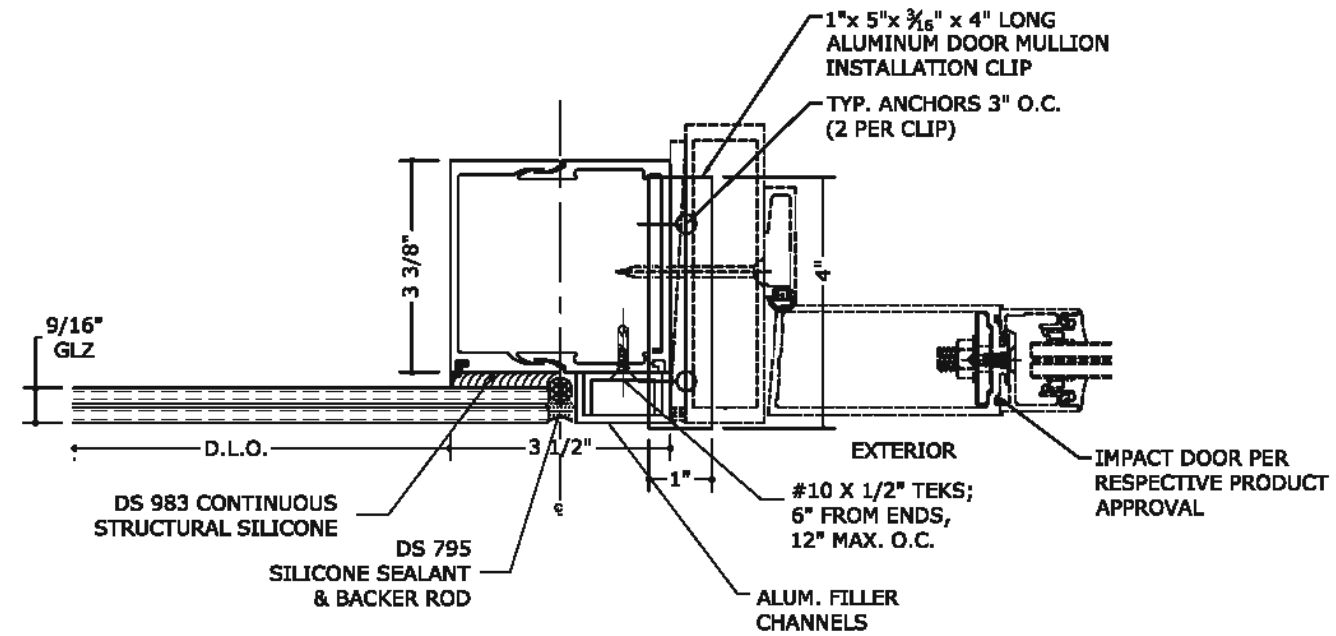

14 INTERMEDIATE VERTICAL DOOR JAMB DETAIL

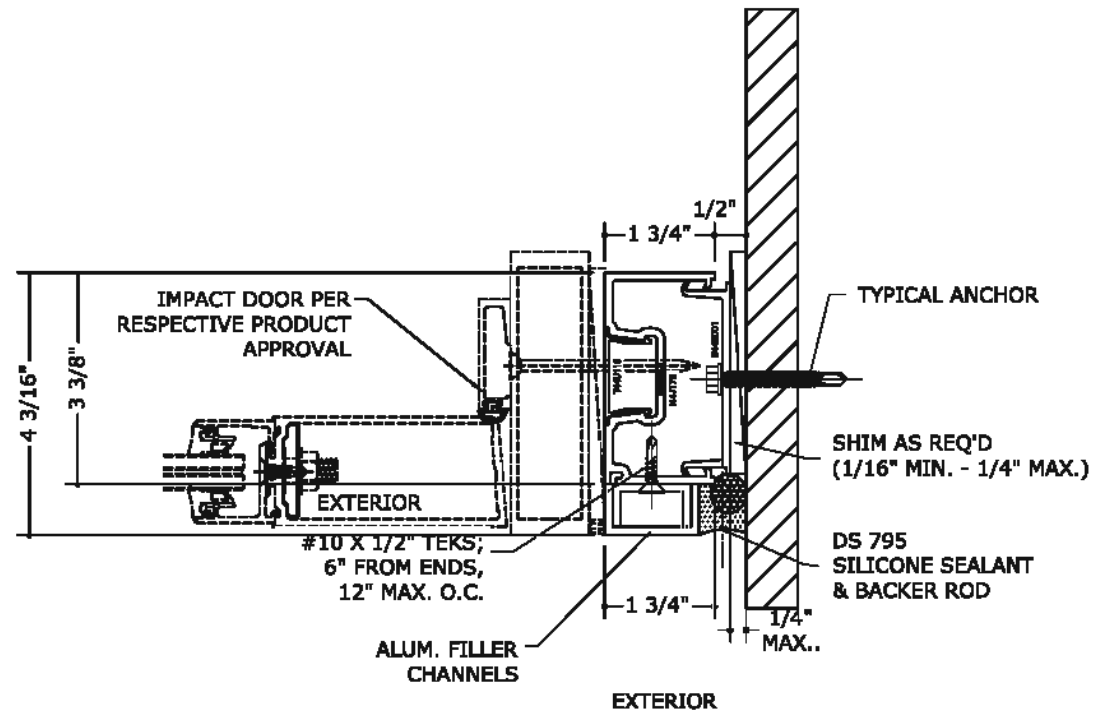

15 VERTICAL AT DOOR JAMB DETAIL

NOTE:

- SHIM SIZES GREATER THAT THE ONE SHOWN IN THE DETAILS ARE PERMITTED UNDER SITE SPECIFIC CONDITIONS.
- MODIFICATIONS TO THE ANCHORING WILL BE REQUIRED FOR THESE CONDITIONS AND SHALL BE DONE BY A PROFESSIONAL ENGINEER.



FL#29520.4

ENGINEERING EXPRESS
CORPORATE OFFICE:
160 SW 12th AVE, SUITE 106
DEERFIELD BEACH, FL 33442
(954) 354-0660 | (866) 396-9999
TEAM@ENGINEERINGEXPRESS.COM
ENGINEERINGEXPRESS.COM

CRAWFORD TRACEY CORPORATION
3301 S.W. 13th DRIVE
DEERFIELD BEACH, FL, 33442-8101
Phn. (954) 698-6888
PRO-TECH 455G ALUMINUM CURTAINWALL SYSTEM
FLORIDA STATE APPROVAL

REMARKS	DATE	CHKD	DATE
FBC 2020 UPDATE	10/19/20	JEM	AJP

THIS DOCUMENT IS THE PROPERTY OF ENGINEERING EXPRESS, AND SHALL NOT BE REPRODUCED IN WHOLE OR PART WITHOUT WRITTEN CONSENT OF ENGINEERING EXPRESS. ALTERATIONS, ADDITIONS, OR OTHER MARKINGS TO THIS DOCUMENT ARE NOT PERMITTED AND INVALIDATE OUR CERTIFICATION.

COPYRIGHT ENGINEERING EXPRESS

20-32267

SCALE: NTS UNLESS NOTED

SYSTEM 45 SG, 7 SG, 9 SG & 14 SG CURTAIN WALL SYSTEM INTEGRATED VERTICAL MULLION ALTERNATIVE DESIGN

THIS SHEET IS INTENDED TO PROVIDE APPROVAL FOR THE INTEGRATION OF CRAWFORD TRACEY CORPORATION SERIES 45SG, 7 SG, 9 SG AND 14 SG CURTAIN WALL SYSTEM

DETERMINATION OF GLASS TYPE, SIZE AND PRESSURE SHALL BE BASED OFF OF THE SMALLER SYSTEM THAT IT IS BEING INTEGRATED WITH.

- FOR EXAMPLE: WHEN TRANSITIONING FROM THE 9 SG SYSTEM TO THE 7 SG SYSTEM THE GLASS TYPE, SIZE AND PRESSURE SHALL BE IN ACCORDANCE WITH THE PROTECH 7 SG SYSTEM

DETERMINATION OF MULLION TYPE, SIZE AND PRESSURE SHALL BE BASED OFF OF THE SYSTEM WHICH THE MULLION IS BEING INTEGRATED WITH.

- FOR EXAMPLE: WHEN TRANSITIONING FROM THE 9 SG SYSTEM TO THE 7 SG SYSTEM THE MULLION TYPE, SIZE AND PRESSURE IS PERMITTED TO BE IN ACCORDANCE WITH THE PROTECH 9 SG SYSTEM

DETERMINATION OF ANCHOR TYPE, QUANTITY AND PRESSURE SHALL BE BASED OFF OF THE LARGER SYSTEM THAT IT IS BEING INTEGRATED WITH.

- FOR EXAMPLE: WHEN TRANSITIONING FROM THE 9 SG SYSTEM TO THE 7 SG SYSTEM THE ANCHOR TYPE, QUANTITY AND PRESSURE SHALL BE IN ACCORDANCE WITH THE PROTECH 9 SG SYSTEM SIZES

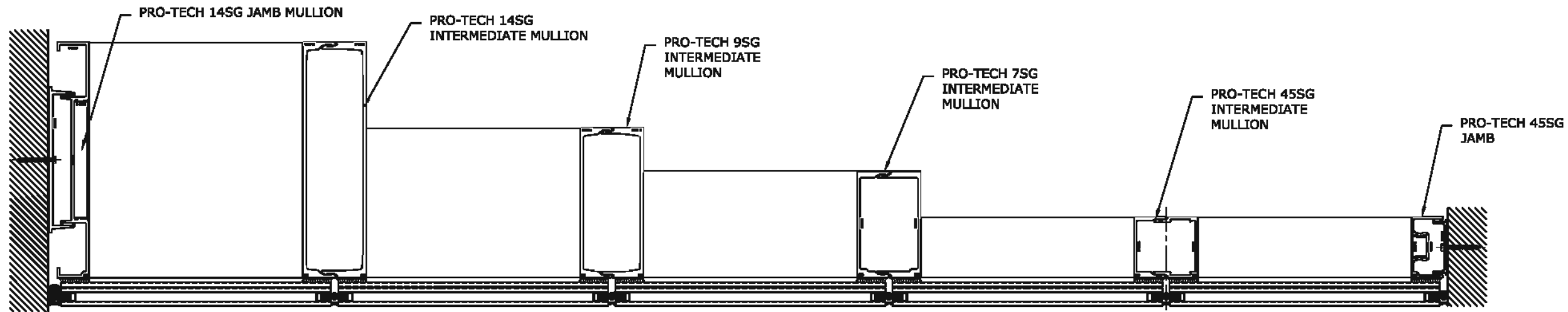

EXAMPLE PLAN VIEW FOR INTEGRATED SYSTEMS



EXAMPLE ELEVATION FOR INTEGRATED SYSTEMS

NOTE:
INTEGRATION OF PRO-TECH SYSTEMS ARE NOT REQUIRED TO BE IN THE ORDER SHOWN ON THIS PAGE. IT IS PERMITTED FOR ANY OF THE PRO-TECH SYSTEMS TO BE INTEGRATED WITH EACH OTHER, REGARDLESS OF THE SIZE.

SYSTEM 45 SG, 7 SG, 9 SG & 14 SG CURTAIN WALL SYSTEM INTEGRATED HORIZONTAL MULLION ALTERNATIVE DESIGN

THIS SHEET IS INTENDED TO PROVIDE APPROVAL FOR THE INTEGRATION OF CRAWFORD TRACEY CORPORATION SERIES 45SG, 7 SG, 9 SG AND 14 SG CURTAIN WALL SYSTEM

DETERMINATION OF GLASS TYPE, SIZE AND PRESSURE SHALL BE BASED OFF OF THE MAXIMUM ALLOWABLE WIDTH OF THE HORIZONTAL MEMBER THAT IT IS BEING INTEGRATED INTO THE VERTICAL SYSTEM .

- FOR EXAMPLE: WHEN INCORPORATING THE 7 SG SYSTEM HORIZONTAL INTO THE 9 SG SYSTEM. THE GLASS TYPE, SIZE AND PRESSURE SHALL BE IN ACCORDANCE WITH THE MAXIMUM WIDTH OF THE HORIZONTAL FROM THE PROTECH 7 SG SYSTEM

DETERMINATION OF HORIZONTAL MULLION TYPE, SIZE AND PRESSURE SHALL BE BASED OFF OF THE HORIZONTAL MULLION'S RESPECTIVE PRODUCT APPROVAL

- FOR EXAMPLE: WHEN INCORPORATING THE 7 SG SYSTEM HORIZONTAL MULLION INTO THE 9 SG SYSTEM. THE 7 SG HORIZONTAL MULLION TYPE, SIZE AND PRESSURE IS LIMITED TO THE MAXIMUM SIZE AND PRESSURE RESPECTIVE TO THE HORIZONTAL MULLION MEMBER IN THE 7 SG PRODUCT APPROVAL

MAXIMUM HORIZONTAL MEMBER SIZE PER SYSTEM	
SYSTEM	WIDTH (in.)
45 SG	72 in, <u>120 in.</u>
7 SG	72 in. , 60* in.
9 SG	72 in. , 60* in.
14 SG	94 5/8 in.

*=MAX WIDTH FOR MEMBER WITH SUNSHADE
_ = MEMBER IS A HORIZONTAL ORIENTED MULLION

FRANK BENNARDO, P.E.
PE# 0046549 CA 9885



FL#29520.4

ENGINEERING EXPRESS
CORPORATE OFFICE:
160 SW 12th AVE, SUITE 106
DEERFIELD BEACH, FL 33442
(954) 354-0660 | (866) 396-9999
TEAM@ENGINEERINGEXPRESS.COM
ENGINEERINGEXPRESS.COM

CRAWFORD TRACEY CORPORATION
3301 S.W. 13th DRIVE
DEERFIELD BEACH, FL, 33442-8101
Phn. (954) 698-6888

3301 S.W. 13th DRIVE
DEERFIELD BEACH, FL, 33442-8101
Phn. (954) 698-6888

PRO-TECH 45SG ALUMINUM CURTAINWALL SYSTEM
FLORIDA STATE APPROVAL

REMARKS	DATE	DRAWN	CHKD
FBC 2020 UPDATE	10/19/20	JEM	AJP

THIS DOCUMENT IS THE PROPERTY OF ENGINEERING EXPRESS, AND SHALL NOT BE REPRODUCED IN WHOLE OR PART WITHOUT WRITTEN CONSENT OF ENGINEERING EXPRESS. ALTERATIONS, ADDITIONS, OR OTHER MARKINGS TO THIS DOCUMENT ARE NOT PERMITTED AND INVALIDATE OUR CERTIFICATION.

COPYRIGHT ENGINEERING EXPRESS

20-32267

SCALE: NTS UNLESS NOTED

25

FASTENER SCHEDULE

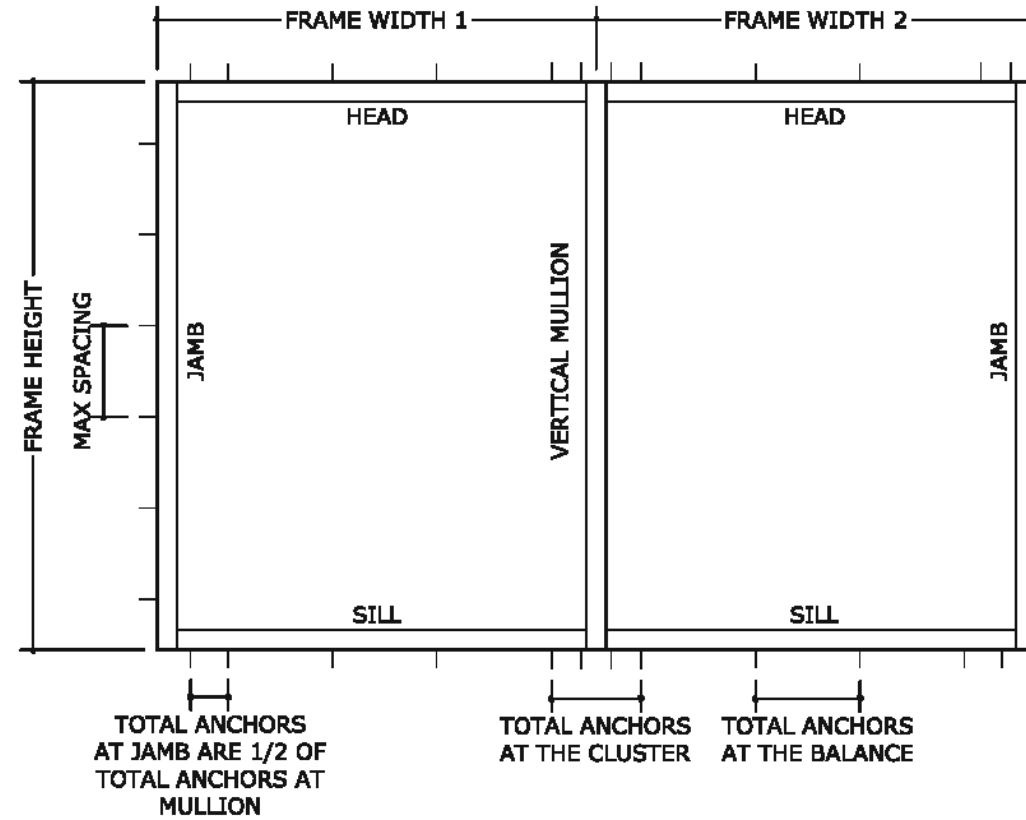

FASTENER SCHEDULE							
ANCHOR TYPE	ANCHOR DIAMETER	TYPE	MANUFACTURER	SUBSTRATE	MIN EMBEDMENT (IN)	MIN EDGE DISTANCE (IN)	SPACING (IN)
A	5/16"	ULTRACON ANCHOR	DEWALT	POURED CONCRETE 3000 PSI MIN	2	3-1/8	3-3/4" O.C.
B	5/16"-24	DRIL-FLEX HEX WASHER HEAD SELF DRILLING SCREW	DEWALT	16 GA MIN. STUD	FULL	1-1/2	4" O.C.
				1/8" ALUMINUM-6063-T6			
C	5/16"	ULTRACON ANCHOR OR LAG SCREW	DEWALT	2X WOOD BUCK G=0.55	1-1/2	1-1/2	4" O.C.

NOTE:

- 1/4" Ø ANCHORS OF ANY KIND ARE PERMITTED UNDER SITE SPECIFIC CONDITIONS.
- ANCHOR CAPACITIES BASED ON 1/4" SHIM, GREATER SHIMMING MAY BE USED UNDER SITE SPECIFIC CONDITIONS
- IF ANY OF THE ABOVE MODIFICATIONS ARE APPLIED, THE REVISED ANCHORING CONDITIONS SHALL BE DESIGNED AND APPROVED BY A LICENSED PROFESSIONAL ENGINEER & THE PRODUCT MANUFACTURER.

FRANK BENNARDO, P.E.
PE# 0046549 CA 9885



FL#29520.4

ENGINEERING EXPRESS
CORPORATE OFFICE:
160 SW 12th AVE, SUITE 106
DEERFIELD BEACH, FL 33442
(954) 354-0660 | (866) 396-9999
TEAM@ENGINEERINGEXPRESS.COM
ENGINEERINGEXPRESS.COM

CRAWFORD TRACEY CORPORATION
3301 S.W. 13th DRIVE
DEERFIELD BEACH, FL, 33442-8101
Phn. (954) 698-6888

PRO-TECH 455G ALUMINUM CURTAINWALL SYSTEM
FLORIDA STATE APPROVAL

REMARKS	DATE	DRWN	CHKD	DATE
FBC 2020 UPDATE	10/19/20	JEM	AJP	

THIS DOCUMENT IS THE PROPERTY OF ENGINEERING EXPRESS, AND SHALL NOT BE REPRODUCED IN WHOLE OR PART WITHOUT WRITTEN CONSENT OF ENGINEERING EXPRESS. ALTERATIONS, ADDITIONS, OR OTHER MARKINGS TO THIS DOCUMENT ARE NOT PERMITTED AND INVALIDATE OUR CERTIFICATION.

COPYRIGHT ENGINEERING EXPRESS®

20-32267

SCALE: NTS UNLESS NOTED

26

**MAXIMUM ALLOWABLE STRESS DESIGN PRESSURE RATING FOR
HEAD, SILL AND JAMB CONNECTIONS-ANCHOR TYPE A "MAX SHIM = 1/4"**

FRANK BENNARDO, P.E.
PE# 0046549 CA 9885



FL#29520.4

FRAME HEIGHT (ft)	TRIBUTARY (ft)	TOTAL NUMBER OF ANCHORS AT THE CLUSTER-ANCHOR TYPE A																							
		2			4			6			8			10			12			16					
		MAX PRESSURE (PSF)	HEAD/SILL MAX ANCHOR SPACING (IN)	JAMBS MAX ANCHOR SPACING (IN)	MAX PRESSURE (PSF)	HEAD/SILL MAX ANCHOR SPACING (IN)	JAMBS MAX ANCHOR SPACING (IN)	MAX PRESSURE (PSF)	HEAD/SILL MAX ANCHOR SPACING (IN)	JAMBS MAX ANCHOR SPACING (IN)	MAX PRESSURE (PSF)	HEAD/SILL MAX ANCHOR SPACING (IN)	JAMBS MAX ANCHOR SPACING (IN)	MAX PRESSURE (PSF)	HEAD/SILL MAX ANCHOR SPACING (IN)	JAMBS MAX ANCHOR SPACING (IN)	MAX PRESSURE (PSF)	HEAD/SILL MAX ANCHOR SPACING (IN)	JAMBS MAX ANCHOR SPACING (IN)	MAX PRESSURE (PSF)	HEAD/SILL MAX ANCHOR SPACING (IN)	JAMBS MAX ANCHOR SPACING (IN)			
36	24	100	12" O.C.	18" O.C.	100	12" O.C.	18" O.C.	100	12" O.C.	18" O.C.	100	12" O.C.	18" O.C.	100	12" O.C.	18" O.C.	100	12" O.C.	18" O.C.	100	12" O.C.	18" O.C.	100	12" O.C.	18" O.C.
	30	100	15" O.C.	18" O.C.	100	15" O.C.	18" O.C.	100	15" O.C.	18" O.C.	100	15" O.C.	18" O.C.	100	15" O.C.	18" O.C.	100	15" O.C.	18" O.C.	100	15" O.C.	18" O.C.	100	15" O.C.	18" O.C.
	36	100	18" O.C.	18" O.C.	100	18" O.C.	18" O.C.	100	18" O.C.	18" O.C.	100	18" O.C.	18" O.C.	100	18" O.C.	18" O.C.	100	18" O.C.	18" O.C.	100	18" O.C.	18" O.C.	100	18" O.C.	18" O.C.
	42	100	21" O.C.	18" O.C.	100	21" O.C.	18" O.C.	100	21" O.C.	18" O.C.	100	21" O.C.	18" O.C.	100	21" O.C.	18" O.C.	100	21" O.C.	18" O.C.	100	21" O.C.	18" O.C.	100	21" O.C.	18" O.C.
	48	100	24" O.C.	18" O.C.	100	24" O.C.	18" O.C.	100	24" O.C.	18" O.C.	100	24" O.C.	18" O.C.	100	24" O.C.	18" O.C.	100	24" O.C.	18" O.C.	100	24" O.C.	18" O.C.	100	24" O.C.	18" O.C.
	54	100	27" O.C.	18" O.C.	100	27" O.C.	18" O.C.	100	27" O.C.	18" O.C.	100	27" O.C.	18" O.C.	100	27" O.C.	18" O.C.	100	27" O.C.	18" O.C.	100	27" O.C.	18" O.C.	100	27" O.C.	18" O.C.
	60	100	30" O.C.	18" O.C.	100	30" O.C.	18" O.C.	100	30" O.C.	18" O.C.	100	30" O.C.	18" O.C.	100	30" O.C.	18" O.C.	100	30" O.C.	18" O.C.	100	30" O.C.	18" O.C.	100	30" O.C.	18" O.C.
	66	100	33" O.C.	18" O.C.	100	33" O.C.	18" O.C.	100	33" O.C.	18" O.C.	100	33" O.C.	18" O.C.	100	33" O.C.	18" O.C.	100	33" O.C.	18" O.C.	100	33" O.C.	18" O.C.	100	33" O.C.	18" O.C.
	72	100	36" O.C.	18" O.C.	100	36" O.C.	18" O.C.	100	36" O.C.	18" O.C.	100	36" O.C.	18" O.C.	100	36" O.C.	18" O.C.	100	36" O.C.	18" O.C.	100	36" O.C.	18" O.C.	100	36" O.C.	18" O.C.
78	100	39" O.C.	18" O.C.	100	39" O.C.	18" O.C.	100	39" O.C.	18" O.C.	100	39" O.C.	18" O.C.	100	39" O.C.	18" O.C.	100	39" O.C.	18" O.C.	100	39" O.C.	18" O.C.	100	39" O.C.	18" O.C.	
48	24	100	12" O.C.	24" O.C.	100	12" O.C.	24" O.C.	100	12" O.C.	24" O.C.	100	12" O.C.	24" O.C.	100	12" O.C.	24" O.C.	100	12" O.C.	24" O.C.	100	12" O.C.	24" O.C.	100	12" O.C.	24" O.C.
	30	100	15" O.C.	24" O.C.	100	15" O.C.	24" O.C.	100	15" O.C.	24" O.C.	100	15" O.C.	24" O.C.	100	15" O.C.	24" O.C.	100	15" O.C.	24" O.C.	100	15" O.C.	24" O.C.	100	15" O.C.	24" O.C.
	36	100	18" O.C.	24" O.C.	100	18" O.C.	24" O.C.	100	18" O.C.	24" O.C.	100	18" O.C.	24" O.C.	100	18" O.C.	24" O.C.	100	18" O.C.	24" O.C.	100	18" O.C.	24" O.C.	100	18" O.C.	24" O.C.
	42	100	21" O.C.	24" O.C.	100	21" O.C.	24" O.C.	100	21" O.C.	24" O.C.	100	21" O.C.	24" O.C.	100	21" O.C.	24" O.C.	100	21" O.C.	24" O.C.	100	21" O.C.	24" O.C.	100	21" O.C.	24" O.C.
	48	100	24" O.C.	24" O.C.	100	24" O.C.	24" O.C.	100	24" O.C.	24" O.C.	100	24" O.C.	24" O.C.	100	24" O.C.	24" O.C.	100	24" O.C.	24" O.C.	100	24" O.C.	24" O.C.	100	24" O.C.	24" O.C.
	54	100	27" O.C.	24" O.C.	100	27" O.C.	24" O.C.	100	27" O.C.	24" O.C.	100	27" O.C.	24" O.C.	100	27" O.C.	24" O.C.	100	27" O.C.	24" O.C.	100	27" O.C.	24" O.C.	100	27" O.C.	24" O.C.
	60	100	30" O.C.	24" O.C.	100	30" O.C.	24" O.C.	100	30" O.C.	24" O.C.	100	30" O.C.	24" O.C.	100	30" O.C.	24" O.C.	100	30" O.C.	24" O.C.	100	30" O.C.	24" O.C.	100	30" O.C.	24" O.C.
	66	100	33" O.C.	24" O.C.	100	33" O.C.	24" O.C.	100	33" O.C.	24" O.C.	100	33" O.C.	24" O.C.	100	33" O.C.	24" O.C.	100	33" O.C.	24" O.C.	100	33" O.C.	24" O.C.	100	33" O.C.	24" O.C.
	72	100	36" O.C.	24" O.C.	100	36" O.C.	24" O.C.	100	36" O.C.	24" O.C.	100	36" O.C.	24" O.C.	100	36" O.C.	24" O.C.	100	36" O.C.	24" O.C.	100	36" O.C.	24" O.C.	100	36" O.C.	24" O.C.
78	100	39" O.C.	24" O.C.	100	39" O.C.	24" O.C.	100	39" O.C.	24" O.C.	100	39" O.C.	24" O.C.	100	39" O.C.	24" O.C.	100	39" O.C.	24" O.C.	100	39" O.C.	24" O.C.	100	39" O.C.	24" O.C.	
60	24	100	12" O.C.	30" O.C.	100	12" O.C.	30" O.C.	100	12" O.C.	30" O.C.	100	12" O.C.	30" O.C.	100	12" O.C.	30" O.C.	100	12" O.C.	30" O.C.	100	12" O.C.	30" O.C.	100	12" O.C.	30" O.C.
	30	100	15" O.C.	30" O.C.	100	15" O.C.	30" O.C.	100	15" O.C.	30" O.C.	100	15" O.C.	30" O.C.	100	15" O.C.	30" O.C.	100	15" O.C.	30" O.C.	100	15" O.C.	30" O.C.	100	15" O.C.	30" O.C.
	36	100	18" O.C.	30" O.C.	100	18" O.C.	30" O.C.	100	18" O.C.	30" O.C.	100	18" O.C.	30" O.C.	100	18" O.C.	30" O.C.	100	18" O.C.	30" O.C.	100	18" O.C.	30" O.C.	100	18" O.C.	30" O.C.
	42	100	21" O.C.	30" O.C.	100	21" O.C.	30" O.C.	100	21" O.C.	30" O.C.	100	21" O.C.	30" O.C.	100	21" O.C.	30" O.C.	100	21" O.C.	30" O.C.	100	21" O.C.	30" O.C.	100	21" O.C.	30" O.C.
	48	100	24" O.C.	30" O.C.	100	24" O.C.	30" O.C.	100	24" O.C.	30" O.C.	100	24" O.C.	30" O.C.	100	24" O.C.	30" O.C.	100	24" O.C.	30" O.C.	100	24" O.C.	30" O.C.	100	24" O.C.	30" O.C.
	54	100	27" O.C.	30" O.C.	100	27" O.C.	30" O.C.	100	27" O.C.	30" O.C.	100	27" O.C.	30" O.C.	100	27" O.C.	30" O.C.	100	27" O.C.	30" O.C.	100	27" O.C.	30" O.C.	100	27" O.C.	30" O.C.
	60	100	30" O.C.	30" O.C.	100	30" O.C.	30" O.C.	100	30" O.C.	30" O.C.	100	30" O.C.	30" O.C.	100	30" O.C.	30" O.C.	100	30" O.C.	30" O.C.	100	30" O.C.	30" O.C.	100	30" O.C.	30" O.C.
	66	100	33" O.C.	30" O.C.	100	33" O.C.	30" O.C.	100	33" O.C.	30" O.C.	100	33" O.C.	30" O.C.	100	33" O.C.	30" O.C.	100	33" O.C.	30" O.C.	100	33" O.C.	30" O.C.	100	33" O.C.	30" O.C.
	72	100	36" O.C.	30" O.C.	100	36" O.C.	30" O.C.	100	36" O.C.	30" O.C.	100	36" O.C.	30" O.C.	100	36" O.C.	30" O.C.	100	36" O.C.	30" O.C.	100	36" O.C.	30" O.C.	100	36" O.C.	30" O.C.
78	100	39" O.C.	30" O.C.	100	39" O.C.	30" O.C.	100	39" O.C.	30" O.C.	100	39" O.C.	30" O.C.	100	39" O.C.	30" O.C.	100	39" O.C.	30" O.C.	100	39" O.C.	30" O.C.	100	39" O.C.	30" O.C.	
72	24	100	12" O.C.	36" O.C.	100	12" O.C.	36" O.C.	100	12" O.C.	36" O.C.	100	12" O.C.	36" O.C.	100	12" O.C.	36" O.C.	100	12" O.C.	36" O.C.	100	12" O.C.	36" O.C.	100	12" O.C.	36" O.C.
	30	100	15" O.C.	36" O.C.	100	15" O.C.	36" O.C.	100	15" O.C.	36" O.C.	100	15" O.C.	36" O.C.	100	15" O.C.	36" O.C.	100	15" O.C.	36" O.C.	100	15" O.C.	36" O.C.	100	15" O.C.	36" O.C.
	36	100	18" O.C.	36" O.C.	100	18" O.C.	36" O.C.	100	18" O.C.	36" O.C.	100	18" O.C.	36" O.C.	100	18" O.C.	36" O.C.	100	18" O.C.	36" O.C.	100	18" O.C.	36" O.C.	100	18" O.C.	36" O.C.
	42	100	21" O.C.	36" O.C.	100	21" O.C.	36" O.C.	100	21" O.C.	36" O.C.	100	21" O.C.	36" O.C.	100	21" O.C.	36" O.C.	100	21" O.C.	36" O.C.	100	21" O.C.	36" O.C.	100	21" O.C.	36" O.C.
	48	100	24" O.C.	36" O.C.	100	24" O.C.	36" O.C.	100	24" O.C.	36" O.C.	100	24" O.C.	36" O.C.	100	24" O.C.	36" O.C.	100	24" O.C.	36" O.C.	100	24" O.C.	36" O.C.	100	24" O.C.	36" O.C.
	54	100	27" O.C.	36" O.C.	100	27" O.C.	36" O.C.	100	27" O.C.	36" O.C.	100	27" O.C.	36" O.C.	100	27" O.C.	36" O.C.	100	27" O.C.	36" O.C.	100	27" O.C.	36" O.C.	100	27" O.C.	36" O.C.
	60	74	30" O.C.	36" O.C.	100	30" O.C.	36" O.C.	100	30" O.C.	36" O.C.	100	30" O.C.	36" O.C.	100	30" O.C.	36" O.C.	100	30" O.C.	36" O.C.	100	30" O.C.	36" O.C.	100	30" O.C.	36" O.C.
	66	72	33" O.C.	36" O.C.	100	33" O.C.	36" O.C.	100	33" O.C.	36" O.C.	100	33" O.C.	36" O.C.	100	33" O.C.	36" O.C.	100	33" O.C.	36" O.C.	100	33" O.C.	36" O.C.	100	33" O.C.	36" O.C.
	72	72	36" O.C.	36" O.C.	100	36" O.C.	36" O.C.	100	36" O.C.	36" O.C.	100	36" O.C.	36" O.C.	100	36" O.C.	36" O.C.	100	36" O.C.	36" O.C.	100	36" O.C.	36" O.C.	100	36" O.C.	36" O.C.
78	72	39" O.C.	36" O.C.	100	39" O.C.	36" O.C.	100	39" O.C.	36" O.C.	100	39" O.C.	36" O.C.	100	39" O.C.	36" O.C.	100	39" O.C.	36" O.C.	100	39" O.C.	36" O.C.	100	39" O.C.	36" O.C.	

ENGINEERING EXPRESS
CORPORATE OFFICE:
160 SW 12th AVE, SUITE 106
DEERFIELD BEACH, FL 33442
(954) 354-0660 | (866) 396-9999
TEAM@ENGINEERINGEXPRESS.COM
ENGINEERINGEXPRESS.COM

CRAWFORD TRACEY CORPORATION
3301 S.W. 13th DRIVE
DEERFIELD BEACH, FL, 33442-8101
Phn. (954) 698-6888

PRO-TECH 455G ALUMINUM CURTAINWALL SYSTEM
FLORIDA STATE APPROVAL

REMARKS	DATE	DRAWN	CHKD
FBC 2020 UPDATE	10/19/20	JEM	AJP

THIS DOCUMENT IS THE PROPERTY OF ENGINEERING EXPRESS, AND SHALL NOT BE REPRODUCED IN WHOLE OR PART WITHOUT WRITTEN CONSENT OF ENGINEERING EXPRESS. ALTERATIONS, ADDITIONS, OR OTHER MARKINGS TO THIS DOCUMENT ARE NOT PERMITTED AND INVALIDATE OUR CERTIFICATION.

COPYRIGHT ENGINEERING EXPRESS®
20-32267
SCALE: NTS UNLESS NOTED
27

**MAXIMUM ALLOWABLE STRESS DESIGN PRESSURE RATING FOR
HEAD, SILL AND JAMB CONNECTIONS-ANCHOR TYPE A "MAX SHIM = 1/4"**

FRANK BENNARDO, P.E.
PE# 0046549 CA 9885



FL#29520.4

FRAME HEIGHT (H)	TRIBUTARY (W)	TOTAL NUMBER OF ANCHORS AT THE CLUSTER-ANCHOR TYPE A																							
		2			4			6			8			10			12			16					
		MAX PRESSURE (PSF)	HEAD/SILL MAX ANCHOR SPACING (IN)	JAMBS MAX ANCHOR SPACING (IN)	MAX PRESSURE (PSF)	HEAD/SILL MAX ANCHOR SPACING (IN)	JAMBS MAX ANCHOR SPACING (IN)	MAX PRESSURE (PSF)	HEAD/SILL MAX ANCHOR SPACING (IN)	JAMBS MAX ANCHOR SPACING (IN)	MAX PRESSURE (PSF)	HEAD/SILL MAX ANCHOR SPACING (IN)	JAMBS MAX ANCHOR SPACING (IN)	MAX PRESSURE (PSF)	HEAD/SILL MAX ANCHOR SPACING (IN)	JAMBS MAX ANCHOR SPACING (IN)	MAX PRESSURE (PSF)	HEAD/SILL MAX ANCHOR SPACING (IN)	JAMBS MAX ANCHOR SPACING (IN)	MAX PRESSURE (PSF)	HEAD/SILL MAX ANCHOR SPACING (IN)	JAMBS MAX ANCHOR SPACING (IN)			
84	24	100	12" O.C.	42" O.C.	100	12" O.C.	42" O.C.	100	12" O.C.	42" O.C.	100	12" O.C.	42" O.C.	100	12" O.C.	42" O.C.	100	12" O.C.	42" O.C.	100	12" O.C.	42" O.C.	100	12" O.C.	42" O.C.
	30	100	15" O.C.	42" O.C.	100	15" O.C.	42" O.C.	100	15" O.C.	42" O.C.	100	15" O.C.	42" O.C.	100	15" O.C.	42" O.C.	100	15" O.C.	42" O.C.	100	15" O.C.	42" O.C.	100	15" O.C.	42" O.C.
	36	100	18" O.C.	42" O.C.	100	18" O.C.	42" O.C.	100	18" O.C.	42" O.C.	100	18" O.C.	42" O.C.	100	18" O.C.	42" O.C.	100	18" O.C.	42" O.C.	100	18" O.C.	42" O.C.	100	18" O.C.	42" O.C.
	42	100	21" O.C.	42" O.C.	100	21" O.C.	42" O.C.	100	21" O.C.	42" O.C.	100	21" O.C.	42" O.C.	100	21" O.C.	42" O.C.	100	21" O.C.	42" O.C.	100	21" O.C.	42" O.C.	100	21" O.C.	42" O.C.
	48	100	24" O.C.	42" O.C.	100	24" O.C.	42" O.C.	100	24" O.C.	42" O.C.	100	24" O.C.	42" O.C.	100	24" O.C.	42" O.C.	100	24" O.C.	42" O.C.	100	24" O.C.	42" O.C.	100	24" O.C.	42" O.C.
	54	100	27" O.C.	42" O.C.	100	27" O.C.	42" O.C.	100	27" O.C.	42" O.C.	100	27" O.C.	42" O.C.	100	27" O.C.	42" O.C.	100	27" O.C.	42" O.C.	100	27" O.C.	42" O.C.	100	27" O.C.	42" O.C.
	60	57	30" O.C.	42" O.C.	100	30" O.C.	42" O.C.	100	30" O.C.	42" O.C.	100	30" O.C.	42" O.C.	100	30" O.C.	42" O.C.	100	30" O.C.	42" O.C.	100	30" O.C.	42" O.C.	100	30" O.C.	42" O.C.
	66	55	33" O.C.	42" O.C.	100	33" O.C.	42" O.C.	100	33" O.C.	42" O.C.	100	33" O.C.	42" O.C.	100	33" O.C.	42" O.C.	100	33" O.C.	42" O.C.	100	33" O.C.	42" O.C.	100	33" O.C.	42" O.C.
72	54	36" O.C.	42" O.C.	100	36" O.C.	42" O.C.	100	36" O.C.	42" O.C.	100	36" O.C.	42" O.C.	100	36" O.C.	42" O.C.	100	36" O.C.	42" O.C.	100	36" O.C.	42" O.C.	100	36" O.C.	42" O.C.	
78	53	39" O.C.	42" O.C.	100	39" O.C.	42" O.C.	100	39" O.C.	42" O.C.	100	39" O.C.	42" O.C.	100	39" O.C.	42" O.C.	100	39" O.C.	42" O.C.	100	39" O.C.	42" O.C.	100	39" O.C.	42" O.C.	
96	24	100	12" O.C.	48" O.C.	100	12" O.C.	48" O.C.	100	12" O.C.	48" O.C.	100	12" O.C.	48" O.C.	100	12" O.C.	48" O.C.	100	12" O.C.	48" O.C.	100	12" O.C.	48" O.C.	100	12" O.C.	48" O.C.
	30	100	15" O.C.	48" O.C.	100	15" O.C.	48" O.C.	100	15" O.C.	48" O.C.	100	15" O.C.	48" O.C.	100	15" O.C.	48" O.C.	100	15" O.C.	48" O.C.	100	15" O.C.	48" O.C.	100	15" O.C.	48" O.C.
	36	100	18" O.C.	48" O.C.	100	18" O.C.	48" O.C.	100	18" O.C.	48" O.C.	100	18" O.C.	48" O.C.	100	18" O.C.	48" O.C.	100	18" O.C.	48" O.C.	100	18" O.C.	48" O.C.	100	18" O.C.	48" O.C.
	42	100	21" O.C.	48" O.C.	100	21" O.C.	48" O.C.	100	21" O.C.	48" O.C.	100	21" O.C.	48" O.C.	100	21" O.C.	48" O.C.	100	21" O.C.	48" O.C.	100	21" O.C.	48" O.C.	100	21" O.C.	48" O.C.
	48	100	24" O.C.	48" O.C.	100	24" O.C.	48" O.C.	100	24" O.C.	48" O.C.	100	24" O.C.	48" O.C.	100	24" O.C.	48" O.C.	100	24" O.C.	48" O.C.	100	24" O.C.	48" O.C.	100	24" O.C.	48" O.C.
	54	100	27" O.C.	48" O.C.	100	27" O.C.	48" O.C.	100	27" O.C.	48" O.C.	100	27" O.C.	48" O.C.	100	27" O.C.	48" O.C.	100	27" O.C.	48" O.C.	100	27" O.C.	48" O.C.	100	27" O.C.	48" O.C.
	60	47	30" O.C.	48" O.C.	94	30" O.C.	48" O.C.	100	30" O.C.	32" O.C.	100	30" O.C.	32" O.C.	100	30" O.C.	32" O.C.	100	30" O.C.	32" O.C.	100	30" O.C.	32" O.C.	100	30" O.C.	32" O.C.
	66	45	33" O.C.	48" O.C.	90	33" O.C.	48" O.C.	100	33" O.C.	32" O.C.	100	33" O.C.	32" O.C.	100	33" O.C.	32" O.C.	100	33" O.C.	32" O.C.	100	33" O.C.	32" O.C.	100	33" O.C.	32" O.C.
72	43	36" O.C.	48" O.C.	86	36" O.C.	48" O.C.	100	36" O.C.	32" O.C.	100	36" O.C.	32" O.C.	100	36" O.C.	32" O.C.	100	36" O.C.	32" O.C.	100	36" O.C.	32" O.C.	100	36" O.C.	32" O.C.	
78	42	39" O.C.	48" O.C.	84	39" O.C.	48" O.C.	100	39" O.C.	32" O.C.	100	39" O.C.	32" O.C.	100	39" O.C.	32" O.C.	100	39" O.C.	32" O.C.	100	39" O.C.	32" O.C.	100	39" O.C.	32" O.C.	
108	24	100	12" O.C.	54" O.C.	100	12" O.C.	54" O.C.	100	12" O.C.	54" O.C.	100	12" O.C.	54" O.C.	100	12" O.C.	54" O.C.	100	12" O.C.	54" O.C.	100	12" O.C.	54" O.C.	100	12" O.C.	54" O.C.
	30	100	15" O.C.	54" O.C.	100	15" O.C.	54" O.C.	100	15" O.C.	54" O.C.	100	15" O.C.	54" O.C.	100	15" O.C.	54" O.C.	100	15" O.C.	54" O.C.	100	15" O.C.	54" O.C.	100	15" O.C.	54" O.C.
	36	100	18" O.C.	54" O.C.	100	18" O.C.	54" O.C.	100	18" O.C.	54" O.C.	100	18" O.C.	54" O.C.	100	18" O.C.	54" O.C.	100	18" O.C.	54" O.C.	100	18" O.C.	54" O.C.	100	18" O.C.	54" O.C.
	42	100	21" O.C.	54" O.C.	100	21" O.C.	54" O.C.	100	21" O.C.	54" O.C.	100	21" O.C.	54" O.C.	100	21" O.C.	54" O.C.	100	21" O.C.	54" O.C.	100	21" O.C.	54" O.C.	100	21" O.C.	54" O.C.
	48	92	24" O.C.	54" O.C.	100	24" O.C.	54" O.C.	100	24" O.C.	54" O.C.	100	24" O.C.	54" O.C.	100	24" O.C.	54" O.C.	100	24" O.C.	54" O.C.	100	24" O.C.	54" O.C.	100	24" O.C.	54" O.C.
	54	85	27" O.C.	54" O.C.	100	27" O.C.	54" O.C.	100	27" O.C.	54" O.C.	100	27" O.C.	54" O.C.	100	27" O.C.	54" O.C.	100	27" O.C.	54" O.C.	100	27" O.C.	54" O.C.	100	27" O.C.	54" O.C.
	60	40	30" O.C.	54" O.C.	80	30" O.C.	54" O.C.	100	30" O.C.	36" O.C.	100	30" O.C.	36" O.C.	100	30" O.C.	36" O.C.	100	30" O.C.	36" O.C.	100	30" O.C.	36" O.C.	100	30" O.C.	36" O.C.
	66	37	33" O.C.	54" O.C.	75	33" O.C.	54" O.C.	100	33" O.C.	36" O.C.	100	33" O.C.	36" O.C.	100	33" O.C.	36" O.C.	100	33" O.C.	36" O.C.	100	33" O.C.	36" O.C.	100	33" O.C.	36" O.C.
72	36	36" O.C.	54" O.C.	72	36" O.C.	54" O.C.	100	36" O.C.	36" O.C.	100	36" O.C.	36" O.C.	100	36" O.C.	36" O.C.	100	36" O.C.	36" O.C.	100	36" O.C.	36" O.C.	100	36" O.C.	36" O.C.	
78	34	39" O.C.	54" O.C.	69	39" O.C.	54" O.C.	100	39" O.C.	36" O.C.	100	39" O.C.	36" O.C.	100	39" O.C.	36" O.C.	100	39" O.C.	36" O.C.	100	39" O.C.	36" O.C.	100	39" O.C.	36" O.C.	
120	24	100	12" O.C.	60" O.C.	100	12" O.C.	60" O.C.	100	12" O.C.	60" O.C.	100	12" O.C.	60" O.C.	100	12" O.C.	60" O.C.	100	12" O.C.	60" O.C.	100	12" O.C.	60" O.C.	100	12" O.C.	60" O.C.
	30	100	15" O.C.	60" O.C.	100	15" O.C.	60" O.C.	100	15" O.C.	60" O.C.	100	15" O.C.	60" O.C.	100	15" O.C.	60" O.C.	100	15" O.C.	60" O.C.	100	15" O.C.	60" O.C.	100	15" O.C.	60" O.C.
	36	100	18" O.C.	60" O.C.	100	18" O.C.	60" O.C.	100	18" O.C.	60" O.C.	100	18" O.C.	60" O.C.	100	18" O.C.	60" O.C.	100	18" O.C.	60" O.C.	100	18" O.C.	60" O.C.	100	18" O.C.	60" O.C.
	42	90	21" O.C.	60" O.C.	100	21" O.C.	60" O.C.	100	21" O.C.	60" O.C.	100	21" O.C.	60" O.C.	100	21" O.C.	60" O.C.	100	21" O.C.	60" O.C.	100	21" O.C.	60" O.C.	100	21" O.C.	60" O.C.
	48	81	24" O.C.	60" O.C.	100	24" O.C.	60" O.C.	100	24" O.C.	60" O.C.	100	24" O.C.	60" O.C.	100	24" O.C.	60" O.C.	100	24" O.C.	60" O.C.	100	24" O.C.	60" O.C.	100	24" O.C.	60" O.C.
	54	74	27" O.C.	60" O.C.	100	27" O.C.	60" O.C.	100	27" O.C.	60" O.C.	100	27" O.C.	60" O.C.	100	27" O.C.	60" O.C.	100	27" O.C.	60" O.C.	100	27" O.C.	60" O.C.	100	27" O.C.	60" O.C.
	60	34	30" O.C.	60" O.C.	69	30" O.C.	60" O.C.	100	30" O.C.	40" O.C.	100	30" O.C.	40" O.C.	100	30" O.C.	40" O.C.	100	30" O.C.	40" O.C.	100	30" O.C.	40" O.C.	100	30" O.C.	40" O.C.
	66	32	33" O.C.	60" O.C.	65	33" O.C.	60" O.C.	97	33" O.C.	40" O.C.	100	33" O.C.	40" O.C.	100	33" O.C.	40" O.C.	100	33" O.C.	40" O.C.	100	33" O.C.	40" O.C.	100	33" O.C.	40" O.C.
72	30	36" O.C.	60" O.C.	61	36" O.C.	60" O.C.	92	36" O.C.	40" O.C.	100	36" O.C.	40" O.C.	100	36" O.C.	40" O.C.	100	36" O.C.	40" O.C.	100	36" O.C.	40" O.C.	100	36" O.C.	40" O.C.	
78	29	39" O.C.	60" O.C.	59	39" O.C.	60" O.C.	88	39" O.C.	40" O.C.	100	39" O.C.	40" O.C.	100	39" O.C.	40" O.C.	100	39" O.C.	40" O.C.	100	39" O.C.	40" O.C.	100	39" O.C.	40" O.C.	

ENGINEERING EXPRESS
CORPORATE OFFICE:
160 SW 12th AVE, SUITE 106
DEERFIELD BEACH, FL 33442
(954) 354-0660 | (866) 396-9999
TEAM@ENGINEERINGEXPRESS.COM
ENGINEERINGEXPRESS.COM

CRAWFORD TRACEY CORPORATION
3301 S.W. 13th DRIVE
DEERFIELD BEACH, FL, 33442-8101
Phn. (954) 698-6888
PRO-TECH 4-SSG ALUMINUM CURTAINWALL SYSTEM
FLORIDA STATE APPROVAL

REMARKS	DATE	CHKD	DATE	CHKD
FBC 2020 UPDATE	10/19/20	JEM	AJP	

THIS DOCUMENT IS THE PROPERTY OF ENGINEERING EXPRESS, AND SHALL NOT BE REPRODUCED IN WHOLE OR PART WITHOUT WRITTEN CONSENT OF ENGINEERING EXPRESS. ALTERATIONS, ADDITIONS, OR OTHER MARKINGS TO THIS DOCUMENT ARE NOT PERMITTED AND INVALIDATE OUR CERTIFICATION.

COPYRIGHT ENGINEERING EXPRESS®
20-32267
SCALE: NTS UNLESS NOTED
28

**MAXIMUM ALLOWABLE STRESS DESIGN PRESSURE RATING FOR
HEAD, SILL AND JAMB CONNECTIONS-ANCHOR TYPE B "MAX SHIM = 1/4"**

FRANK BENNARDO, P.E.
PE# 0046549 CA 9885



FL#29520.4

FRAME HEIGHT (H)	TRIBUTARY (W)	TOTAL NUMBER OF ANCHORS AT THE CLUSTER-ANCHOR TYPE B																							
		2			4			6			8			10			12			16					
		MAX PRESSURE (PSF)	HEAD/SILL MAX ANCHOR SPACING (IN)	JAMBS MAX ANCHOR SPACING (IN)	MAX PRESSURE (PSF)	HEAD/SILL MAX ANCHOR SPACING (IN)	JAMBS MAX ANCHOR SPACING (IN)	MAX PRESSURE (PSF)	HEAD/SILL MAX ANCHOR SPACING (IN)	JAMBS MAX ANCHOR SPACING (IN)	MAX PRESSURE (PSF)	HEAD/SILL MAX ANCHOR SPACING (IN)	JAMBS MAX ANCHOR SPACING (IN)	MAX PRESSURE (PSF)	HEAD/SILL MAX ANCHOR SPACING (IN)	JAMBS MAX ANCHOR SPACING (IN)	MAX PRESSURE (PSF)	HEAD/SILL MAX ANCHOR SPACING (IN)	JAMBS MAX ANCHOR SPACING (IN)	MAX PRESSURE (PSF)	HEAD/SILL MAX ANCHOR SPACING (IN)	JAMBS MAX ANCHOR SPACING (IN)			
84	24	100	12" O.C.	42" O.C.	100	12" O.C.	42" O.C.	100	12" O.C.	42" O.C.	100	12" O.C.	42" O.C.	100	12" O.C.	42" O.C.	100	12" O.C.	42" O.C.	100	12" O.C.	42" O.C.	100	12" O.C.	42" O.C.
	30	100	15" O.C.	42" O.C.	100	15" O.C.	42" O.C.	100	15" O.C.	42" O.C.	100	15" O.C.	42" O.C.	100	15" O.C.	42" O.C.	100	15" O.C.	42" O.C.	100	15" O.C.	42" O.C.	100	15" O.C.	42" O.C.
	36	100	18" O.C.	42" O.C.	100	18" O.C.	42" O.C.	100	18" O.C.	42" O.C.	100	18" O.C.	42" O.C.	100	18" O.C.	42" O.C.	100	18" O.C.	42" O.C.	100	18" O.C.	42" O.C.	100	18" O.C.	42" O.C.
	42	100	21" O.C.	42" O.C.	100	21" O.C.	42" O.C.	100	21" O.C.	42" O.C.	100	21" O.C.	42" O.C.	100	21" O.C.	42" O.C.	100	21" O.C.	42" O.C.	100	21" O.C.	42" O.C.	100	21" O.C.	42" O.C.
	48	100	24" O.C.	42" O.C.	100	24" O.C.	42" O.C.	100	24" O.C.	42" O.C.	100	24" O.C.	42" O.C.	100	24" O.C.	42" O.C.	100	24" O.C.	42" O.C.	100	24" O.C.	42" O.C.	100	24" O.C.	42" O.C.
	54	100	27" O.C.	42" O.C.	100	27" O.C.	42" O.C.	100	27" O.C.	42" O.C.	100	27" O.C.	42" O.C.	100	27" O.C.	42" O.C.	100	27" O.C.	42" O.C.	100	27" O.C.	42" O.C.	100	27" O.C.	42" O.C.
	60	52	30" O.C.	42" O.C.	100	30" O.C.	42" O.C.	100	30" O.C.	42" O.C.	100	30" O.C.	42" O.C.	100	30" O.C.	42" O.C.	100	30" O.C.	42" O.C.	100	30" O.C.	42" O.C.	100	30" O.C.	42" O.C.
	66	50	33" O.C.	42" O.C.	100	33" O.C.	42" O.C.	100	33" O.C.	42" O.C.	100	33" O.C.	42" O.C.	100	33" O.C.	42" O.C.	100	33" O.C.	42" O.C.	100	33" O.C.	42" O.C.	100	33" O.C.	42" O.C.
96	72	48	36" O.C.	42" O.C.	97	36" O.C.	42" O.C.	100	36" O.C.	28" O.C.	100	36" O.C.	28" O.C.	100	36" O.C.	28" O.C.	100	36" O.C.	28" O.C.	100	36" O.C.	28" O.C.	100	36" O.C.	28" O.C.
	78	48	39" O.C.	42" O.C.	96	39" O.C.	42" O.C.	100	39" O.C.	28" O.C.	100	39" O.C.	28" O.C.	100	39" O.C.	28" O.C.	100	39" O.C.	28" O.C.	100	39" O.C.	28" O.C.	100	39" O.C.	28" O.C.
	24	100	12" O.C.	48" O.C.	100	12" O.C.	48" O.C.	100	12" O.C.	48" O.C.	100	12" O.C.	48" O.C.	100	12" O.C.	48" O.C.	100	12" O.C.	48" O.C.	100	12" O.C.	48" O.C.	100	12" O.C.	48" O.C.
	30	100	15" O.C.	48" O.C.	100	15" O.C.	48" O.C.	100	15" O.C.	48" O.C.	100	15" O.C.	48" O.C.	100	15" O.C.	48" O.C.	100	15" O.C.	48" O.C.	100	15" O.C.	48" O.C.	100	15" O.C.	48" O.C.
	36	100	18" O.C.	48" O.C.	100	18" O.C.	48" O.C.	100	18" O.C.	48" O.C.	100	18" O.C.	48" O.C.	100	18" O.C.	48" O.C.	100	18" O.C.	48" O.C.	100	18" O.C.	48" O.C.	100	18" O.C.	48" O.C.
	42	100	21" O.C.	48" O.C.	100	21" O.C.	48" O.C.	100	21" O.C.	48" O.C.	100	21" O.C.	48" O.C.	100	21" O.C.	48" O.C.	100	21" O.C.	48" O.C.	100	21" O.C.	48" O.C.	100	21" O.C.	48" O.C.
	48	97	24" O.C.	48" O.C.	100	24" O.C.	48" O.C.	100	24" O.C.	48" O.C.	100	24" O.C.	48" O.C.	100	24" O.C.	48" O.C.	100	24" O.C.	48" O.C.	100	24" O.C.	48" O.C.	100	24" O.C.	48" O.C.
	54	90	27" O.C.	48" O.C.	100	27" O.C.	48" O.C.	100	27" O.C.	48" O.C.	100	27" O.C.	48" O.C.	100	27" O.C.	48" O.C.	100	27" O.C.	48" O.C.	100	27" O.C.	48" O.C.	100	27" O.C.	48" O.C.
108	60	42	30" O.C.	48" O.C.	85	30" O.C.	48" O.C.	100	30" O.C.	32" O.C.	100	30" O.C.	32" O.C.	100	30" O.C.	32" O.C.	100	30" O.C.	32" O.C.	100	30" O.C.	32" O.C.	100	30" O.C.	32" O.C.
	66	40	33" O.C.	48" O.C.	81	33" O.C.	48" O.C.	100	33" O.C.	32" O.C.	100	33" O.C.	32" O.C.	100	33" O.C.	32" O.C.	100	33" O.C.	32" O.C.	100	33" O.C.	32" O.C.	100	33" O.C.	32" O.C.
	72	39	36" O.C.	48" O.C.	78	36" O.C.	48" O.C.	100	36" O.C.	32" O.C.	100	36" O.C.	32" O.C.	100	36" O.C.	32" O.C.	100	36" O.C.	32" O.C.	100	36" O.C.	32" O.C.	100	36" O.C.	32" O.C.
	78	38	39" O.C.	48" O.C.	76	39" O.C.	48" O.C.	100	39" O.C.	32" O.C.	100	39" O.C.	32" O.C.	100	39" O.C.	32" O.C.	100	39" O.C.	32" O.C.	100	39" O.C.	32" O.C.	100	39" O.C.	32" O.C.
	24	100	12" O.C.	54" O.C.	100	12" O.C.	54" O.C.	100	12" O.C.	54" O.C.	100	12" O.C.	54" O.C.	100	12" O.C.	54" O.C.	100	12" O.C.	54" O.C.	100	12" O.C.	54" O.C.	100	12" O.C.	54" O.C.
	30	100	15" O.C.	54" O.C.	100	15" O.C.	54" O.C.	100	15" O.C.	54" O.C.	100	15" O.C.	54" O.C.	100	15" O.C.	54" O.C.	100	15" O.C.	54" O.C.	100	15" O.C.	54" O.C.	100	15" O.C.	54" O.C.
	36	100	18" O.C.	54" O.C.	100	18" O.C.	54" O.C.	100	18" O.C.	54" O.C.	100	18" O.C.	54" O.C.	100	18" O.C.	54" O.C.	100	18" O.C.	54" O.C.	100	18" O.C.	54" O.C.	100	18" O.C.	54" O.C.
	42	92	21" O.C.	54" O.C.	100	21" O.C.	54" O.C.	100	21" O.C.	54" O.C.	100	21" O.C.	54" O.C.	100	21" O.C.	54" O.C.	100	21" O.C.	54" O.C.	100	21" O.C.	54" O.C.	100	21" O.C.	54" O.C.
120	48	83	24" O.C.	54" O.C.	100	24" O.C.	54" O.C.	100	24" O.C.	54" O.C.	100	24" O.C.	54" O.C.	100	24" O.C.	54" O.C.	100	24" O.C.	54" O.C.	100	24" O.C.	54" O.C.	100	24" O.C.	54" O.C.
	54	77	27" O.C.	54" O.C.	100	27" O.C.	54" O.C.	100	27" O.C.	54" O.C.	100	27" O.C.	54" O.C.	100	27" O.C.	54" O.C.	100	27" O.C.	54" O.C.	100	27" O.C.	54" O.C.	100	27" O.C.	54" O.C.
	60	36	30" O.C.	54" O.C.	72	30" O.C.	54" O.C.	100	30" O.C.	36" O.C.	100	30" O.C.	36" O.C.	100	30" O.C.	36" O.C.	100	30" O.C.	36" O.C.	100	30" O.C.	36" O.C.	100	30" O.C.	36" O.C.
	66	34	33" O.C.	54" O.C.	68	33" O.C.	54" O.C.	100	33" O.C.	36" O.C.	100	33" O.C.	36" O.C.	100	33" O.C.	36" O.C.	100	33" O.C.	36" O.C.	100	33" O.C.	36" O.C.	100	33" O.C.	36" O.C.
	72	32	36" O.C.	54" O.C.	65	36" O.C.	54" O.C.	97	36" O.C.	36" O.C.	100	36" O.C.	27" O.C.	100	36" O.C.	27" O.C.	100	36" O.C.	27" O.C.	100	36" O.C.	27" O.C.	100	36" O.C.	27" O.C.
	78	31	39" O.C.	54" O.C.	62	39" O.C.	54" O.C.	94	39" O.C.	36" O.C.	100	39" O.C.	27" O.C.	100	39" O.C.	27" O.C.	100	39" O.C.	27" O.C.	100	39" O.C.	27" O.C.	100	39" O.C.	27" O.C.
	24	100	12" O.C.	60" O.C.	100	12" O.C.	60" O.C.	100	12" O.C.	60" O.C.	100	12" O.C.	60" O.C.	100	12" O.C.	60" O.C.	100	12" O.C.	60" O.C.	100	12" O.C.	60" O.C.	100	12" O.C.	60" O.C.
	30	100	15" O.C.	60" O.C.	100	15" O.C.	60" O.C.	100	15" O.C.	60" O.C.	100	15" O.C.	60" O.C.	100	15" O.C.	60" O.C.	100	15" O.C.	60" O.C.	100	15" O.C.	60" O.C.	100	15" O.C.	60" O.C.
120	36	92	18" O.C.	60" O.C.	100	18" O.C.	60" O.C.	100	18" O.C.	60" O.C.	100	18" O.C.	60" O.C.	100	18" O.C.	60" O.C.	100	18" O.C.	60" O.C.	100	18" O.C.	60" O.C.	100	18" O.C.	60" O.C.
	42	81	21" O.C.	60" O.C.	100	21" O.C.	60" O.C.	100	21" O.C.	60" O.C.	100	21" O.C.	60" O.C.	100	21" O.C.	60" O.C.	100	21" O.C.	60" O.C.	100	21" O.C.	60" O.C.	100	21" O.C.	60" O.C.
	48	73	24" O.C.	60" O.C.	100	24" O.C.	60" O.C.	100	24" O.C.	60" O.C.	100	24" O.C.	60" O.C.	100	24" O.C.	60" O.C.	100	24" O.C.	60" O.C.	100	24" O.C.	60" O.C.	100	24" O.C.	60" O.C.
	54	67	27" O.C.	60" O.C.	100	27" O.C.	60" O.C.	100	27" O.C.	60" O.C.	100	27" O.C.	60" O.C.	100	27" O.C.	60" O.C.	100	27" O.C.	60" O.C.	100	27" O.C.	60" O.C.	100	27" O.C.	60" O.C.
	60	31	30" O.C.	60" O.C.	62	30" O.C.	60" O.C.	93	30" O.C.	40" O.C.	100	30" O.C.	30" O.C.	100	30" O.C.	30" O.C.	100	30" O.C.	30" O.C.	100	30" O.C.	30" O.C.	100	30" O.C.	30" O.C.
	66	29	33" O.C.	60" O.C.	58	33" O.C.	60" O.C.	88	33" O.C.	40" O.C.	100	33" O.C.	30" O.C.	100	33" O.C.	30" O.C.	100	33" O.C.	30" O.C.	100	33" O.C.	30" O.C.	100	33" O.C.	30" O.C.
	72	27	36" O.C.	60" O.C.	55	36" O.C.	60" O.C.	83	36" O.C.	40" O.C.	100	36" O.C.	30" O.C.	100	36" O.C.	30" O.C.	100	36" O.C.	30" O.C.	100	36" O.C.	30" O.C.	100	36" O.C.	30" O.C.
	78	26	39" O.C.	60" O.C.	53	39" O.C.	60" O.C.	80	39" O.C.	40" O.C.	100	39" O.C.	30" O.C.	100	39" O.C.	30" O.C.	100	39" O.C.	30" O.C.	100	39" O.C.	30" O.C.	100	39" O.C.	30" O.C.

ENGINEERING EXPRESS
CORPORATE OFFICE:
160 SW 12th AVE, SUITE 106
DEERFIELD BEACH, FL 33442
(954) 354-0660 | (866) 396-9999
TEAM@ENGINEERINGEXPRESS.COM
ENGINEERINGEXPRESS.COM

CRAWFORD TRACEY CORPORATION
3301 S.W. 13th DRIVE
DEERFIELD BEACH, FL, 33442-8101
Phn. (954) 698-6888
PRO-TECH 4-SSG ALUMINUM CURTAINWALL SYSTEM
FLORIDA STATE APPROVAL

REMARKS	DATE	CHKD	DATE	CHKD
FBC 2020 UPDATE	10/19/20	JEM	AJP	

COPYRIGHT ENGINEERING EXPRESS®
20-32267
SCALE: NTS UNLESS NOTED
30

THIS DOCUMENT IS THE PROPERTY OF ENGINEERING EXPRESS, AND SHALL NOT BE REPRODUCED IN WHOLE OR PART WITHOUT WRITTEN CONSENT OF ENGINEERING EXPRESS. ALTERATIONS, ADDITIONS, OR OTHER MARKINGS TO THIS DOCUMENT ARE NOT PERMITTED AND INVALIDATE OUR CERTIFICATION.

**MAXIMUM ALLOWABLE STRESS DESIGN PRESSURE RATING FOR
HEAD, SILL AND JAMB CONNECTIONS-ANCHOR TYPE C "MAX SHIM = 1/4"**

FRANK BENNARDO, P.E.
PE# 0046549 CA 9885



FL#29520.4

FRAME HEIGHT (H)	TRIBUTARY (W)	TOTAL NUMBER OF ANCHORS AT THE CLUSTER-ANCHOR TYPE C																							
		2			4			6			8			10			12			16					
		MAX PRESSURE (PSF)	HEAD/SILL MAX ANCHOR SPACING (IN)	JAMBS MAX ANCHOR SPACING (IN)	MAX PRESSURE (PSF)	HEAD/SILL MAX ANCHOR SPACING (IN)	JAMBS MAX ANCHOR SPACING (IN)	MAX PRESSURE (PSF)	HEAD/SILL MAX ANCHOR SPACING (IN)	JAMBS MAX ANCHOR SPACING (IN)	MAX PRESSURE (PSF)	HEAD/SILL MAX ANCHOR SPACING (IN)	JAMBS MAX ANCHOR SPACING (IN)	MAX PRESSURE (PSF)	HEAD/SILL MAX ANCHOR SPACING (IN)	JAMBS MAX ANCHOR SPACING (IN)	MAX PRESSURE (PSF)	HEAD/SILL MAX ANCHOR SPACING (IN)	JAMBS MAX ANCHOR SPACING (IN)	MAX PRESSURE (PSF)	HEAD/SILL MAX ANCHOR SPACING (IN)	JAMBS MAX ANCHOR SPACING (IN)			
36	24	100	12" O.C.	18" O.C.	100	12" O.C.	18" O.C.	100	12" O.C.	18" O.C.	100	12" O.C.	18" O.C.	100	12" O.C.	18" O.C.	100	12" O.C.	18" O.C.	100	12" O.C.	18" O.C.			
	30	100	15" O.C.	18" O.C.	100	15" O.C.	18" O.C.	100	15" O.C.	18" O.C.	100	15" O.C.	18" O.C.	100	15" O.C.	18" O.C.	100	15" O.C.	18" O.C.	100	15" O.C.	18" O.C.			
	36	100	18" O.C.	18" O.C.	100	18" O.C.	18" O.C.	100	18" O.C.	18" O.C.	100	18" O.C.	18" O.C.	100	18" O.C.	18" O.C.	100	18" O.C.	18" O.C.	100	18" O.C.	18" O.C.			
	42	100	14" O.C.	18" O.C.	100	14" O.C.	18" O.C.	100	14" O.C.	18" O.C.	100	14" O.C.	18" O.C.	100	14" O.C.	18" O.C.	100	14" O.C.	18" O.C.	100	14" O.C.	18" O.C.			
	48	100	16" O.C.	18" O.C.	100	16" O.C.	18" O.C.	100	16" O.C.	18" O.C.	100	16" O.C.	18" O.C.	100	16" O.C.	18" O.C.	100	16" O.C.	18" O.C.	100	16" O.C.	18" O.C.			
	54	100	14" O.C.	18" O.C.	100	14" O.C.	18" O.C.	100	14" O.C.	18" O.C.	100	14" O.C.	18" O.C.	100	14" O.C.	18" O.C.	100	14" O.C.	18" O.C.	100	14" O.C.	18" O.C.			
	60	60	20" O.C.	18" O.C.	100	15" O.C.	18" O.C.	100	15" O.C.	18" O.C.	100	15" O.C.	18" O.C.	100	15" O.C.	18" O.C.	100	15" O.C.	18" O.C.	100	15" O.C.	18" O.C.			
	66	60	22" O.C.	18" O.C.	100	13" O.C.	18" O.C.	100	13" O.C.	18" O.C.	100	13" O.C.	18" O.C.	100	13" O.C.	18" O.C.	100	13" O.C.	18" O.C.	100	13" O.C.	18" O.C.			
72	60	24" O.C.	18" O.C.	100	14" O.C.	18" O.C.	100	14" O.C.	18" O.C.	100	14" O.C.	18" O.C.	100	14" O.C.	18" O.C.	100	14" O.C.	18" O.C.	100	14" O.C.	18" O.C.				
78	60	20" O.C.	18" O.C.	100	13" O.C.	18" O.C.	100	13" O.C.	18" O.C.	100	13" O.C.	18" O.C.	100	13" O.C.	18" O.C.	100	13" O.C.	18" O.C.	100	13" O.C.	18" O.C.				
48	24	91	12" O.C.	24" O.C.	100	12" O.C.	24" O.C.	100	12" O.C.	24" O.C.	100	12" O.C.	24" O.C.	100	12" O.C.	24" O.C.	100	12" O.C.	24" O.C.	100	12" O.C.	24" O.C.			
	30	79	15" O.C.	24" O.C.	100	15" O.C.	24" O.C.	100	15" O.C.	24" O.C.	100	15" O.C.	24" O.C.	100	15" O.C.	24" O.C.	100	15" O.C.	24" O.C.	100	15" O.C.	24" O.C.			
	36	73	18" O.C.	24" O.C.	100	18" O.C.	24" O.C.	100	18" O.C.	24" O.C.	100	18" O.C.	24" O.C.	100	18" O.C.	24" O.C.	100	18" O.C.	24" O.C.	100	18" O.C.	24" O.C.			
	42	69	21" O.C.	24" O.C.	100	14" O.C.	24" O.C.	100	14" O.C.	24" O.C.	100	14" O.C.	24" O.C.	100	14" O.C.	24" O.C.	100	14" O.C.	24" O.C.	100	14" O.C.	24" O.C.			
	48	68	24" O.C.	24" O.C.	100	16" O.C.	24" O.C.	100	16" O.C.	24" O.C.	100	16" O.C.	24" O.C.	100	16" O.C.	24" O.C.	100	16" O.C.	24" O.C.	100	16" O.C.	24" O.C.			
	54	68	18" O.C.	24" O.C.	100	14" O.C.	24" O.C.	100	14" O.C.	24" O.C.	100	14" O.C.	24" O.C.	100	14" O.C.	24" O.C.	100	14" O.C.	24" O.C.	100	14" O.C.	24" O.C.			
	60	34	30" O.C.	24" O.C.	68	20" O.C.	24" O.C.	100	12" O.C.	16" O.C.	100	12" O.C.	16" O.C.	100	12" O.C.	16" O.C.	100	12" O.C.	16" O.C.	100	12" O.C.	16" O.C.			
	66	34	33" O.C.	24" O.C.	68	17" O.C.	24" O.C.	100	11" O.C.	16" O.C.	100	11" O.C.	16" O.C.	100	11" O.C.	16" O.C.	100	11" O.C.	16" O.C.	100	11" O.C.	16" O.C.			
72	34	36" O.C.	24" O.C.	68	18" O.C.	24" O.C.	100	12" O.C.	16" O.C.	100	12" O.C.	16" O.C.	100	12" O.C.	16" O.C.	100	12" O.C.	16" O.C.	100	12" O.C.	16" O.C.				
78	34	26" O.C.	24" O.C.	68	16" O.C.	24" O.C.	100	11" O.C.	16" O.C.	100	11" O.C.	16" O.C.	100	11" O.C.	16" O.C.	100	11" O.C.	16" O.C.	100	11" O.C.	16" O.C.				
60	24	68	12" O.C.	30" O.C.	100	12" O.C.	30" O.C.	100	12" O.C.	30" O.C.	100	12" O.C.	30" O.C.	100	12" O.C.	30" O.C.	100	12" O.C.	30" O.C.	100	12" O.C.	30" O.C.			
	30	58	15" O.C.	30" O.C.	100	15" O.C.	30" O.C.	100	15" O.C.	30" O.C.	100	15" O.C.	30" O.C.	100	15" O.C.	30" O.C.	100	15" O.C.	30" O.C.	100	15" O.C.	30" O.C.			
	36	52	18" O.C.	30" O.C.	100	18" O.C.	30" O.C.	100	18" O.C.	30" O.C.	100	18" O.C.	30" O.C.	100	18" O.C.	30" O.C.	100	18" O.C.	30" O.C.	100	18" O.C.	30" O.C.			
	42	48	21" O.C.	30" O.C.	96	14" O.C.	30" O.C.	100	14" O.C.	30" O.C.	100	14" O.C.	30" O.C.	100	14" O.C.	30" O.C.	100	14" O.C.	30" O.C.	100	14" O.C.	30" O.C.			
	48	45	24" O.C.	30" O.C.	91	16" O.C.	30" O.C.	100	16" O.C.	30" O.C.	100	16" O.C.	30" O.C.	100	16" O.C.	30" O.C.	100	16" O.C.	30" O.C.	100	16" O.C.	30" O.C.			
	54	44	27" O.C.	30" O.C.	88	14" O.C.	30" O.C.	100	14" O.C.	30" O.C.	100	14" O.C.	30" O.C.	100	14" O.C.	30" O.C.	100	14" O.C.	30" O.C.	100	14" O.C.	30" O.C.			
	60	21	30" O.C.	30" O.C.	43	30" O.C.	30" O.C.	65	20" O.C.	20" O.C.	87	15" O.C.	15" O.C.	100	12" O.C.	12" O.C.	100	12" O.C.	12" O.C.	100	12" O.C.	12" O.C.			
	66	21	33" O.C.	30" O.C.	43	22" O.C.	30" O.C.	65	17" O.C.	20" O.C.	87	13" O.C.	15" O.C.	100	11" O.C.	12" O.C.	100	11" O.C.	12" O.C.	100	11" O.C.	12" O.C.			
72	21	36" O.C.	30" O.C.	43	24" O.C.	30" O.C.	65	14" O.C.	20" O.C.	87	12" O.C.	15" O.C.	100	10" O.C.	12" O.C.	100	10" O.C.	12" O.C.	100	10" O.C.	12" O.C.				
78	21	39" O.C.	30" O.C.	43	20" O.C.	30" O.C.	65	16" O.C.	20" O.C.	87	11" O.C.	15" O.C.	100	10" O.C.	12" O.C.	100	10" O.C.	12" O.C.	100	10" O.C.	12" O.C.				
72	24	54	12" O.C.	36" O.C.	100	12" O.C.	36" O.C.	100	12" O.C.	36" O.C.	100	12" O.C.	36" O.C.	100	12" O.C.	36" O.C.	100	12" O.C.	36" O.C.	100	12" O.C.	36" O.C.			
	30	46	15" O.C.	36" O.C.	92	15" O.C.	36" O.C.	100	15" O.C.	36" O.C.	100	15" O.C.	36" O.C.	100	15" O.C.	36" O.C.	100	15" O.C.	36" O.C.	100	15" O.C.	36" O.C.			
	36	40	18" O.C.	36" O.C.	81	18" O.C.	36" O.C.	100	18" O.C.	36" O.C.	100	18" O.C.	36" O.C.	100	18" O.C.	36" O.C.	100	18" O.C.	36" O.C.	100	18" O.C.	36" O.C.			
	42	36	21" O.C.	36" O.C.	73	21" O.C.	36" O.C.	100	14" O.C.	36" O.C.	100	14" O.C.	36" O.C.	100	14" O.C.	36" O.C.	100	14" O.C.	36" O.C.	100	14" O.C.	36" O.C.			
	48	34	24" O.C.	36" O.C.	68	24" O.C.	36" O.C.	100	16" O.C.	36" O.C.	100	16" O.C.	36" O.C.	100	16" O.C.	36" O.C.	100	16" O.C.	36" O.C.	100	16" O.C.	36" O.C.			
	54	32	27" O.C.	36" O.C.	64	18" O.C.	36" O.C.	97	14" O.C.	36" O.C.	100	14" O.C.	36" O.C.	100	14" O.C.	36" O.C.	100	14" O.C.	36" O.C.	100	14" O.C.	36" O.C.			
	60	15	30" O.C.	36" O.C.	31	30" O.C.	36" O.C.	46	20" O.C.	24" O.C.	62	20" O.C.	18" O.C.	78	15" O.C.	14" O.C.	93	12" O.C.	12" O.C.	100	12" O.C.	10" O.C.			
	66	15	33" O.C.	36" O.C.	30	33" O.C.	36" O.C.	45	22" O.C.	24" O.C.	61	17" O.C.	18" O.C.	76	13" O.C.	14" O.C.	91	11" O.C.	12" O.C.	100	11" O.C.	10" O.C.			
72	15	36" O.C.	36" O.C.	30	36" O.C.	36" O.C.	45	24" O.C.	24" O.C.	60	18" O.C.	18" O.C.	76	14" O.C.	14" O.C.	91	12" O.C.	12" O.C.	100	10" O.C.	10" O.C.				
78	15	39" O.C.	36" O.C.	30	26" O.C.	36" O.C.	45	20" O.C.	24" O.C.	60	16" O.C.	18" O.C.	76	13" O.C.	14" O.C.	91	11" O.C.	12" O.C.	100	10" O.C.	10" O.C.				

ENGINEERING EXPRESS
CORPORATE OFFICE:
160 SW 12th AVE, SUITE 106
DEERFIELD BEACH, FL 33442
(954) 354-0660 | (866) 396-9999
TEAM@ENGINEERINGEXPRESS.COM
ENGINEERINGEXPRESS.COM

CRAWFORD TRACEY CORPORATION
3301 S.W. 13th DRIVE
DEERFIELD BEACH, FL, 33442-8101
Phn. (954) 698-6888
PRO-TECH 455G ALUMINUM CURTAINWALL SYSTEM
FLORIDA STATE APPROVAL

REMARKS	DATE	DRAWN	CHKD
FBC 2020 UPDATE	10/19/20	JEM	AJP

THIS DOCUMENT IS THE PROPERTY OF ENGINEERING EXPRESS, AND SHALL NOT BE REPRODUCED IN WHOLE OR PART WITHOUT WRITTEN CONSENT OF ENGINEERING EXPRESS. ALTERATIONS, ADDITIONS, OR OTHER MARKINGS TO THIS DOCUMENT ARE NOT PERMITTED AND INVALIDATE OUR CERTIFICATION.

**MAXIMUM ALLOWABLE STRESS DESIGN PRESSURE RATING FOR
HEAD, SILL AND JAMB CONNECTIONS-ANCHOR TYPE C "MAX SHIM = 1/4"**

FRANK BERNARDO, P.E.
PE# 0046549 CA 9885



FL#29520.4

FRAME HEIGHT (H)	TRIBUTARY (W)	TOTAL NUMBER OF ANCHORS AT THE CLUSTER-ANCHOR TYPE C																							
		2			4			6			8			10			12			16					
		MAX PRESSURE (PSF)	HEAD/SILL MAX ANCHOR SPACING (IN)	JAMBS MAX ANCHOR SPACING (IN)	MAX PRESSURE (PSF)	HEAD/SILL MAX ANCHOR SPACING (IN)	JAMBS MAX ANCHOR SPACING (IN)	MAX PRESSURE (PSF)	HEAD/SILL MAX ANCHOR SPACING (IN)	JAMBS MAX ANCHOR SPACING (IN)	MAX PRESSURE (PSF)	HEAD/SILL MAX ANCHOR SPACING (IN)	JAMBS MAX ANCHOR SPACING (IN)	MAX PRESSURE (PSF)	HEAD/SILL MAX ANCHOR SPACING (IN)	JAMBS MAX ANCHOR SPACING (IN)	MAX PRESSURE (PSF)	HEAD/SILL MAX ANCHOR SPACING (IN)	JAMBS MAX ANCHOR SPACING (IN)	MAX PRESSURE (PSF)	HEAD/SILL MAX ANCHOR SPACING (IN)	JAMBS MAX ANCHOR SPACING (IN)			
84	24	45	12" O.C.	42" O.C.	91	12" O.C.	42" O.C.	100	12" O.C.	42" O.C.	100	12" O.C.	42" O.C.	100	12" O.C.	42" O.C.	100	12" O.C.	42" O.C.	100	12" O.C.	42" O.C.			
	30	38	15" O.C.	42" O.C.	76	15" O.C.	42" O.C.	100	15" O.C.	42" O.C.	100	15" O.C.	42" O.C.	100	15" O.C.	42" O.C.	100	15" O.C.	42" O.C.	100	15" O.C.	42" O.C.			
	36	33	18" O.C.	42" O.C.	66	18" O.C.	42" O.C.	99	18" O.C.	42" O.C.	100	18" O.C.	42" O.C.	100	18" O.C.	42" O.C.	100	18" O.C.	42" O.C.	100	18" O.C.	42" O.C.			
	42	29	21" O.C.	42" O.C.	59	21" O.C.	42" O.C.	89	21" O.C.	42" O.C.	100	21" O.C.	42" O.C.	100	21" O.C.	42" O.C.	100	21" O.C.	42" O.C.	100	21" O.C.	42" O.C.			
	48	27	24" O.C.	42" O.C.	54	24" O.C.	42" O.C.	82	24" O.C.	42" O.C.	100	24" O.C.	42" O.C.	100	24" O.C.	42" O.C.	100	24" O.C.	42" O.C.	100	24" O.C.	42" O.C.			
	54	25	27" O.C.	42" O.C.	51	27" O.C.	42" O.C.	76	27" O.C.	42" O.C.	100	27" O.C.	42" O.C.	100	27" O.C.	42" O.C.	100	27" O.C.	42" O.C.	100	27" O.C.	42" O.C.			
	60	12	30" O.C.	42" O.C.	24	30" O.C.	42" O.C.	36	30" O.C.	28" O.C.	48	20" O.C.	21" O.C.	60	20" O.C.	17" O.C.	73	15" O.C.	14" O.C.	97	12" O.C.	11" O.C.			
	66	11	33" O.C.	42" O.C.	23	33" O.C.	42" O.C.	35	33" O.C.	28" O.C.	46	22" O.C.	21" O.C.	58	17" O.C.	17" O.C.	70	17" O.C.	14" O.C.	93	11" O.C.	11" O.C.			
	72	11	36" O.C.	42" O.C.	22	36" O.C.	42" O.C.	34	36" O.C.	28" O.C.	45	24" O.C.	21" O.C.	57	18" O.C.	17" O.C.	68	14" O.C.	14" O.C.	91	12" O.C.	11" O.C.			
78	11	39" O.C.	42" O.C.	22	39" O.C.	42" O.C.	33	39" O.C.	28" O.C.	44	20" O.C.	21" O.C.	56	16" O.C.	17" O.C.	67	13" O.C.	14" O.C.	89	11" O.C.	11" O.C.				
96	24	39	12" O.C.	48" O.C.	78	12" O.C.	48" O.C.	100	12" O.C.	48" O.C.	100	12" O.C.	48" O.C.	100	12" O.C.	48" O.C.	100	12" O.C.	48" O.C.	100	12" O.C.	48" O.C.			
	30	32	15" O.C.	48" O.C.	64	15" O.C.	48" O.C.	97	15" O.C.	48" O.C.	100	15" O.C.	48" O.C.	100	15" O.C.	48" O.C.	100	15" O.C.	48" O.C.	100	15" O.C.	48" O.C.			
	36	28	18" O.C.	48" O.C.	56	18" O.C.	48" O.C.	84	18" O.C.	48" O.C.	100	18" O.C.	48" O.C.	100	18" O.C.	48" O.C.	100	18" O.C.	48" O.C.	100	18" O.C.	48" O.C.			
	42	25	21" O.C.	48" O.C.	50	21" O.C.	48" O.C.	75	21" O.C.	48" O.C.	100	21" O.C.	48" O.C.	100	21" O.C.	48" O.C.	100	21" O.C.	48" O.C.	100	21" O.C.	48" O.C.			
	48	22	24" O.C.	48" O.C.	45	24" O.C.	48" O.C.	68	24" O.C.	48" O.C.	91	16" O.C.	48" O.C.	100	16" O.C.	32" O.C.	100	16" O.C.	32" O.C.	100	16" O.C.	32" O.C.			
	54	21	27" O.C.	48" O.C.	42	27" O.C.	48" O.C.	63	27" O.C.	48" O.C.	84	14" O.C.	48" O.C.	100	14" O.C.	32" O.C.	100	14" O.C.	32" O.C.	100	14" O.C.	32" O.C.			
	60	9	30" O.C.	48" O.C.	19	30" O.C.	48" O.C.	29	30" O.C.	32" O.C.	39	30" O.C.	24" O.C.	49	20" O.C.	19" O.C.	59	20" O.C.	16" O.C.	79	15" O.C.	12" O.C.			
	66	9	33" O.C.	48" O.C.	18	33" O.C.	48" O.C.	28	33" O.C.	32" O.C.	37	22" O.C.	24" O.C.	47	22" O.C.	19" O.C.	56	17" O.C.	16" O.C.	75	13" O.C.	12" O.C.			
	72	9	36" O.C.	48" O.C.	18	36" O.C.	48" O.C.	27	36" O.C.	32" O.C.	36	24" O.C.	24" O.C.	45	24" O.C.	19" O.C.	54	18" O.C.	16" O.C.	73	14" O.C.	12" O.C.			
78	8	39" O.C.	48" O.C.	17	39" O.C.	48" O.C.	26	39" O.C.	32" O.C.	35	26" O.C.	24" O.C.	44	20" O.C.	19" O.C.	53	16" O.C.	16" O.C.	70	13" O.C.	12" O.C.				
108	24	34	12" O.C.	54" O.C.	68	12" O.C.	54" O.C.	100	12" O.C.	54" O.C.	100	12" O.C.	54" O.C.	100	12" O.C.	54" O.C.	100	12" O.C.	54" O.C.	100	12" O.C.	54" O.C.			
	30	28	15" O.C.	54" O.C.	56	15" O.C.	54" O.C.	84	15" O.C.	54" O.C.	100	15" O.C.	54" O.C.	100	15" O.C.	54" O.C.	100	15" O.C.	54" O.C.	100	15" O.C.	54" O.C.			
	36	24	18" O.C.	54" O.C.	48	18" O.C.	54" O.C.	73	18" O.C.	54" O.C.	97	18" O.C.	54" O.C.	100	18" O.C.	36" O.C.	100	18" O.C.	36" O.C.	100	18" O.C.	36" O.C.			
	42	21	21" O.C.	54" O.C.	43	21" O.C.	54" O.C.	64	21" O.C.	54" O.C.	86	21" O.C.	54" O.C.	100	14" O.C.	36" O.C.	100	14" O.C.	36" O.C.	100	14" O.C.	36" O.C.			
	48	19	24" O.C.	54" O.C.	39	24" O.C.	54" O.C.	58	24" O.C.	54" O.C.	78	16" O.C.	54" O.C.	97	16" O.C.	36" O.C.	100	16" O.C.	36" O.C.	100	16" O.C.	36" O.C.			
	54	18	27" O.C.	54" O.C.	36	27" O.C.	54" O.C.	54	27" O.C.	54" O.C.	72	18" O.C.	54" O.C.	90	14" O.C.	36" O.C.	100	14" O.C.	36" O.C.	100	14" O.C.	36" O.C.			
	60	8	30" O.C.	54" O.C.	16	30" O.C.	54" O.C.	25	30" O.C.	36" O.C.	33	30" O.C.	27" O.C.	42	30" O.C.	22" O.C.	50	20" O.C.	18" O.C.	67	15" O.C.	14" O.C.			
	66	7	33" O.C.	54" O.C.	15	33" O.C.	54" O.C.	23	33" O.C.	36" O.C.	31	33" O.C.	27" O.C.	39	22" O.C.	22" O.C.	47	22" O.C.	18" O.C.	63	17" O.C.	14" O.C.			
	72	7	36" O.C.	54" O.C.	15	36" O.C.	54" O.C.	22	36" O.C.	36" O.C.	30	36" O.C.	27" O.C.	38	24" O.C.	22" O.C.	45	24" O.C.	18" O.C.	60	18" O.C.	14" O.C.			
78	7	39" O.C.	54" O.C.	14	39" O.C.	54" O.C.	21	39" O.C.	36" O.C.	29	26" O.C.	27" O.C.	36	26" O.C.	22" O.C.	43	20" O.C.	18" O.C.	58	16" O.C.	14" O.C.				
120	24	30	12" O.C.	60" O.C.	60	12" O.C.	60" O.C.	91	12" O.C.	60" O.C.	100	12" O.C.	60" O.C.	100	12" O.C.	60" O.C.	100	12" O.C.	60" O.C.	100	12" O.C.	60" O.C.			
	30	25	15" O.C.	60" O.C.	50	15" O.C.	60" O.C.	75	15" O.C.	60" O.C.	100	15" O.C.	60" O.C.	100	15" O.C.	60" O.C.	100	15" O.C.	60" O.C.	100	15" O.C.	60" O.C.			
	36	21	18" O.C.	60" O.C.	42	18" O.C.	60" O.C.	64	18" O.C.	60" O.C.	85	18" O.C.	60" O.C.	100	18" O.C.	40" O.C.	100	18" O.C.	40" O.C.	100	18" O.C.	40" O.C.			
	42	18	21" O.C.	60" O.C.	37	21" O.C.	60" O.C.	56	21" O.C.	60" O.C.	75	21" O.C.	60" O.C.	94	14" O.C.	40" O.C.	100	14" O.C.	40" O.C.	100	14" O.C.	40" O.C.			
	48	17	24" O.C.	60" O.C.	34	24" O.C.	60" O.C.	51	24" O.C.	60" O.C.	68	24" O.C.	60" O.C.	85	16" O.C.	40" O.C.	100	16" O.C.	40" O.C.	100	16" O.C.	40" O.C.			
	54	15	27" O.C.	60" O.C.	31	27" O.C.	60" O.C.	47	27" O.C.	60" O.C.	62	18" O.C.	60" O.C.	78	18" O.C.	40" O.C.	94	14" O.C.	40" O.C.	100	14" O.C.	30" O.C.			
	60	7	30" O.C.	60" O.C.	14	30" O.C.	60" O.C.	21	30" O.C.	40" O.C.	29	30" O.C.	30" O.C.	36	30" O.C.	24" O.C.	43	30" O.C.	20" O.C.	58	20" O.C.	15" O.C.			
	66	6	33" O.C.	60" O.C.	13	33" O.C.	60" O.C.	20	33" O.C.	40" O.C.	27	33" O.C.	30" O.C.	34	33" O.C.	24" O.C.	41	22" O.C.	20" O.C.	54	22" O.C.	15" O.C.			
	72	6	36" O.C.	60" O.C.	13	36" O.C.	60" O.C.	19	36" O.C.	40" O.C.	26	36" O.C.	30" O.C.	32	24" O.C.	24" O.C.	39	24" O.C.	20" O.C.	52	18" O.C.	15" O.C.			
78	6	39" O.C.	60" O.C.	12	39" O.C.	60" O.C.	18	39" O.C.	40" O.C.	24	39" O.C.	30" O.C.	31	26" O.C.	24" O.C.	37	26" O.C.	20" O.C.	49	20" O.C.	15" O.C.				

ENGINEERING EXPRESS
CORPORATE OFFICE:
160 SW 12th AVE, SUITE 106
DEERFIELD BEACH, FL 33442
(954) 354-0660 | (866) 396-9999
TEAM@ENGINEERINGEXPRESS.COM
ENGINEERINGEXPRESS.COM

CRAWFORD TRACEY CORPORATION
3301 S.W. 13th DRIVE
DEERFIELD BEACH, FL, 33442-8101
Phn. (954) 698-6888
PRO-TECH 455G ALUMINUM CURTAINWALL SYSTEM
FLORIDA STATE APPROVAL

REMARKS	DATE	CHKD	DATE
FBC 2020 UPDATE	10/19/20	JEM	AJP

THIS DOCUMENT IS THE PROPERTY OF ENGINEERING EXPRESS, AND SHALL NOT BE REPRODUCED IN WHOLE OR PART WITHOUT WRITTEN CONSENT OF ENGINEERING EXPRESS. ALTERATIONS, ADDITIONS, OR OTHER MARKINGS TO THIS DOCUMENT ARE NOT PERMITTED AND INVALIDATE OUR CERTIFICATION.

COPYRIGHT ENGINEERING EXPRESS®
20-32267
SCALE: NTS UNLESS NOTED
32

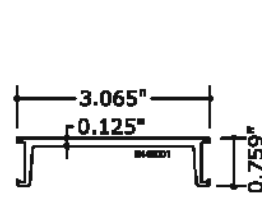

1 SUB-BUCK

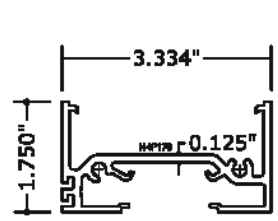

2 FRAME HEAD/SILL

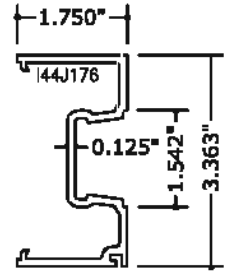

5 FRAME JAMB

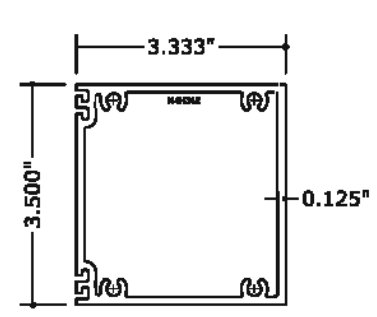

6 HORIZONTAL INTERMEDIATE

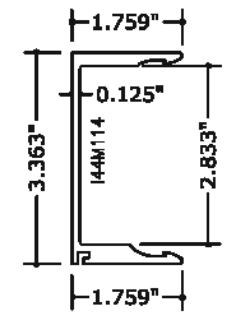

7 FEMALE JAMB / MULLION

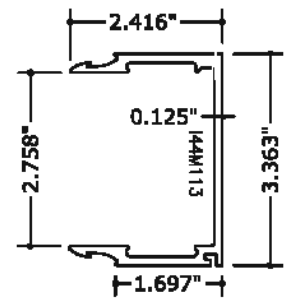

8 MALE JAMB / MULLION

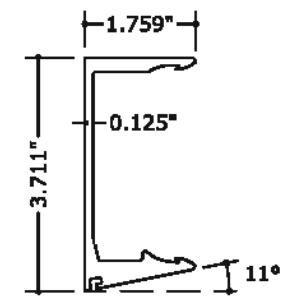

7A FEMALE JAMB / MULLION

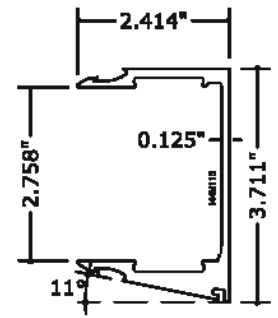

8A MALE JAMB / MULLION

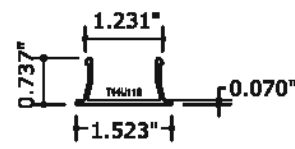

9 SNAP IN COVER

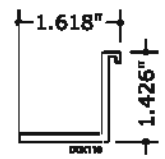

10 GLASS SUPPORT

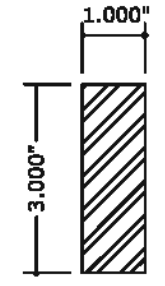

14 STEEL REINFORCEMENT BAR (FULL LENGTH)

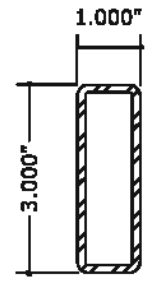

15 STEEL REINFORCEMENT TUBE (FULL LENGTH)



20 APPLIED TRIM CAP

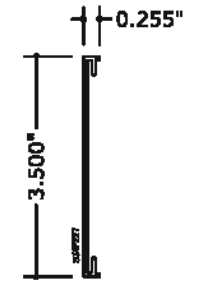

21 APPLIED TRIM CAP

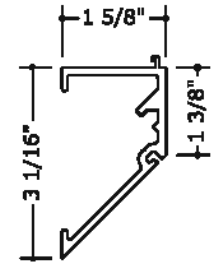

24 270° CORNER ADAPTOR



FL#29520.4

ENGINEERING EXPRESS
CORPORATE OFFICE:
160 SW 12th AVE, SUITE 106
DEERFIELD BEACH, FL 33442
(954) 354-0660 | (866) 396-9999
TEAM@ENGINEERINGEXPRESS.COM
ENGINEERINGEXPRESS.COM

CRAWFORD TRACEY CORPORATION
3301 S.W. 13th DRIVE
DEERFIELD BEACH, FL, 33442-8101
Phn. (954) 698-6888

PRO-TECH 455G ALUMINUM CURTAINWALL SYSTEM
FLORIDA STATE APPROVAL

REMARKS	DRWN	CHKD	DATE
FBC 2020 UPDATE	JEM	AJP	10/19/20

THIS DOCUMENT IS THE PROPERTY OF ENGINEERING EXPRESS, AND SHALL NOT BE REPRODUCED IN WHOLE OR PART, WITHOUT WRITTEN CONSENT OF ENGINEERING EXPRESS. ALTERATIONS, ADDITIONS, OR OTHER MARKINGS TO THIS DOCUMENT ARE NOT PERMITTED AND INVALIDATE OUR CERTIFICATION.

COPYRIGHT ENGINEERING EXPRESS®

20-32267

SCALE: NTS UNLESS NOTED

33



BILL OF MATERIALS

ITEM NO.	PART NUMBER	QUANTITY	DESCRIPTION	MATERIAL	MANF. / SUPPLIER / REMARKS
1	B44B001	AS REQD.	SUB-BUCK	6005A-T61	-----
2	I44P176	AS REQD.	FRAME HEAD / SILL	6063-T6	-----
5	I44J176	AS REQD.	FRAME JAMB	6063-T6	-----
6	I44H342	AS REQD.	HORIZONTAL	6063-T6	-----
7	I44M114	AS REQD.	FEMALE MULLION	6063-T6	-----
7A	I44M116	AS REQD.	ALT. FEMALE MULLION	6063-T6	-----
8	I44M113	AS REQD.	MALE MULLION	6063-T6	-----
8A	I44M115	AS REQD.	ALT. MALE MULLION	6063-T6	-----
9	T44U119	AS REQD.	SNAP-IN COVER	6063-T6	-----
10	170X116	AS REQD.	4" LONG SETTING PIECE (INSUL. LAM. GLASS)	6005A-T61	AT 1/4 POINTS
11	#2	AS REQD.	INTERIOR GLAZING GASKET	POLYPROPYLENE	-----
13	DOWSIL 983	-	GLAZING COMPOUND	SILICONE	-----
14	-	AS REQD.	STEEL BAR, FULL LENGTH	STEEL	1"x 3"
15	-	AS REQD.	REINFORCING TUBE, FULL LENGTH	STEEL	1"x 3"x 11 GA.
16	#14 X 1 1/4"	AS REQD.	FRAME ASSEMBLY SCREWS	ST. STEEL	P.H. SMS
17	-	AS REQD.	FILLER CHANNEL	ALUMINUM	13/16"x 1 1/2"x 13/16"x 1/8"
18	-	AS REQD.	FILLER CHANNEL	ALUMINUM	11/16"x 1 1/4"x 11/16"x 1/8"
19	#10 X 1"	AS REQD.	FILLER CHANNEL SCREWS	ST. STEEL	AT 14" O.C.
20	S15F227	AS REQD.	APPLIED TRIM CAP (OPTIONAL)	6063-T5	-----
21	S34F227	AS REQD.	APPLIED TRIM CAP (OPTIONAL)	6063-T6	-----
22	-	AS REQD.	DOUBLE SIDED GLAZING TAPE	FOAM	-----
23	-	AS REQD.	SETTING BLOCK AT 1/4 POINTS (1/16" OR 1/8" X 4")	SILICONE	DUROMETER 80 ± 5 SHORE A
24	I45C270	AS REQD.	270° CORNER ADAPTOR	6063-T6	-----

FL#29520.4

ENGINEERING EXPRESS
CORPORATE OFFICE:
160 SW 12th AVE, SUITE 106
DEERFIELD BEACH, FL 33442
(954) 354-0660 | (866) 396-9999
TEAM@ENGINEERINGEXPRESS.COM
ENGINEERINGEXPRESS.COM

CRAWFORD TRACEY CORPORATION
3301 S.W. 13th DRIVE
DEERFIELD BEACH, FL, 33442-8101
Phn. (954) 698-6888

PRO-TECH 455G ALUMINUM CURTAINWALL SYSTEM
FLORIDA STATE APPROVAL

REMARKS	DRWN	CHKD	DATE
FBC 2020 UPDATE	JEM	AJP	10/19/20

THIS DOCUMENT IS THE PROPERTY OF ENGINEERING EXPRESS, AND SHALL NOT BE REPRODUCED IN WHOLE OR PART, WITHOUT WRITTEN CONSENT OF ENGINEERING EXPRESS. ALTERATIONS, ADDITIONS, OR OTHER MARKINGS TO THIS DOCUMENT ARE NOT PERMITTED AND INVALIDATE OUR CERTIFICATION.

COPYRIGHT ENGINEERING EXPRESS®

20-32267

SCALE: NTS UNLESS NOTED

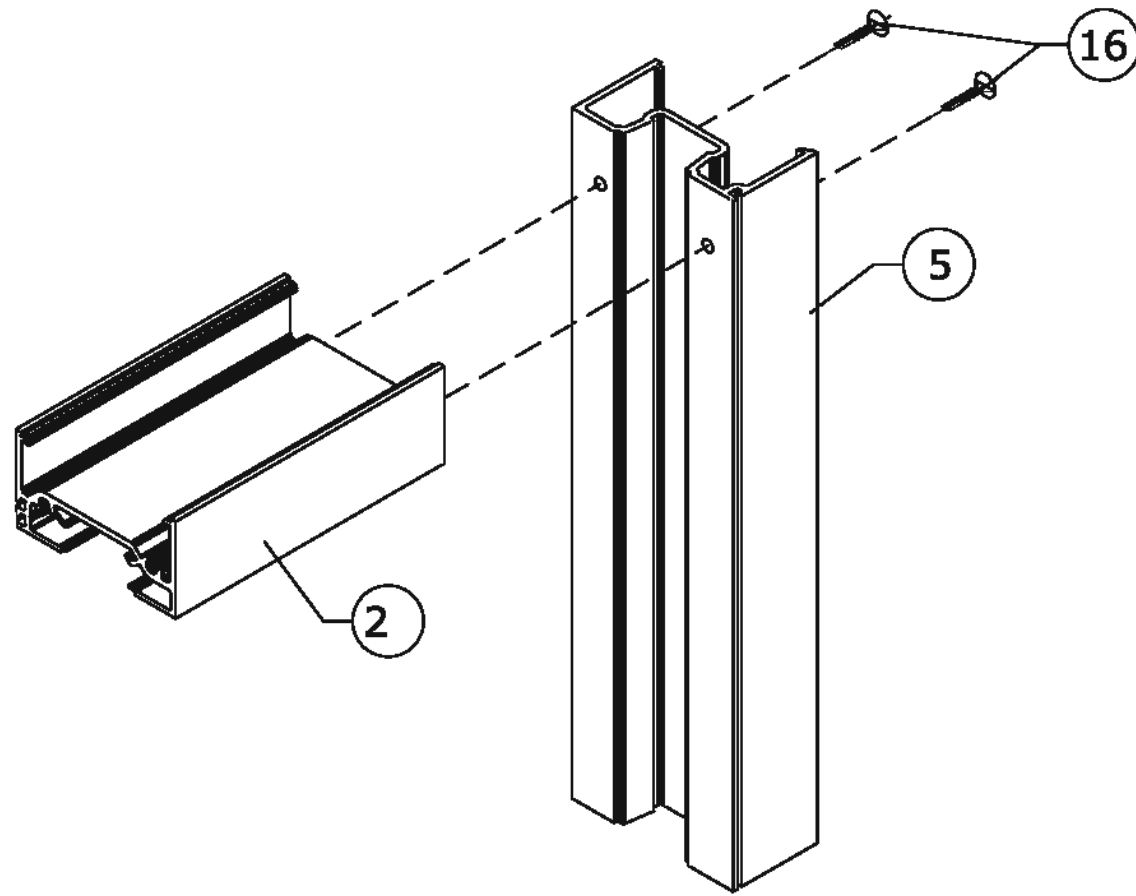

FRAME TOP/BOTTOM CORNERS

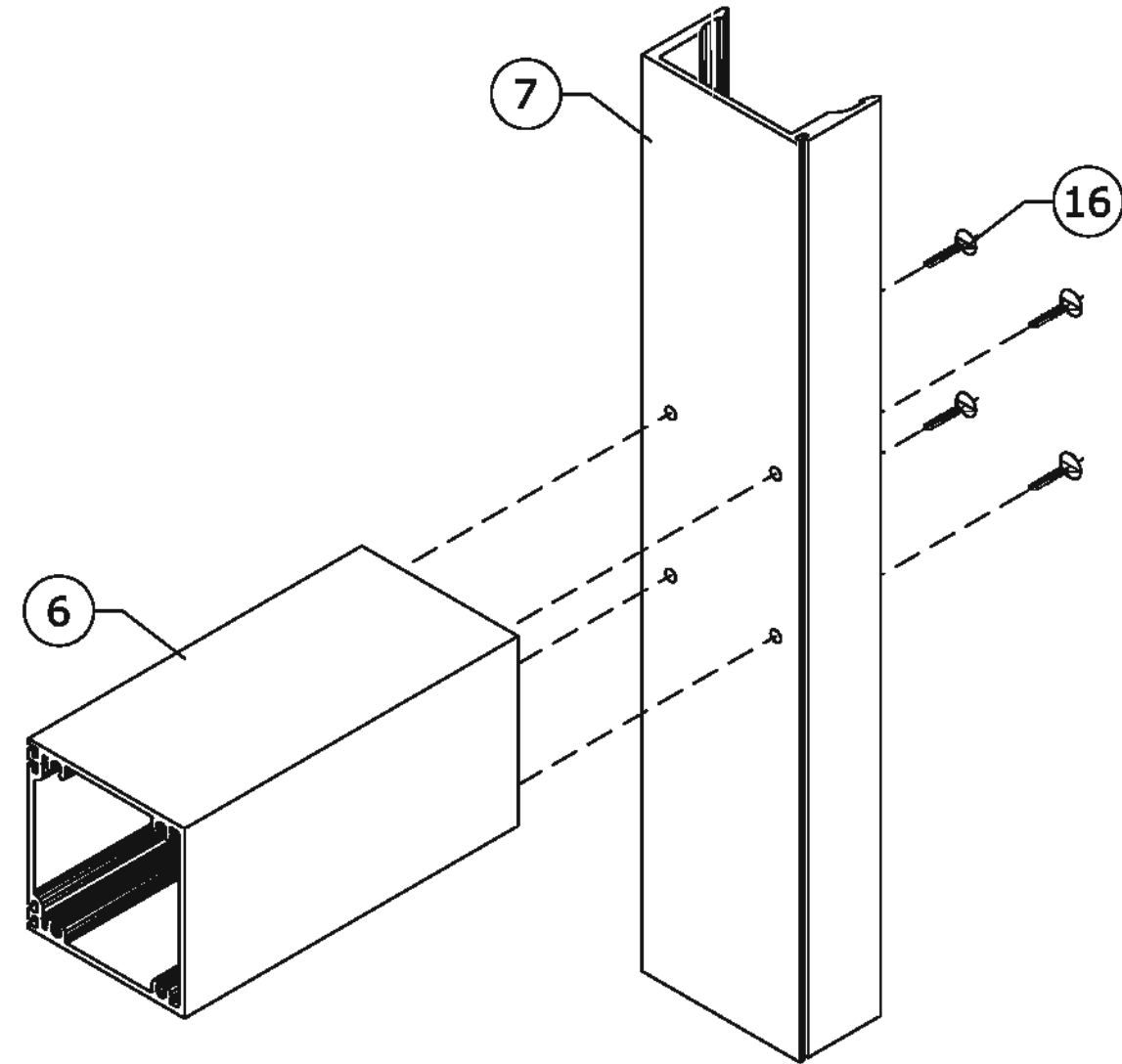

FRAME HORIZONTAL CORNER



ENGINEERING EXPRESS
CORPORATE OFFICE:
160 SW 12th AVE, SUITE 106
DEERFIELD BEACH, FL 33442
(954) 354-0660 | (866) 396-9999
TEAM@ENGINEERINGEXPRESS.COM
ENGINEERINGEXPRESS.COM

CRAWFORD TRACEY CORPORATION

3301 S.W. 13th DRIVE
DEERFIELD BEACH, FL, 33442-8101
Phn. (954) 698-6888

PRO-TECH 455G ALUMINUM CURTAINWALL SYSTEM
FLORIDA STATE APPROVAL

REMARKS	DRWN	CHKD	DATE
FBC 2020 UPDATE	JEM	AJP	10/19/20

THIS DOCUMENT IS THE PROPERTY OF ENGINEERING EXPRESS, AND SHALL NOT BE REPRODUCED IN WHOLE OR PART, WITHOUT WRITTEN CONSENT OF ENGINEERING EXPRESS. ALTERATIONS, ADDITIONS, OR OTHER MARKINGS TO THIS DOCUMENT ARE NOT PERMITTED AND INVALIDATE OUR CERTIFICATION.

COPYRIGHT ENGINEERING EXPRESS®

20-32267

SCALE: NTS UNLESS NOTED

35