

GENERAL NOTES

1. THE PRODUCT SHOWN HEREIN IS DESIGNED AND MANUFACTURED TO COMPLY WITH THE REQUIREMENTS OF THE 8TH EDITION (2023) FLORIDA BUILDING CODE FOR USE OUTSIDE THE HIGH VELOCITY HURRICANE ZONE
2. THIS DOCUMENT ADDRESSES ONLY PRODUCT ANCHORAGE TO ACHIEVE THE INDICATED DESIGN PRESSURES AT THE INDICATED SIZES, IN THE CONFIGURATIONS INDICATED. INSTALL PRODUCTS WITH MAXIMUM SHIM GAP, MINIMUM EDGE DISTANCE AND EMBEDMENT, AND WITH FASTENER TYPE AS SHOWN IN THE DETAILS AND AS INDICATED IN TABLE 1. FOR FULL PRODUCT CONSTRUCTION DETAILS SEE ATI/INTERTEK TEST REPORTS J9467/68.01-201-47-R0
3. THIS PRODUCT AS SHOWN IN THIS DRAWING IS NON-IMPACT, AND REQUIRES THE USE OF IMPACT PROTECTIVE DEVICES (SHUTTERS) IN WINDBORNE DEBRIS REGIONS.
4. GLAZING SHALL BE COMPLIANT WITH ASTM E-1300.
5. THE 4/3 ALLOWABLE STRESS INCREASE FACTOR (SHORT-TERM INCREASE FACTOR) HAS NOT BEEN USED IN THE ANCHOR ANALYSIS FOR THIS SYSTEM. THE 1.6 Cd FACTOR WAS USED IN THE ANALYSIS OF ANCHORAGE INTO WOOD SUBSTRATE.
6. THE OPENING SUBSTRATE MATERIALS (FRAMING, MASONRY, BUCKS) AND ATTACHMENT OF BUCKS TO THE SUBSTRATE ARE BY OTHERS AND SHALL BE VERIFIED BY THE ARCHITECT OR ENGINEER OF RECORD OR AS APPROVED BY THE AUTHORITY HAVING JURISDICTION (AHJ). BUCKING, OPENINGS, & BUCKING FASTENERS MUST BE PROPERLY DESIGNED & INSTALLED BY OTHERS IN ACCORDANCE WITH THE FBC TO TRANSFER SUPERIMPOSED LOADS TO THE STRUCTURE. WITH MASONRY OPENINGS, WOOD BUCKS ARE OPTIONAL.
7. DISSIMILAR MATERIALS THAT COME INTO CONTACT SHALL BE COATED OR OTHERWISE PROTECTED TO PREVENT GALVANIC REACTIONS. WOOD BUCKS, IF USED, SHALL BE PRESSURE TREATED, WITH EITHER A TREATMENT OR COATING COMPATIBLE WITH THIS PRODUCT.
8. ANCHORAGE NOTES: ALL ANCHORS USED SHALL BE OF A MATERIAL OR HAVE A COATING COMPATIBLE WITH THE PRESSURE TREATED WOOD BUCKS AND ALL OTHER WINDOW MATERIALS. INSTALL ONE ANCHOR AT EACH LOCATION SHOWN IN THE ELEVATION. INSTALL SHIMS AT EACH ANCHOR LOCATION WHERE A GAP OF 1/16" OR GREATER EXISTS BETWEEN PRODUCT FRAME AND SUBSTRATE. SHIMS SHALL BE LOAD-BEARING (PLASTIC OR METALLIC) AND CAPABLE OF TRANSFERRING LOADS TO SUBSTRATE. SPECIFIED ANCHOR EMBEDMENT TO SUBSTRATE SHALL BE BEYOND WALL FINISH OR STUCCO.
9. WOOD BUCKS LESS THAN 1-1/2" THICK ARE OPTIONAL AND MAY BE USED WITH CONCRETE/CMU, WITH ANCHOR EMBEDMENT BEYOND WOOD BUCKS AND INTO MASONRY.
10. ALL HARDWARE & FASTENERS SHALL BE IN ACCORDANCE WITH THESE DRAWINGS, OR AS APPROVED, SIGNED, AND SEALED BY A FLORIDA-REGISTERED PROFESSIONAL ENGINEER ON A SITE-SPECIFIC BASIS.
11. SEALING AND FLASHING STRATEGIES FOR OVERALL WATER INFILTRATION RESISTANCE OF THE INSTALLED PRODUCT SHALL BE THE RESPONSIBILITY OF OTHERS AND ARE NOT ADDRESSED BY THIS DOCUMENT.

MODERN CASEMENT PICTURE

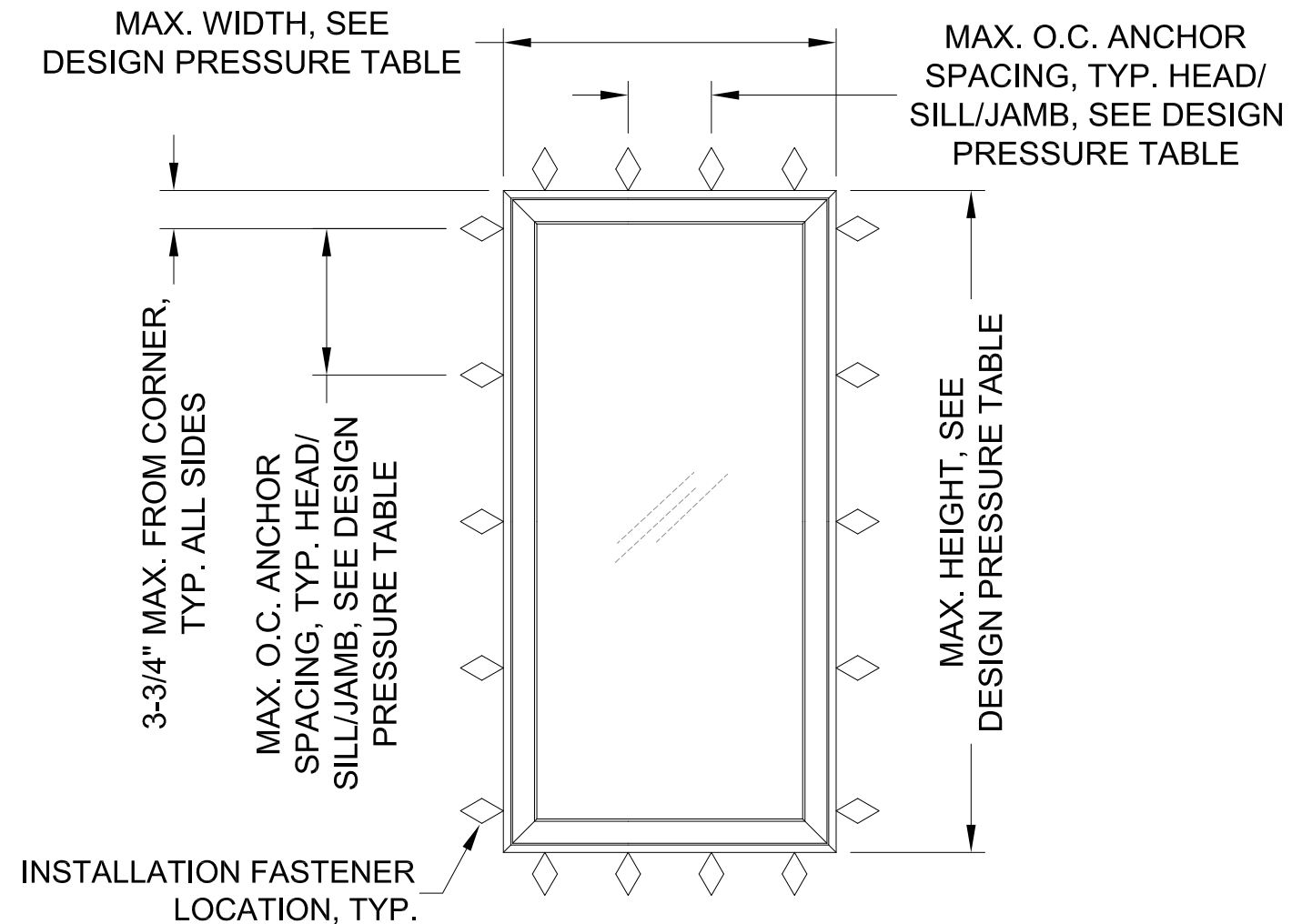

**ELEVATION
SEE DETAILS SHEET 2**

DESIGN PRESSURE TABLE

CONFIGURATION	MAX. SIZE*	DESIGN PRESSURE RATING	MAX. ANCHOR SPACING
MCAP	96" X 84"	+/-50 PSF	9-1/4"
MCAP	102" X 79"	+/-50 PSF	9-3/4"
MCAP	102" X 64"	+/-50 PSF	12"
MCAP	102" X 51"	+/-50 PSF	15"

* NOTE: WIDTH AND HEIGHT MAY BE SWAPPED

MARVIN  WARROAD, MN U.S.A.
PH. (218) 386-1430

SHEET DESCRIPTION: NOTES, ELEVATION	DATE DRAWN: 4/30/2020
SCALE: NTS	REV: B
DRAWING: Install-MCAP (FL29656)	SHEET: 1 OF 2

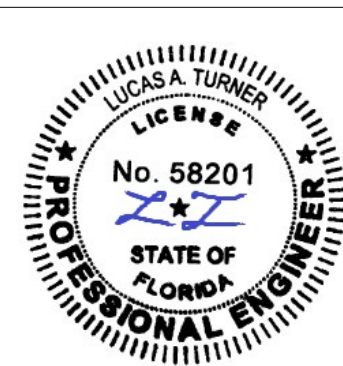

12/20/2023
Lucas A. Turner, P.E.
FL PE #58201
2428 Old Natchez Trace
Trail, Camden, TN 38320
Ph. 941-380-1574

MODERN CASEMENT PICTURE

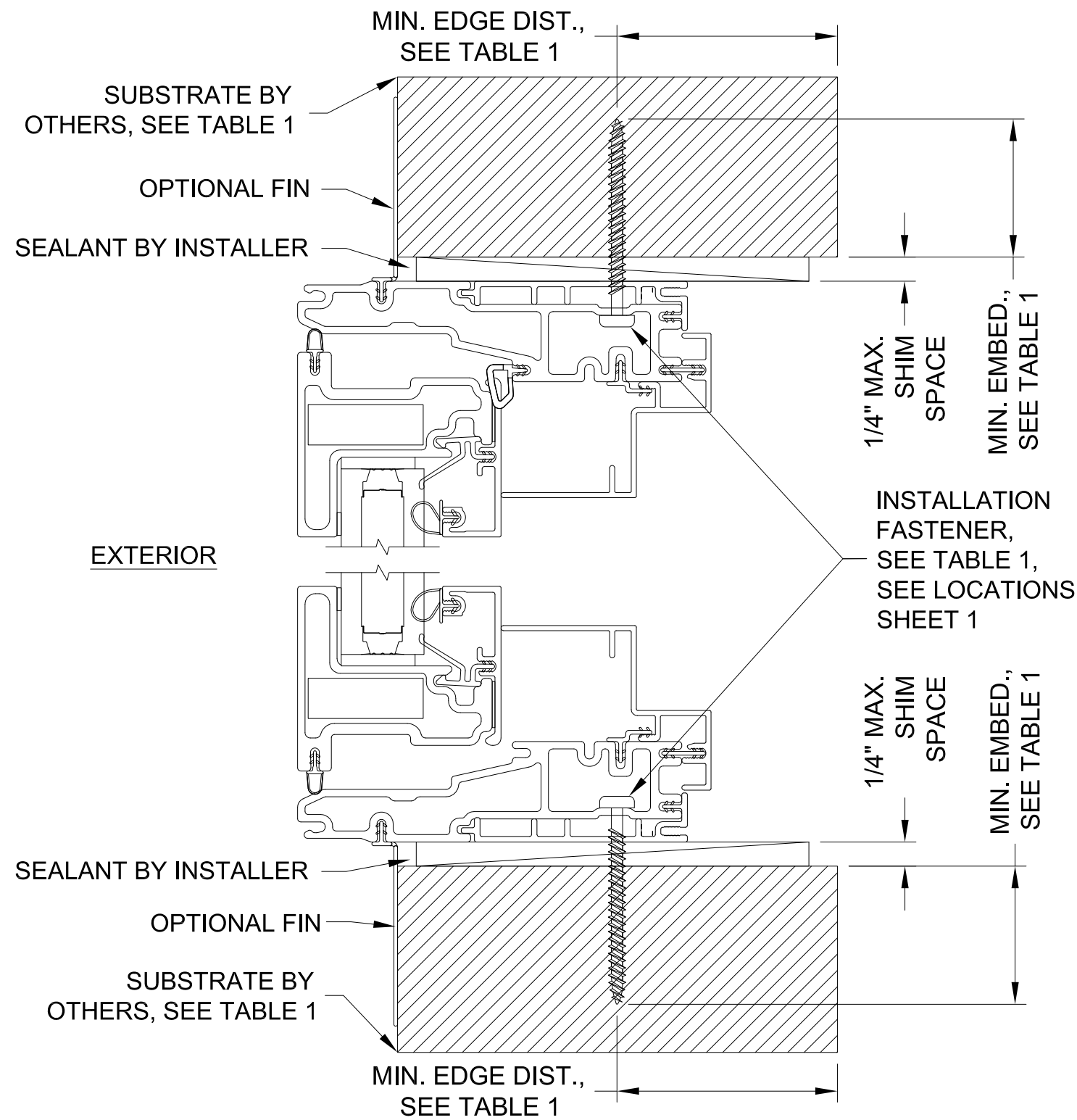

TYPICAL FRAME VERTICAL SECTION

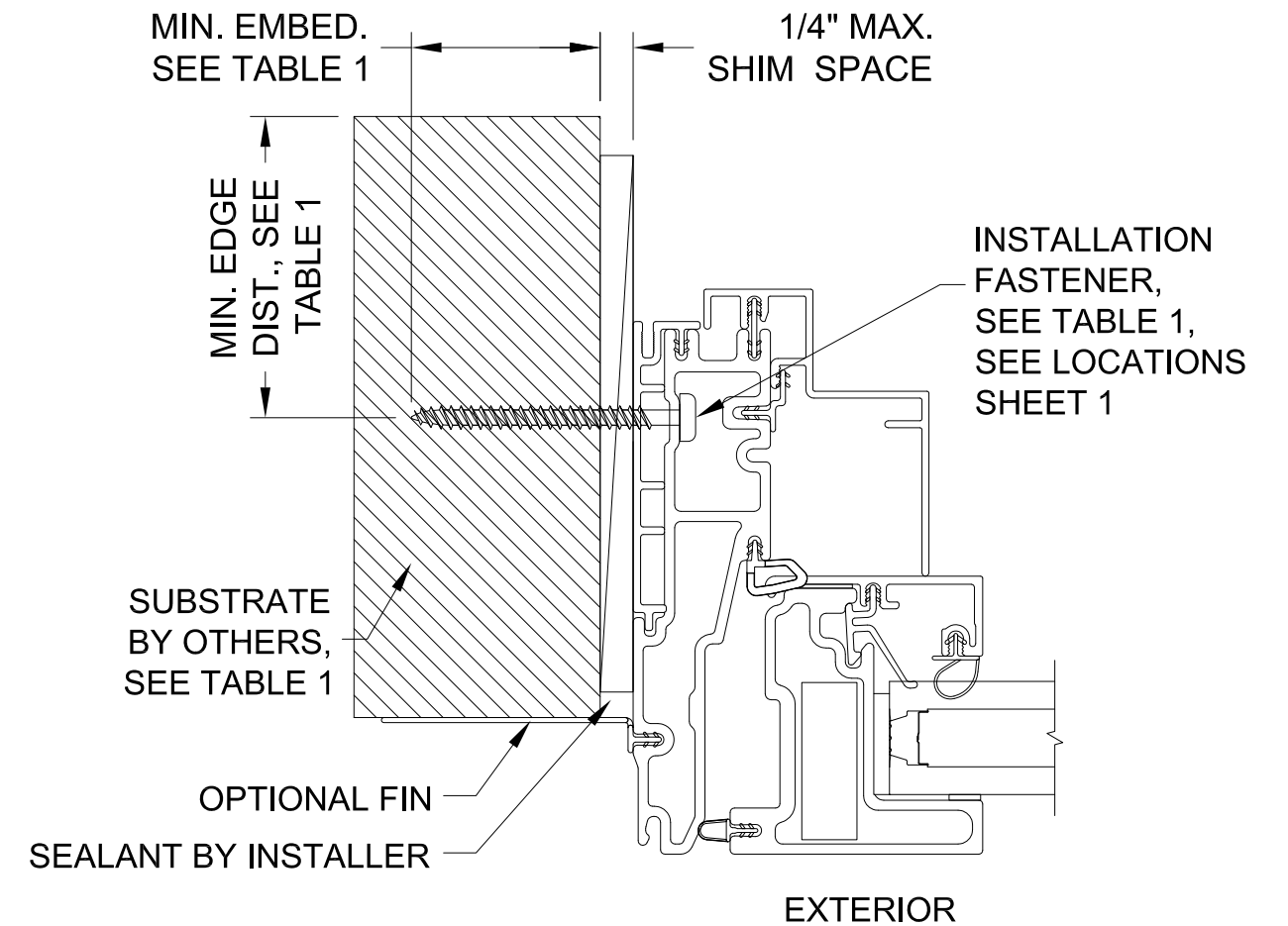

TYPICAL JAMB HORIZONTAL SECTION

TABLE 1: FRAME INSTALLATION ANCHOR REQUIREMENTS TABLE

SUBSTRATE TYPE	ANCHOR TYPE	MIN. EMBED.	MIN. EDGE DIST.
CONCRETE (3.05 KSI MIN)	3/16" DEWALT ULTRACON+	1-3/4"	1"
HOLLOW OR GROUT-FILLED CMU (ASTM C-90)	3/16" DEWALT ULTRACON+	1-1/4"	2-1/2"
16 GAUGE (0.060") MIN. STEEL STUD, 33KSI YIELD MIN., OR 1/8" ALUM. 6063-T5 MIN.	#10-16 HILTI KWIK-FLEX OR ITW TEKS SELF-DRILLING SCREW	3 THREADS BEYOND METAL WALL	1/2"

MARVIN  WARROAD, MN U.S.A.
PH. (218) 386-1430

SHEET DESCRIPTION: INSTALLATION DETAILS, TABLE	DATE DRAWN: 4/30/2020
SCALE: NTS	REV: B
DRAWING: Install-MCAP (FL29656)	SHEET: 2 OF 2

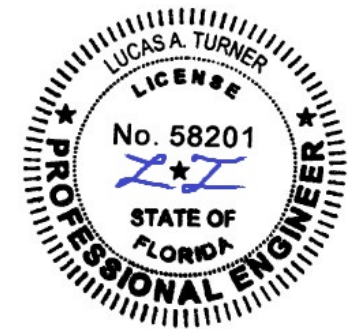

12/20/2023
Lucas A. Turner, P.E.
FL PE #58201
2428 Old Natchez Trace
Trail, Camden, TN 38320
Ph. 941-380-1574