

JAMB SCREW INSTALLATION

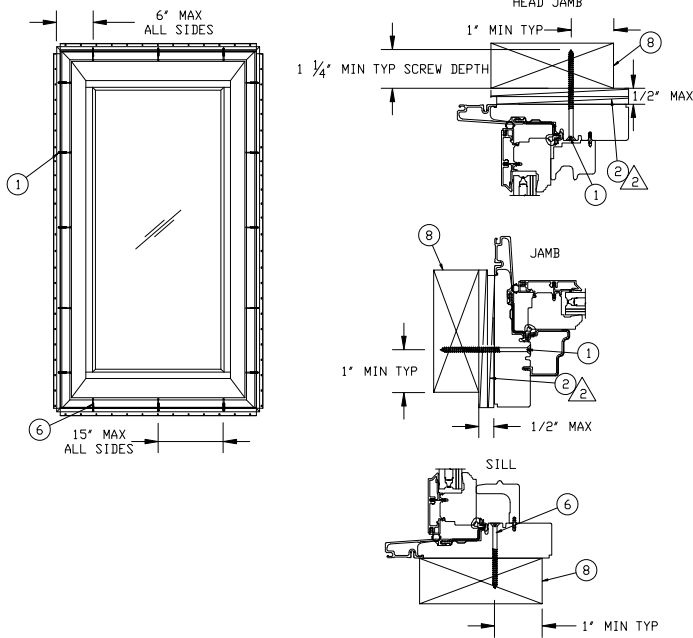

JAMB SCREW INSTALLATION METHOD:
 - UNIT MUST NOT BE IN DIRECT CONTACT WITH EITHER CONCRETE OR TREATED BUCK MATERIAL. IF SHIM SPACE IS LESS THAN 1/8" WRAPPING THE UNIT ON ALL 4 SIDES WITH WINDOW FLASHING TAPE IS REQUIRED AS A BARRIER BETWEEN THE UNIT AND CONCRETE OR TREATED LUMBER.
 - SECURE JAMBS AND HEAD JAMBS WITH #8 X 3" SCREWS.
 - SECURE THE SILL WITH #8 X 2 1/2" SCREWS.
 - SHIM AT EACH SCREW LOCATION.

STRUCTURAL BRACKET INSTALLATION

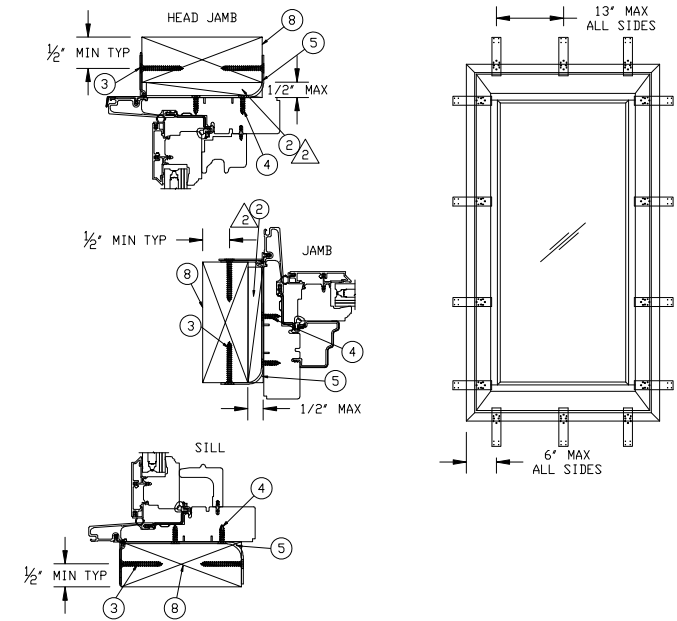

STRUCTURAL BRACKET INSTALLATION METHOD:
 - UNIT MUST NOT BE IN DIRECT CONTACT WITH EITHER CONCRETE OR TREATED BUCK MATERIAL. IF SHIM SPACE IS LESS THAN 1/8" WRAPPING THE UNIT ON ALL 4 SIDES WITH WINDOW FLASHING TAPE IS REQUIRED AS A BARRIER BETWEEN THE UNIT AND CONCRETE OR TREATED LUMBER.
 - ATTACH TO THE UNIT WITH TWO #8 X 3/8" SCREWS.
 - ATTACH TO THE BUCK WITH TWO #8 X 1 1/2" SCREWS ON EACH SIDE OF THE BUCK.
 - SCREWS MUST HAVE FULL EMBEDMENT.

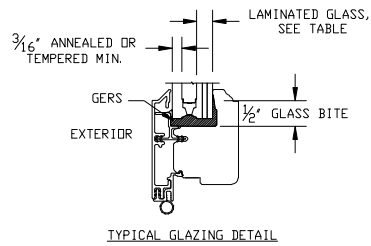

TYPE	LAMINATED GLASS MAKE UP
A	3.0mm(.122") ANN+ .090KURARAY PVB+ 3.0mm(.122") ANN

UNIT	MAX FRAME SIZE	DP RATING	GLASS OPTION
UL CSMNT PD IZ3	36 X 83 1/8	+65/-65	TYPE A

- NOTES FOR ALL METHODS:
 1. THIS PRINT IS FOR STRUCTURAL PERFORMANCE ONLY. FOR FLASHING & SEALING INSTRUCTIONS, REFER TO THE INSTALLATION INSTRUCTIONS.
 2. SHIMS
 - PLACE A SHIM WITHIN 4-6 INCHES OF EACH CORNER AND SPACE ALL OTHERS EVENLY A MAXIMUM OF 15" APART.
 3. IF CHEMICALLY TREATED LUMBER IS USED FOR BUCK MATERIAL, FASTENERS INTO THE BUCK MUST BE A MINIMUM OF 0.90 OZ/FT² ZINC HOT DIPPED GALVANIZED OR STAINLESS STEEL TYPE 304 OR 316.
 4. RECTANGULAR UNIT SHOWN, SHAPED UNITS ALSO APPLY.

8	WOOD BUCK BY OTHERS
7	2 INCH ROOFING NAIL
6	#8 X 2 5/8" WOOD SCREW
5	STRUCTURAL BRACKET
4	#8 X 5/8" SCREW
3	#8 X 1 1/2" SCREW
2	SHIM
1	#8 X 3.000 WOOD SCREW

UNSPECIFIED TOLERANCES	
DECIMALS:	ANGLE DEG:
XX ± .03	± .5
XXX ± .012	
LINEAL:	FAB LINEAL:
+ N/A	± .016
- N/A	
MATERIAL:	N/A

MARVIN		RESEARCH & DEVELOPMENT	
PRODUCT CATEGORY:		ULTIMATE CASEMENT	
UNIT TYPE:		UCAPOIZ3	
DWG TYPE:		INSTALLATION	
DESCRIPTION:		INSTALLATION	
CHK:	SIZE:	CLASS:	DWG NO:
	B	MISC	00087889
APP:	SCALE:	DATE:	DWG BY:
	NA	10/07/13	BORNEMAN, SKIP
			SHEET:
			1 OF 1

NOTICE - CONFIDENTIAL INFORMATION

The information in this document is privileged and strictly confidential. The information contained herein shall be used only by Marvin Windows and Doors employees and by those agents or suppliers granted official written permission. If the reader of this document is not the intended recipient, or the employee or agent of the intended recipient, please delete this document from all data storage devices, and destroy all hard copies. Any unauthorized dissemination, distribution, copying or other use of the information contained in this document is strictly prohibited.