

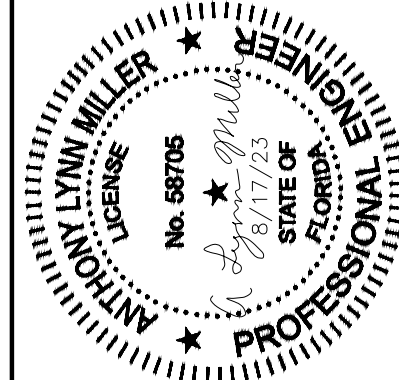

**MODEL 1840 DOUBLE HUNG WINDOW,
NON-IMPACT RESISTANT,
EQUAL-LEG, INTEGRAL FIN & FIN-FLANGE FRAMES**

DP RATING	NOT RATED FOR IMPACT RESISTANCE
± 50 PSF	



A. LYNN MILLER, P.E., P.E.# 58705

1) THIS PRODUCT HAS BEEN DESIGNED & TESTED TO COMPLY WITH THE REQUIREMENTS OF THE FLORIDA BUILDING CODE, EXCLUDING THE HIGH VELOCITY HURRICANE ZONE (HVHZ).

2) SHUTTERS ARE REQUIRED WHEN USED IN WIND-BORNE DEBRIS REGIONS.

3) MASONRY ANCHORS MAY BE USED INTO WOOD. ALL WOOD BUCKS LESS THAN 1-1/2" THICK ARE TO BE CONSIDERED 1X INSTALLATIONS. 1X WOOD BUCKS ARE OPTIONAL IF UNIT IS INSTALLED DIRECTLY TO SUBSTRATE. WOOD BUCKS DEPICTED AS 2X ARE 1-1/2" THICK OR GREATER.

4) ANCHOR EMBEDMENT TO BASE MATERIAL SHALL BE BEYOND WALL DRESSING OR STUCCO. USE ANCHORS OF SUFFICIENT LENGTH.

5) MAX. 1/4" SHIMS ARE REQUIRED AT EACH ANCHOR LOCATION WHERE THE PRODUCT IS NOT FLUSH TO THE SUBSTRATE. USE SHIMS CAPABLE OF TRANSFERRING APPLIED LOADS.

6) THE ANCHORAGE METHODS SHOWN HAVE BEEN DESIGNED TO RESIST THE WIND LOADS CORRESPONDING TO THE REQUIRED DESIGN PRESSURE. THE 33-1/3% STRESS INCREASE HAS NOT BEEN USED IN THE DESIGN OF THIS PRODUCT. THE 1.6 LOAD DURATION FACTOR WAS USED FOR THE EVALUATION OF ANCHORS INTO WOOD. ANCHORS THAT COME INTO CONTACT WITH OTHER DISSIMILAR MATERIALS SHALL MEET THE REQUIREMENTS OF THE FLORIDA BUILDING CODE FOR CORROSION RESISTANCE.

7) FRAME FLANGES OR INTEGRAL FINNS MAY BE TRIMMED IN-FIELD TO CREATE AN EQUAL LEG FRAME.

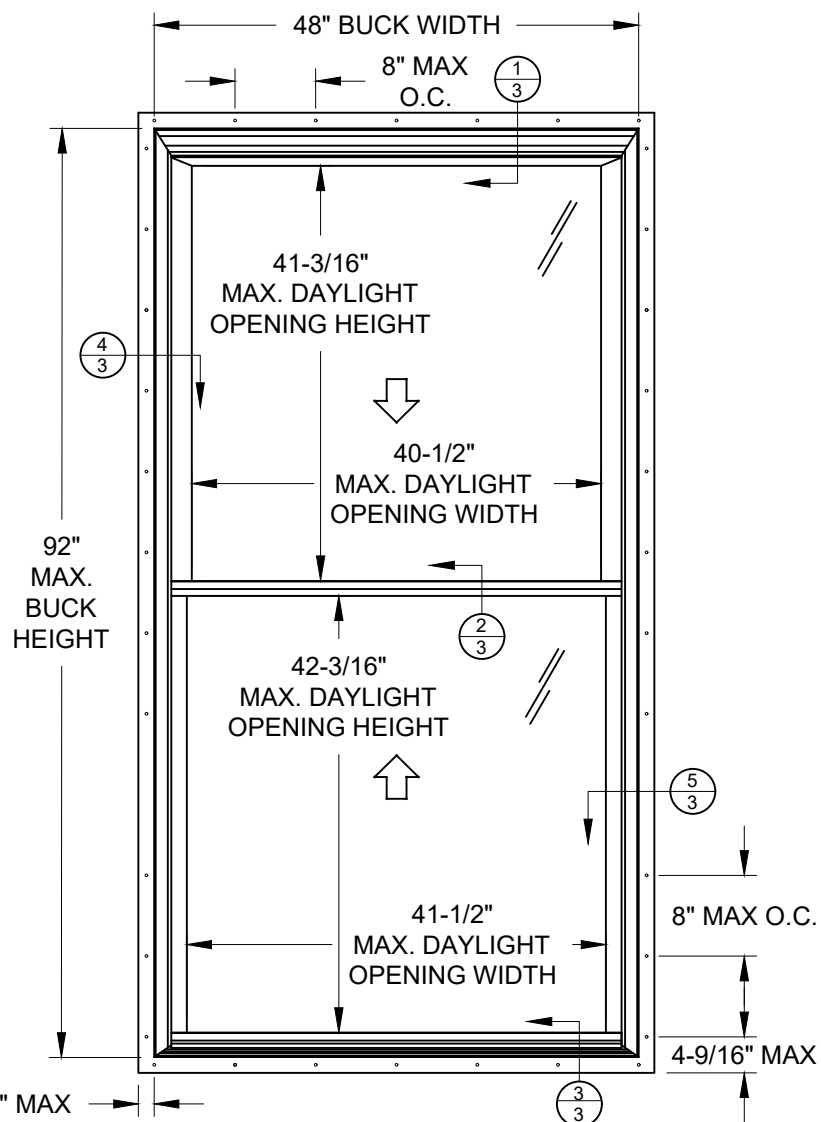

TYP. ANCHOR LOCATIONS @ TESTED SIZE (FIN, FIN/FLANGE FRAME SHOWN) (SAME ANCHORAGE APPLIES TO 54"x84" SIZE)

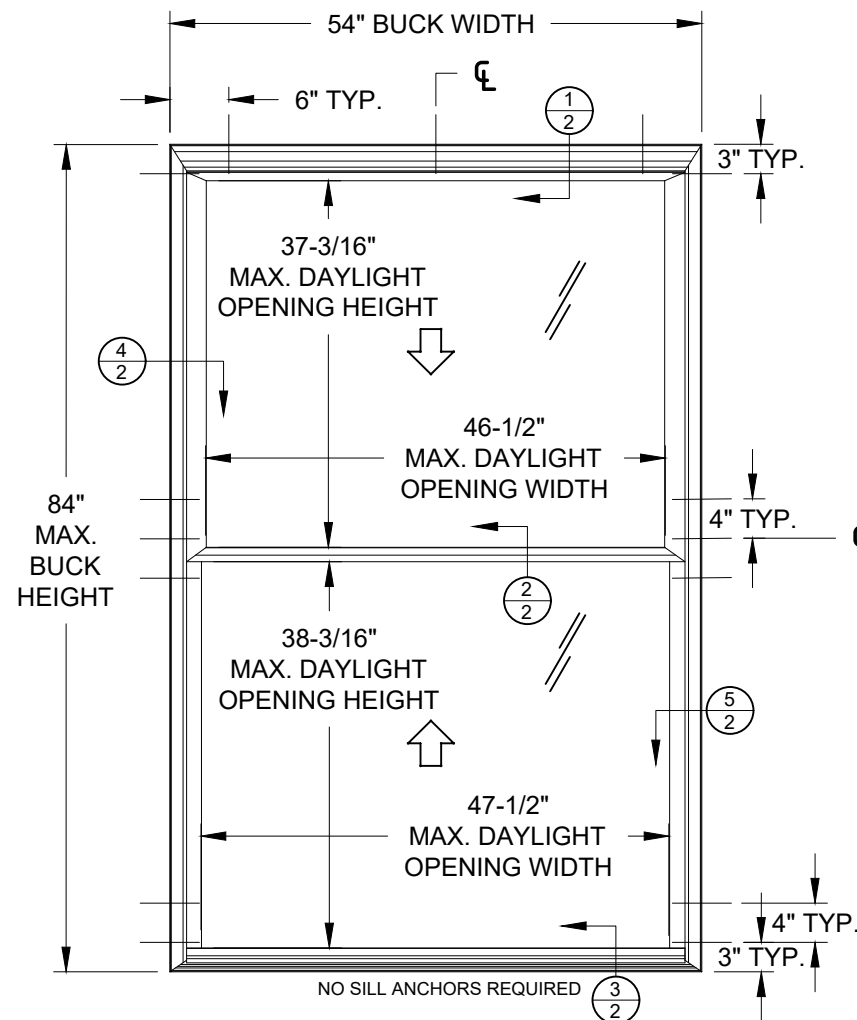

TYP. ANCHOR LOCATIONS @ TESTED SIZE (EQUAL-LEG FRAME SHOWN) (SAME ANCHORAGE APPLIES TO 48"x92" SIZE)

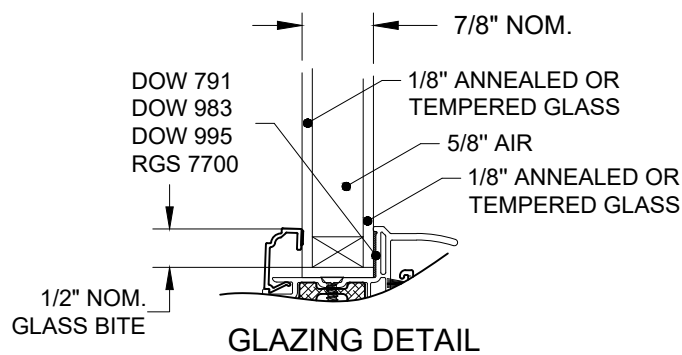
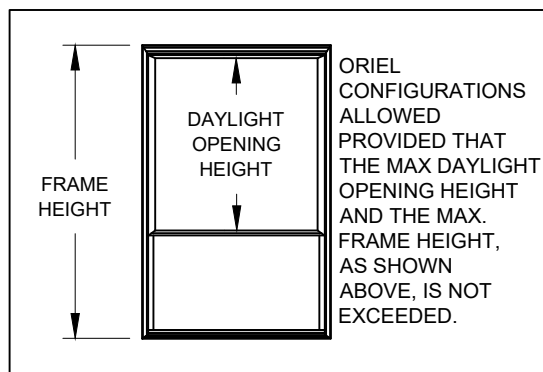

TABLE 1: DESIGN PRESSURES

Buck Width	Buck Height	Design Pressure	
		(+) psf	(-) psf
54"	84"	50.0	50.0
48"	92"	50.0	50.0

FOR SIZES NOT SHOWN, ROUND UP TO THE NEXT AVAILABLE WIDTH OR HEIGHT DIMENSION.

REGISTRATION #29296

COPYRIGHT © 2022
NEWSOUTH WINDOW SOLUTIONS
LIMITED LICENSE TO MAKE
COPIES FOR PERMITTING

PREPARED BY: A. LYNN MILLER, P.E.
1070 TECHNOLOGY DR
N. VENICE, FL 34275
(941)-480-1600

1840 SERIES DOUBLE HUNG
GENERAL NOTES, DESIGN PRESSURES,
GLAZING DETAILS & ANCHOR ELEVATION
NEWSOUTH WINDOW SOLUTIONS
10741 CROSSROADS COMMERCE BLVD.
TAMPA, FL 33610

BY:	AM
REVISION:	UPDATE: BOM PN. 17
DATE:	8/23
#:	1

DATE: 8/12/2022

SCALE: NTS

BY: LOGAN YODER

DRAWING #: DH1840-FPA-01

SHEET: 1 OF 5

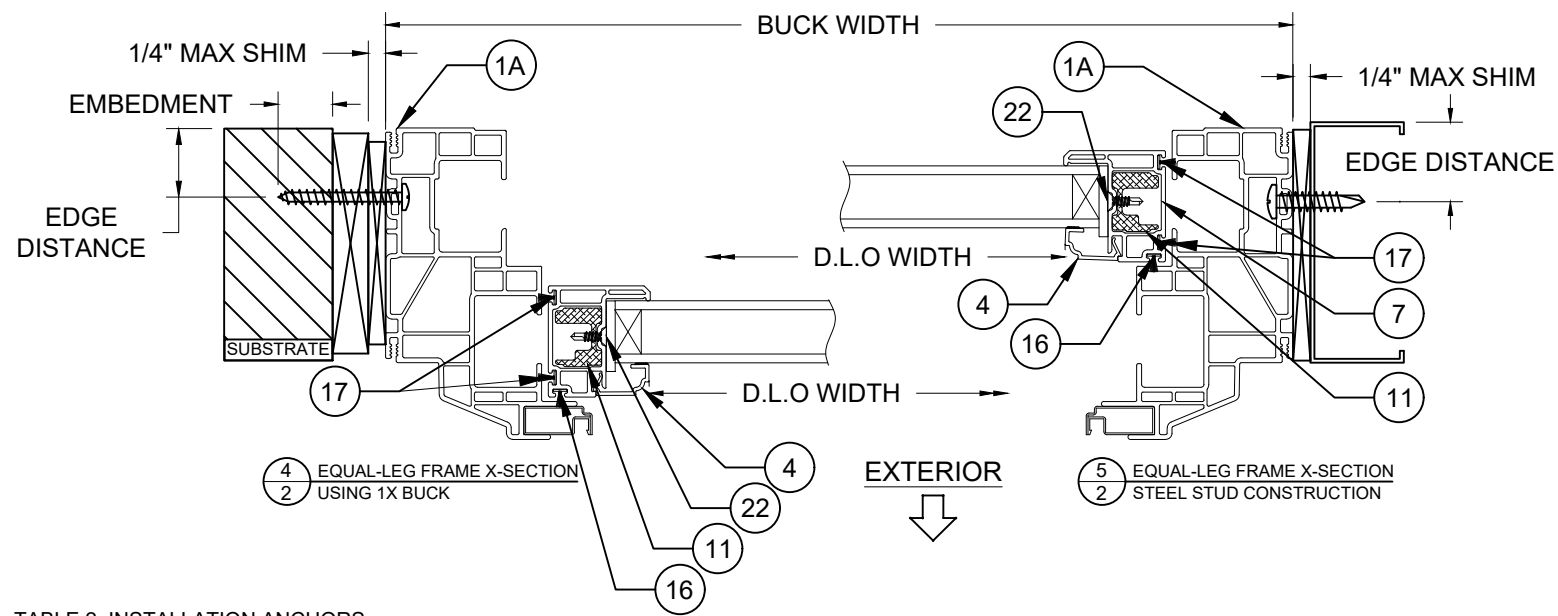
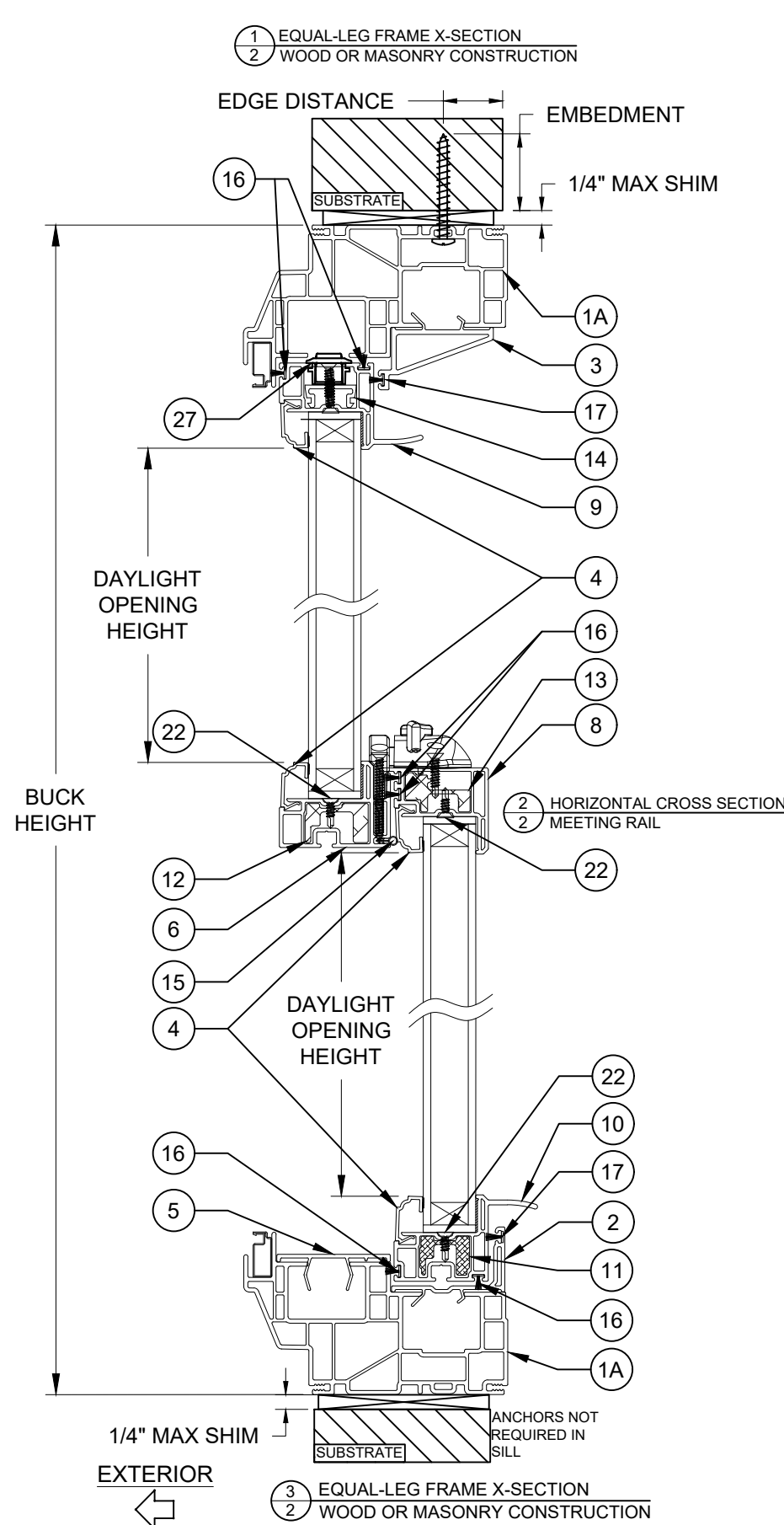

TABLE 2: INSTALLATION ANCHORS

Anchor	Substrate	Minimum Edge Distance	Minimum Embedment
#10 or #12 Steel or 410 SS Screw	Southern Pine (SG = .55)	1/2"	1-3/8"
	Aluminum, 6063-T5 min.	5/16"	0.045"
	Steel Stud, Gr. 33 min.	5/16"	0.035" (20 Ga)
	A36 Steel	5/16"	0.035"
3/16" Steel Ultracon+	Concrete (min. 2.9 ksi)	1"	1-3/4"
	UngROUTED CMU, (ASTM C-90)	1-1/4"	1-1/4"
	Southern Pine (SG = .55)	1/2"	1-3/8"
1/4" Steel Ultracon+	Concrete (min. 3.0 ksi)	1"	1-3/8"
	UngROUTED CMU, (ASTM C-90)	1"	1-1/4"
	Southern Pine (SG = .55)	1"	1-3/8"

- ANCHOR MUST EXTEND A MINIMUM OF 3 THREADS BEYOND ANY METAL SUBSTRATE
- "UNGROUTED CMU" VALUES MAY BE USED FOR GROUDED CMU APPLICATIONS
- ALL ANCHOR HEAD TYPES ARE APPLICABLE

INSTALLATION NOTES:

- SEE SHEET 1 FOR ANCHOR SPACING REQUIREMENTS.
- ANY INSTALLATION OPTION SHOWN (2X BUCK OR WOOD FRAMING, 1X BUCK, DIRECT TO MASONRY, STEEL STUD) MAY BE USED ON ANY SIDE OF THE WINDOW.
- USE ONLY SUBSTRATE APPROPRIATE ANCHORS LISTED IN ANCHOR TABLE 2. FOLLOW EMBEDMENT AND EDGE DISTANCE LIMITS. MAX. SHIM THICKNESS TO BE 1/4".

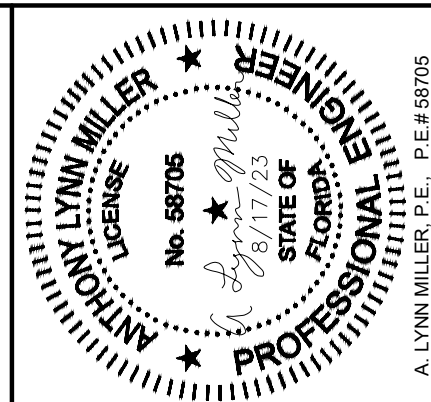

A. LYNN MILLER, P.E., P.E.# 58705

REGISTRATION #29296
 COPYRIGHT © 2022
 NEWSOUTH WINDOW SOLUTIONS
 LIMITED LICENSE TO MAKE
 COPIES FOR PERMITTING

PREPARED BY: A. LYNN MILLER, P.E.
 1070 TECHNOLOGY DR
 N. VENICE, FL 34275
 (941)-480-1600

1840 SERIES DOUBLE HUNG
 INSTALLATION DETAILS - EQUAL-LEG FRAME
 NEWSOUTH WINDOW SOLUTIONS
 10741 CROSSROADS COMMERCE BLVD.
 TAMPA, FL 33610

BY:	AM
REVISION:	UPDATE: BOM PN. 17
DATE:	8/23
#:	1
DATE:	8/12/2022
SCALE:	NTS
BY:	LOGAN YODER
DRAWING #:	DH1840-FPA-01
SHEET:	2 OF 5

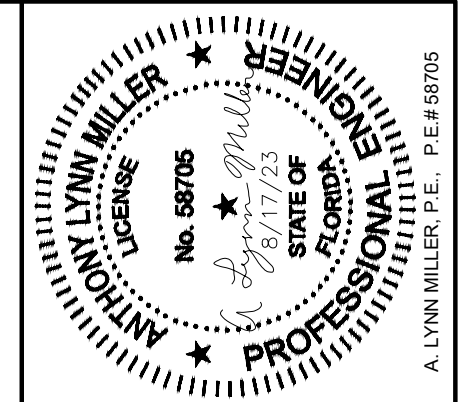

A. LYNN MILLER, P.E., P.E.# 58705

REGISTRATION #29296
 COPYRIGHT © 2022
 NEWSOUTH WINDOW SOLUTIONS
 LIMITED LICENSE TO MAKE
 COPIES FOR PERMITTING

PREPARED BY: A. LYNN MILLER, P.E.
 1070 TECHNOLOGY DR
 N. VENICE, FL 34275
 (941)-480-1600

1840 SERIES DOUBLE HUNG	BY:	AM
INSTALLATION DETAILS - FIN & FIN-FLANGE FRAME	REVISION:	
NEWSOUTH WINDOW SOLUTIONS 10741 CROSSROADS COMMERCE BLVD. TAMPA, FL 33610	DATE:	8/23
	#:	1
	DATE:	8/12/2022
	SCALE:	NTS
	BY:	LOGAN YODER
	DRAWING #:	DH1840-FPA-01
	SHEET:	3 OF 5

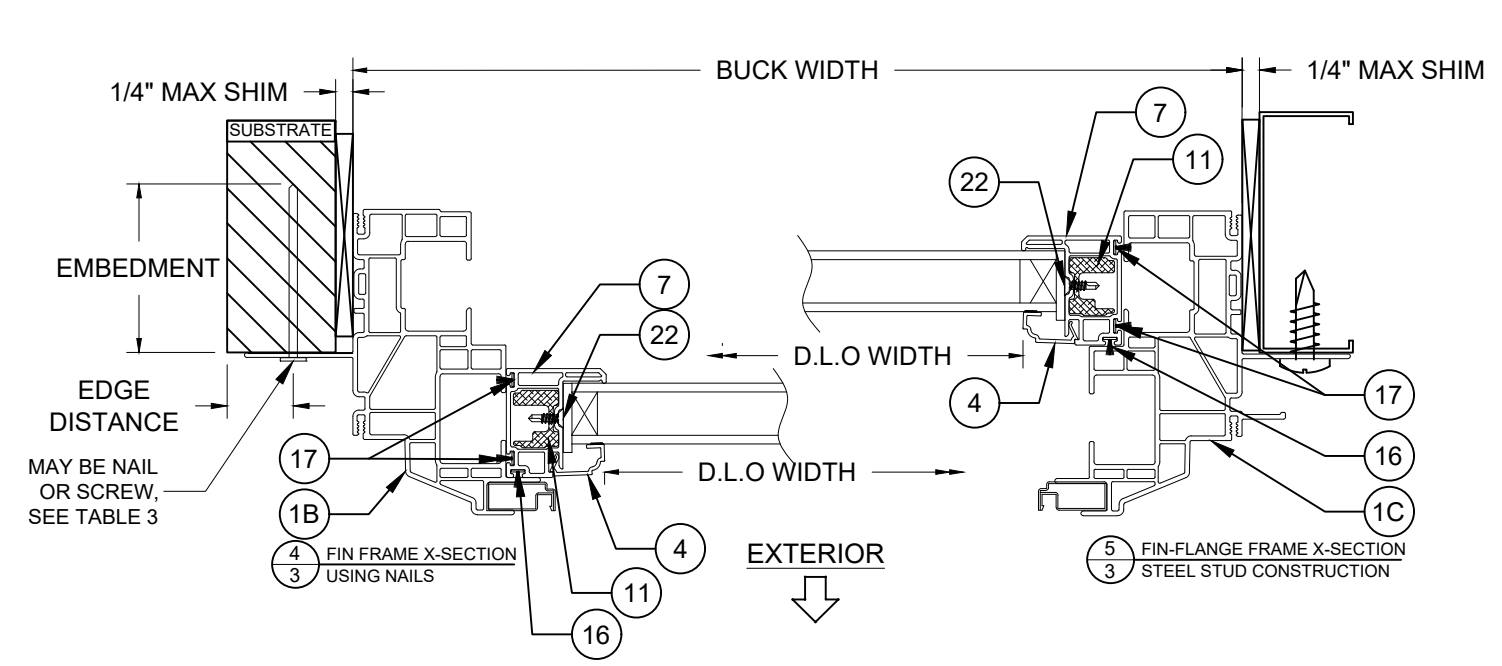
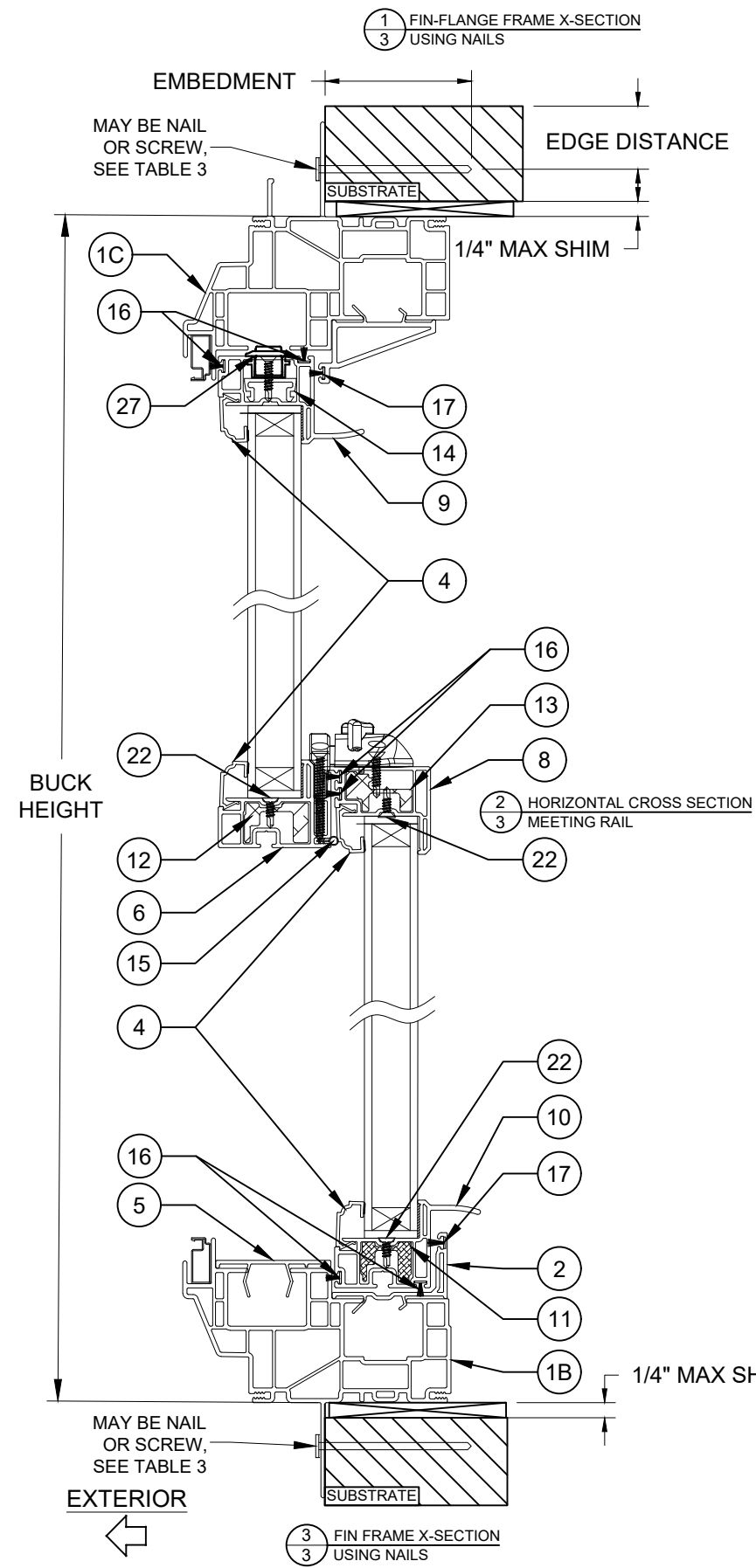

HYBRID CONFIGURATIONS (FLANGE FRAME/FIN FRAME)
 ALLOWED WITH MULLION INSTALLATION, SEE PAGE 2
 FOR FLANGE FRAME INSTALLATION DETAILS.

TABLE 3: INSTALLATION ANCHORS

Anchor	Substrate	Min. Edge Distance	Min. Embedment
2-1/2" x .113" Box Nail	P.T. Southern Pine (SG = .55)	5/16"	2-1/2"
2-1/2" x .131" Common Nail	P.T. Southern Pine (SG = .55)	3/8"	2-1/2"
2-1/2" x .145" Roofing Nail	P.T. Southern Pine (SG = .55)	3/8"	2-1/2"
#10 Steel SMS	P.T. Southern Pine (SG = .55)	1/2"	1-3/8"
	Aluminum, 6063-T5 min.	5/16"	0.045
	Steel Stud, Gr. 33 min.	5/16"	0.035 (20 ga)
	A36 Steel	5/16"	0.035

- ANCHOR MUST EXTEND A MINIMUM OF 3 THREADS BEYOND ANY METAL SUBSTRATE
- ALL ANCHOR HEAD TYPES ARE APPLICABLE

INSTALLATION NOTES:

- SEE SHEET 1 FOR ANCHOR SPACING REQUIREMENTS
- FLANGE AND/OR FIN MAY BE REMOVED TO CREATE OTHER FRAME TYPES.
- USE ONLY SUBSTRATE APPROPRIATE ANCHORS LISTED IN ANCHOR TABLE 3. FOLLOW EMBEDMENT AND EDGE DISTANCE LIMITS. ANY INSTALLATION OPTION SHOWN MAY BE USED ON ANY OR ALL SIDES OF THE WINDOW.
- MAX SHIM THICKNESS TO BE 1/4". MAX SHIM SPACING TO BE 18".

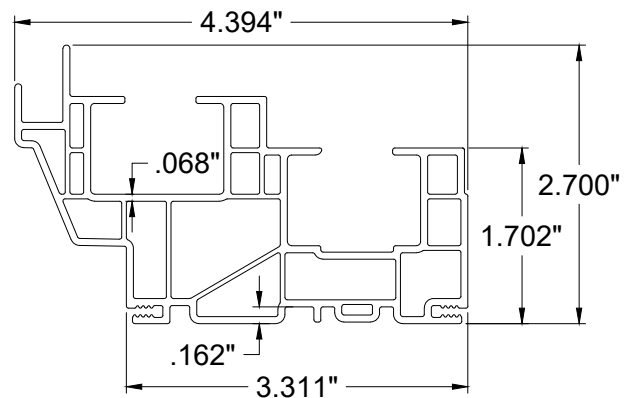

①A EQUAL-LEG FRAME

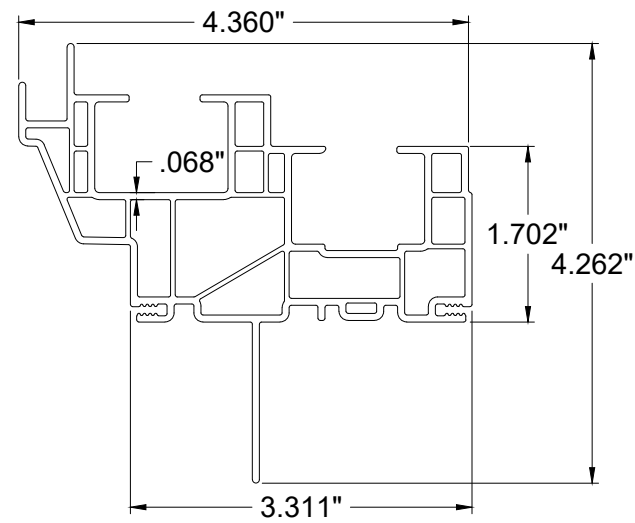

①B INTEGRAL FIN FRAME

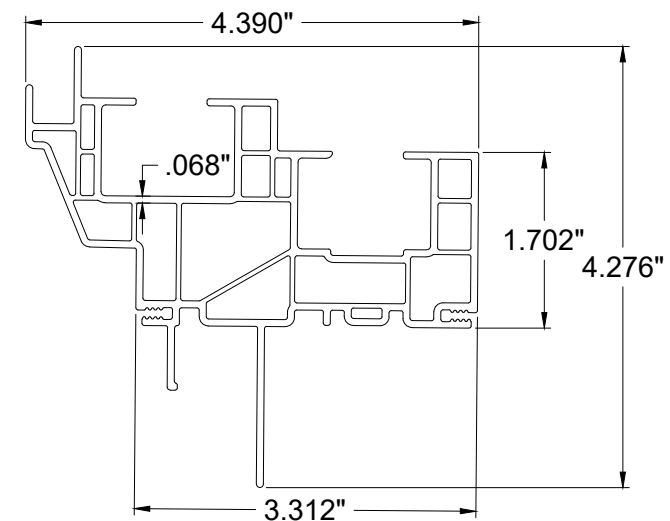

①C FIN/FLANGE FRAME

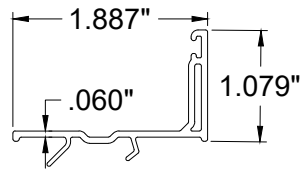

② SILL ADAPTER

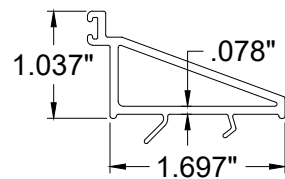

③ HEAD ADAPTER

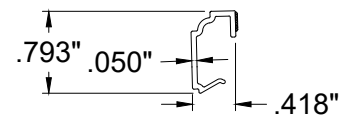

④ GLAZING BEAD (7/8" GLASS)

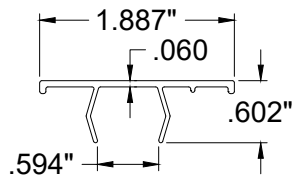

⑤ SASH ADAPTER

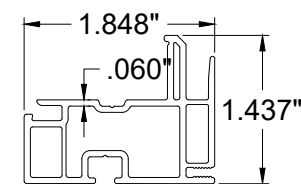

⑥ KEEPER RAIL

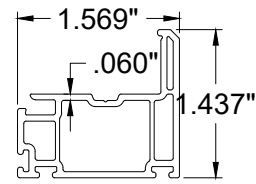

⑦ STILE

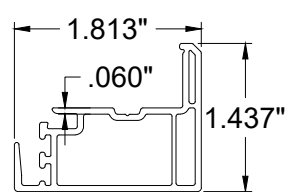

⑧ LOCK RAIL

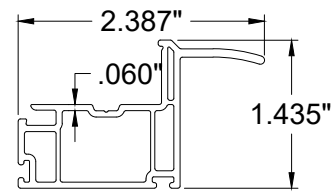

⑨ TOP PULL RAIL

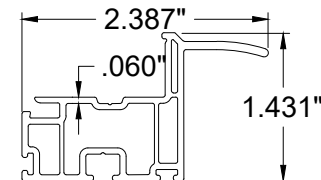

⑩ BOTTOM PULL RAIL

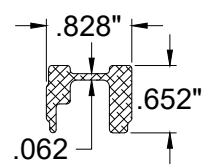

⑪ STILE REINFORCEMENT

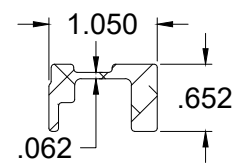

⑫ KEEPER RAIL REINFORCEMENT

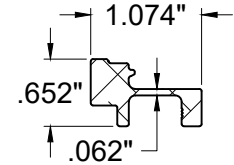

⑬ LOCK RAIL REINFORCEMENT

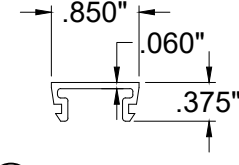

⑭ TOP PULL RAIL REINFORCEMENT

THE APPROVED RIGID PVC EXTERIOR EXTRUSIONS ARE TO BE PRODUCED BY EXTRUDERS' LICENSEES UNDER "AAMA CERTIFICATION PROGRAMS FOR RIGID PVC EXTRUSIONS".

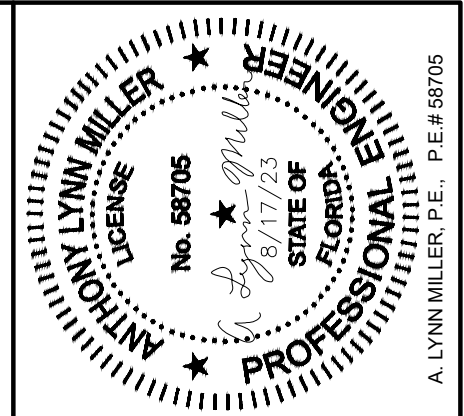

REGISTRATION #29296

COPYRIGHT © 2022
NEWSOUTH WINDOW SOLUTIONS
LIMITED LICENSE TO MAKE
COPIES FOR PERMITTING

PREPARED BY: A. LYNN MILLER, P.E.
1070 TECHNOLOGY DR
N. VENICE, FL 34275
(941)-480-1600

1840 SERIES DOUBLE HUNG
EXTRUSIONS
NEWSOUTH WINDOW SOLUTIONS
10741 CROSSROADS COMMERCE BLVD.
TAMPA, FL 33610

BY:	AM
REVISION:	
DATE:	8/23
#:	1
UPDATE:	BOM PN. 17

DATE: 8/12/2022
SCALE: NTS
BY: LOGAN YODER
DRAWING #: DH1840-FPA-01
SHEET: 4 OF 5

ITEM	DESCRIPTION	CBP PART #	MATERIAL/ DESCRIPTION
1A	EQUAL LEG MASTER FRAME	1813A	RIGID PVC
1B	NAIL FIN MASTER FRAME	1843AJ	RIGID PVC
1C	FIN-FLANGE MASTER FRAME	1843J	RIGID PVC
2	SILL ADAPTOR	1885	RIGID PVC
3	HEAD ADAPTER	1875	RIGID PVC
4	GLAZING BEAD	1876	RIGID PVC
5	SASH ADAPTER	1888	RIGID PVC
6	KEEPER RAIL	1817	RIGID PVC
7	STILE	1808	RIGID PVC
8	LOCK RAIL	1806	RIGID PVC
9	TOP PULL RAIL	1815	RIGID PVC
10	BOTTOM PULL RAIL	1805	RIGID PVC
11	STILE/BOTTOM PULL REINFORCEMENT	6113	6005A-T61
12	KEEPER RAIL REINFORCEMENT	6115	6005A-T61
13	LOCK RAIL REINFORCEMENT	6112	6063-T6
14	TOP PULL RAIL REINFORCEMENT	6114	6" / 6063-T6
15	KEEPER RAIL GASKET	pp1297 or E109	PP1297 for A1,A3
16	WSTP .187x.210	P-4026	GRAY
17	WSTP .187x.250	P-4028	BLACK
18	SPIRAL BALANCE	-	CALDWELL EZ-LIFT
19	COIL BALANCE	RT880-80	CALDWELL, ROLLER TILT 880
20	LOCK HOLDING SCREW	1007	#6 X 1-1/4" SMS
21	KEEPER HOLDING SCREW	1007	#6 X 1-1/4" SMS
22	REINFORCEMENT SCREW	1068	#6 X 5/8" FLAT TEK
23	INTERLOCK ADDER SCREW	1068	#6 X 5/8" FLAT TEK
26	PIVOT BAR	8148	6063-T6
27	TILT LATCH	825	TRUTH 46.13 / ZINC BODY AND PLUNGER, STEEL SPRING
28	INTERLOCK EXTENDERS LH&RH	8125 -LH/RH	LAWRENCE / NYLON
29	LOCK	8122	VISION HARDWARE / ZINC BODY AND CAM
30	KEEPER	8123	VISION HARDWARE / ZINC
31	REINFORCEMENT SCREW FOR SASH JAMB	1003	#6 X 1/2" FLAT TEK
32	REINFORCEMENT SCREW FOR TOP RAIL	1068	#6 X 5/8" FLAT TEK
33	REINFORCEMENT SCREW FOR BOTTOM RAIL	1068	#6 X 5/8" FLAT TEK
34	PIVOT BAR SCREW	-	#8 X 1/4" PHIL PAN (2 / PIVOT BAR)
35	TILT LATCH SCREW	-	#6 X 1/2 FLAT TEK
36	TOP PULL RAIL REINFORCEMENT SCREW	-	#6 X 3/4 FLAT TEK

BUCK ANCHORAGE DETAIL

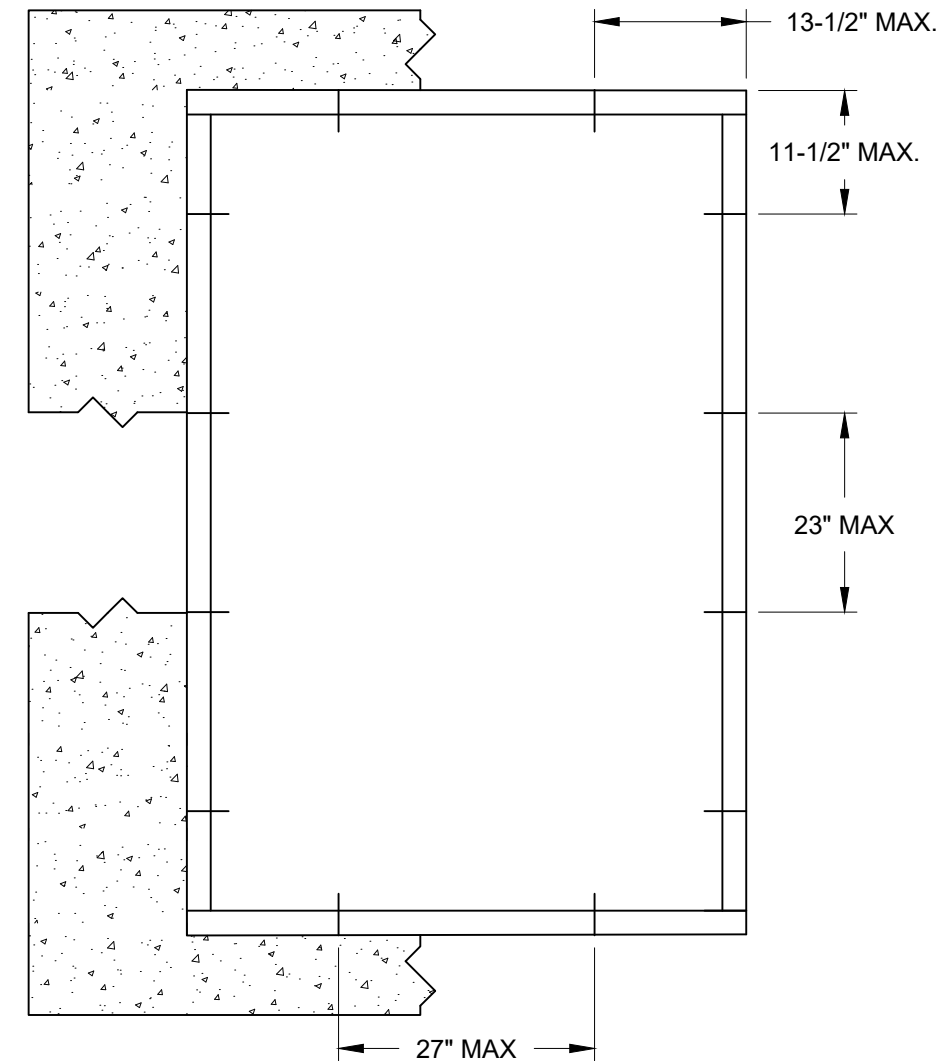

Anchor	Substrate	Minimum Edge Distance	Minimum Embedment
1/4" Steel Ultracon+	Concrete (min. 3.0 ksi)	1"	1-3/8"
	UngROUTED CMU, (ASTM C-90)	1"	1-1/4"

- 1) ANCHOR MUST EXTEND A MINIMUM OF 3 THREADS BEYOND ANY METAL SUBSTRATE.
- 2) FLATHEAD ANCHORS REQUIRED AT DOOR SILL. OTHER LOCATIONS MAY USE ANY HEAD TYPE.
- 3) MIN. #12 X 1" SMS TO BE USED FOR ALL MULLION APPLICATIONS.
- 4) FOR CASES WHERE SUBSTRATES VARY PER FRAME MEMBERS, USE THE HIGHEST ANCHOR GROUP LETTER FOR ALL SIDES.

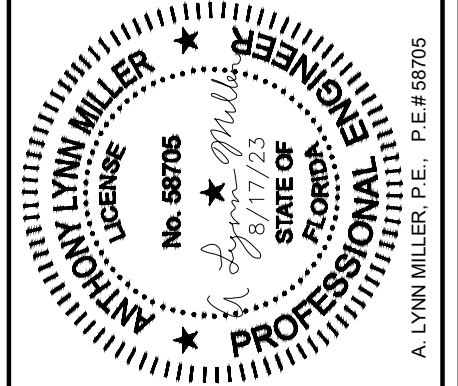

REGISTRATION #29296

COPYRIGHT © 2022
NEWSOUTH WINDOW SOLUTIONS
LIMITED LICENSE TO MAKE
COPIES FOR PERMITTING

PREPARED BY: A. LYNN MILLER, P.E.
1070 TECHNOLOGY DR
N. VENICE, FL 34275
(941)-480-1600

1840 SERIES DOUBLE HUNG
BILL OF MATERIALS & BUCK ANCHORAGE
NEWSOUTH WINDOW SOLUTIONS
10741 CROSSROADS COMMERCE BLVD.
TAMPA, FL 33610

BY:	AM
REVISION:	UPDATE: BOM PN. 17
DATE:	8/23
#:	1

DATE: 8/12/2022

SCALE: NTS

BY: LOGAN YODER

DRAWING # :
DH1840-FPA-01

SHEET: 5 OF 5