



SERIES 8000, MODEL 8400
DOUBLE HUNG WINDOW,
NON-IMPACT RESISTANT,
EQUAL SPLIT, EQUAL-LEG FRAME

FLORIDA PRODUCT APPROVAL #32346

DESIGN PRESSURE RATING
 VARIES, SEE TABLE 1

NOT RATED FOR
 MISSILE IMPACT
 RESISTANCE

1) THIS PRODUCT HAS BEEN DESIGNED & TESTED TO COMPLY WITH THE REQUIREMENTS OF THE FLORIDA BUILDING CODE, EXCLUDING THE HIGH VELOCITY HURRICANE ZONE (HVHZ).

2) SHUTTERS ARE REQUIRED WHEN USED IN WIND-BORNE DEBRIS REGIONS.

3) MASONRY ANCHORS MAY BE USED INTO WOOD. ALL WOOD BUCKS LESS THAN 1-1/2" THICK ARE TO BE CONSIDERED 1X INSTALLATIONS. 1X WOOD BUCKS ARE OPTIONAL IF UNIT IS INSTALLED DIRECTLY TO SUBSTRATE. WOOD BUCKS DEPICTED AS 2X ARE 1-1/2" THICK OR GREATER.

4) ANCHOR EMBEDMENT TO BASE MATERIAL SHALL BE BEYOND WALL DRESSING OR STUCCO. USE ANCHORS OF SUFFICIENT LENGTH.

5) MAX. 1/4" SHIMS ARE REQUIRED AT EACH ANCHOR LOCATION WHERE THE PRODUCT IS NOT FLUSH TO THE SUBSTRATE. USE SHIMS CAPABLE OF TRANSFERRING APPLIED LOADS.

6) THE ANCHORAGE METHODS SHOWN HAVE BEEN DESIGNED TO RESIST THE WIND LOADS CORRESPONDING TO THE REQUIRED DESIGN PRESSURE. THE 33-1/3% STRESS INCREASE HAS NOT BEEN USED IN THE DESIGN OF THIS PRODUCT. THE 1.6 LOAD DURATION FACTOR WAS USED FOR THE EVALUATION OF ANCHORS INTO WOOD. ANCHORS THAT COME INTO CONTACT WITH OTHER DISSIMILAR MATERIALS SHALL MEET THE REQUIREMENTS OF THE FLORIDA BUILDING CODE FOR CORROSION RESISTANCE.

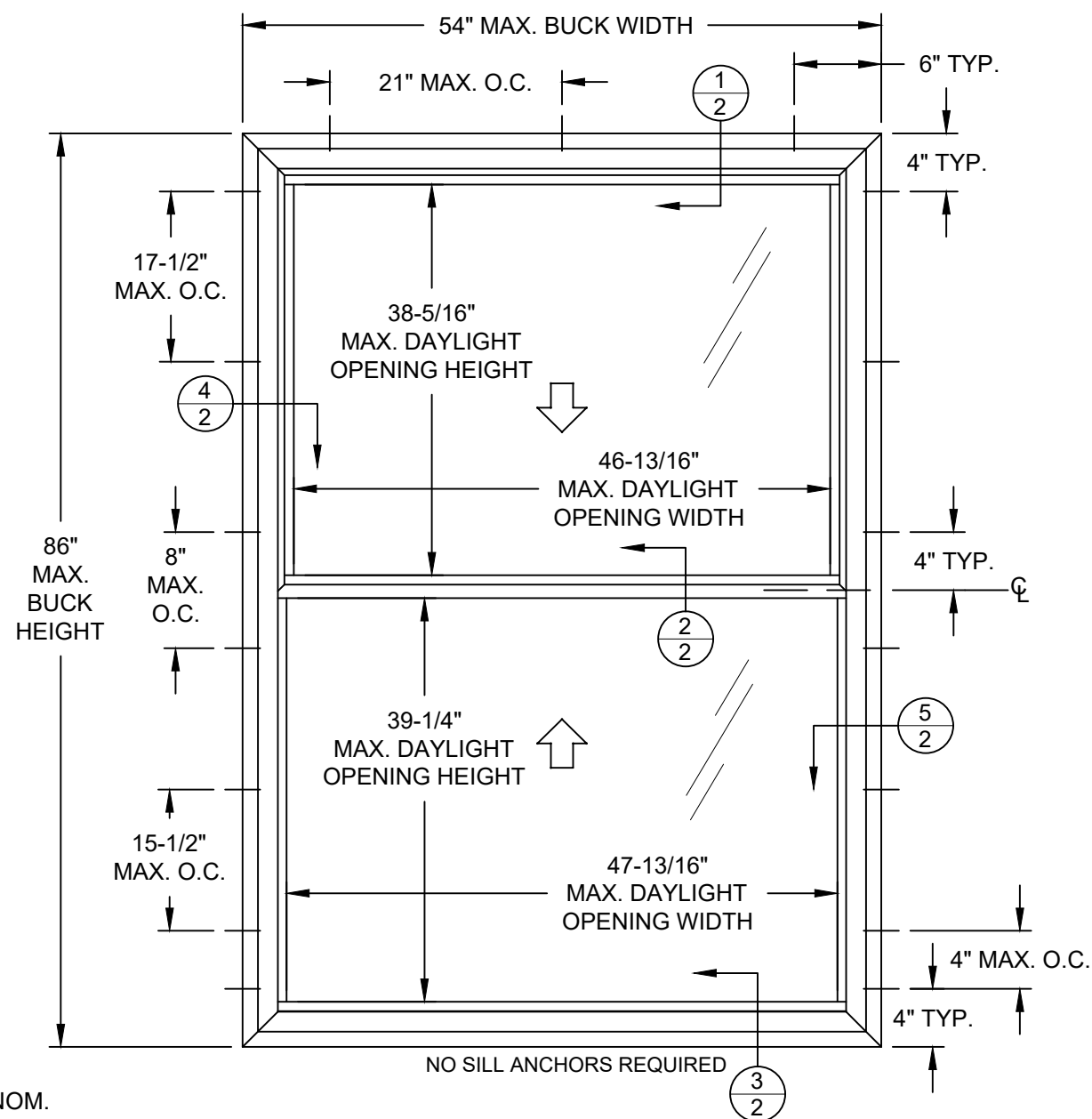

TYP. ANCHOR LOCATIONS @ TESTED SIZE
 (EQUAL LEG FRAME)

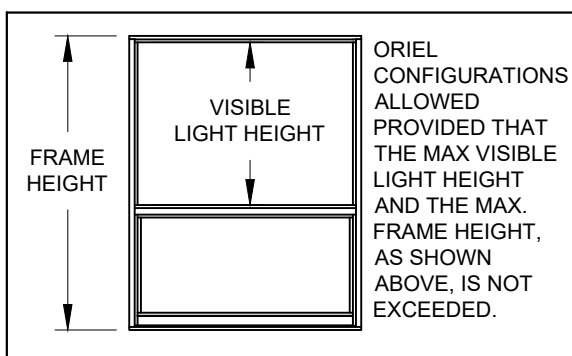
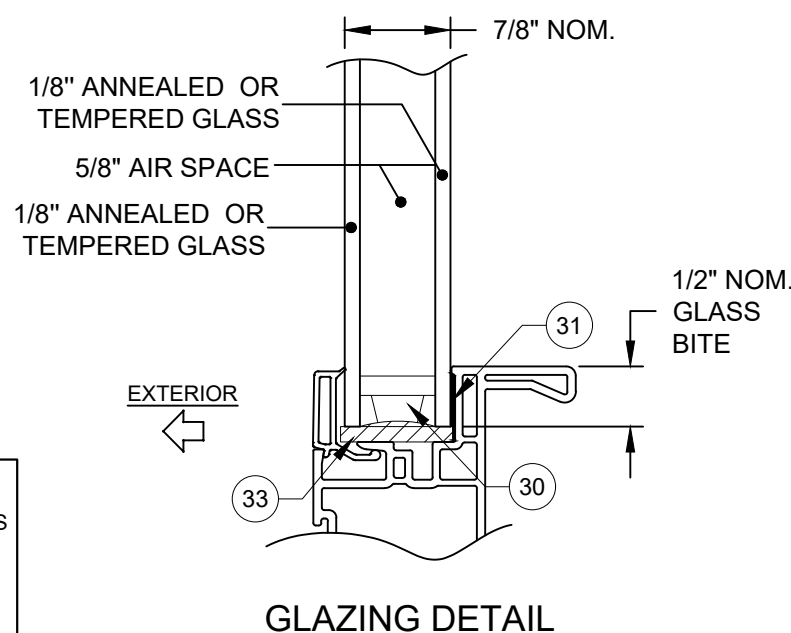
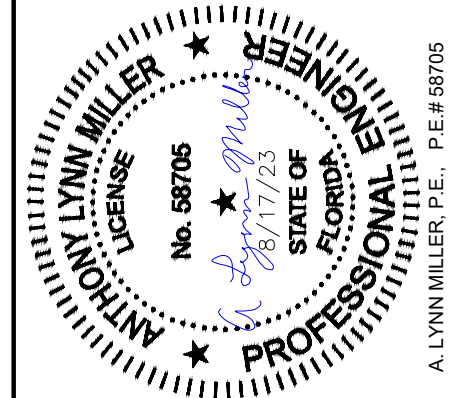

TABLE 1: DESIGN PRESSURES

Buck Width	Buck Height	Design Pressure	
		(+) psf	(-) psf
54"	76"	50.0	50.0
54"	86"	40.0	50.0

FOR SIZES NOT SHOWN, ROUND UP TO THE NEXT AVAILABLE WIDTH OR HEIGHT DIMENSION.



REGISTRATION #29296

COPYRIGHT © 2021
 NEWSOUTH WINDOW SOLUTIONS
 LIMITED LICENSE TO MAKE
 COPIES FOR PERMITTING

PREPARED BY: A. LYNN MILLER, P.E.
 1070 TECHNOLOGY DR
 N. VENICE, FL 34275
 (941)-480-1600

8400 SERIES DOUBLE HUNG
 GENERAL NOTES, DESIGN PRESSURES,
 GLAZING DETAILS & ANCHOR ELEVATION
 NEWSOUTH WINDOW SOLUTIONS
 10741 CROSSROADS COMMERCE BLVD.
 TAMPA, FL 33610

BY:	AM
REVISION:	ADD DOW 995
DATE:	8/23
#:	1
DATE:	05/24/21
SCALE:	NTS
BY:	JENS ROSOWSKI
DRAWING #:	DH8400-FPA-01
SHEET:	1 OF 4

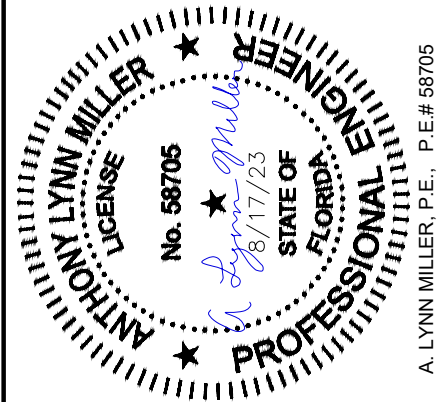

A. LYNN MILLER, P.E., P.E.# 58705

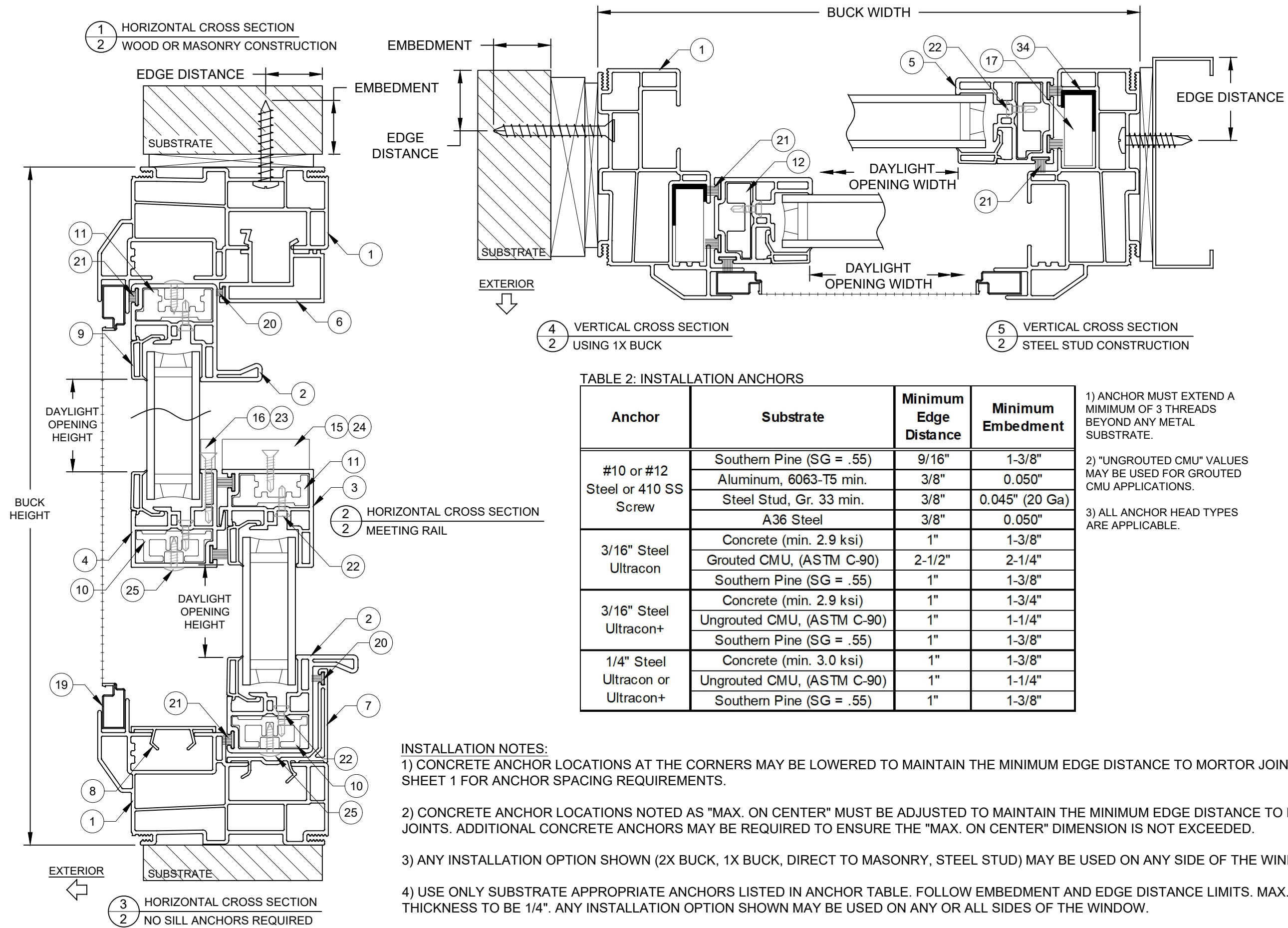

TABLE 2: INSTALLATION ANCHORS

Anchor	Substrate	Minimum Edge Distance	Minimum Embedment
#10 or #12 Steel or 410 SS Screw	Southern Pine (SG = .55)	9/16"	1-3/8"
	Aluminum, 6063-T5 min.	3/8"	0.050"
	Steel Stud, Gr. 33 min.	3/8"	0.045" (20 Ga)
	A36 Steel	3/8"	0.050"
3/16" Steel Ultracon	Concrete (min. 2.9 ksi)	1"	1-3/8"
	Grouted CMU, (ASTM C-90)	2-1/2"	2-1/4"
	Southern Pine (SG = .55)	1"	1-3/8"
3/16" Steel Ultracon+	Concrete (min. 2.9 ksi)	1"	1-3/4"
	UngROUTED CMU, (ASTM C-90)	1"	1-1/4"
	Southern Pine (SG = .55)	1"	1-3/8"
1/4" Steel Ultracon or Ultracon+	Concrete (min. 3.0 ksi)	1"	1-3/8"
	UngROUTED CMU, (ASTM C-90)	1"	1-1/4"
	Southern Pine (SG = .55)	1"	1-3/8"

- 1) ANCHOR MUST EXTEND A MINIMUM OF 3 THREADS BEYOND ANY METAL SUBSTRATE.
- 2) "UNGROUTED CMU" VALUES MAY BE USED FOR GROUDED CMU APPLICATIONS.
- 3) ALL ANCHOR HEAD TYPES ARE APPLICABLE.

INSTALLATION NOTES:

- 1) CONCRETE ANCHOR LOCATIONS AT THE CORNERS MAY BE LOWERED TO MAINTAIN THE MINIMUM EDGE DISTANCE TO MORTOR JOINTS. SEE SHEET 1 FOR ANCHOR SPACING REQUIREMENTS.
- 2) CONCRETE ANCHOR LOCATIONS NOTED AS "MAX. ON CENTER" MUST BE ADJUSTED TO MAINTAIN THE MINIMUM EDGE DISTANCE TO MORTOR JOINTS. ADDITIONAL CONCRETE ANCHORS MAY BE REQUIRED TO ENSURE THE "MAX. ON CENTER" DIMENSION IS NOT EXCEEDED.
- 3) ANY INSTALLATION OPTION SHOWN (2X BUCK, 1X BUCK, DIRECT TO MASONRY, STEEL STUD) MAY BE USED ON ANY SIDE OF THE WINDOW.
- 4) USE ONLY SUBSTRATE APPROPRIATE ANCHORS LISTED IN ANCHOR TABLE. FOLLOW EMBEDMENT AND EDGE DISTANCE LIMITS. MAX. SHIM THICKNESS TO BE 1/4". ANY INSTALLATION OPTION SHOWN MAY BE USED ON ANY OR ALL SIDES OF THE WINDOW.

REGISTRATION #29296

COPYRIGHT © 2021
NEWSOUTH WINDOW SOLUTIONS
LIMITED LICENSE TO MAKE
COPIES FOR PERMITTING

PREPARED BY: A. LYNN MILLER, P.E.
1070 TECHNOLOGY DR
N. VENICE, FL 34275
(941)-480-1600

8400 SERIES DOUBLE HUNG
INSTALLATION SECTION VIEWS
NEWSOUTH WINDOW SOLUTIONS
10741 CROSSROADS COMMERCE BLVD.
TAMPA, FL 33610

BY:	AM
REVISION:	ADD DOW 995
DATE:	8/23
#:	1
DATE:	05/24/21
SCALE:	NTS
BY:	JENS ROSOWSKI
DRAWING #:	DH8400-FPA-01
SHEET:	2 OF 4

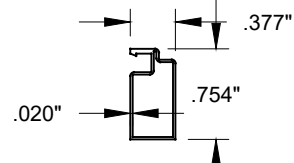
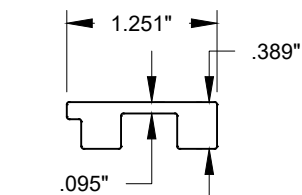
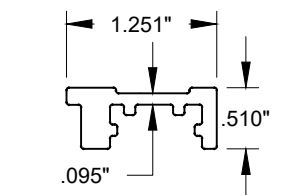
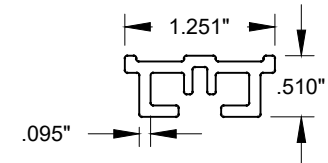
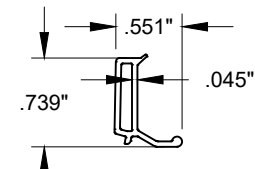
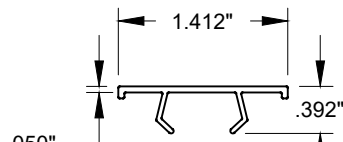
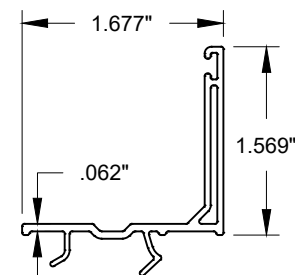
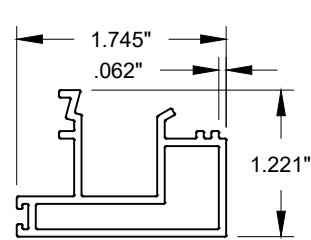
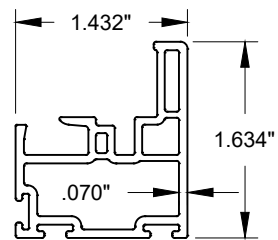
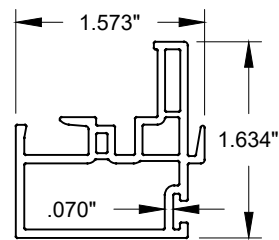
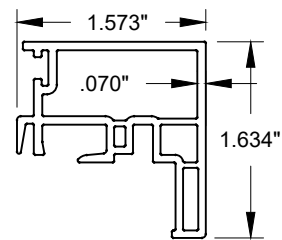
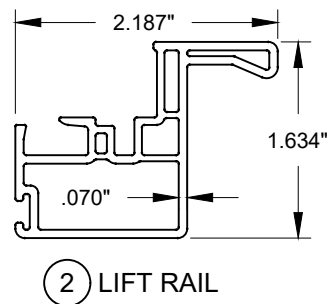
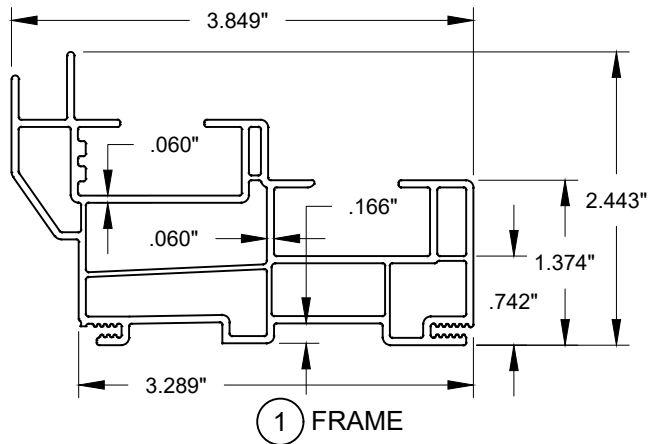

BILL OF MATERIALS

ITEM #	PART #	DESCRIPTION	MATERIAL
1	5443	FRAME	PVC
2	9485	LIFT RAIL (UPPER SASH TOP RAIL / LOWER SASH BTM RAIL)	PVC
3	9494	LOCK RAIL (LOWER SASH TOP RAIL)	PVC
4	9493	KEEPER RAIL (UPPER SASH BTM RAIL)	PVC
5	9438	SASH STILE	PVC
6	9474	HEAD ADAPTOR	PVC
7	9490	SILL ADAPTOR (RISER)	PVC
8	9473	SILL CAP	PVC
9	9425	GLAZING BEAD	PVC
10	6163	REINFORCEMENT (KEEPER RAIL / LOWER SASH BTM RAIL)	6061-T6
11	6165	REINFORCEMENT (LOCK RAIL / UPPER SASH TOP RAIL)	6061-T6
12	6164	REINFORCEMENT (SASH STILES)	6061-T6
13	8205/8206	TILT LATCH	STEEL
14	8148	PIVOT BAR	
15	8116	LOCK	ZINC
16	8096	KEEPER	ZINC
17		COIL BALANCER	
18	8223	WEEP COVER	NYLON
19	6244	SCREEN FRAME	ALUM
20	4003	WTSP, .187" x .270" POLYFIN	
21	4007	WTSP, .270" X .250" POLYFIN	
22		#6 x 1/2" PFH (REINFORCEMENT)	SS
23		#6 x 3/4" PFH (KEEPER)	SS
24		#6 x 1-1/4" PFH (LOCK)	SS
25		#8 x 1/2" PTRUSS	SS
30		IG SPACER	VARIES
31		SIKA 552 AND DOW 791/983/995 BACKBEDDING	SILICONE
33		SETTING BLOCK	
34	8244	JAMB REINFORCEMENT SUPPORT	STEEL
35	8223	WEEP COVER	

THE APPROVED WHITE, RIGID PVC EXTERIOR EXTRUSIONS FOR DOORS ARE TO BE PRODUCED BY EXTRUDERS' LICENSEES UNDER "AAMA CERTIFICATION PROGRAMS FOR RIGID PVC EXTRUSIONS".

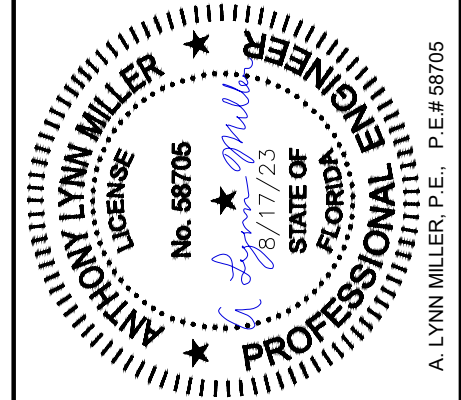

REGISTRATION #29296

COPYRIGHT © 2021
NEWSOUTH WINDOW SOLUTIONS
LIMITED LICENSE TO MAKE
COPIES FOR PERMITTING

PREPARED BY: A. LYNN MILLER, P.E.
1070 TECHNOLOGY DR
N. VENICE, FL 34275
(941)-480-1600

8400 SERIES DOUBLE HUNG
EXTRUSIONS & BOM
NEWSOUTH WINDOW SOLUTIONS
10741 CROSSROADS COMMERCE BLVD.
TAMPA, FL 33610

BY:	AM
REVISION:	ADD DOW 995
DATE:	8/23
#:	1

DATE: 05/24/21
SCALE: NTS
BY: JENS ROSOWSKI
DRAWING #: DH8400-FPA-01
SHEET: 3 OF 4

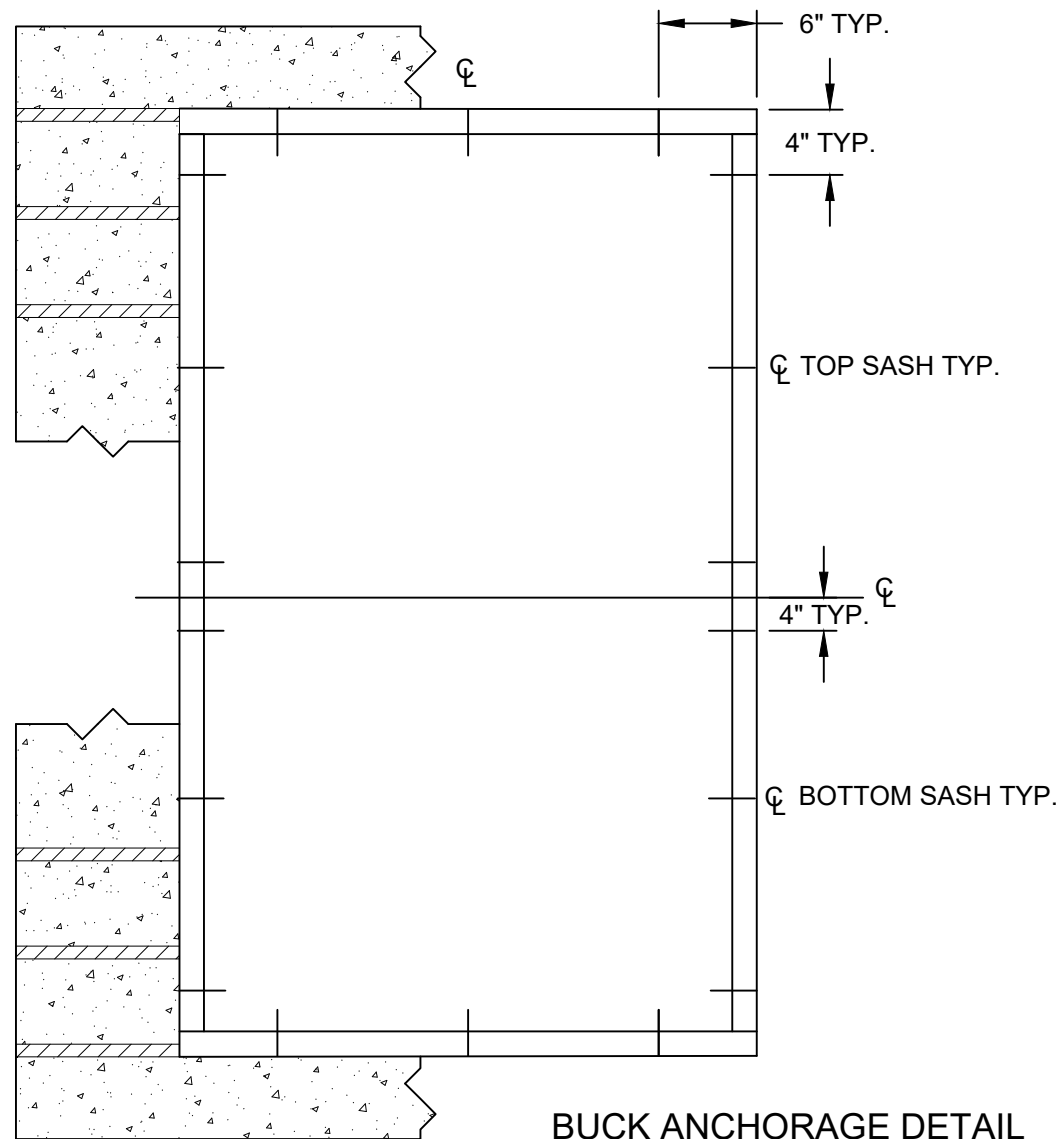

BUCK ANCHORAGE DETAIL

Anchor	Substrate	Minimum Edge Distance	Minimum Embedment
1/4" Steel Ultracon or Ultracon+	Concrete (min. 3.0 ksi)	1"	1-3/8"
	UngROUTED CMU, (ASTM C-90)	1"	1-1/4"

- 1) ANCHOR MUST EXTEND A MINIMUM OF 3 THREADS BEYOND ANY METAL SUBSTRATE.
- 2) FLATHEAD ANCHORS REQUIRED AT DOOR SILL. OTHER LOCATIONS MAY USE ANY HEAD TYPE.
- 3) MIN. #12 X 1" SMS TO BE USED FOR ALL MULLION APPLICATIONS.
- 4) FOR CASES WHERE SUBSTRATES VARY PER FRAME MEMBERS, USE THE HIGHEST ANCHOR GROUP LETTER FOR ALL SIDES.
- 5) "UNROUTED CMU" VALUES MAY BE USED FOR GROUDED CMU APPLICATIONS.
- 6) MASONRY ANCHOR LOCATIONS AT THE CORNERS MAY BE ADJUSTED TO MAINTAIN THE MINIMUM EDGE DISTANCE TO MORTOR JOINTS.
- 7) MASONRY ANCHOR LOCATIONS NOTED AS "MAX. ON CENTER" MUST BE ADJUSTED TO MAINTAIN THE MINIMUM EDGE DISTANCE TO MORTOR JOINTS. ADDITIONAL MASONRY ANCHORS MAY BE REQUIRED TO ENSURE THE "MAX. ON CENTER" DIMENSION IS NOT EXCEEDED.

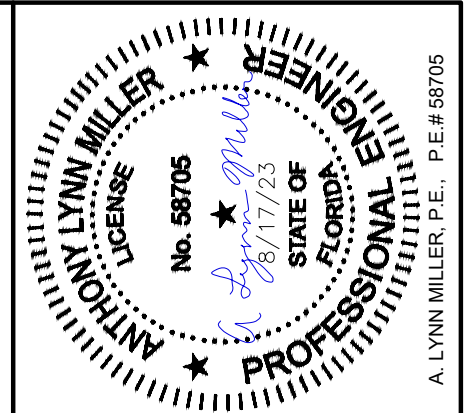

PREPARED BY: A. LYNN MILLER, P.E.
 1070 TECHNOLOGY DR
 N. VENICE, FL 34275
 (941)-480-1600

REGISTRATION #29296
 COPYRIGHT © 2021
 NEWSOUTH WINDOW SOLUTIONS
 LIMITED LICENSE TO MAKE
 COPIES FOR PERMITTING

BY: AM
 REVISION: ADD DOW 995
 DATE: 8/23
 # 1

8400 SERIES DOUBLE HUNG
 EXTRUSIONS & BOM
 NEWSOUTH WINDOW SOLUTIONS
 10741 CROSSROADS COMMERCE BLVD.
 TAMPA, FL 33610

DATE: 05/24/21
 SCALE: NTS
 BY: JENS ROSOWSKI
 DRAWING #: DH8400-FPA-01
 SHEET: 4 OF 4