

SINGLE HUNG ORIEL - NON-IMPACT

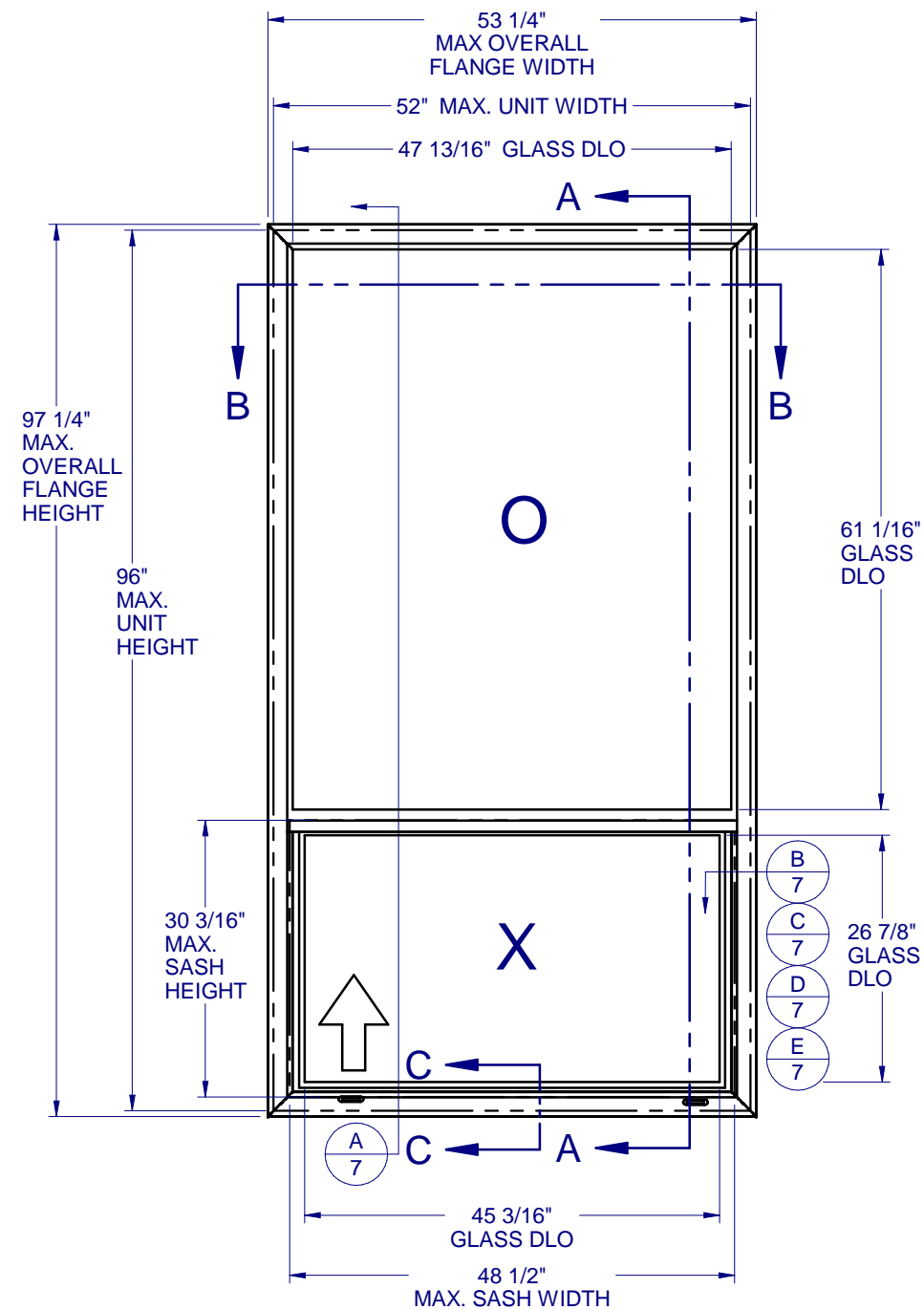

TABLE OF CONTENTS

GENERAL NOTES & ELEVATIONS.....	1
GLAZING DETAILS.....	2
COMPARATIVE ANALYSIS.....	3
SECTION VIEWS.....	4
BOM & EXTRUSIONS.....	5
ANCHOR SCHEDULE & NOTES.....	6
INSTALLATION DETAILS.....	7

CONFIG.	MAX. UNIT SIZE	DESIGN PRESSURE RATING	IMPACT RATING
ORIEL	52" x 96"	SEE COMPARATIVE ANALYSIS CHART, SHEET 3	NONE

GENERAL NOTES:

1. THE PRODUCT SHOWN HEREIN IS DESIGNED AND MANUFACTURED TO COMPLY WITH THE FLORIDA BUILDING CODE (FBC), CURRENT EDITION.
2. GLAZING OPTIONS: (SEE SHEET 2)
3. CONFIGURATIONS: "O/X".
4. DESIGN PRESSURE RATING (SEE SHEET 3):
 -NEGATIVE DESIGN LOADS BASED ON, TESTED PRESSURE AND GLASS TABLES ASTM E-1300-04e01/09.
 -POSITIVE DESIGN LOADS BASED ON, TESTED PRESSURE, WATER INFILTRATION TEST PRESSURE AND GLASS TABLES ASTM E-1300-04E01/09.
5. ANCHORAGE: THE 33 1/3% STRESS INCREASE HAS NOT BEEN USED IN THE DESIGN OF THIS PRODUCT. SEE SHEET 7 FOR ANCHOR DETAILS. WINDLOAD DURATION FACTOR Cd=1.6 WAS USED FOR WOOD ANCHOR CALCULATIONS.
6. NOT APPROVED FOR IMPACT RESISTANCE. IMPACT PROTECTIVE SYSTEM IS REQUIRED IN WIND BORNE DEBRIS REGION.
7. ALL FRAMES AND VENTS FULLY WELDED. SMALL JOINT SEAM SEALANT USED AT FIXED MEETING RAIL AND JAMB.
8. SERIES / MODEL DESIGNATION SH-8100.
9. THE DESIGNATION X AND O STAND FOR THE FOLLOWING:
 X = OPERABLE SASH, O = FIXED SASH
10. SECTION CALLOUTS APPLY TO ALL ELEVATIONS IN A SIMILAR LOCATION.
11. EXTERNAL WEEP SLOT = 1/2" x 2-1/2" LOCATED 4" FROM BOTH ENDS.



510 PVC SINGLE HUNG NON-IMPACT

PROPRIETARY AND CONFIDENTIAL
 THE INFORMATION CONTAINED IN THIS DRAWING IS THE SOLE PROPERTY OF CUSTOM WINDOW SYSTEMS, INC. ANY REPRODUCTION IN PART OR AS A WHOLE WITHOUT THE WRITTEN PERMISSION OF CUSTOM WINDOW SYSTEMS, INC IS PROHIBITED.

FLORIDA APPROVAL NO.:
33447



9/26/2023

LUCAS A. TURNER, P.E.
 FL PE # 58201
 Turner Engineering & Consulting, Inc.
 2428 Old Natchez Trc Trl
 Camden, TN 38320
 PH. 941-380-1574

SHEET DESCRIPTION:
GENERAL NOTES AND ELEVATIONS

DRAWN BY: MCS	DATE: 9/19/2023
DWG #: PEL-293	REV.: B
SCALE: 1:20	SHEET 1 OF 7

**510 PVC
 SINGLE HUNG
 NON-IMPACT**

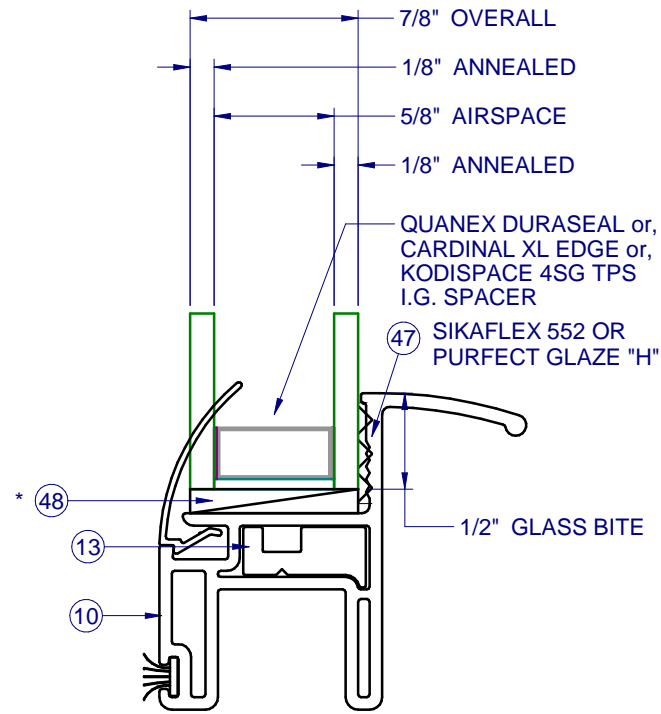

GLASS TYPE A

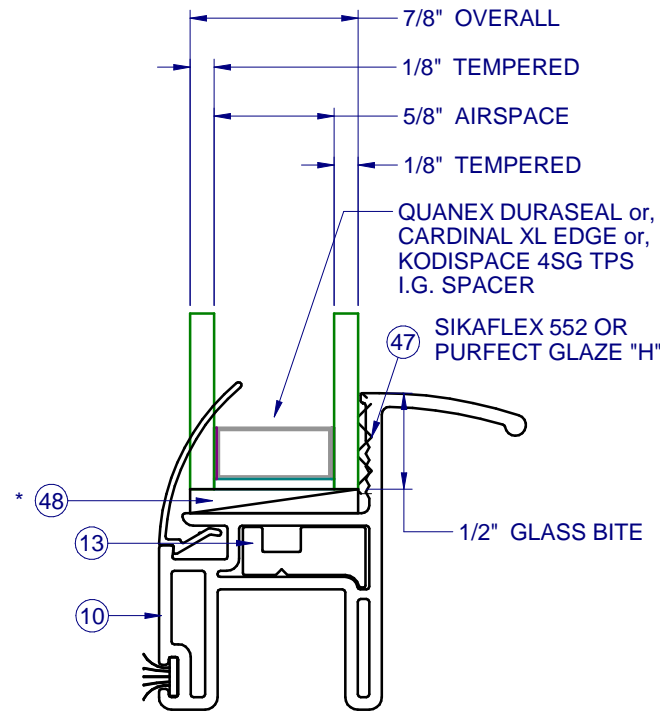

GLASS TYPE B

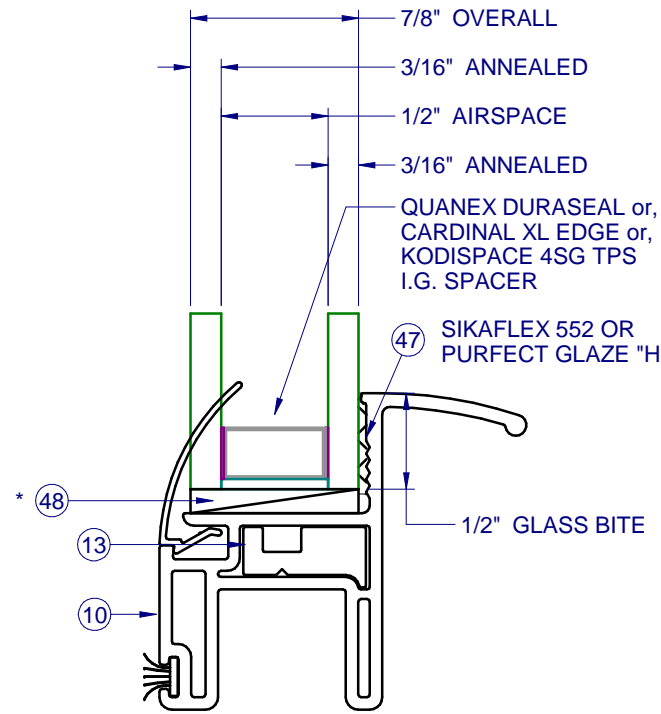

GLASS TYPE C

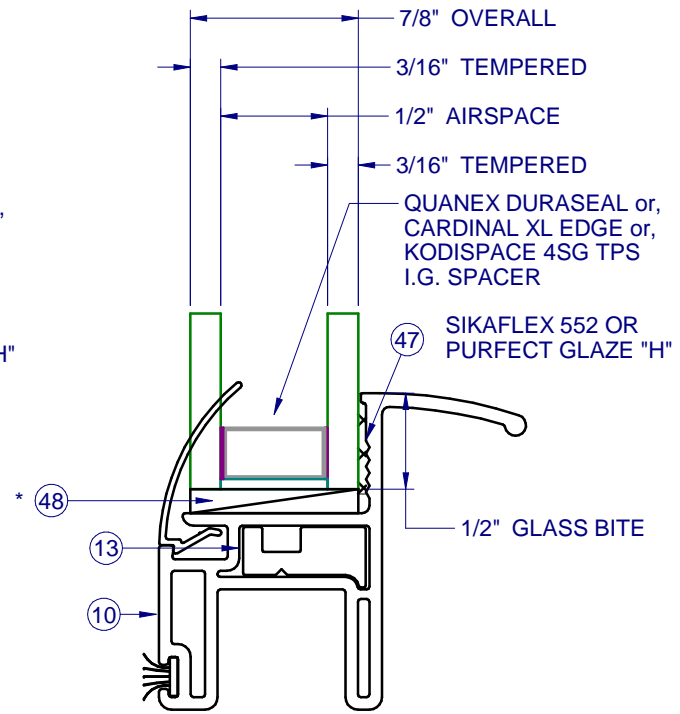

GLASS TYPE D

PROPRIETARY AND CONFIDENTIAL
 THE INFORMATION CONTAINED IN THIS DRAWING IS THE SOLE PROPERTY OF CUSTOM WINDOW SYSTEMS, INC. ANY REPRODUCTION IN PART OR AS A WHOLE WITHOUT THE WRITTEN PERMISSION OF CUSTOM WINDOW SYSTEMS, INC IS PROHIBITED.

FLORIDA APPROVAL NO.:
 33447

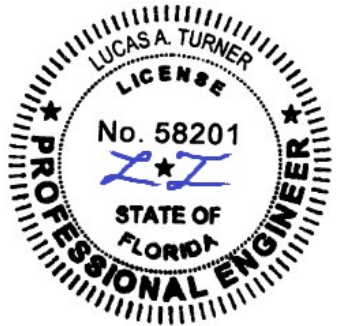

9/26/2023

LUCAS A. TURNER, P.E.
 FL PE # 58201
 Turner Engineering & Consulting, Inc.
 2428 Old Natchez Trc Trl
 Camden, TN 38320
 PH. 941-380-1574

SHEET DESCRIPTION:

GLAZING DETAILS

DRAWN BY: MCS	DATE: 9/19/2023
DWG #: PEL-293	REV.: B
SCALE: 1:1	SHEET 2 OF 7

Design Pressures (PSF) for Fin or Flange Oriel Configuration with Sash Glass Type A, B, C, or D, & Fixed Glass Type as Indicated in Chart

Unit Height (in.)	Sash Height (in.)	Fixed Glass Type	Unit Widths (in.)									
			23 1/2	27 1/2	29 1/2	31 1/2	35 1/2	39 1/2	41 1/2	43 1/2	47 1/2	52
27 1/2	12	A	+60 / -90	+60 / -90	+60 / -90	+60 / -90	+60 / -90	+60 / -90	+60 / -90	+60 / -90	+60 / -90	+60 / -90
		B, C, or D	+60 / -90	+60 / -90	+60 / -90	+60 / -90	+60 / -90	+60 / -90	+60 / -90	+60 / -90	+60 / -90	+60 / -90
29 1/2	12	A	+60 / -90	+60 / -90	+60 / -90	+60 / -90	+60 / -90	+60 / -90	+60 / -90	+60 / -90	+60 / -90	+60 / -90
		B, C, or D	+60 / -90	+60 / -90	+60 / -90	+60 / -90	+60 / -90	+60 / -90	+60 / -90	+60 / -90	+60 / -90	+60 / -90
35 1/2	12	A	+60 / -90	+60 / -90	+60 / -90	+60 / -90	+60 / -90	+60 / -90	+60 / -90	+60 / -90	+60 / -89.5	+60 / -79.8
		B, C, or D	+60 / -90	+60 / -90	+60 / -90	+60 / -90	+60 / -90	+60 / -90	+60 / -90	+60 / -90	+60 / -90	+60 / -90
41 1/2	13 3/16	A	+60 / -90	+60 / -90	+60 / -90	+60 / -90	+60 / -90	+60 / -90	+60 / -90	+60 / -90	+60 / -87.1	+60 / -75.8
		B, C, or D	+60 / -90	+60 / -90	+60 / -90	+60 / -90	+60 / -90	+60 / -90	+60 / -90	+60 / -90	+60 / -90	+60 / -88.8
47 1/2	15 1/16	A	+60 / -90	+60 / -90	+60 / -90	+60 / -90	+60 / -90	+60 / -90	+60 / -90	+60 / -90	+60 / -84.3	+60 / -74.9
		B, C, or D	+60 / -90	+60 / -90	+60 / -90	+60 / -90	+60 / -90	+60 / -90	+60 / -90	+60 / -90	+60 / -90	+60 / -81
53 1/2	16 15/16	A	+60 / -90	+60 / -90	+60 / -90	+60 / -90	+60 / -90	+60 / -90	+60 / -88.5	+60 / -84.7	+60 / -77.4	+60 / -71.2
		B, C, or D	+60 / -90	+60 / -90	+60 / -90	+60 / -90	+60 / -90	+60 / -90	+60 / -90	+60 / -90	+60 / -85.7	+60 / -75.3
59 1/2	18 7/8	A	+60 / -90	+60 / -90	+60 / -90	+60 / -90	+60 / -90	+60 / -84.3	+60 / -80.5	+60 / -76.2	+60 / -70.9	+60 / -65.2
		B, C, or D	+60 / -90	+60 / -90	+60 / -90	+60 / -90	+60 / -90	+60 / -90	+60 / -90	+60 / -90	+60 / -81.4	+60 / -70.9
63 1/2	20 1/8	A	+60 / -90	+60 / -90	+60 / -90	+60 / -90	+60 / -87.1	+60 / -78.7	+60 / -75	+60 / -72.1	+60 / -66.9	+60 / -61.2
		B, C, or D	+60 / -90	+60 / -90	+60 / -90	+60 / -90	+60 / -90	+60 / -90	+60 / -90	+60 / -90	+60 / -79.2	+60 / -68.7
65 1/2	20 3/4	A	+60 / -90	+60 / -90	+60 / -90	+60 / -90	+60 / -84.4	+60 / -76.2	+60 / -73	+60 / -70.3	+60 / -65	+59.1 / -59.1
		B, C, or D	+60 / -90	+60 / -90	+60 / -90	+60 / -90	+60 / -90	+60 / -90	+60 / -90	+60 / -90	+60 / -78.3	+60 / -67.7
67 1/2	21 3/8	A	+60 / -90	+60 / -90	+60 / -89.3	+60 / -87.9	+60 / -81.4	+60 / -74	+60 / -71	+60 / -68.2	+60 / -63.1	+57 / -57
		B, C, or D	+60 / -90	+60 / -90	+60 / -90	+60 / -90	+60 / -90	+60 / -90	+60 / -90	+60 / -90	+60 / -77.4	+60 / -66.8
71 1/2	22 11/16	A	+60 / -86.7	+60 / -84	+60 / -83.7	+60 / -82.2	+60 / -77	+60 / -71	+60 / -68	+60 / -65	+59.3 / -59.3	+54 / -54
		B, C, or D	+60 / -90	+60 / -90	+60 / -90	+60 / -90	+60 / -90	+60 / -90	+60 / -90	+60 / -90	+60 / -88.5	+60 / -76.1
74 3/4	23 11/16	A	+60 / -82.2	+60 / -78.6	+60 / -78.5	+60 / -78	+60 / -73.9	+60 / -68.3	+60 / -65.5	+60 / -62.4	+56.6 / -56.6	+51.8 / -51.8
		B, C, or D	+60 / -90	+60 / -90	+60 / -90	+60 / -90	+60 / -90	+60 / -90	+60 / -90	+60 / -90	+60 / -87.4	+60 / -75.2
81 1/2	25 13/16	A	+60 / -73.8	+60 / -69.3	+60 / -69.5	+60 / -69.4	+60 / -67.1	+60 / -62.4	+59.3 / -59.3	+56.4 / -56.4	+52 / -52	+47.2 / -47.2
		B, C, or D	+60 / -83.9	+60 / -83.2	+60 / -83.2	+60 / -83.2	+60 / -83.2	+60 / -83.2	+60 / -83.2	+60 / -83.2	+60 / -83.2	+60 / -73.4
86 3/4	27 1/2	A	+60 / -70.1	+60 / -63.2	+60 / -63.4	+60 / -63.8	+60 / -62.7	+58.1 / -58.1	+55.6 / -55.6	+53.3 / -53.3	+49 / -49	+44.6 / -44.6
		B, C, or D	+60 / -75.1	+60 / -73.5	+60 / -73.5	+60 / -73.5	+60 / -73.5	+60 / -73.5	+60 / -73.5	+60 / -73.5	+60 / -73.5	+60 / -72.1
96	30 7/16	A	+60 / -63.3	+54.2 / -54.2	+53.7 / -53.7	+54.1 / -54.1	+54.7 / -54.7	+52.7 / -52.7	+50.7 / -50.7	+48.6 / -48.6	+44.8 / -44.8	+40.9 / -40.9
		B, C, or D	+60 / -63.3	+60 / -60.6	+60 / -60.1	+60 / -60	+60 / -60	+60 / -60	+60 / -60	+60 / -60	+60 / -60	+60 / -60

NOTE: IF SIZE INTENDED IS NOT SHOWN, USE NEXT LARGER SIZE.



**510 PVC
SINGLE HUNG
NON-IMPACT**

PROPRIETARY AND CONFIDENTIAL
THE INFORMATION CONTAINED IN THIS DRAWING IS THE SOLE PROPERTY OF CUSTOM WINDOW SYSTEMS, INC. ANY REPRODUCTION IN PART OR AS A WHOLE WITHOUT THE WRITTEN PERMISSION OF CUSTOM WINDOW SYSTEMS, INC IS PROHIBITED.

FLORIDA APPROVAL NO.:
33447

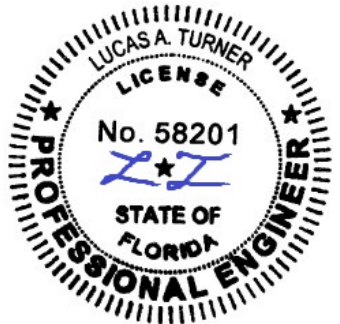

9/26/2023

LUCAS A. TURNER, P.E.
FL PE # 58201
Turner Engineering & Consulting, Inc.
2428 Old Natchez Trc Trl
Camden, TN 38320
PH. 941-380-1574

SHEET DESCRIPTION:

COMPARATIVE ANALYSIS

DRAWN BY: MCS	DATE: 9/19/2023
DWG #: PEL-293	REV.: B
SCALE: 1:1	SHEET 3 OF 7

**510 PVC
 SINGLE HUNG
 NON-IMPACT**

PROPRIETARY AND CONFIDENTIAL
 THE INFORMATION CONTAINED IN
 THIS DRAWING IS THE SOLE
 PROPERTY OF CUSTOM WINDOW
 SYSTEMS, INC. ANY
 REPRODUCTION IN PART OR AS A
 WHOLE WITHOUT THE WRITTEN
 PERMISSION OF CUSTOM WINDOW
 SYSTEMS, INC IS PROHIBITED.

FLORIDA APPROVAL NO.:
 33447

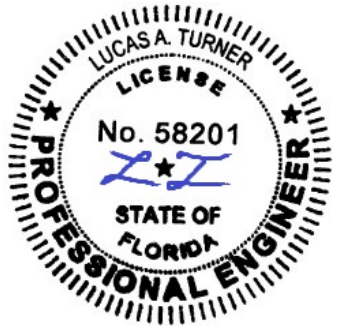

9/26/2023

LUCAS A. TURNER, P.E.
 FL PE # 58201
 Turner Engineering &
 Consulting, Inc.
 2428 Old Natchez Trc Trl
 Camden, TN 38320
 PH. 941-380-1574

SHEET DESCRIPTION:

SECTION VIEWS

DRAWN BY: MCS	DATE: 9/19/2023
DWG #: PEL-293	REV.: B
SCALE: 1:2	SHEET 4 OF 7

INTERIOR

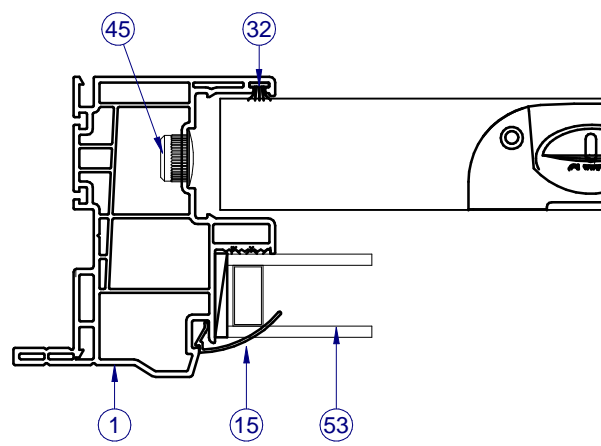
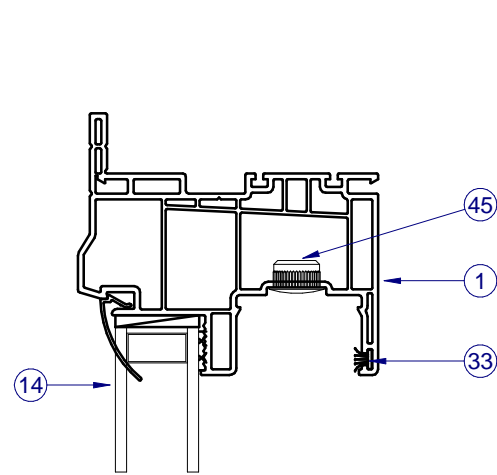

SECTION B-B

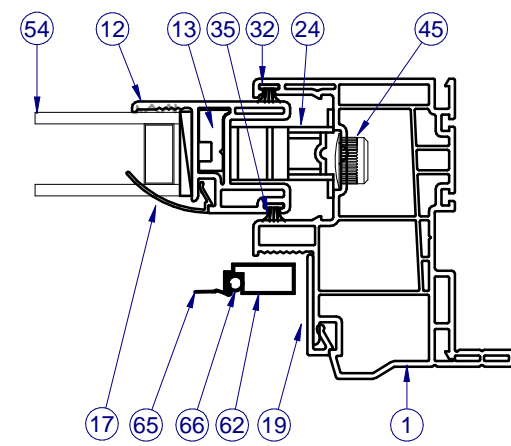

NOTE: LEFT SIDE SHOWS FIXED SECTION VIEW,
 RIGHT SIDE SHOWS SASH SECTION VIEW.

INTERIOR

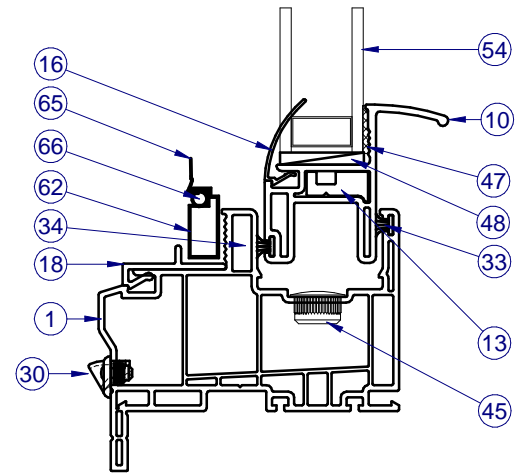
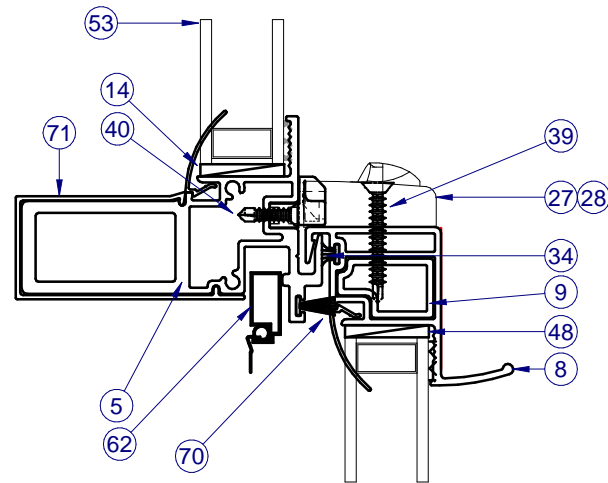

SECTION A-A

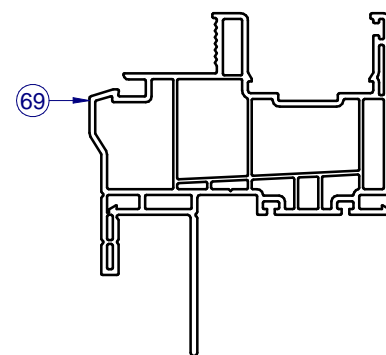

SECTION C-C
 ALTERNATE FIN FRAME

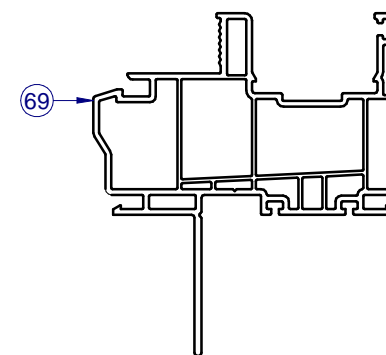

SECTION C-C
 ALTERNATE FIN ONLY FRAME

NOTE: ITEMS NOT SHOWN FOR CLARITY:
 20, 25-26, 31, 36-37, 44, 51-52, 55-56, 64, 67-68

PARTS LIST

Item	Part #	Description	Material
1	H-6222	Main Fr., SH, w/Flg., PVC	PVC
5	H-2122	Heavy Duty, Meet. Rail, Fxd. Aluminum	Alum
8	H-6224	Sash Meet. Rail, PVC	PVC
9	H-2124	Reinf. Sash Meet. Rail	Alum
10	H-6223	Sash Bottom Rail, PVC	PVC
12	H-6225	Sash Side/Top/Bot. Rail	PVC
13	S-2129	Reinf. S.B.R./S.S.R	Alum
14	S-6237	Glz. Bd., 7/8", Fxd.	PVC
18	S-6226	Scr. Adapt., w/Nib, PVC, Horiz.	PVC
19	S-6227	Scr. Adapt., PVC, Vert.	PVC
20	S-6025	Sash Stop / Filler, PVC, Vert.	PVC
24		SASH BALANCE	
25	P-4056	SASH CAM FOR PVC WINDOW	Plastic
26	P-3295	Take Out Clip	SS
27	P-3783	Lock, Impact, PVC	
28	P-4069	Keeper, Impact, PVC	Zamac
30	P-4479	WEEP HOLE COVER	Plastic
32	P-3305	Wstp., .270 x .187 High Density	
37	P-4638	#8x2 1/2" Ph Modified Truss Type A TEK2	Steel
38	P-3541	#8x1/2" Quadrex PH TEK	Steel
39	P-4051W	#8 x 1.250 Ph FH TEK, Wht.	Steel
40	P-3539	#8 x 3/4" Phillips Square SMS	Steel
44	P-3342	Seam Sealer, SM-5504	
45	P-5588	Cap Plug, 1/2" Hole	Nylon
47		Sikaflex 552 or Purfect Glaze "H"	
48	P-5612	Setting Block, .12 x 1 x 2	Rubber
53		Glass, Fixed (See Sheet 2)	
54		Glass, Sash (See Sheet 2)	
62	P-3218	Screen Frame	Alum
64	P-4754	SCREEN CORNER KEY	Plastic
65	P-4770	30" BetterVue Insect Screen 18x16	Fiberglass
66	P-5576	Screen Spline, .125" Black PE Ribbed	PVC
67	P-4755	SCREEN CORNER KEY	Alum
68	P-3033	Screen Spring, SS	SS
69	H-6231	Main Fr., SH, w/Fin., PVC	
70	P-4959	Wstp., 0.420 x .187 back FinSeal, Gray	Nylon
71	S-6229	Cover, HD Meeting Rail	PVC

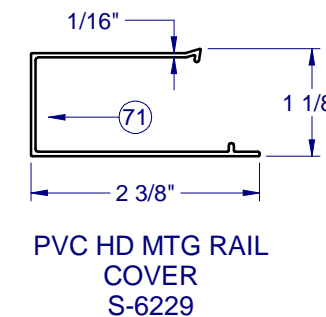
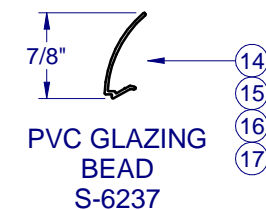
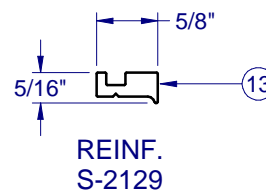
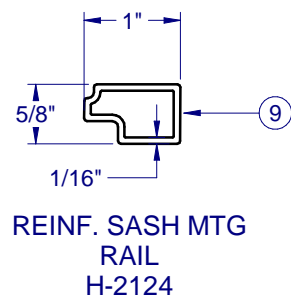
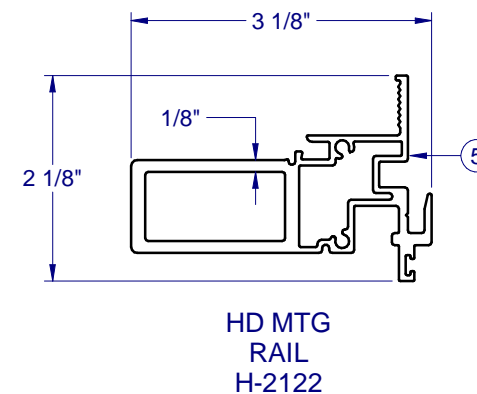
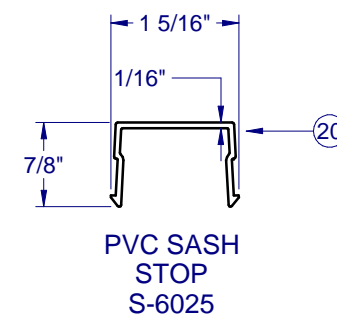
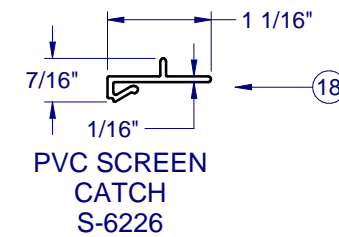
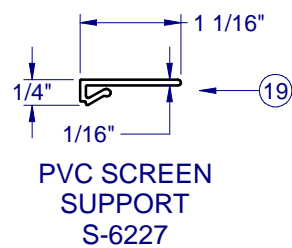
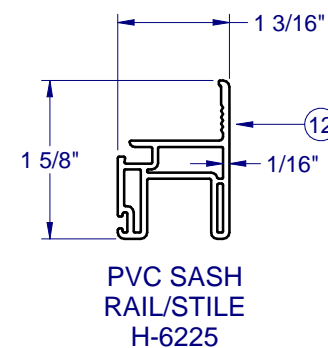
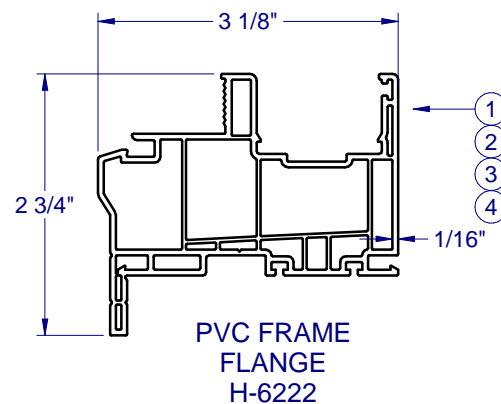
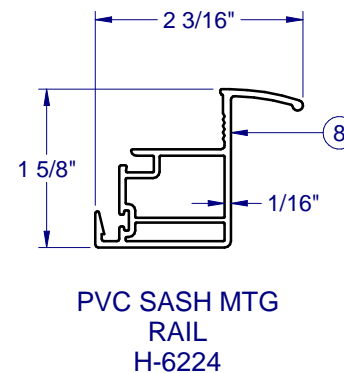
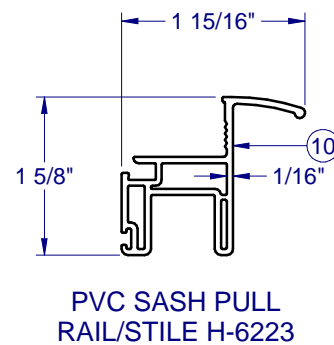
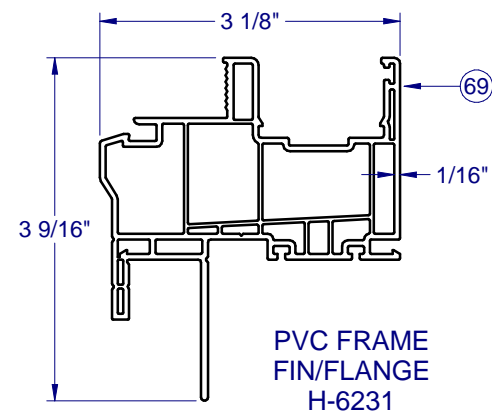

FRAME CORNER CONSTRUCTION

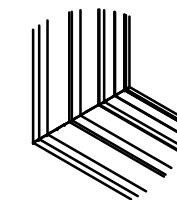

CORNER WELD (ALL SIDES) 1:8

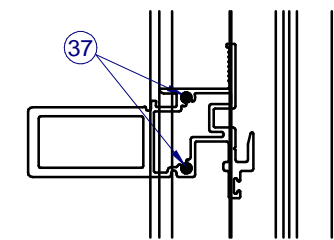

FIXED MEETING RAIL SCREWED TOGETHER WITH OUTERFRAME 1:8



Pella Corporation
102 Main Street
Pella, IA 50219
www.pella.com

510 PVC SINGLE HUNG NON-IMPACT

PROPRIETARY AND CONFIDENTIAL
THE INFORMATION CONTAINED IN THIS DRAWING IS THE SOLE PROPERTY OF CUSTOM WINDOW SYSTEMS, INC. ANY REPRODUCTION IN PART OR AS A WHOLE WITHOUT THE WRITTEN PERMISSION OF CUSTOM WINDOW SYSTEMS, INC IS PROHIBITED.

FLORIDA APPROVAL NO.: 33447

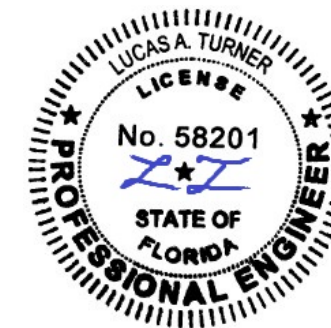

9/26/2023

LUCAS A. TURNER, P.E.
FL PE # 58201
Turner Engineering & Consulting, Inc.
2428 Old Natchez Trc Trl
Camden, TN 38320
PH. 941-380-1574

SHEET DESCRIPTION:

BOM AND EXTRUSIONS

DRAWN BY:	DATE:
MCS	9/19/2023
DWG #:	REV.:
PEL-293	B
SCALE:	SHEET
1:2	5 OF 7

LINE ITEMS NOT USED:
6-7, 21-22, 29, 31, 41-43, 46, 49-50, 55-61

NOTE: ALL ALUMINUM EXTRUSIONS ARE 6063-T6 UNLESS OTHERWISE NOTED.

**510 PVC
 SINGLE HUNG
 NON-IMPACT**

PROPRIETARY AND CONFIDENTIAL
 THE INFORMATION CONTAINED IN
 THIS DRAWING IS THE SOLE
 PROPERTY OF CUSTOM WINDOW
 SYSTEMS, INC. ANY
 REPRODUCTION IN PART OR AS A
 WHOLE WITHOUT THE WRITTEN
 PERMISSION OF CUSTOM WINDOW
 SYSTEMS, INC IS PROHIBITED.

FLORIDA APPROVAL NO.:
 33447

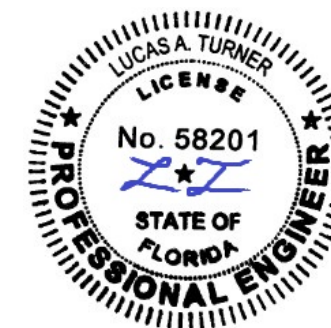

9/26/2023

LUCAS A. TURNER, P.E.
 FL PE # 58201
 Turner Engineering &
 Consulting, Inc.
 2428 Old Natchez Trc Trl
 Camden, TN 38320
 PH. 941-380-1574

SHEET DESCRIPTION:
**ANCHOR SCHEDULE AND
 NOTES**

DRAWN BY:	DATE:
MCS	9/19/2023
DWG #:	REV.:
PEL-293	B
SCALE:	SHEET
1:25	6 OF 7

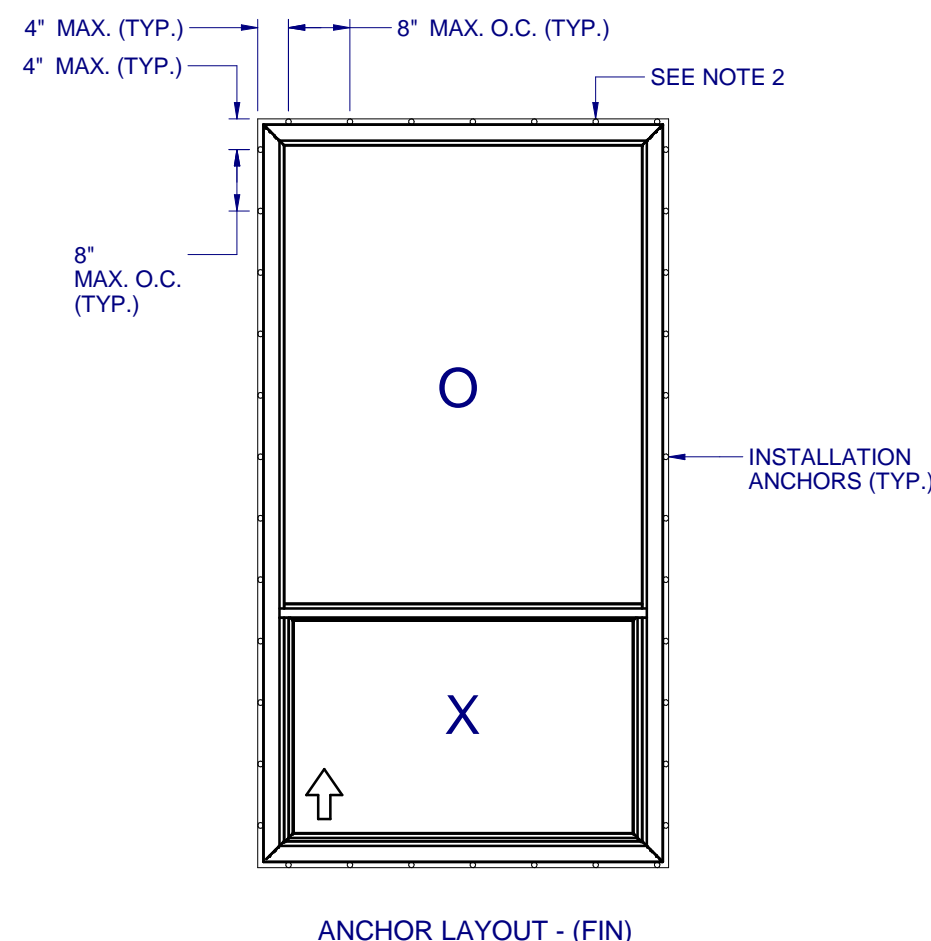
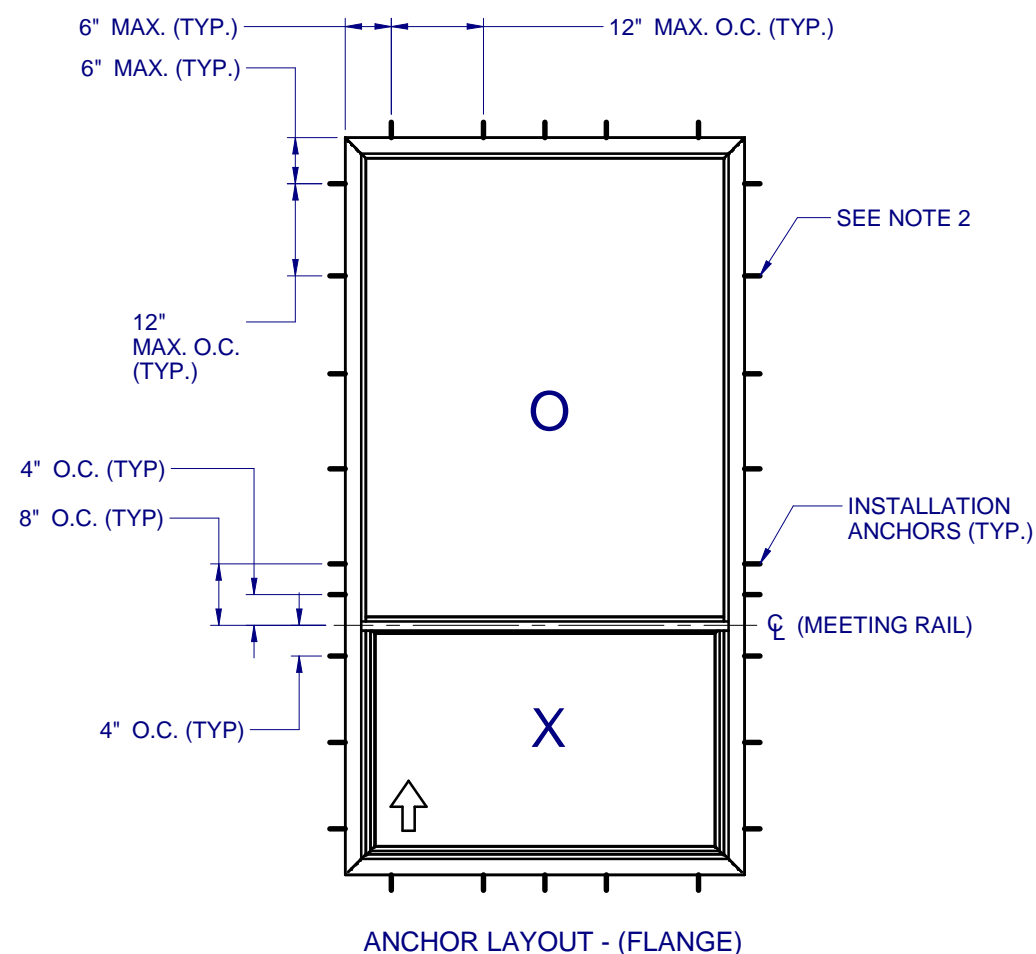

NOTES:

1. INSTALL ONE ANCHOR AT EACH INSTALLATION LOCATION. SILL ANCHOR SPACING SAME AS HEAD.
2. SHIM AS REQ AT EACH INSTALLATION ANCHOR USING LOAD BEARING SHIMS. MAX. ALLOWABLE SHIM STACK TO BE 1/4". USE SHIMS WHERE SPACE GREATER THAN 1/16" IS PRESENT. LOAD BEARING SHIMS SHALL BE CONSTRUCTED OF HIGH DENSITY PLASTIC OR BETTER. WOOD SHIMS ARE NOT ALLOWED.
3. ANCHOR TYPE, SIZE, SPACING AND EMBEDMENT SHALL BE AS SPECIFIED IN THESE DRAWINGS, SEE TABLE 1, SHEET 7.
4. ALL INSTALLATION ANCHORS MUST BE MADE OF OR PROTECTED WITH A CORROSION RESISTANT MATERIAL OR COATING. DISSIMILAR METALS OR MATERIALS IN CONTACT WITH PRESSURE TREATED WOOD MUST BE PROTECTED TO PREVENT REACTION.
5. INSTALLATION ANCHORS SHALL BE IN ACCORDANCE WITH ANCHOR MANUFACTURER'S INSTALLATION INSTRUCTIONS, AND ANCHORS SHALL NOT BE USED IN SUBSTRATES WITH STRENGTHS LESS THAN THE MINIMUM SPECIFIED IN TABLE 1, SHEET 7.
6. ANCHOR EMBEDMENT TO SUBSTRATE SHALL BE BEYOND WALL DRESSING OR STUCCO. FOR CONCRETE/CMU OPENINGS, EMBEDMENT SHALL BE BEYOND WOOD BUCKS, IF USED, INTO SUBSTRATE - 1X BUCKS ARE OPTIONAL.
7. A MINIMUM CENTER-TO-CENTER SPACING SHALL BE MAINTAINED BETWEEN ALL FASTENERS: 3" FOR MASONRY, 1" FOR WOOD AND METAL.
8. WOOD OR MASONRY OPENINGS, BUCKS AND BUCK FASTENERS SHALL BE PROPERLY DESIGNED BY THE ARCHITECT OR ENGINEER OF RECORD AND INSTALLED TO TRANSFER WIND LOADS TO THE STRUCTURE. SUBSTRATES SHALL MEET THE MINIMUM STRENGTH REQUIREMENTS AS SHOWN IN TABLE 1, SHEET 7. CONCRETE AND MASONRY SUBSTRATES MAY NOT BE CRACKED.
9. SEALING AND FLASHING STRATEGIES FOR OVERALL WATER RESISTANCE OF INSTALLATION SHALL BE DONE BY OTHERS FOLLOWING THE CURRENT VERSION OF THE REFERENCE DOCUMENTS: FMA/AAMA 100(FIN WINDOWS), FMA/AAMA 200(FLANGE WINDOWS), FMA/WDMA 250(BOX WINDOWS), FMA/AAMA/WDMA 300(EXTERIOR DOORS)

**510 PVC
 SINGLE HUNG
 NON-IMPACT**

PROPRIETARY AND CONFIDENTIAL
 THE INFORMATION CONTAINED IN
 THIS DRAWING IS THE SOLE
 PROPERTY OF CUSTOM WINDOW
 SYSTEMS, INC. ANY
 REPRODUCTION IN PART OR AS A
 WHOLE WITHOUT THE WRITTEN
 PERMISSION OF CUSTOM WINDOW
 SYSTEMS, INC IS PROHIBITED.

FLORIDA APPROVAL NO.:
 33447

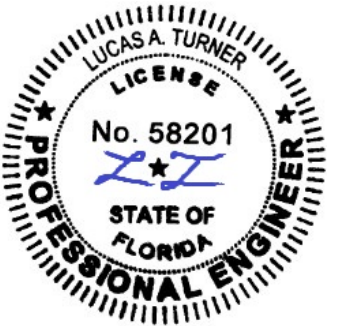

9/26/2023

LUCAS A. TURNER, P.E.
 FL PE # 58201
 Turner Engineering &
 Consulting, Inc.
 2428 Old Natchez Trc Trl
 Camden, TN 38320
 PH. 941-380-1574

SHEET DESCRIPTION:

INSTALLATION DETAILS

DRAWN BY:	DATE:
MCS	9/19/2023
DWG #:	REV.:
PEL-293	B
SCALE:	SHEET
1:2	7 OF 7

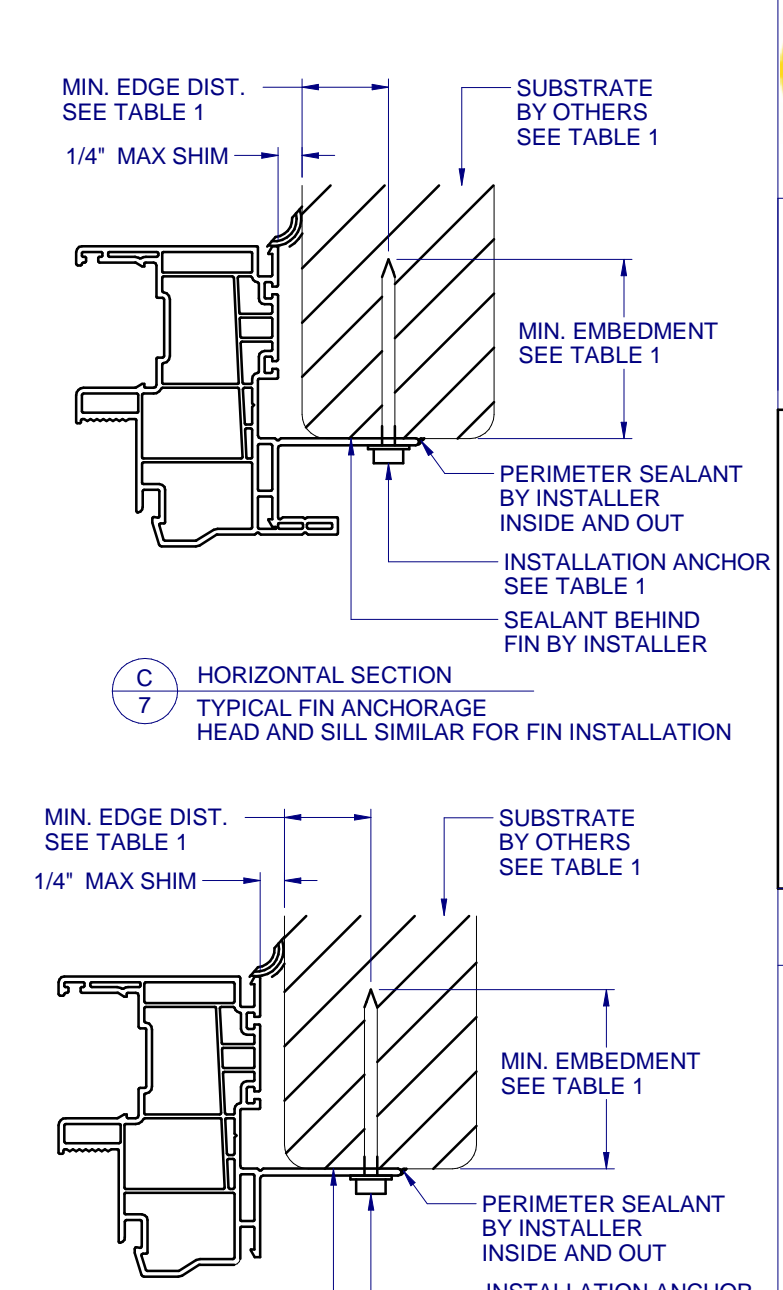
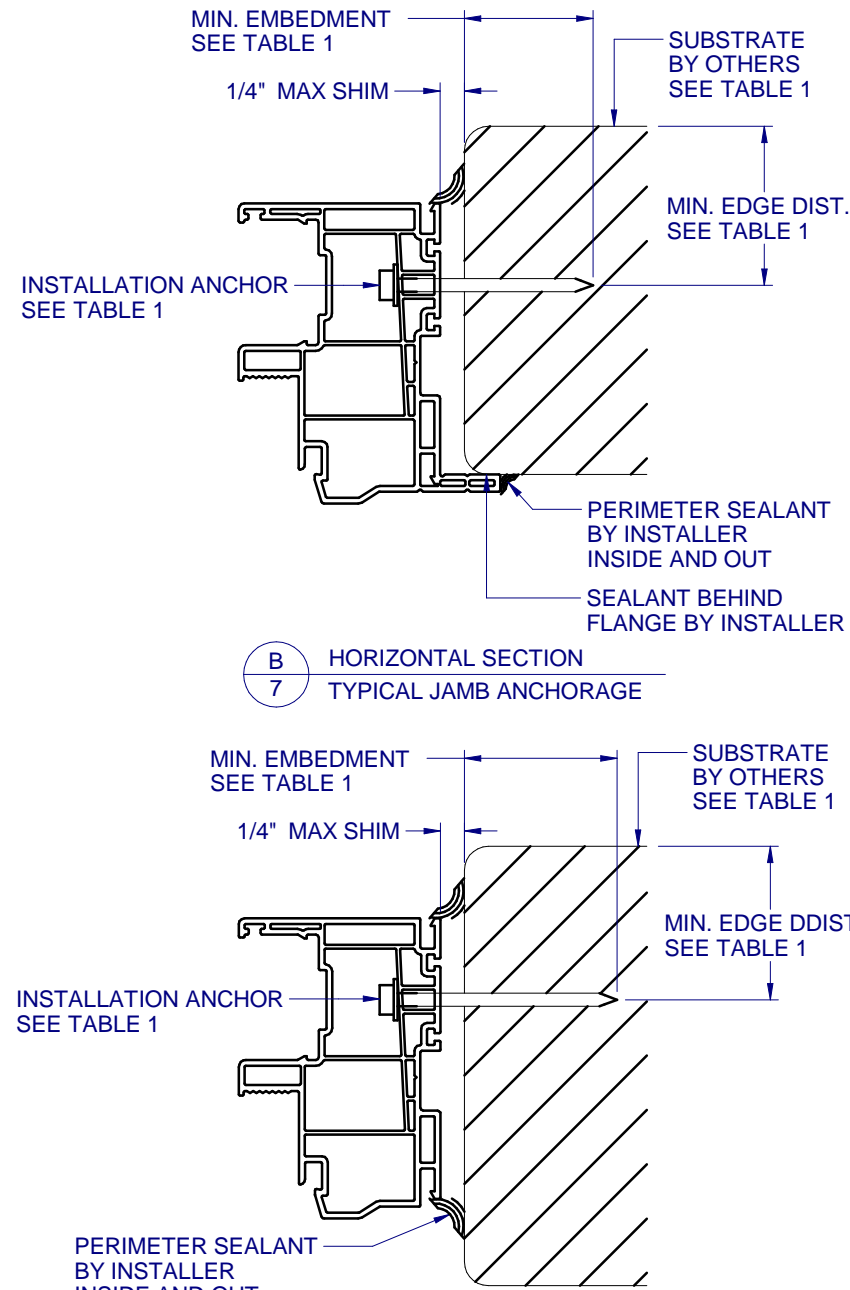
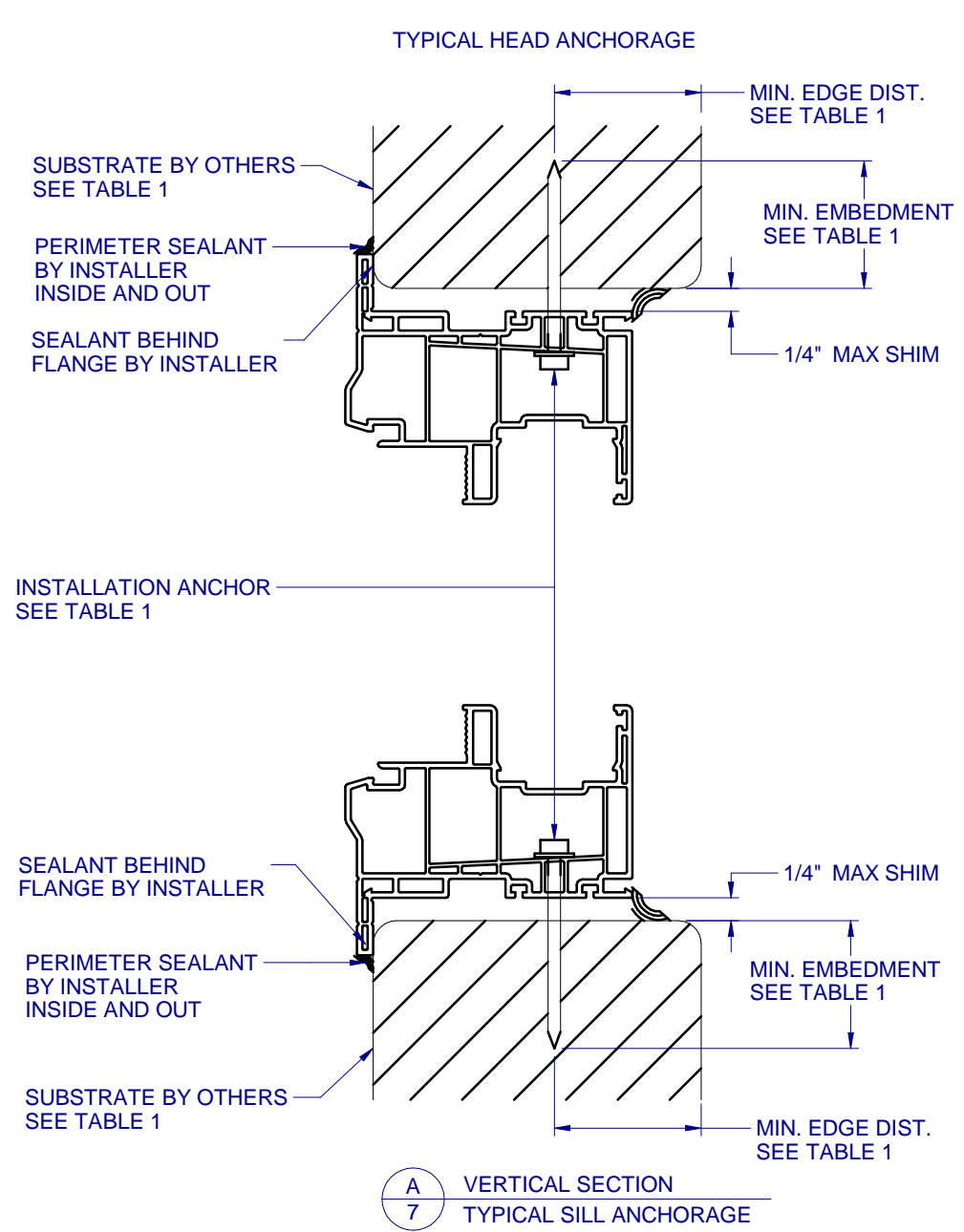

TABLE 1: APPROVED INSTALLATION FASTENERS				
FRAME TYPE	SUBSTRATE TYPE	ANCHOR TYPE	MIN. EMBEDMENT	MIN. EDGE DIST.
FLANGE	CONCRETE (2.0 KSI MIN.)	3/16" ITW TAPCON	1-1/2"	1-1/8"
FLANGE	HOLLOW OR GROUT-FILLED CMU (117 PCF MIN.)	3/16" ITW TAPCON	1"	2"
FLANGE	CONCRETE (3.05 KSI MIN.)	3/16" DEWALT ULTRACON+	1-3/4"	1"
FLANGE	HOLLOW OR GROUT-FILLED CMU (ASTM C-90)	3/16" DEWALT ULTRACON+	1-1/4"	2-1/2"
FLANGE	2X MIN. SOUTHERN PINE (G=0.55)	3/16" ITW TAPCON OR DEWALT ULTRACON+	1-3/8"	7/8"
FLANGE	2X MIN. SOUTHERN PINE (G=0.55)	#10 WOOD SCREW	1-3/8"	7/8"
FLANGE	16 GAUGE (0.060") MIN. STEEL STUD (33 KSI YIELD MIN)	#10-16 HILTI KWIK-FLEX OR ITW TEKS SELF-DRILLING SCREW	FULL THREAD THRU 0.060"	7/16"
FLANGE	1/8" ALUM. (6063-T5 MIN.) OR 1/8" STEEL (33 KSI MIN.)	#10 GRADE 5 SELF-TAPPING / DRILLING SCREW	FULL THREAD THRU 0.125"	7/16"
FIN	2X MIN. SOUTHERN PINE (G=0.55)	#10 WOOD SCREW	1-1/2"	1/2"

FLANGE REMOVAL NOTE: PARTIALLY OR FULLY REMOVING THE FLANGE, UP TO AND INCLUDING A BOX-FRAME APPLICATION IS ACCEPTABLE PROVIDED:

- MIN. 1/4" FILLET OF CONSTRUCTION-GRADE ADHESIVE CAULK IS APPLIED INSIDE AND OUT, FULL PERIMETER, BY INSTALLER.
- PRODUCT ANCHORAGE IS IN ACCORDANCE WITH REQUIREMENTS AS SHOWN FOR FLANGE WINDOWS.