

# PICTURE WINDOW - NON-IMPACT

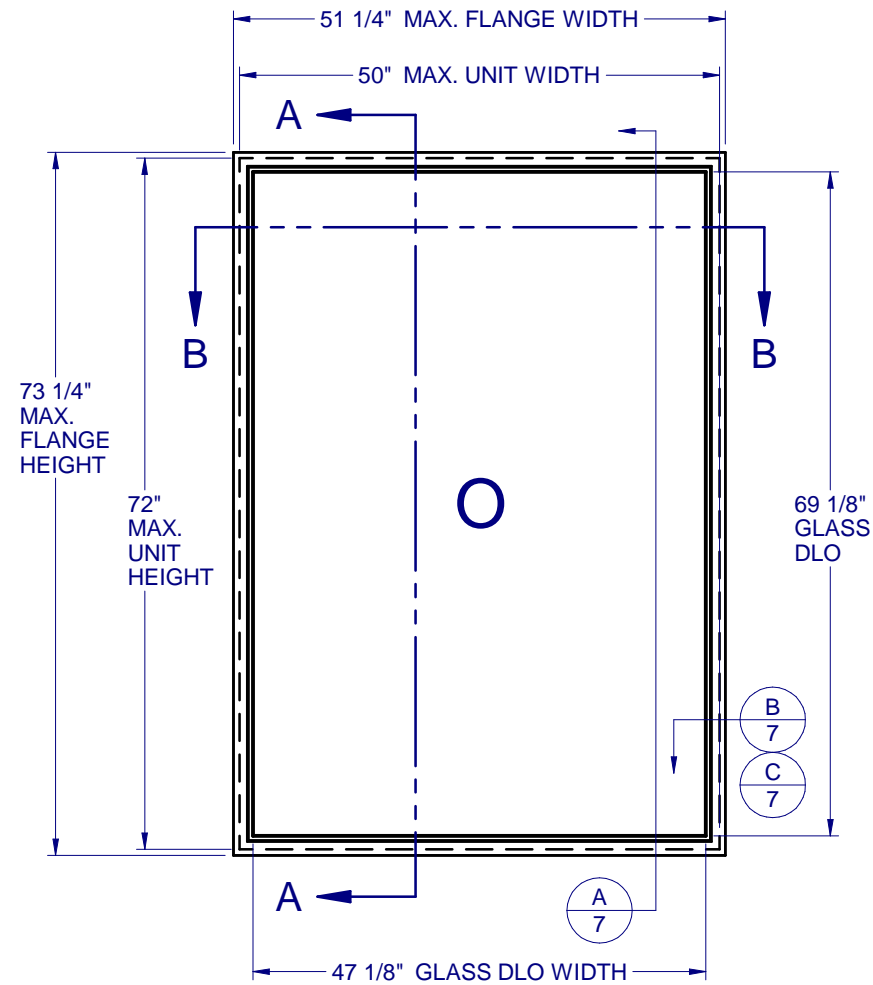

## GENERAL NOTES:

1. THE PRODUCT SHOWN HEREIN IS DESIGNED AND MANUFACTURED TO COMPLY WITH THE FLORIDA BUILDING CODE (FBC), CURRENT EDITION AND IS RATED FOR USE IN THE HIGH VELOCITY HURRICANE ZONE (HVHZ).
2. GLAZING OPTIONS: (SEE SHEET 3)
3. CONFIGURATIONS: "O". ARCHITECTURAL SHAPES INCLUDE, BUT ARE NOT LIMITED TO, THOSE SHOWN ON SHEET 2.
4. DESIGN PRESSURE RATING (SEE SHEET 3):  
 -NEGATIVE DESIGN LOADS BASED ON, TESTED PRESSURE AND GLASS TABLES ASTM E-1300-04e01/09.  
 -POSITIVE DESIGN LOADS BASED ON, TESTED PRESSURE, WATER INFILTRATION TEST PRESSURE AND GLASS TABLES ASTM E-1300-04e01/09.
5. ANCHORAGE: THE 33 1/3% STRESS INCREASE HAS NOT BEEN USED IN THE DESIGN OF THIS PRODUCT. SEE SHEET 7 FOR ANCHOR DETAILS. WINDLOAD DURATION FACTOR Cd=1.6 WAS USED FOR WOOD ANCHOR CALCULATIONS.
6. NOT APPROVED FOR IMPACT RESISTANCE. IMPACT PROTECTIVE SYSTEM IS REQUIRED IN WIND BORNE DEBRIS REGION.
7. ALL FRAMES FULLY WELDED.
8. SERIES / MODEL DESIGNATION PW-8300.
9. THE DESIGNATION X AND O STAND FOR THE FOLLOWING:  
 O = FIXED SASH
10. PICTURE WINDOWS CAN BE INSTALLED IN ANY ORIENTATION



## 530 PVC FIXED WINDOW NON-IMPACT

PROPRIETARY AND CONFIDENTIAL  
 THE INFORMATION CONTAINED IN THIS DRAWING IS THE SOLE PROPERTY OF CUSTOM WINDOW SYSTEMS, INC. ANY REPRODUCTION IN PART OR AS A WHOLE WITHOUT THE WRITTEN PERMISSION OF CUSTOM WINDOW SYSTEMS, INC IS PROHIBITED.

FLORIDA APPROVAL NO.:  
33453



8/15/2023

LUCAS A. TURNER, P.E.  
 FL PE # 58201  
 Turner Engineering & Consulting, Inc.  
 2428 Old Natchez Trc Trl  
 Camden, TN 38320  
 PH. 941-380-1574

SHEET DESCRIPTION:  
 GENERAL NOTES AND ELEVATIONS

DRAWN BY: MCS	DATE: 8/9/2023
DWG #: PEL-507	REV.: A
SCALE: 1:20	SHEET 1 OF 7

## TABLE OF CONTENTS

GENERAL NOTES & ELEVATIONS.....	1
ARCHITECTURAL SHAPES.....	2
COMPARATIVE ANALYSIS & GLAZING DETAILS.....	3
SECTION VIEWS.....	4
BOM & EXTRUSIONS.....	5
ANCHOR SCHEDULE & NOTES.....	6
INSTALLATION DETAILS.....	7

MAX. UNIT SIZE	DESIGN PRESSURE RATING	IMPACT RATING
50" x 72"	SEE COMPARATIVE ANALYSIS CHART, SHEET 3	NONE

**530 PVC  
FIXED WINDOW  
NON-IMPACT**

PROPRIETARY AND CONFIDENTIAL  
THE INFORMATION CONTAINED IN  
THIS DRAWING IS THE SOLE  
PROPERTY OF CUSTOM WINDOW  
SYSTEMS, INC. ANY  
REPRODUCTION IN PART OR AS A  
WHOLE WITHOUT THE WRITTEN  
PERMISSION OF CUSTOM WINDOW  
SYSTEMS, INC IS PROHIBITED.

FLORIDA APPROVAL NO.:

33453

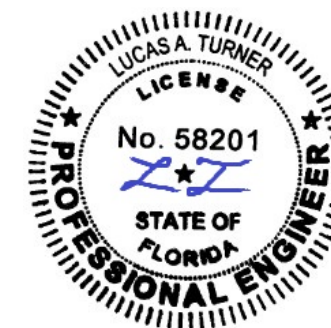

8/15/2023

LUCAS A. TURNER, P.E.  
FL PE # 58201  
Turner Engineering &  
Consulting, Inc.  
2428 Old Natchez Trc Trl  
Camden, TN 38320  
PH. 941-380-1574

SHEET DESCRIPTION:

**ARCHITECTURAL  
SHAPES**

DRAWN BY:

MCS

DATE:

8/9/2023

DWG #:

PEL-507

REV.:

A

SCALE:

1:20

SHEET

2 OF 7

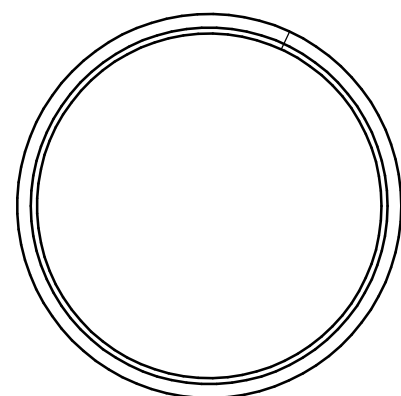

FULL CIRCLE

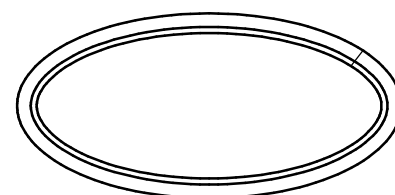

FULL ELLIPSE (OVAL)

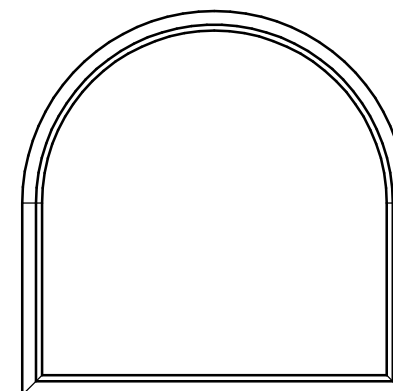

TOMBSTONE

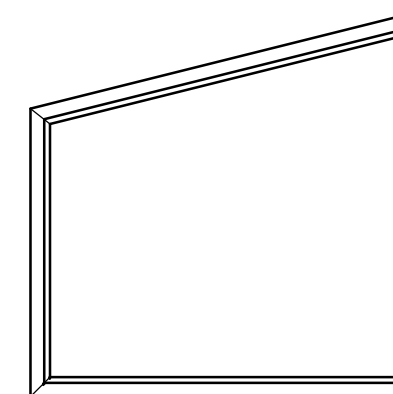

TRAPEZOID

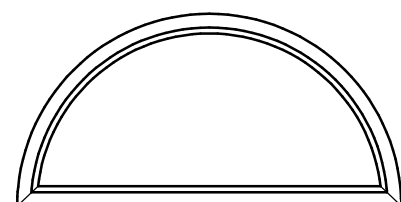

1/2 CIRCLE

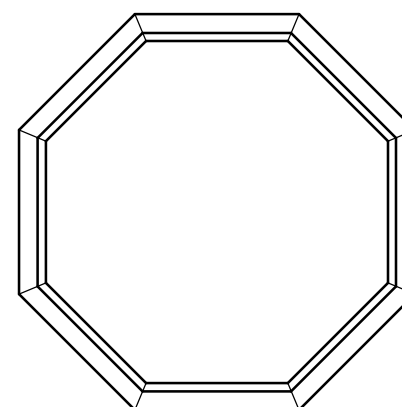

OCTAGON

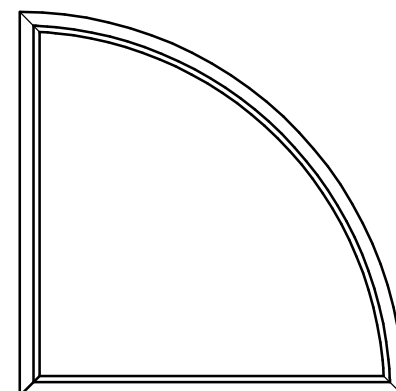

1/4 CIRCLE

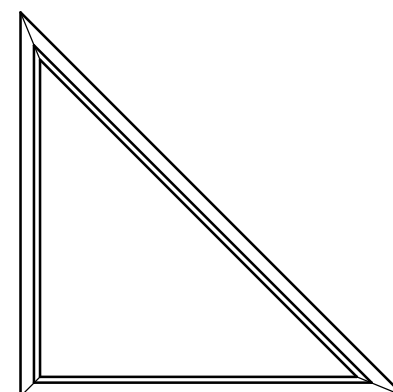

TRIANGLE

NOTES:

1. SEE SHEET 6 FOR DETAILED ANCHOR INSTALLATION REQUIREMENTS.
2. THRU FRAME - MASONRY, WOOD OR METAL OPENING.
3. OVERALL SIZE MUST NOT EXCEED THE MAX. WIDTH AND HEIGHT OF RECTANGULAR WINDOWS ON SHEET 1.
4. ANCHOR SPACING FOR ARCHITECTURAL FLANGE WINDOWS MUST FOLLOW THE LAYOUT SHOWN ON SHEET 6, WITH ANCHOR SPACING MEASURED ALONG THE LENGTH OF THE PRODUCT.

**DESIGN PRESSURES (PSF) WITH GLASS TYPE A or B IGU GLAZING (DIMENSIONS ARE UNIT SIZES)**

Short Side (in.)	Long Side (in.)									
	18.000	24.000	30.000	36.000	42.000	48.000	54.000	60.000	66.000	72.000
18.000	+82.5/-82.5	+82.5/-82.5	+82.5/-82.5	+82.5/-82.5	+82.5/-82.5	+82.5/-82.5	+82.5/-82.5	+82.5/-82.5	+82.5/-82.5	+82.5/-82.5
24.000	+82.5/-82.5	+82.5/-82.5	+82.5/-82.5	+82.5/-82.5	+82.5/-82.5	+82.5/-82.5	+82.5/-82.5	+82.5/-82.5	+82.5/-82.5	+82.5/-82.5
30.000	+82.5/-82.5	+82.5/-82.5	+82.5/-82.5	+82.5/-82.5	+82.5/-82.5	+82.5/-82.5	+82.5/-82.5	+82.5/-82.5	+82.5/-82.5	+75.6/-75.6
36.000	+82.5/-82.5	+82.5/-82.5	+82.5/-82.5	+82.5/-82.5	+82.5/-82.5	+82.5/-82.5	+82.5/-82.5	+82.5/-82.5	+74.8/-74.8	+66.5/-66.5
42.000	+82.5/-82.5	+82.5/-82.5	+82.5/-82.5	+82.5/-82.5	+77.9/-77.9	+77.9/-77.9	+77.9/-77.9	+77.9/-77.9	+68.4/-68.4	+60.3/-60.3
48.000	+82.5/-82.5	+82.5/-82.5	+82.5/-82.5	+82.5/-82.5	+77.9/-77.9	+59.7/-59.7	+59.7/-59.7	+59.7/-59.7	+59.7/-59.7	+56.1/-56.1
50.000	+82.5/-82.5	+82.5/-82.5	+82.5/-82.5	+82.5/-82.5	+77.9/-77.9	+59.7/-59.7	+55.0/-55.0	+55.0/-55.0	+55.0/-55.0	+55.0/-55.0



**530 PVC  
FIXED WINDOW  
NON-IMPACT**

PROPRIETARY AND CONFIDENTIAL  
THE INFORMATION CONTAINED IN THIS DRAWING IS THE SOLE PROPERTY OF CUSTOM WINDOW SYSTEMS, INC. ANY REPRODUCTION IN PART OR AS A WHOLE WITHOUT THE WRITTEN PERMISSION OF CUSTOM WINDOW SYSTEMS, INC IS PROHIBITED.

FLORIDA APPROVAL NO.:  
33453

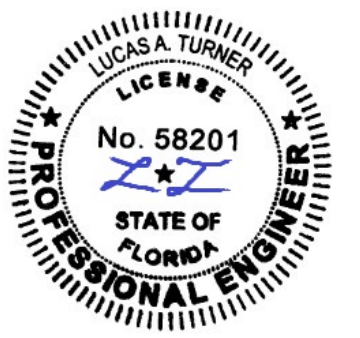

8/15/2023  
LUCAS A. TURNER, P.E.  
FL PE # 58201  
Turner Engineering & Consulting, Inc.  
2428 Old Natchez Trc Trl  
Camden, TN 38320  
PH. 941-380-1574

SHEET DESCRIPTION:  
COMPARATIVE ANALYSIS  
AND GLAZING DETAILS

DRAWN BY: MCS	DATE: 8/9/2023
DWG #: PEL-507	REV.: A
SCALE: 1:1	SHEET 3 OF 7

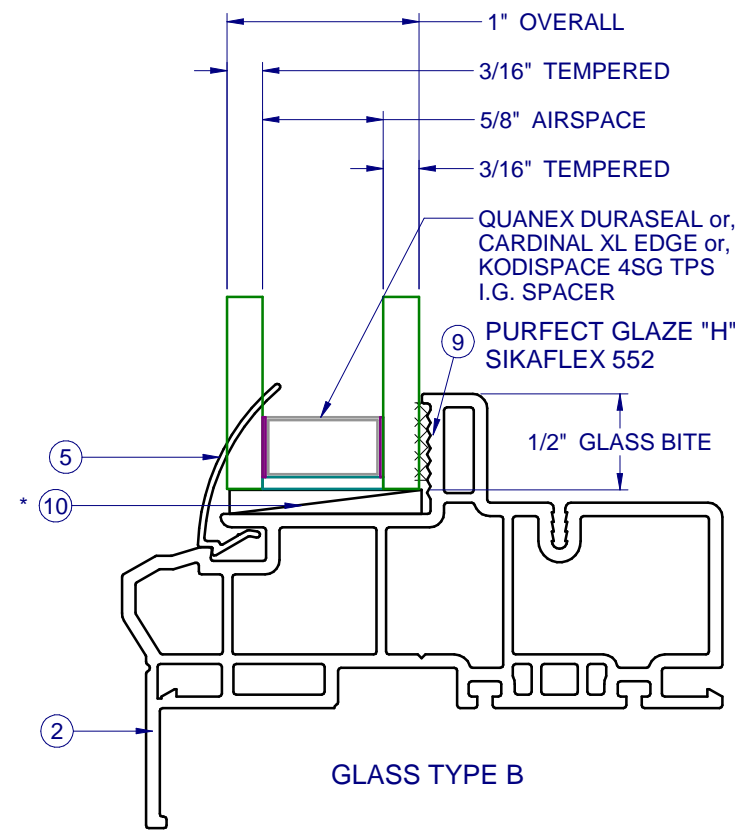
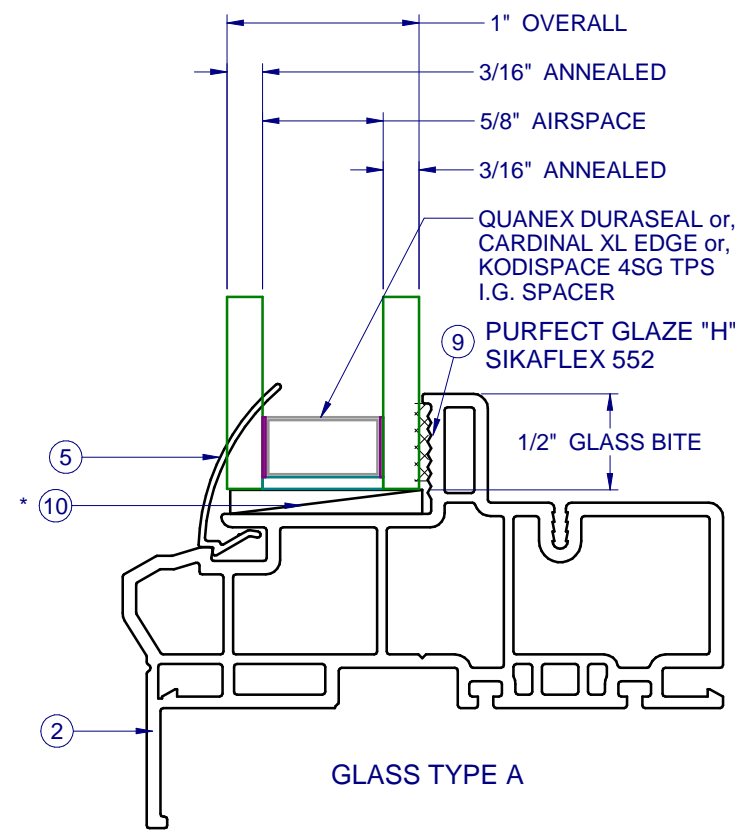

\* SETTING BLOCKS PER FBC 2411.3.3.1

NOTE: IF SIZE INTENDED IS NOT SHOWN, USE NEXT LARGER SIZE.

**530 PVC  
 FIXED WINDOW  
 NON-IMPACT**

PROPRIETARY AND CONFIDENTIAL  
 THE INFORMATION CONTAINED IN  
 THIS DRAWING IS THE SOLE  
 PROPERTY OF CUSTOM WINDOW  
 SYSTEMS, INC. ANY  
 REPRODUCTION IN PART OR AS A  
 WHOLE WITHOUT THE WRITTEN  
 PERMISSION OF CUSTOM WINDOW  
 SYSTEMS, INC IS PROHIBITED.

FLORIDA APPROVAL NO.:  
 33453

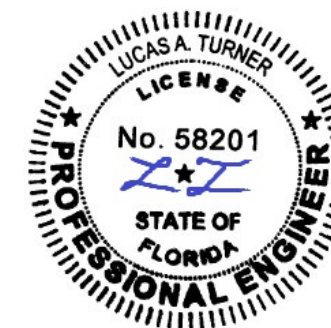

8/15/2023

LUCAS A. TURNER, P.E.  
 FL PE # 58201  
 Turner Engineering &  
 Consulting, Inc.  
 2428 Old Natchez Trc Trl  
 Camden, TN 38320  
 PH. 941-380-1574

SHEET DESCRIPTION:

**SECTION VIEWS**

DRAWN BY: <b>MCS</b>	DATE: <b>8/9/2023</b>
DWG #: <b>PEL-507</b>	REV.: <b>A</b>
SCALE: <b>1:1</b>	<b>SHEET 4 OF 7</b>

INTERIOR

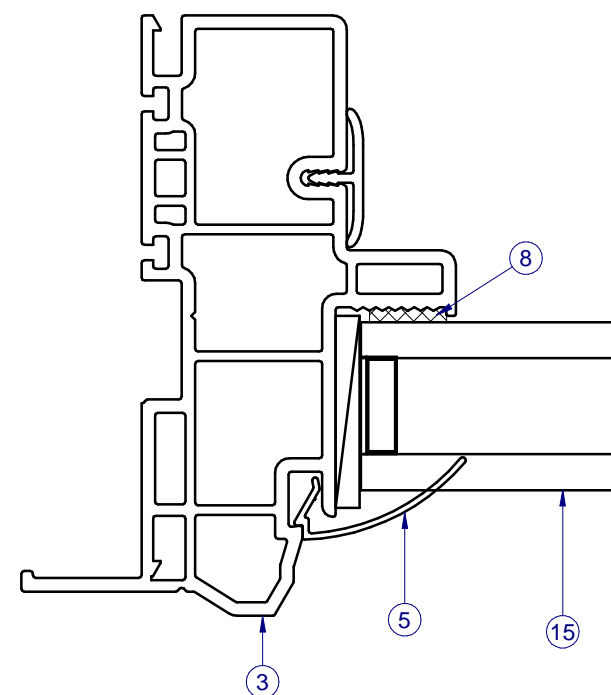

SECTION VIEW B-B

INTERIOR

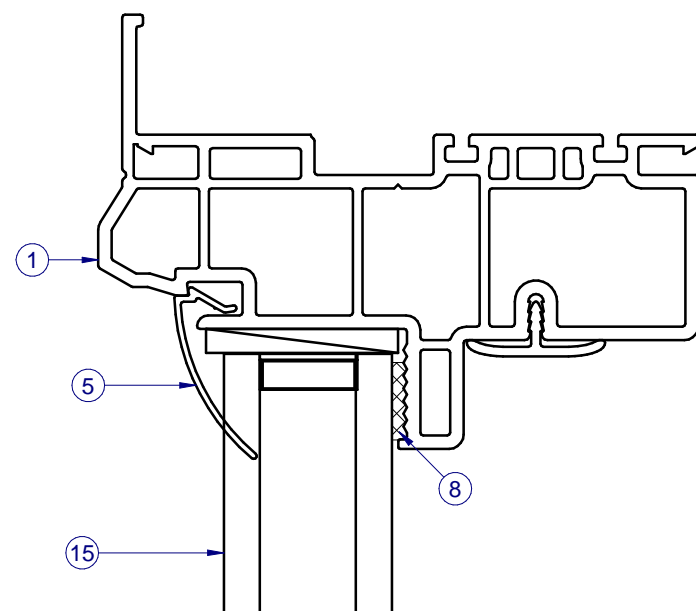

SECTION VIEW A-A

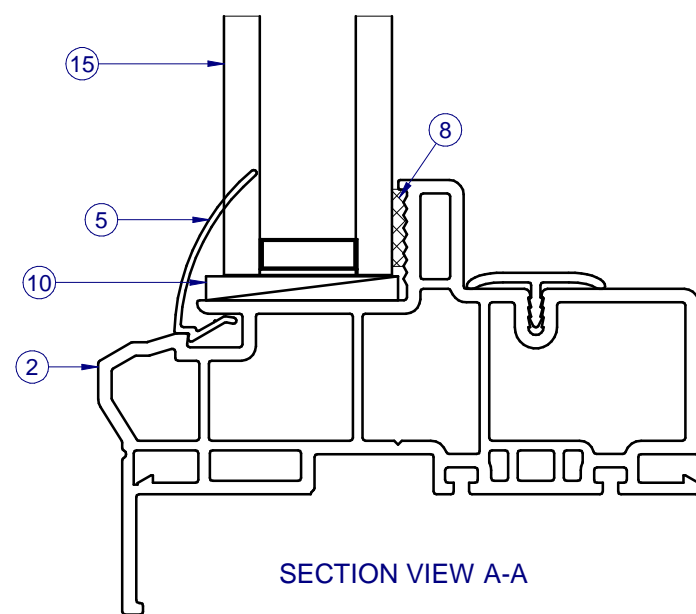

ITEMS NOT SHOWN FOR CLARITY:  
 9, 11-14

PARTS LIST			
ITEM	PART #	DESCRIPTION	MATERIAL
1	H-6232	FRAME-PVC, FIN/FLANGE	PVC
2	H-6232	FRAME PVC, FIN/FLANGE	PVC
3	H-6232	FRAME PVC, FIN/FLANGE	PVC
4	H-6232	FRAME PVC, FIN/FLANGE	PVC
5	S-6237	GLAZING BEAD, FIXED	PVC
8	S-6233	Trim Cover	PVC
9		SIKAFLEX 552 OR PURFECT GLAZE "H"	
10	P-5531	Setting Block, .09 x 1 x 2	Rubber
11		PW-8300 Gold Cert. Label, NFRC Tab	
13		NFRC LABEL, BLANK 4 X 8 LABEL	
14		LABEL, 9X9 CWS Logo Label	
15	GLASS	SEE SHEET 3	

LINE ITEMS NOT USED:  
6-7, 12, 16

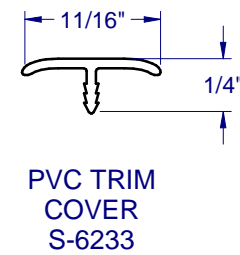
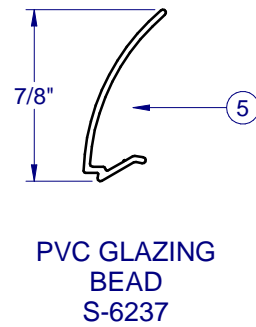
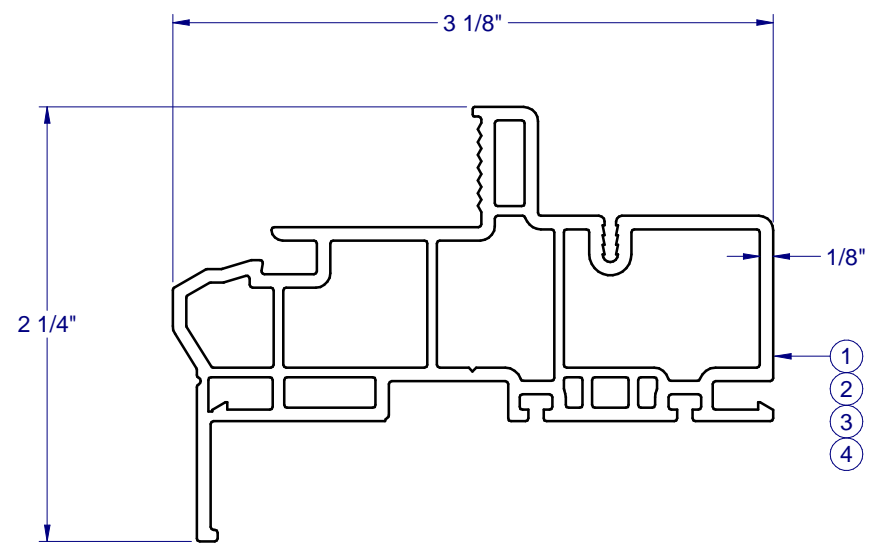

FRAME CORNER CONSTRUCTION

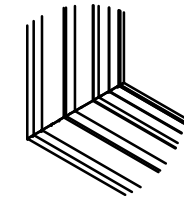

CORNER WELD  
(ALL SIDES)  
1:8



**530 PVC  
FIXED WINDOW  
NON-IMPACT**

PROPRIETARY AND CONFIDENTIAL  
THE INFORMATION CONTAINED IN THIS DRAWING IS THE SOLE PROPERTY OF CUSTOM WINDOW SYSTEMS, INC. ANY REPRODUCTION IN PART OR AS A WHOLE WITHOUT THE WRITTEN PERMISSION OF CUSTOM WINDOW SYSTEMS, INC IS PROHIBITED.

FLORIDA APPROVAL NO.:  
33453



8/15/2023

LUCAS A. TURNER, P.E.  
FL PE # 58201  
Turner Engineering & Consulting, Inc.  
2428 Old Natchez Trc Trl  
Camden, TN 38320  
PH. 941-380-1574

SHEET DESCRIPTION:

**BOM AND EXTRUSIONS**

DRAWN BY: MCS	DATE: 8/9/2023
DWG #: PEL-507	REV.: A
SCALE: 1:1	SHEET 5 OF 7

**530 PVC  
 FIXED WINDOW  
 NON-IMPACT**

PROPRIETARY AND CONFIDENTIAL  
 THE INFORMATION CONTAINED IN  
 THIS DRAWING IS THE SOLE  
 PROPERTY OF CUSTOM WINDOW  
 SYSTEMS, INC. ANY  
 REPRODUCTION IN PART OR AS A  
 WHOLE WITHOUT THE WRITTEN  
 PERMISSION OF CUSTOM WINDOW  
 SYSTEMS, INC IS PROHIBITED.

FLORIDA APPROVAL NO.:  
 33453

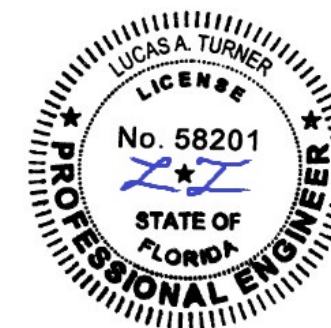

8/15/2023

LUCAS A. TURNER, P.E.  
 FL PE # 58201  
 Turner Engineering &  
 Consulting, Inc.  
 2428 Old Natchez Trc Trl  
 Camden, TN 38320  
 PH. 941-380-1574

SHEET DESCRIPTION:  
**ANCHOR SCHEDULE AND  
 NOTES**

DRAWN BY: <b>MCS</b>	DATE: <b>8/9/2023</b>
DWG #: <b>PEL-507</b>	REV.: <b>A</b>
SCALE: <b>1:20</b>	<b>SHEET 6 OF 7</b>

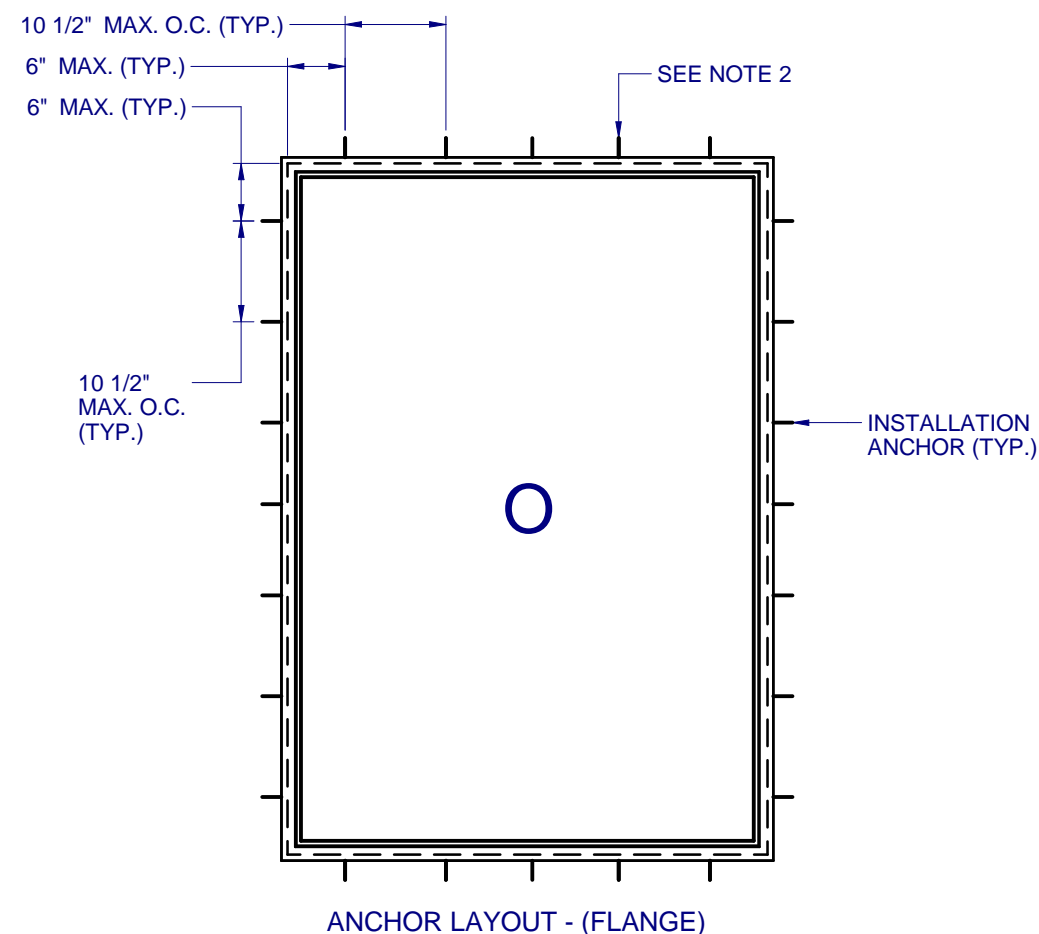

**NOTES:**

1. INSTALL ONE ANCHOR AT EACH INSTALLATION LOCATION. ANCHOR SPACING APPLIES TO ALL SHAPES (SEE SHEET 2) ALONG ALL FRAME EDGES. SILL ANCHOR SPACING SAME AS HEAD.
2. SHIM AS REQ AT EACH INSTALLATION ANCHOR USING LOAD BEARING SHIMS. MAX. ALLOWABLE SHIM STACK TO BE 1/4". USE SHIMS WHERE SPACE GREATER THAN 1/16" IS PRESENT. LOAD BEARING SHIMS SHALL BE CONSTRUCTED OF HIGH DENSITY PLASTIC OR BETTER. WOOD SHIMS ARE NOT ALLOWED.
3. ANCHOR TYPE, SIZE, SPACING AND EMBEDMENT SHALL BE AS SPECIFIED IN THESE DRAWINGS, SEE TABLE 1, SHEET 7.
4. ALL INSTALLATION ANCHORS MUST BE MADE OF OR PROTECTED WITH A CORROSION RESISTANT MATERIAL OR COATING. DISSIMILAR METALS OR MATERIALS IN CONTACT WITH PRESSURE TREATED WOOD MUST BE PROTECTED TO PREVENT REACTION.
5. INSTALLATION ANCHORS SHALL BE IN ACCORDANCE WITH ANCHOR MANUFACTURER'S INSTALLATION INSTRUCTIONS, AND ANCHORS SHALL NOT BE USED IN SUBSTRATES WITH STRENGTHS LESS THAN THE MINIMUM SPECIFIED IN TABLE 1, SHEET 7.
6. ANCHOR EMBEDMENT TO SUBSTRATE SHALL BE BEYOND WALL DRESSING OR STUCCO. FOR CONCRETE/CMU OPENINGS, EMBEDMENT SHALL BE BEYOND WOOD BUCKS, IF USED, INTO SUBSTRATE - 1X BUCKS ARE OPTIONAL.
7. A MINIMUM CENTER-TO-CENTER SPACING SHALL BE MAINTAINED BETWEEN ALL FASTENERS: 3" FOR MASONRY, 1" FOR WOOD AND METAL.
8. WOOD OR MASONRY OPENINGS, BUCKS AND BUCK FASTENERS SHALL BE PROPERLY DESIGNED BY THE ARCHITECT OR ENGINEER OF RECORD AND INSTALLED TO TRANSFER WIND LOADS TO THE STRUCTURE. SUBSTRATES SHALL MEET THE MINIMUM STRENGTH REQUIREMENTS AS SHOWN IN TABLE 1, SHEET 7. CONCRETE AND MASONRY SUBSTRATES MAY NOT BE CRACKED.
9. SEALING AND FLASHING STRATEGIES FOR OVERALL WATER RESISTANCE OF INSTALLATION SHALL BE DONE BY OTHERS FOLLOWING THE CURRENT VERSION OF THE REFERENCE DOCUMENTS:  
 FMA/AAMA 100(FIN WINDOWS), FMA/AAMA 200(FLANGE WINDOWS), FMA/WDMA 250(BOX WINDOWS), FMA/AAMA/WDMA 300(EXTERIOR DOORS)

**530 PVC  
 FIXED WINDOW  
 NON-IMPACT**

PROPRIETARY AND CONFIDENTIAL  
 THE INFORMATION CONTAINED IN  
 THIS DRAWING IS THE SOLE  
 PROPERTY OF CUSTOM WINDOW  
 SYSTEMS, INC. ANY  
 REPRODUCTION IN PART OR AS A  
 WHOLE WITHOUT THE WRITTEN  
 PERMISSION OF CUSTOM WINDOW  
 SYSTEMS, INC IS PROHIBITED.

FLORIDA APPROVAL NO.:  
 33453



8/15/2023  
 LUCAS A. TURNER, P.E.  
 FL PE # 58201  
 Turner Engineering &  
 Consulting, Inc.  
 2428 Old Natchez Trc Trl  
 Camden, TN 38320  
 PH. 941-380-1574

SHEET DESCRIPTION:  
**INSTALLATION DETAILS**

DRAWN BY: <b>MCS</b>	DATE: <b>8/9/2023</b>
DWG #: <b>PEL-507</b>	REV.: <b>A</b>
SCALE: <b>1:2</b>	<b>SHEET 7 OF 7</b>

TYPICAL HEAD ANCHORAGE

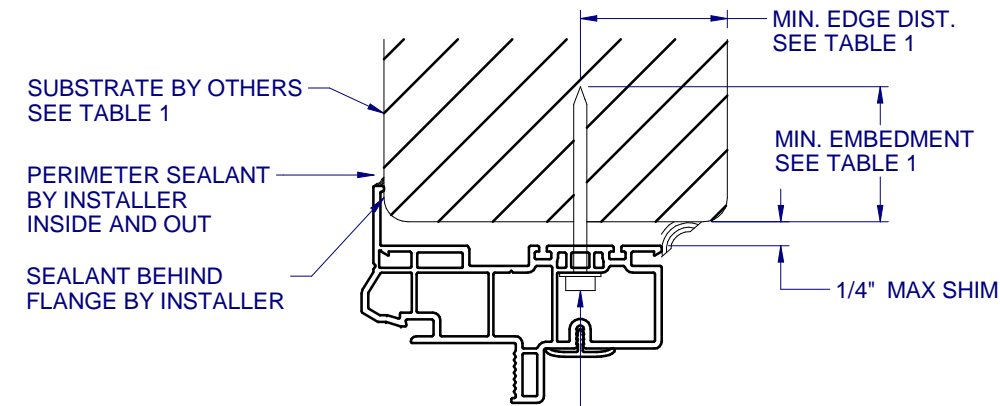

INSTALLATION ANCHOR SEE TABLE 1

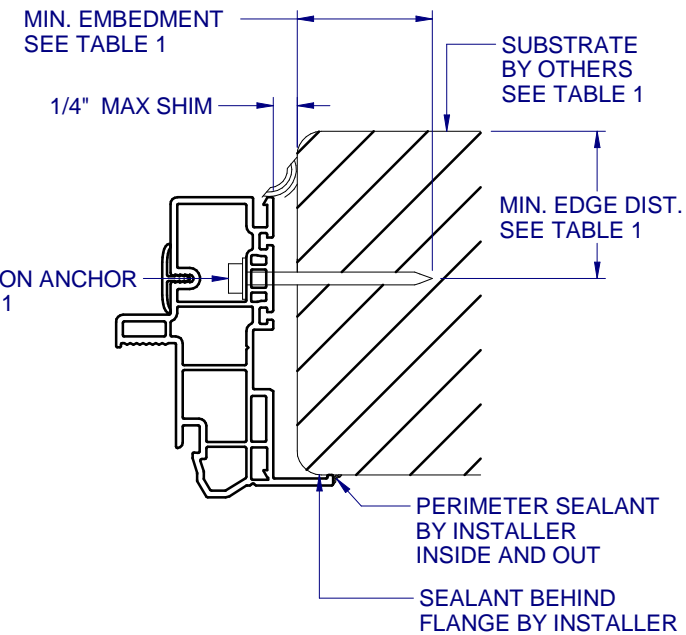
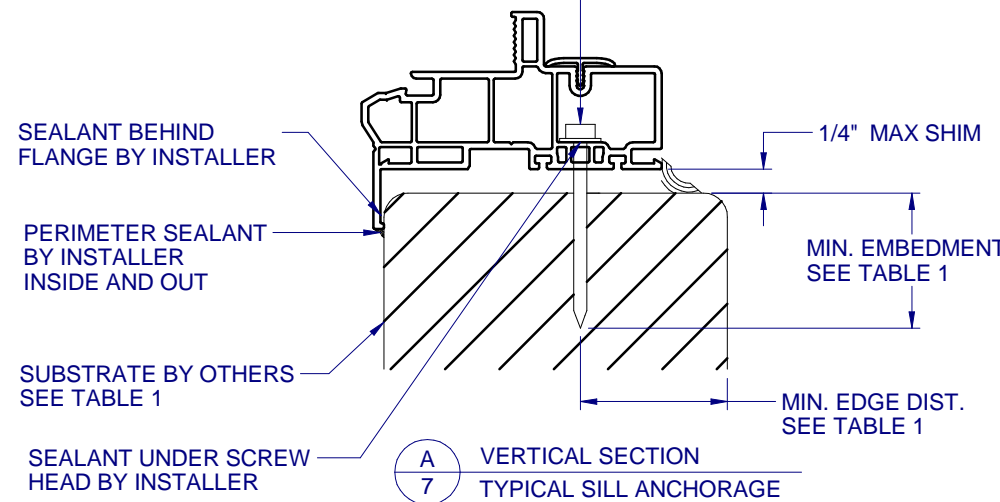

B 7 HORIZONTAL SECTION TYPICAL JAMB ANCHORAGE

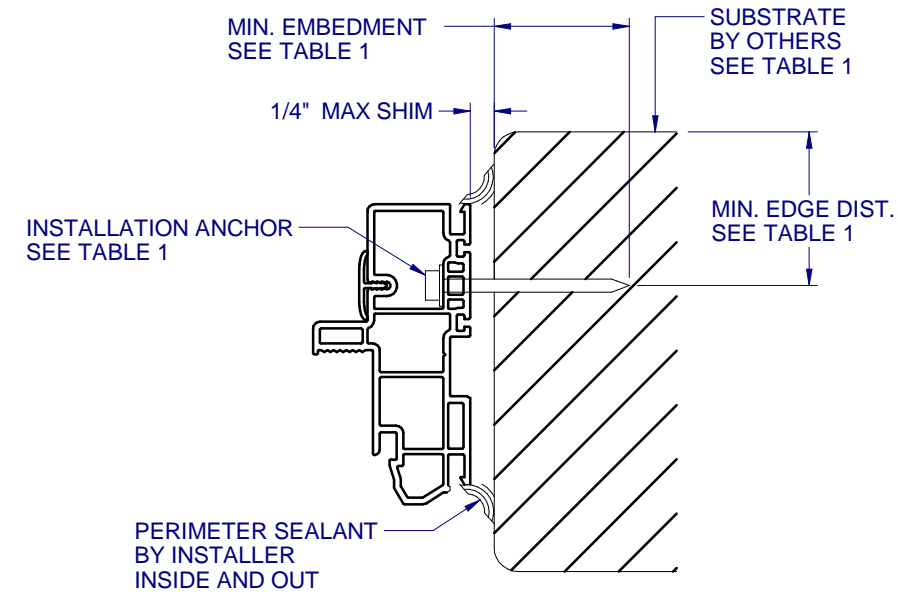

C 7 HORIZONTAL SECTION BOX FRAME INSTALLATION HEAD AND SILL SIMILAR FOR BOX INSTALLATION

SUBSTRATE TYPE	ANCHOR TYPE	MIN. EMBEDMENT	MIN. EDGE DIST.
CONCRETE (2.0 KSI MIN.)	3/16" ITW TAPCON	1-1/2"	1-1/8"
HOLLOW OR GROUT-FILLED CMU (117 PCF MIN.)	3/16" ITW TAPCON	1"	2"
CONCRETE (3.05 KSI MIN.)	3/16" DEWALT ULTRACON+	1-3/4"	1"
HOLLOW OR GROUT-FILLED CMU (ASTM C-90)	3/16" DEWALT ULTRACON+	1-1/4"	2-1/2"
2X MIN. SOUTHERN PINE (G=0.55)	3/16" ITW TAPCON OR DEWALT ULTRACON+	1-3/8"	7/8"
2X MIN. SOUTHERN PINE (G=0.55)	#10 WOOD SCREW	1-3/8"	7/8"
16 GAUGE (0.060") MIN. STEEL STUD (33 KSI YIELD MIN)	#10-16 HILTI KWIK-FLEX OR ITW TEKS SELF-DRILLING SCREW	FULL THREAD THRU 0.060"	7/16"
1/8" ALUM. (6063-T5 MIN.) OR 1/8" STEEL (33 KSI MIN.)	#10 GRADE 5 SELF-TAPPING / DRILLING SCREW	FULL THREAD THRU 0.125"	7/16"

FLANGE REMOVAL NOTE: PARTIALLY OR FULLY REMOVING THE FLANGE, UP TO AND INCLUDING A BOX-FRAME APPLICATION IS ACCEPTABLE PROVIDED:

- MIN. 1/4" FILLET OF CONSTRUCTION-GRADE ADHESIVE CAULK IS APPLIED INSIDE AND OUT, FULL PERIMETER, BY INSTALLER.
- PRODUCT ANCHORAGE IS IN ACCORDANCE WITH REQUIREMENTS AS SHOWN FOR FLANGE WINDOWS.