

PICTURE WINDOW - LARGE MISSILE IMPACT

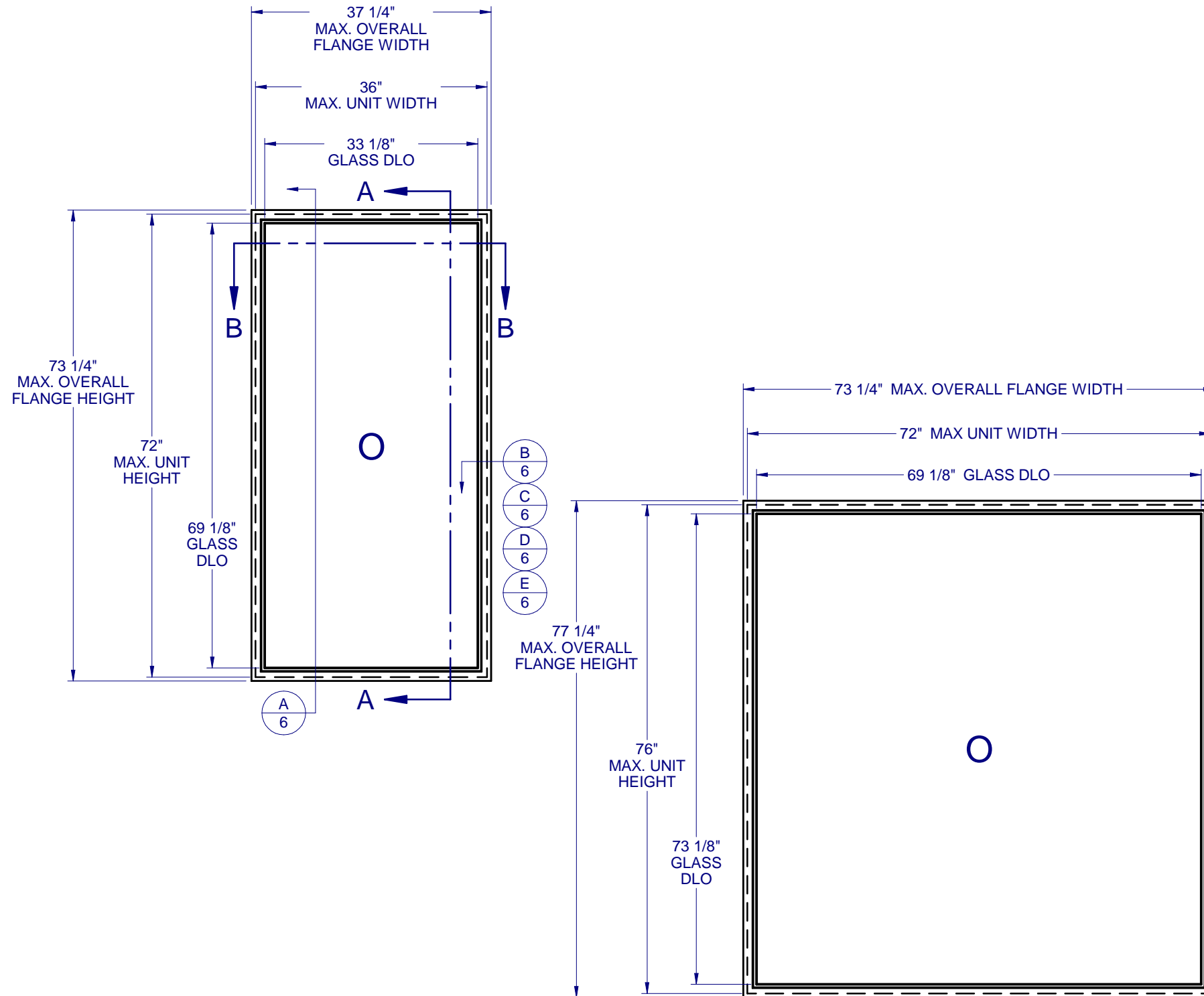

GENERAL NOTES:

1. THE PRODUCT SHOWN HEREIN IS DESIGNED AND MANUFACTURED TO COMPLY WITH THE FLORIDA BUILDING CODE (FBC), CURRENT EDITION INCLUDING THE HIGH VELOCITY HURRICANE ZONE (HVHZ) AND IS RATED FOR WIND ZONE 4 MISSILE LEVEL D IMPACT USE AS DEFINED IN ASTM E 1996 PER THE FBC.
2. GLAZING OPTIONS: (SEE SHEET 3)
3. CONFIGURATIONS: "O". ARCHITECTURAL SHAPES INCLUDE, BUT ARE NOT LIMITED TO, THOSE SHOWN ON SHEET 2.
4. DESIGN PRESSURE RATING:
 - NEGATIVE DESIGN LOADS BASED ON, TESTED PRESSURE AND GLASS TABLES ASTM E-1300-04e01/09.
 - POSITIVE DESIGN LOADS BASED ON, TESTED PRESSURE, WATER INFILTRATION TEST PRESSURE AND GLASS TABLES ASTM E-1300-04e01/09.
5. ANCHORAGE: THE 33 1/3% STRESS INCREASE HAS NOT BEEN USED IN THE DESIGN OF THIS PRODUCT. SEE SHEET 6 FOR ANCHOR DETAILS. WINDLOAD DURATION FACTOR Cd=1.6 WAS USED FOR WOOD ANCHOR CALCULATIONS.
6. PRODUCT APPROVED FOR IMPACT RESISTANCE. SHUTTERS ARE NOT REQUIRED.
7. ALL FRAMES ARE FULLY WELDED.
8. SERIES / MODEL DESIGNATION PW-8150.
9. THE DESIGNATION X AND O STAND FOR THE FOLLOWING:
 - O = FIXED SASH.
10. SECTION CALLOUTS APPLY TO ALL ELEVATIONS IN A SIMILAR LOCATION.
11. PICTURE WINDOWS CAN BE INSTALLED IN ANY ORIENTATION



515 PVC FIXED WINDOW IMPACT

PROPRIETARY AND CONFIDENTIAL
 THE INFORMATION CONTAINED IN THIS DRAWING IS THE SOLE PROPERTY OF CUSTOM WINDOW SYSTEMS, INC. ANY REPRODUCTION IN PART OR AS A WHOLE WITHOUT THE WRITTEN PERMISSION OF CUSTOM WINDOW SYSTEMS, INC IS PROHIBITED.

FLORIDA APPROVAL NO.:
33563

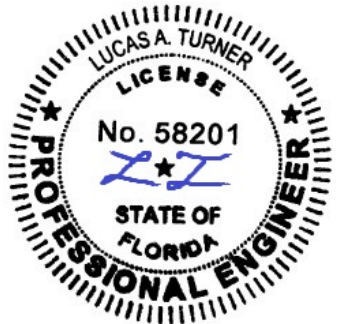

8/15/2023

LUCAS A. TURNER, P.E.
 FL PE # 58201
 Turner Engineering & Consulting, Inc.
 2428 Old Natchez Trc Trl
 Camden, TN 38320
 PH. 941-380-1574

SHEET DESCRIPTION:
GENERAL NOTES AND ELEVATIONS

DRAWN BY: MCS	DATE: 8/9/2023
DWG #: PEL-433	REV.: A
SCALE: 1:20	SHEET 1 OF 6

TABLE OF CONTENTS

GENERAL NOTES & ELEVATIONS.....1
 ARCHITECTURAL SHAPES.....2
 SECTION VIEWS & GLAZING DETAIL...3
 BOM & EXTRUSIONS.....4
 ANCHOR SCHEDULE & NOTES.....5
 INSTALLATION DETAILS.....6

LOCATION	MAX. UNIT SIZE	DESIGN PRESSURE RATING	IMPACT RATING
ALL	36" x 72"	+/- 75 PSF	LARGE MISSILE IMPACT
NON-HVHZ	72" x 76"	+/- 65 PSF	
HVHZ		+/- 67.5 PSF	

**515 PVC
FIXED WINDOW
IMPACT**

PROPRIETARY AND CONFIDENTIAL
THE INFORMATION CONTAINED IN
THIS DRAWING IS THE SOLE
PROPERTY OF CUSTOM WINDOW
SYSTEMS, INC. ANY
REPRODUCTION IN PART OR AS A
WHOLE WITHOUT THE WRITTEN
PERMISSION OF CUSTOM WINDOW
SYSTEMS, INC IS PROHIBITED.

FLORIDA APPROVAL NO.:
33563



8/15/2023

LUCAS A. TURNER, P.E.
FL PE # 58201
Turner Engineering &
Consulting, Inc.
2428 Old Natchez Trc Trl
Camden, TN 38320
PH. 941-380-1574

SHEET DESCRIPTION:

**ARCHITECTURAL
SHAPES**

DRAWN BY: MCS	DATE: 8/9/2023
DWG #: PEL-433	REV.: A
SCALE: 1:20	SHEET 2 OF 6

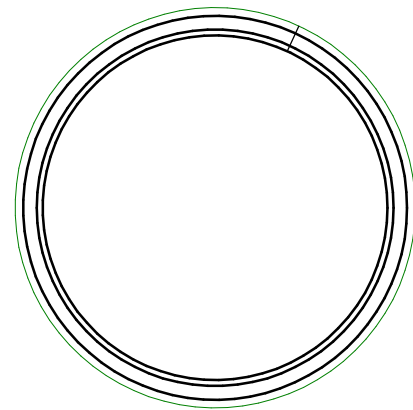

FULL CIRCLE

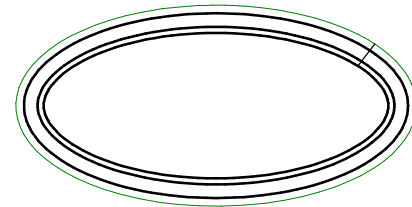

FULL ELLIPSE (OVAL)

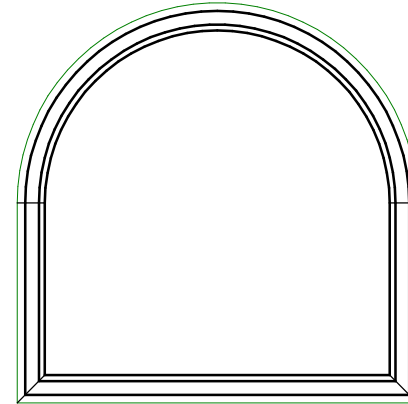

TOMBSTONE

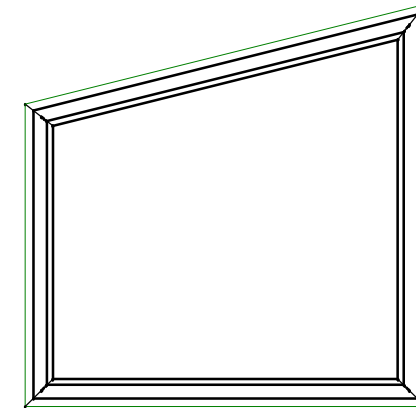

TRAPEZOID

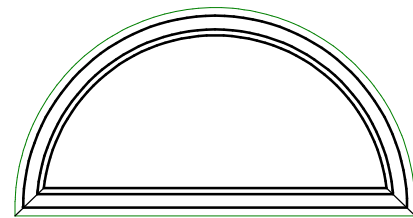

1/2 CIRCLE

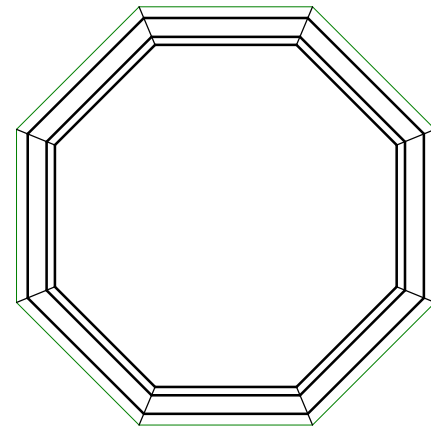

OCTAGON

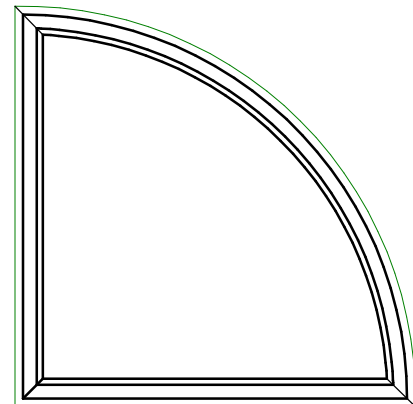

1/4 CIRCLE

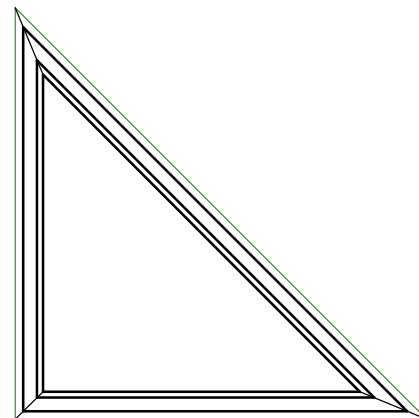

TRIANGLE

NOTES:

1. SEE SHEET 5 FOR DETAILED ANCHOR INSTALLATION REQUIREMENTS.
2. THRU FRAME - MASONRY, WOOD OR METAL OPENING.
THRU FIN - WOOD OPENING.
3. OVERALL SIZE MUST NOT EXCEED THE MAX. WIDTH AND HEIGHT OF
RECTANGULAR WINDOW ON SHEET 1.
4. ANCHOR SPACING FOR ARCHITECTURAL FLANGE AND FIN WINDOWS
MUST FOLLOW THE LAYOUTS SHOWN ON SHEET 5, WITH ANCHOR
SPACING MEASURED ALONG THE LENGTH OF THE PRODUCT.

INTERIOR

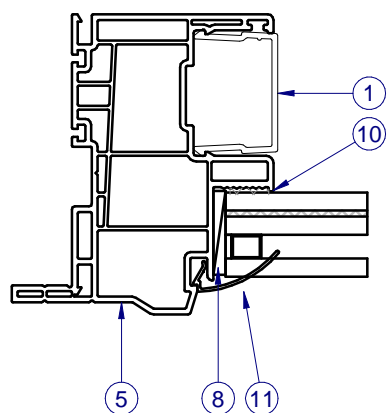

SECTION VIEW B-B

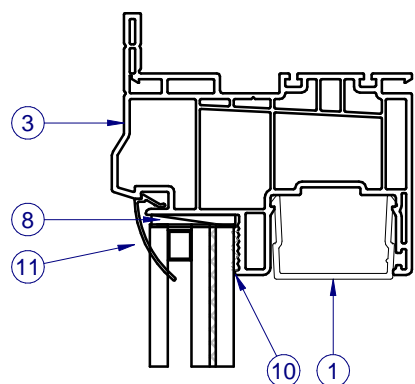
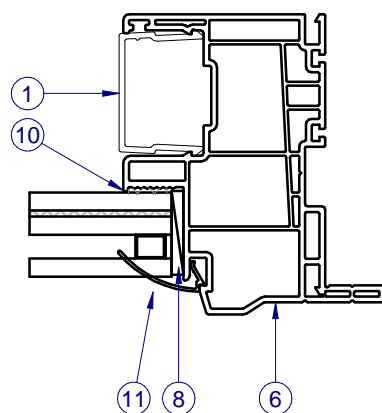

INTERIOR

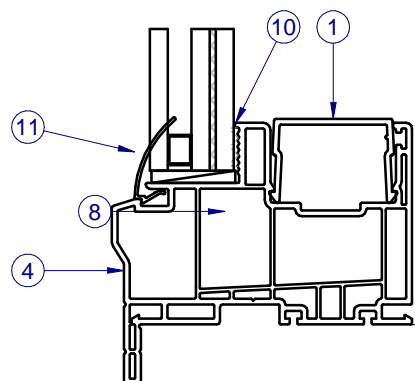

SECTION VIEW A-A

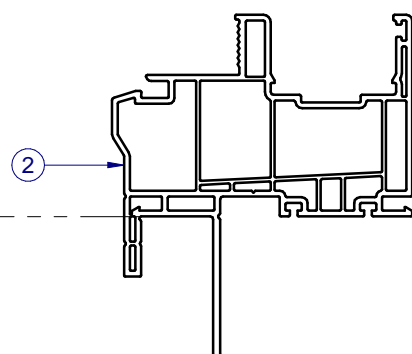

ALTERNATE FIN FRAME

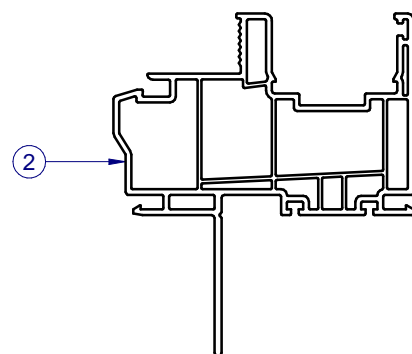

ALTERNATE FIN ONLY FRAME

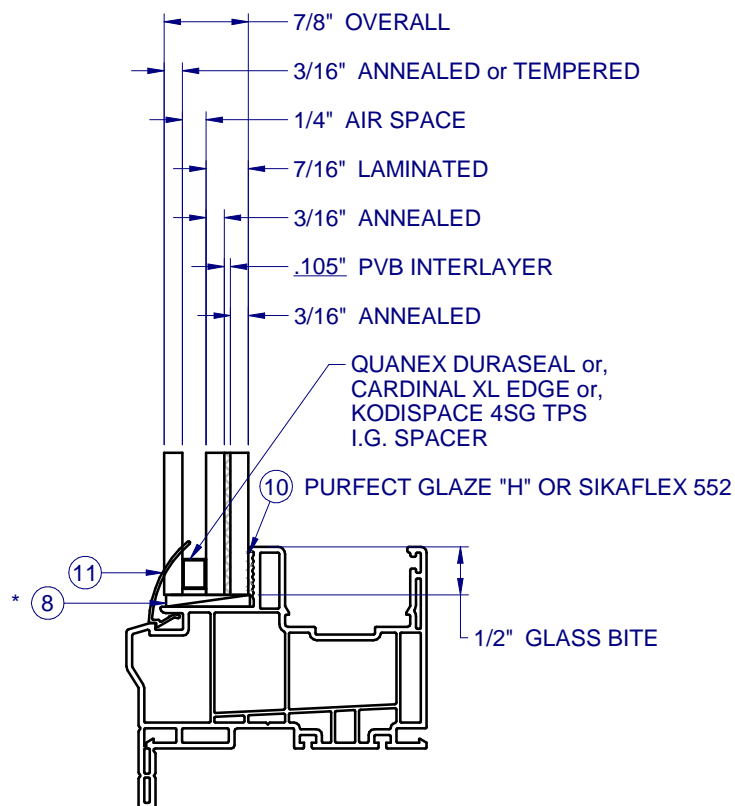

GLASS TYPE A
1:2

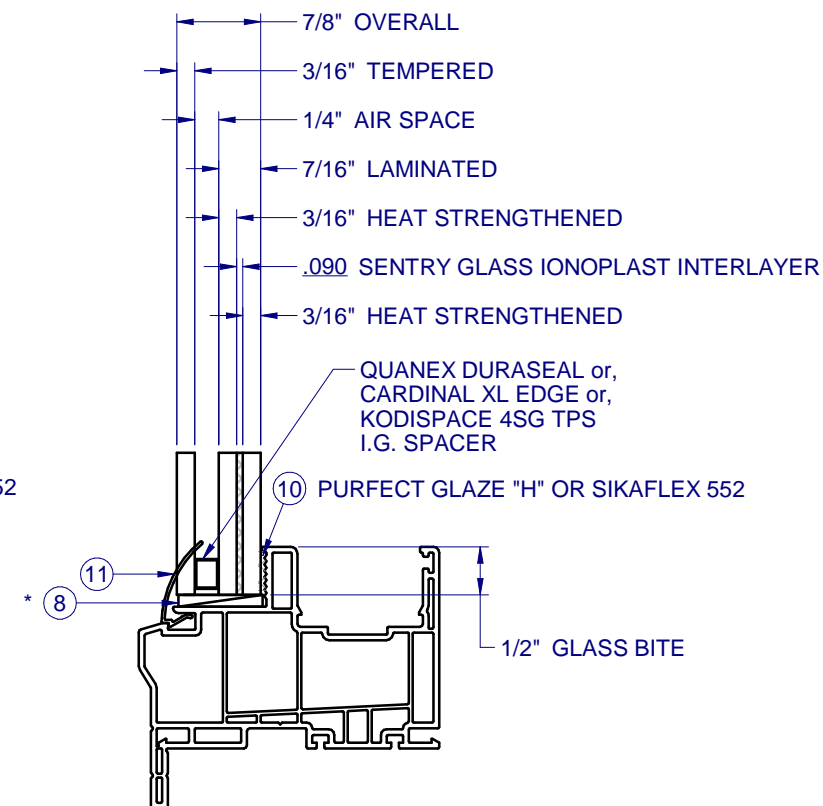

GLASS TYPE B
1:2

GLASS TYPE	DP	MAX SIZE
A	+/- 75	36 x 72
B	+/- 65	72 x 76
	+/- 67.5	

* SETTING BLOCKS PER FBC 2411.3.3.1

**515 PVC
FIXED WINDOW
IMPACT**

PROPRIETARY AND CONFIDENTIAL
 THE INFORMATION CONTAINED IN
 THIS DRAWING IS THE SOLE
 PROPERTY OF CUSTOM WINDOW
 SYSTEMS, INC. ANY
 REPRODUCTION IN PART OR AS A
 WHOLE WITHOUT THE WRITTEN
 PERMISSION OF CUSTOM WINDOW
 SYSTEMS, INC IS PROHIBITED.

FLORIDA APPROVAL NO.:
33563

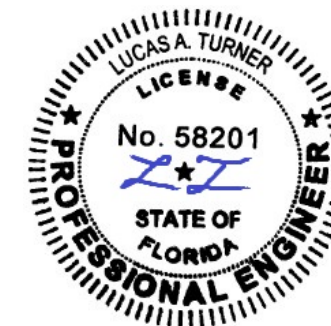

8/15/2023

LUCAS A. TURNER, P.E.
 FL PE # 58201
 Turner Engineering &
 Consulting, Inc.
 2428 Old Natchez Trc Trl
 Camden, TN 38320
 PH. 941-380-1574

SHEET DESCRIPTION:
SECTION VIEWS AND
GLAZING DETAIL

DRAWN BY: MCS	DATE: 8/9/2023
DWG #: PEL-433	REV.: A
SCALE: 1:2	SHEET 3 OF 6

PARTS LIST			
ITEM	PART #	DESCRIPTION	MATERIAL
1	H-6025	SASH STOP	PVC
2	H-6231	FIN FRAME	PVC
3	H-6222	FLANGE FRAME HEAD	PVC
4	H-6222	FLANGE FRAME SILL	PVC
5	H-6222	FLANGE FRAME LEFT JAMB	PVC
6	H-6222	FLANGE FRAME RIGHT JAMB	PVC
8	P-5612	SETTING BLOCK, .12 x 1 x 2	RUBBER
10	P-3438	PURFECT GLAZE "H" OR SIKAFLEX 552	
11	S-6237	GLAZING BEAD (7/8" O.A. I.G.)	PVC
12	GLASS	SEE SHEET 3	GLASS

LINE ITEMS NOT USED:
7, 9

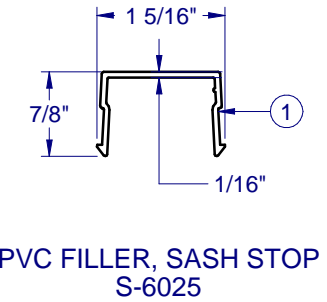
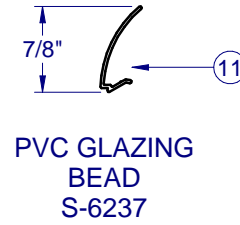
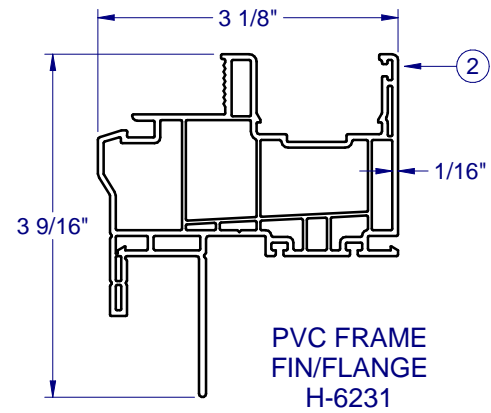
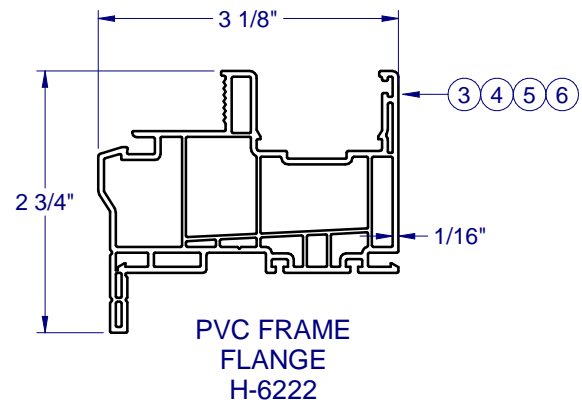

FRAME CORNER CONSTRUCTION

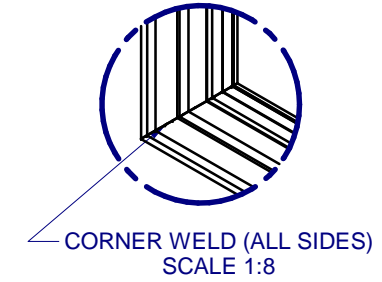

**515 PVC
FIXED WINDOW
IMPACT**

PROPRIETARY AND CONFIDENTIAL
THE INFORMATION CONTAINED IN
THIS DRAWING IS THE SOLE
PROPERTY OF CUSTOM WINDOW
SYSTEMS, INC. ANY
REPRODUCTION IN PART OR AS A
WHOLE WITHOUT THE WRITTEN
PERMISSION OF CUSTOM WINDOW
SYSTEMS, INC IS PROHIBITED.

FLORIDA APPROVAL NO.:
33563

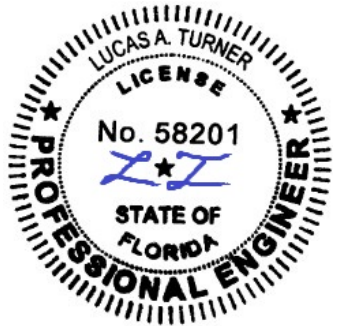

8/15/2023

LUCAS A. TURNER, P.E.
FL PE # 58201
Turner Engineering &
Consulting, Inc.
2428 Old Natchez Trc Trl
Camden, TN 38320
PH. 941-380-1574

SHEET DESCRIPTION:

BOM AND EXTRUSIONS

DRAWN BY: MCS	DATE: 8/9/2023
DWG #: PEL-433	REV.: A
SCALE: 1:2	SHEET 4 OF 6

**515 PVC
 FIXED WINDOW
 IMPACT**

PROPRIETARY AND CONFIDENTIAL
 THE INFORMATION CONTAINED IN
 THIS DRAWING IS THE SOLE
 PROPERTY OF CUSTOM WINDOW
 SYSTEMS, INC. ANY
 REPRODUCTION IN PART OR AS A
 WHOLE WITHOUT THE WRITTEN
 PERMISSION OF CUSTOM WINDOW
 SYSTEMS, INC IS PROHIBITED.

FLORIDA APPROVAL NO.:
 33563

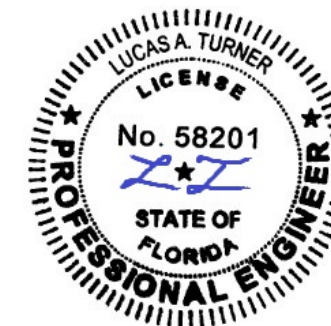

8/15/2023

LUCAS A. TURNER, P.E.
 FL PE # 58201
 Turner Engineering &
 Consulting, Inc.
 2428 Old Natchez Trc Trl
 Camden, TN 38320
 PH. 941-380-1574

SHEET DESCRIPTION:
**ANCHOR SCHEDULE AND
 NOTES**

DRAWN BY: MCS	DATE: 8/9/2023
DWG #: PEL-433	REV.: A
SCALE: 1:20	SHEET 5 OF 6

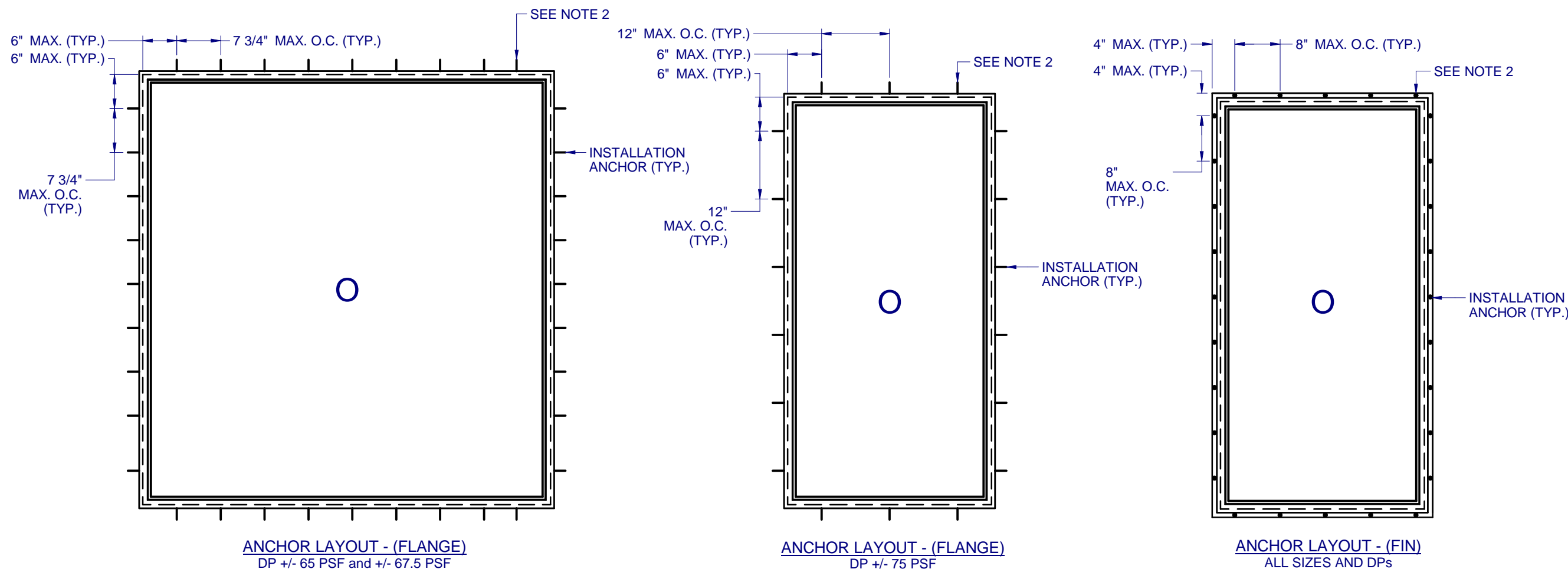

NOTES:

1. INSTALL ONE ANCHOR AT EACH INSTALLATION LOCATION. ANCHOR SPACING APPLIES TO ALL SHAPES (SEE SHEET 2) ALONG ALL FRAME EDGES. SILL ANCHOR SPACING SAME AS HEAD.
2. SHIM AS REQ AT EACH INSTALLATION ANCHOR USING LOAD BEARING SHIMS. MAX. ALLOWABLE SHIM STACK TO BE 1/4". USE SHIMS WHERE SPACE GREATER THAN 1/16" IS PRESENT. LOAD BEARING SHIMS SHALL BE CONSTRUCTED OF HIGH DENSITY PLASTIC OR BETTER. WOOD SHIMS ARE NOT ALLOWED.
3. ANCHOR TYPE, SIZE, SPACING AND EMBEDMENT SHALL BE AS SPECIFIED IN THESE DRAWINGS, SEE TABLE 1, SHEET 6.
4. ALL INSTALLATION ANCHORS MUST BE MADE OF OR PROTECTED WITH A CORROSION RESISTANT MATERIAL OR COATING. DISSIMILAR METALS OR MATERIALS IN CONTACT WITH PRESSURE TREATED WOOD MUST BE PROTECTED TO PREVENT REACTION.
5. INSTALLATION ANCHORS SHALL BE IN ACCORDANCE WITH ANCHOR MANUFACTURER'S INSTALLATION INSTRUCTIONS, AND ANCHORS SHALL NOT BE USED IN SUBSTRATES WITH STRENGTHS LESS THAN THE MINIMUM SPECIFIED IN TABLE 1, SHEET 6.
6. ANCHOR EMBEDMENT TO SUBSTRATE SHALL BE BEYOND WALL DRESSING OR STUCCO. FOR CONCRETE/CMU OPENINGS, EMBEDMENT SHALL BE BEYOND WOOD BUCKS, IF USED, INTO SUBSTRATE. INSTALLATIONS TO SOLID CONCRETE OR GROUT-FILLED CMU MAY INCLUDE BUT DO NOT REQUIRE 1X WOOD BUCKS BETWEEN THE PRODUCT AND SUBSTRATE. INSTALLATIONS TO HOLLOW CMU REQUIRE THE USE OF 1X BUCKS BETWEEN THE PRODUCT AND SUBSTRATE.
7. A MINIMUM CENTER-TO-CENTER SPACING SHALL BE MAINTAINED BETWEEN ALL FASTENERS: 3-9/16" FOR MASONRY, 1" FOR WOOD AND METAL.
8. WOOD OR MASONRY OPENINGS, BUCKS AND BUCK FASTENERS SHALL BE PROPERLY DESIGNED BY THE ARCHITECT OR ENGINEER OF RECORD AND INSTALLED TO TRANSFER WIND LOADS TO THE STRUCTURE. SUBSTRATES SHALL MEET THE MINIMUM STRENGTH REQUIREMENTS AS SHOWN IN TABLE 1, SHEET 6. CONCRETE AND MASONRY SUBSTRATES MAY NOT BE CRACKED.
9. SEALING AND FLASHING STRATEGIES FOR OVERALL WATER RESISTANCE OF INSTALLATION SHALL BE DONE BY OTHERS FOLLOWING THE CURRENT VERSION OF THE REFERENCE DOCUMENTS: FMA/AAMA 100(FIN WINDOWS), FMA/AAMA 200(FLANGE WINDOWS), FMA/WDMA 250(BOX WINDOWS), FMA/AAMA/WDMA 300(EXTERIOR DOORS)

**515 PVC
 FIXED WINDOW
 IMPACT**

PROPRIETARY AND CONFIDENTIAL
 THE INFORMATION CONTAINED IN THIS DRAWING IS THE SOLE PROPERTY OF CUSTOM WINDOW SYSTEMS, INC. ANY REPRODUCTION IN PART OR AS A WHOLE WITHOUT THE WRITTEN PERMISSION OF CUSTOM WINDOW SYSTEMS, INC IS PROHIBITED.

FLORIDA APPROVAL NO.:
 33563

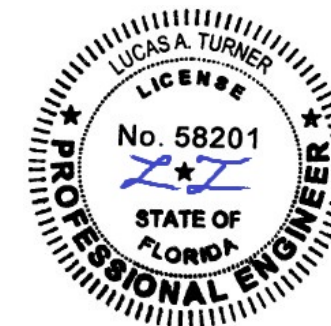

8/15/2023
 LUCAS A. TURNER, P.E.
 FL PE # 58201
 Turner Engineering & Consulting, Inc.
 2428 Old Natchez Trc Trl
 Camden, TN 38320
 PH. 941-380-1574

SHEET DESCRIPTION:

INSTALLATION DETAILS

DRAWN BY:	DATE:
MCS	8/9/2023
DWG #:	REV.:
PEL-433	A
SCALE:	SHEET
1:2	6 OF 6

TYPICAL HEAD ANCHORAGE

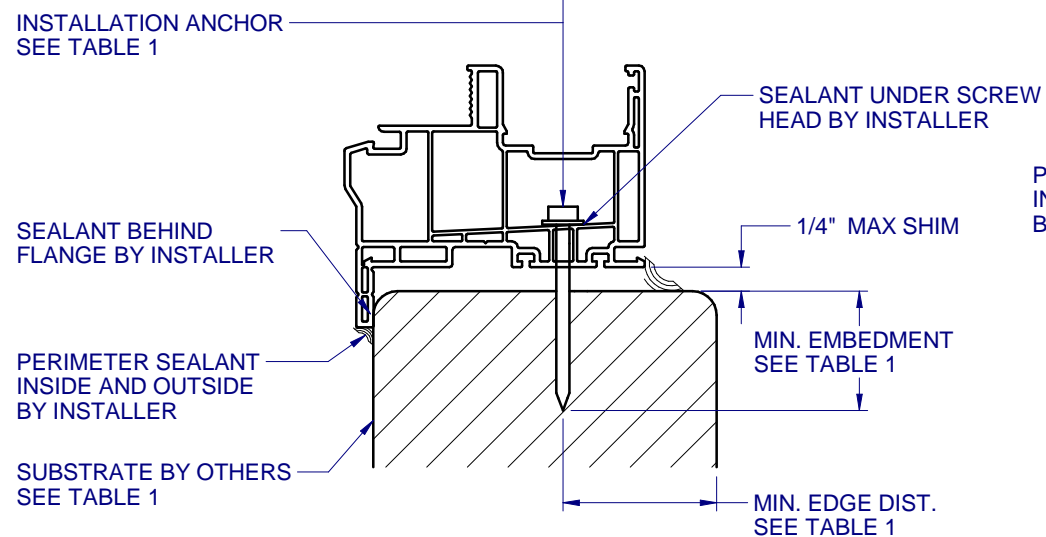
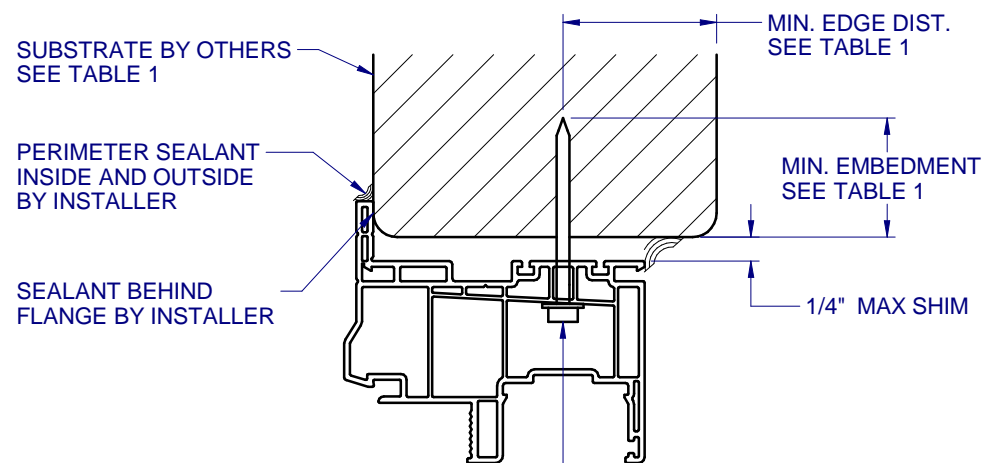

A
 6 VERTICAL SECTION
 TYPICAL SILL ANCHORAGE

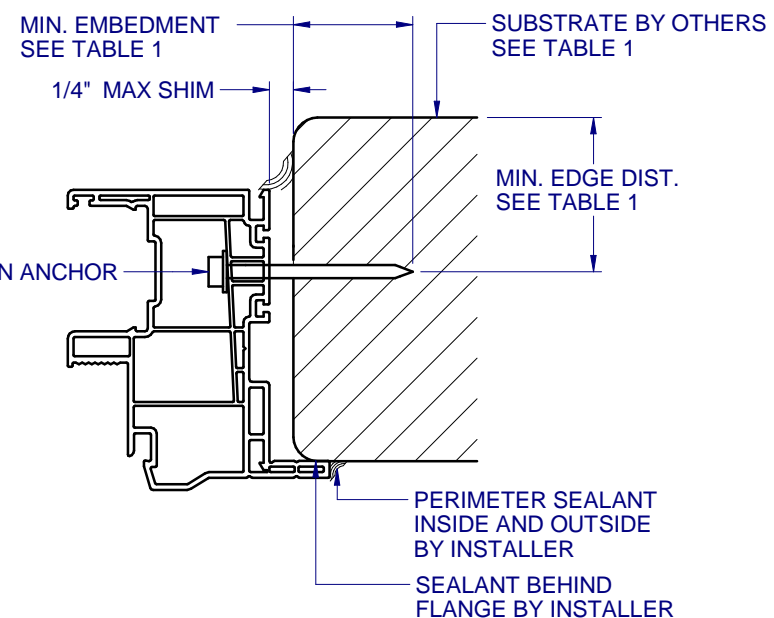

B
 6 HORIZONTAL SECTION
 TYPICAL JAMB ANCHORAGE

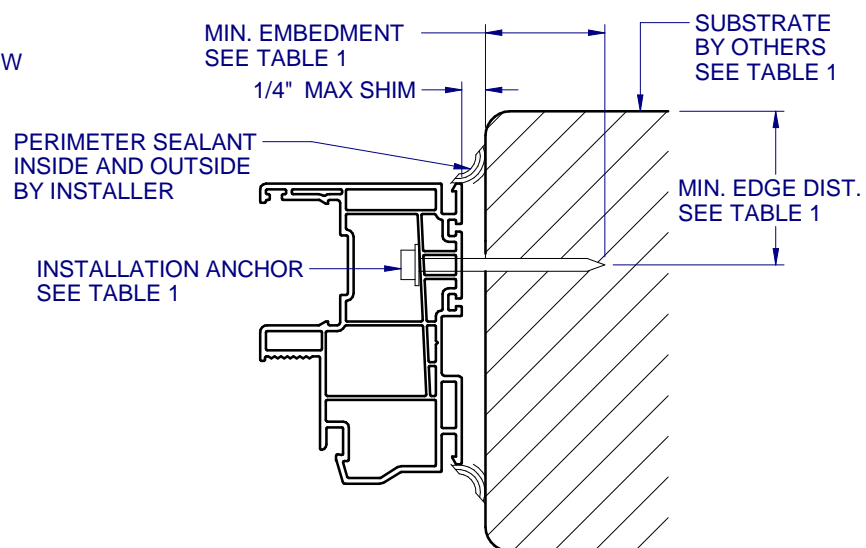

D
 6 HORIZONTAL SECTION
 BOX FRAME INSTALLATION
 HEAD AND SILL SIMILAR FOR BOX INSTALLATION

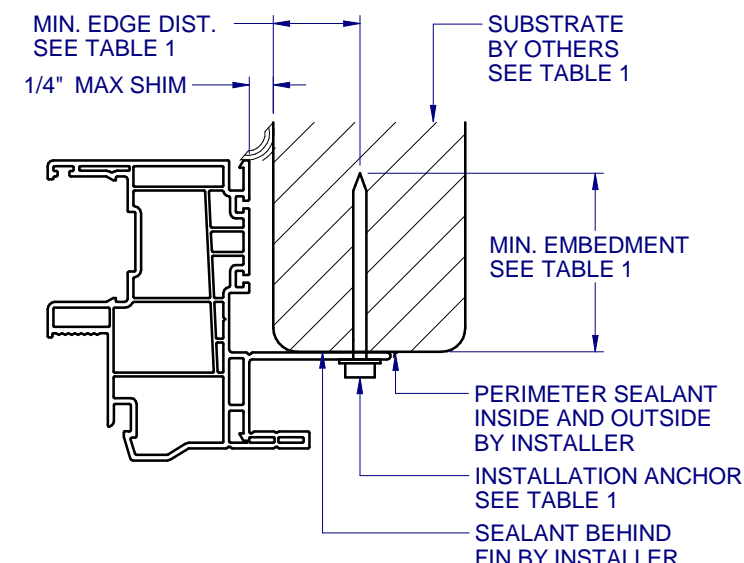

C
 6 HORIZONTAL SECTION
 TYPICAL FIN ANCHORAGE
 HEAD AND SILL SIMILAR FOR FIN INSTALLATION

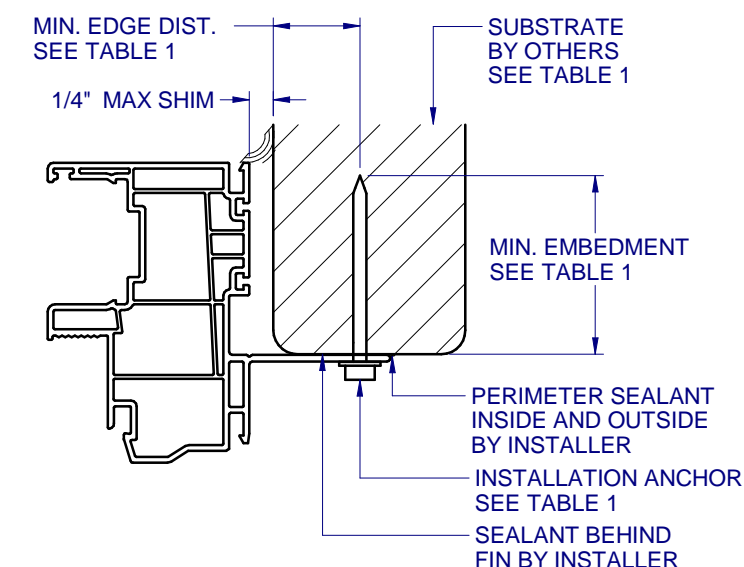

E
 6 HORIZONTAL SECTION
 TYPICAL FIN ANCHORAGE
 HEAD AND SILL SIMILAR FOR FIN INSTALLATION

TABLE 1: APPROVED INSTALLATION FASTENERS

FRAME TYPE	SUBSTRATE TYPE	ANCHOR TYPE	MIN. EMBEDMENT	MIN. EDGE DIST.
FLANGE	CONCRETE (2.0 KSI MIN.)	3/16" ITW TAPCON	1-1/2"	1-1/8"
FLANGE	HOLLOW OR GROUT-FILLED CMU (117 PCF MIN.)	3/16" ITW TAPCON	1"	2"
FLANGE	CONCRETE (3.05 KSI MIN.)	3/16" DEWALT ULTRACON+	1-3/4"	1"
FLANGE	HOLLOW OR GROUT-FILLED CMU (ASTM C-90)	3/16" DEWALT ULTRACON+	1-3/4"	2-1/2"
FLANGE	2X MIN. SOUTHERN PINE (G=0.55)	3/16" ITW TAPCON OR DEWALT ULTRACON+	1-3/8"	7/8"
FLANGE	2X MIN. SOUTHERN PINE (G=0.55)	#10 WOOD SCREW	1-3/8"	7/8"
FLANGE	16 GAUGE (0.060") MIN. STEEL STUD (33 KSI YIELD MIN)	#10-16 HILTI KWIK-FLEX OR ITW TEKS SELF-DRILLING SCREW	FULL THREAD THRU 0.060"	7/16"
FLANGE	1/8" ALUM. (6063-T5 MIN.) OR 1/8" STEEL (33 KSI MIN.)	#10 GRADE 5 SELF-TAPPING / DRILLING SCREW	FULL THREAD THRU 0.125"	7/16"
FIN	2X MIN. SOUTHERN PINE (G=0.55)	#8 WOOD SCREW	1-1/2"	7/16"

FLANGE REMOVAL NOTE: PARTIALLY OR FULLY REMOVING THE FLANGE, UP TO AND INCLUDING A BOX-FRAME APPLICATION IS ACCEPTABLE PROVIDED:

- MIN. 1/4" FILLET OF CONSTRUCTION-GRADE ADHESIVE CAULK IS APPLIED INSIDE AND OUTSIDE, FULL PERIMETER, BY INSTALLER.
- PRODUCT ANCHORAGE IS IN ACCORDANCE WITH REQUIREMENTS AS SHOWN FOR FLANGE WINDOWS.