

DP RATING	LARGE & SMALL MISSILE IMPACT RESISTANT
SEE TABLE 1	

Rev.#	A
Date	08/17/23
Rev.	MINOR EDITORIAL UPDATES

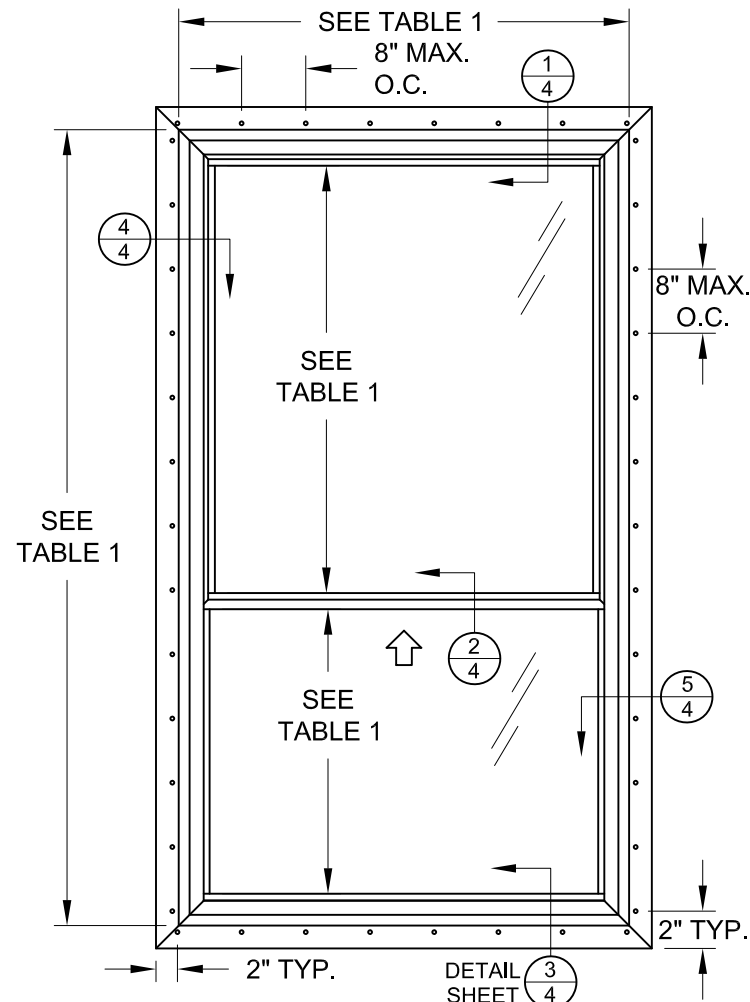

TYP. FIN ANCHOR LOCATIONS
(INTEGRAL FIN FRAME, ORIEL SHOWN, EQUAL-LITE SIMILAR)

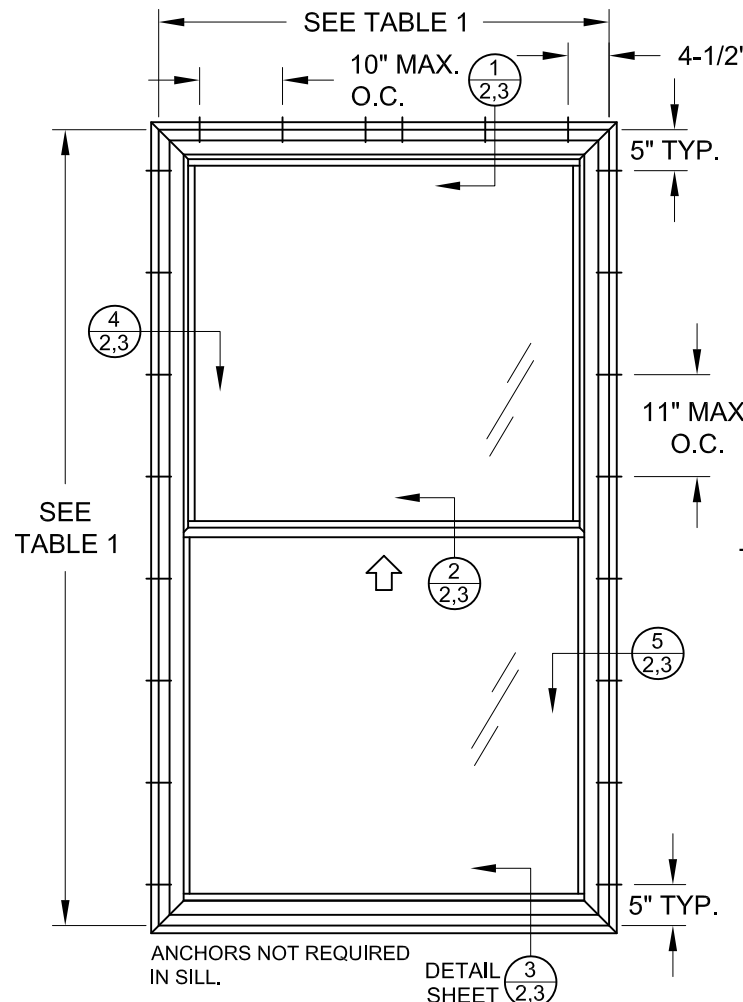

TYP. ANCHOR LOCATIONS
(FLANGED FRAME SHOWN, EQUAL-LEG SIM.)
(EQUAL-LITE SHOWN, ORIEL SIMILAR)

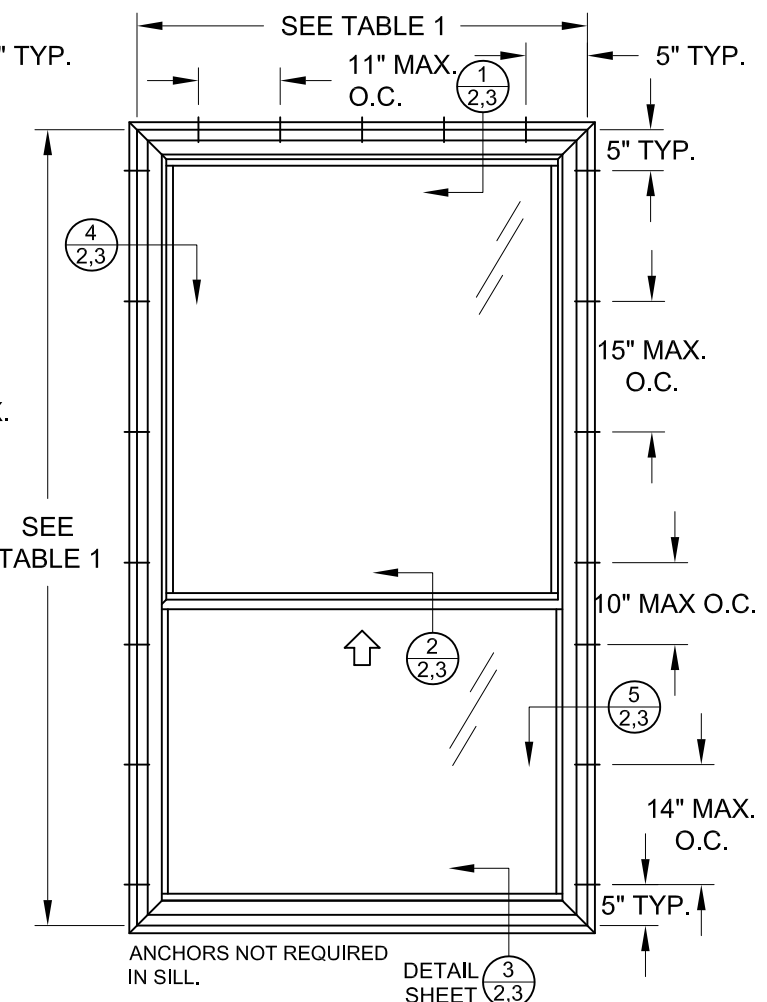

TYP. ANCHOR LOCATIONS
(FLANGED FRAME SHOWN, EQUAL-LEG SIM.)
(MAX. SIZE ORIEL CONFIG.)

SH900V SINGLE HUNG, TILT WINDOW, IMPACT RESISTANT, NON-HVHZ, FLANGE, EQUAL-LEG & FIN FRAMES

1) THIS PRODUCT HAS BEEN DESIGNED & TESTED TO COMPLY WITH THE REQUIREMENTS OF THE FLORIDA BUILDING CODE, EXCLUDING THE HIGH VELOCITY HURRICANE ZONE (HVHZ).

2) SHUTTERS ARE NOT REQUIRED WHEN USED IN WIND-BORNE DEBRIS REGIONS.

3) MASONRY ANCHORS MAY BE USED INTO WOOD. ALL WOOD BUCKS LESS THAN 1-1/2" THICK ARE TO BE CONSIDERED 1X INSTALLATIONS. 1X WOOD BUCKS ARE OPTIONAL IF UNIT IS INSTALLED DIRECTLY TO SUBSTRATE. WOOD BUCKS DEPICTED AS 2X ARE 1-1/2" THICK OR GREATER.

4) ANCHOR EMBEDMENT TO BASE MATERIAL SHALL BE BEYOND WALL DRESSING OR STUCCO. USE ANCHORS OF SUFFICIENT LENGTH.

5) MAX. 1/4" SHIMS ARE REQUIRED AT EACH ANCHOR LOCATION WHERE THE PRODUCT IS NOT FLUSH TO THE SUBSTRATE. USE SHIMS CAPABLE OF TRANSFERRING APPLIED LOADS.

TABLE 1: DESIGN PRESSURES

Buck Width	Buck Height	Max. Sash DLO Size (Width x Height)	Max. Fixed DLO Size (Width x Height)	Configuration	Frame Type	Glass Type	Design Pressure	
							(+) psf	(-) psf
54"	76"	47.25" x 34.38"	49.75" x 34.5"	Equal-lite	All	1	55.0	65.0
40"	48"	33.25" x 20.38"	35.75" x 20.5"	Equal-lite	Flange, Equal-Leg	2	65.0	85.0
54"	92"	47.25" x 34.19"	49.81" x 50.75"	Oriel	All	1 & 3	55.0	55.0

FOR SIZES NOT SHOWN, ROUND UP TO THE NEXT AVAILABLE WIDTH OR HEIGHT DIMENSION.

FOR GLASS TYPES, SEE SHEET 6.

6) THE ANCHORAGE METHODS SHOWN HAVE BEEN DESIGNED TO RESIST THE WIND LOADS CORRESPONDING TO THE REQUIRED DESIGN PRESSURE. THE 33-1/3% STRESS INCREASE HAS NOT BEEN USED IN THE DESIGN OF THIS PRODUCT. THE 1.6 LOAD DURATION FACTOR WAS USED FOR THE EVALUATION OF ANCHORS INTO WOOD. ANCHORS THAT COME INTO CONTACT WITH OTHER DISSIMILAR MATERIALS SHALL MEET THE REQUIREMENTS OF THE FLORIDA BUILDING CODE FOR CORROSION RESISTANCE.

7) FRAME FLANGES OR INTEGRAL FINNS MAY BE TRIMMED IN-FIELD TO CREATE AN EQUAL-LEG FRAME.

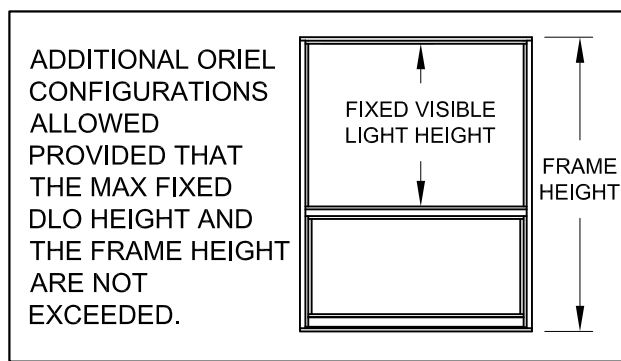

PREPARED BY A. LYNN MILLER 1070 TECHNOLOGY DRIVE N. VENICE, FL 34275 (941) 480-1600	REGISTRATION #29296 COPYRIGHT © 2023 PGT, INC., LIMITED LICENSE TO MAKE COPIES FOR PERMITTING.	04/14/23 Date	LOGAN YODER Drawn By	SH900V-FPA-LMI DWG No.
	VINYL SINGLE HUNG WINDOW (LM) Title	ELEVATION & GENERAL NOTES Sheet	1 OF 6 Sheet	SH900V Series Desc.

ANTHONY LYNN MILLER
 LICENSE
 No. 58705
 08/18/23
 STATE OF FLORIDA
 PROFESSIONAL ENGINEER
 A. LYNN MILLER, P.E.
 P.E.# 58705

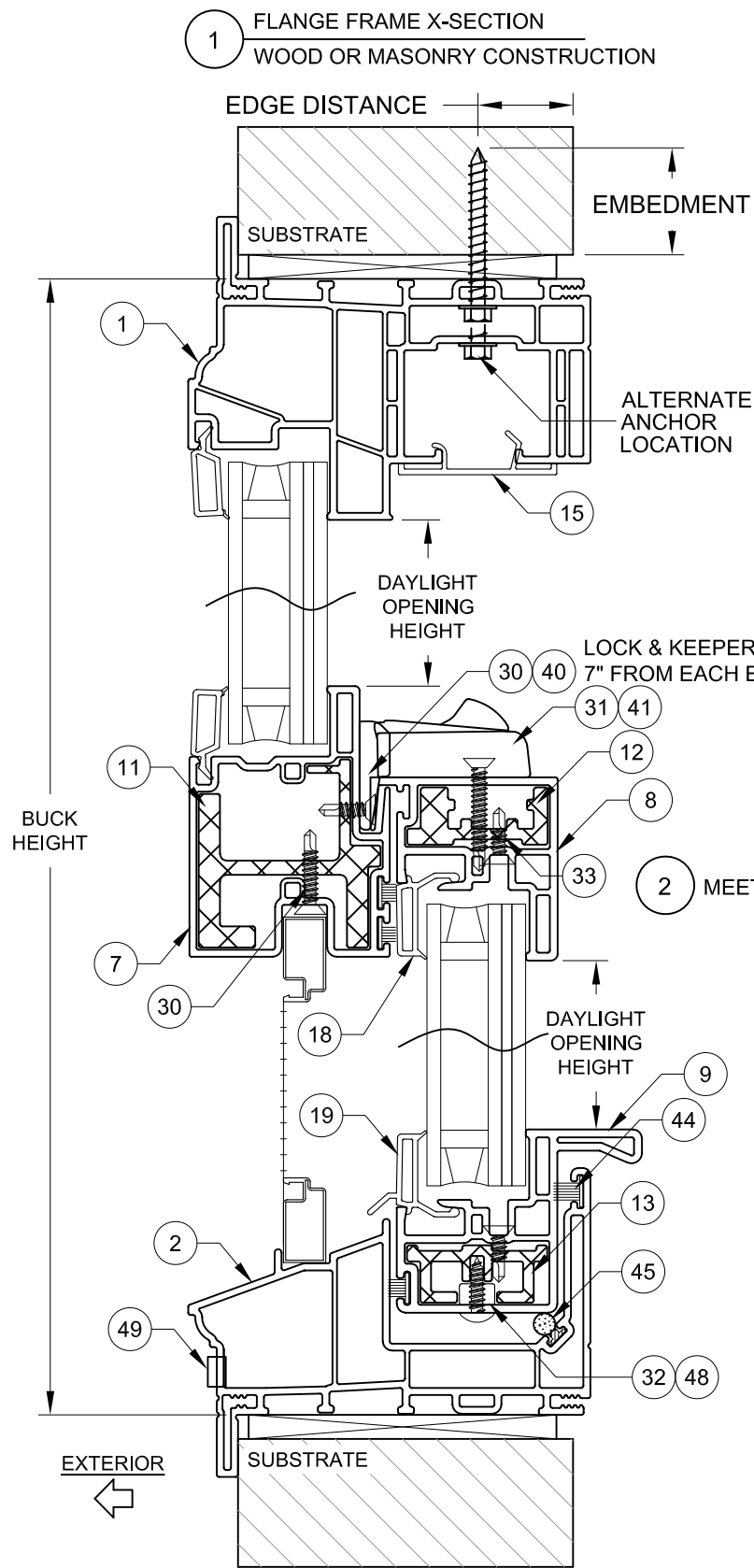

1 FLANGE FRAME X-SECTION
WOOD OR MASONRY CONSTRUCTION

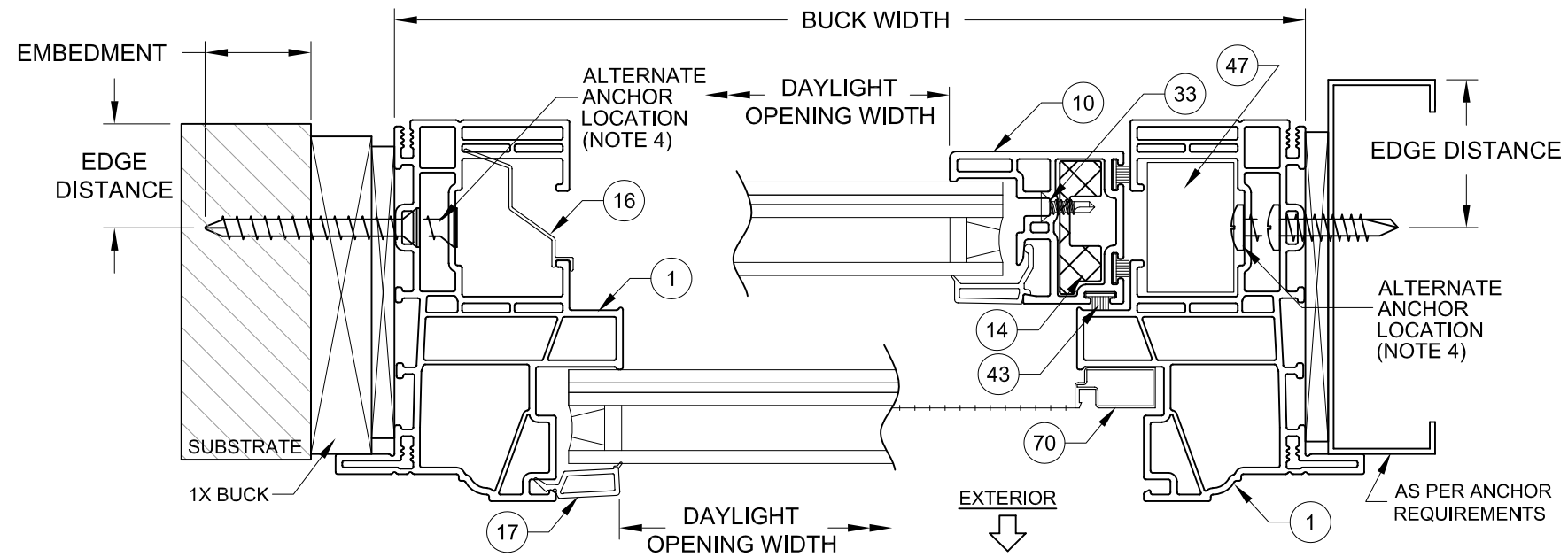

4 FLANGE FRAME X-SECTION
USING 1X BUCK

5 FLANGE FRAME X-SECTION
STEEL STUD CONSTRUCTION

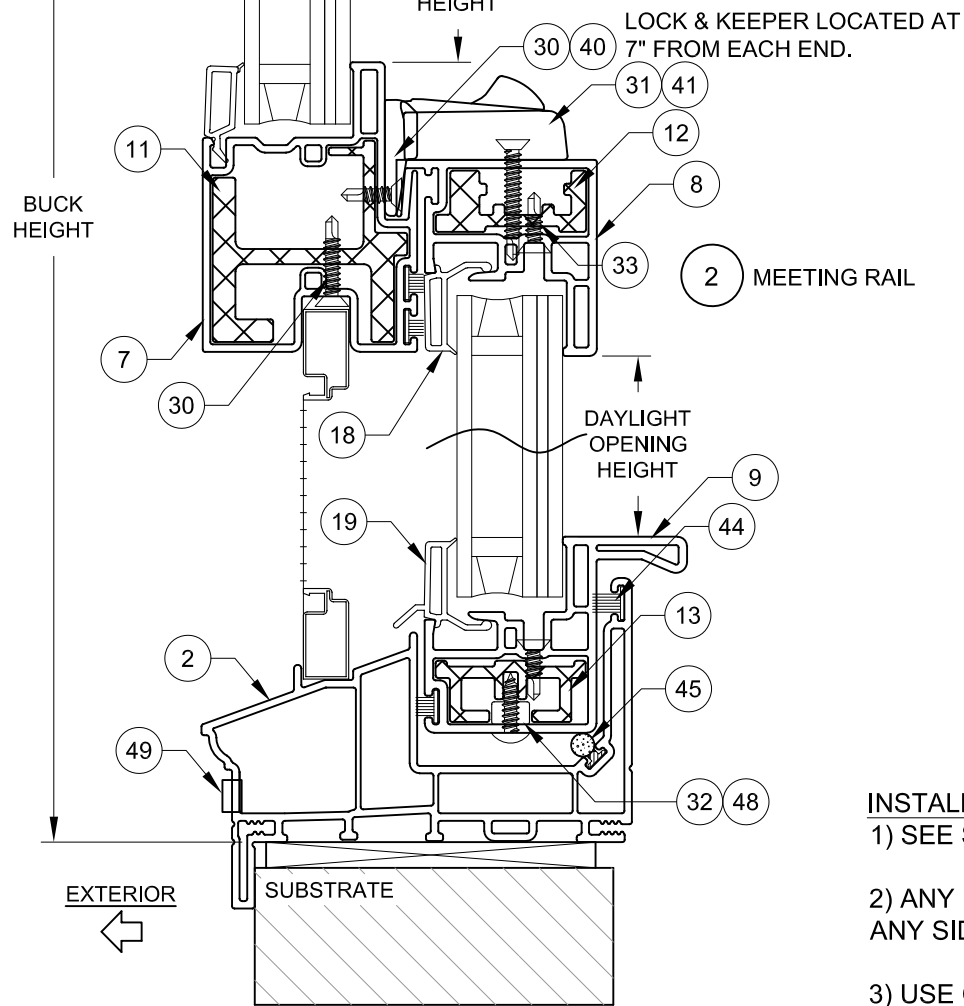

2 MEETING RAIL

TABLE 2: INSTALLATION ANCHORS

Anchor	Substrate	Minimum Edge Distance	Minimum Embedment
#10 or #12 Steel or 410 SS Screw	Southern Pine (SG = .55)	1/2"	1-3/8"
	Aluminum, 6063-T5 min.	5/16"	0.050"
	Steel Stud, Gr. 33 min.	5/16"	0.045" (20 Ga)
	A36 Steel	5/16"	0.050"
3/16" Steel Ultracon+	Concrete (min. 2.9 ksi)	1"	1-3/4"
	UngROUTED CMU, (ASTM C-90)	1-1/16"	1-1/4"
1/4" Steel Ultracon+	Southern Pine (SG = .55)	1"	1-3/8"
	Concrete (min. 3.0 ksi)	1"	1-3/8"
	UngROUTED CMU, (ASTM C-90)	1"	1-1/4"
	Southern Pine (SG = .55)	1"	1-3/8"

- 1) ANCHOR MUST EXTEND A MINIMUM OF 3 THREADS BEYOND ANY METAL SUBSTRATE.
- 2) "UNGROUTED CMU" VALUES MAY BE USED FOR GROUDED CMU APPLICATIONS.
- 3) ALL ANCHOR HEAD TYPES ARE APPLICABLE.

INSTALLATION NOTES:

- 1) SEE SHEET 1 FOR ANCHOR SPACING REQUIREMENTS.
- 2) ANY INSTALLATION OPTION SHOWN (2X BUCK OR WOOD FRAMING, 1X BUCK, DIRECT TO MASONRY, STEEL STUD) MAY BE USED ON ANY SIDE OF THE WINDOW.
- 3) USE ONLY SUBSTRATE APPROPRIATE ANCHORS LISTED IN ANCHOR TABLE 2. FOLLOW EMBEDMENT AND EDGE DISTANCE LIMITS. MAX. SHIM THICKNESS TO BE 1/4".
- 4) MAXIMUM DESIGN PRESSURE LIMITED TO +/- 55 PSF FOR ALTERNATE ANCHOR LOCATION.

PREPARED BY A. LYNN MILLER
1070 TECHNOLOGY DRIVE
N. VENICE, FL 34275
(941) 480-1600

REGISTRATION #29296
COPYRIGHT © 2023 PGT, INC., LIMITED LICENSE
TO MAKE COPIES FOR PERMITTING.

04/14/23
Date

LOGAN YODER
By

SH900V-FPA-LMI
No.

2 OF 6
DWG

SH900V
Sheet

VINYL SINGLE HUNG WINDOW (LM)
Title

FLANGE INSTALL SECTION VIEWS
Desc.

ANTHONY LYNN MILLER
LICENSE
No. 58705
A. Lynn Miller
08/18/23
STATE OF
FLORIDA
PROFESSIONAL ENGINEER
A. LYNN MILLER, P.E.
P.E.# 58705

Rev.# 08/17/23
Date
MINOR EDITORIAL UPDATES
Rev.

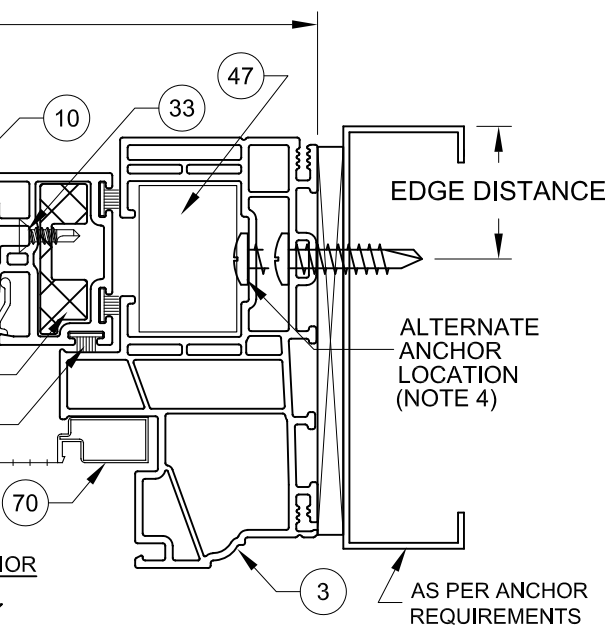
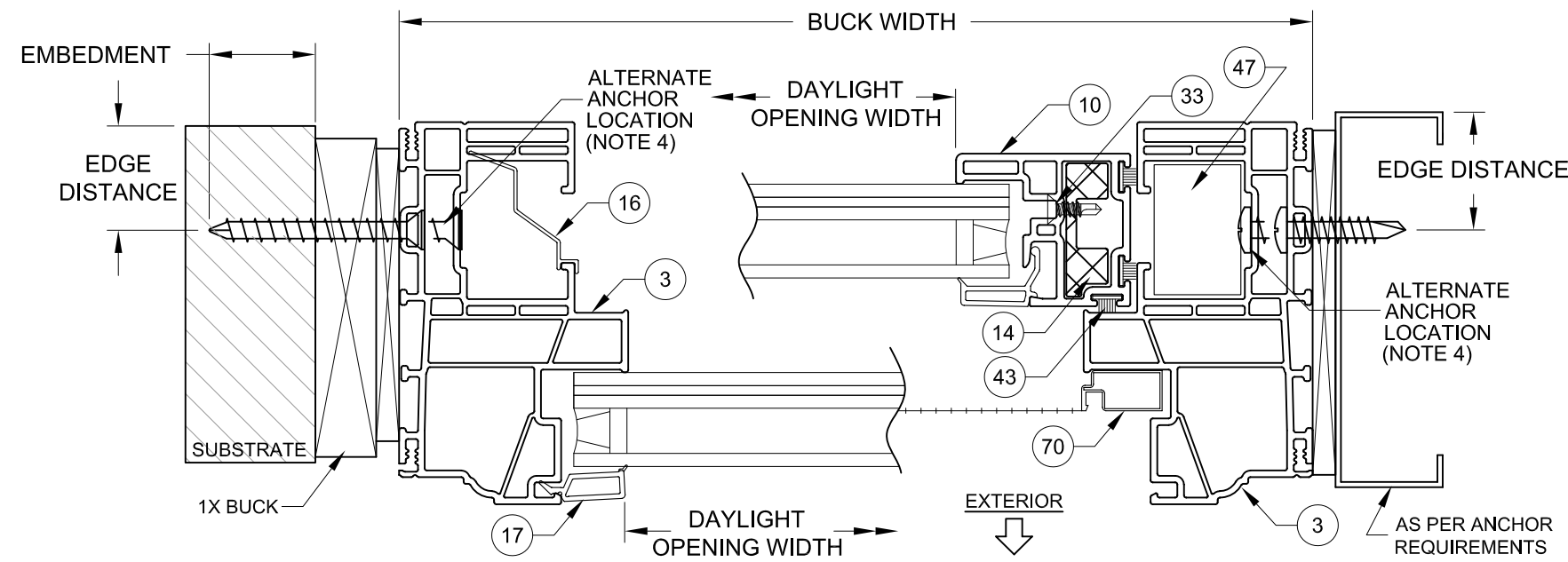
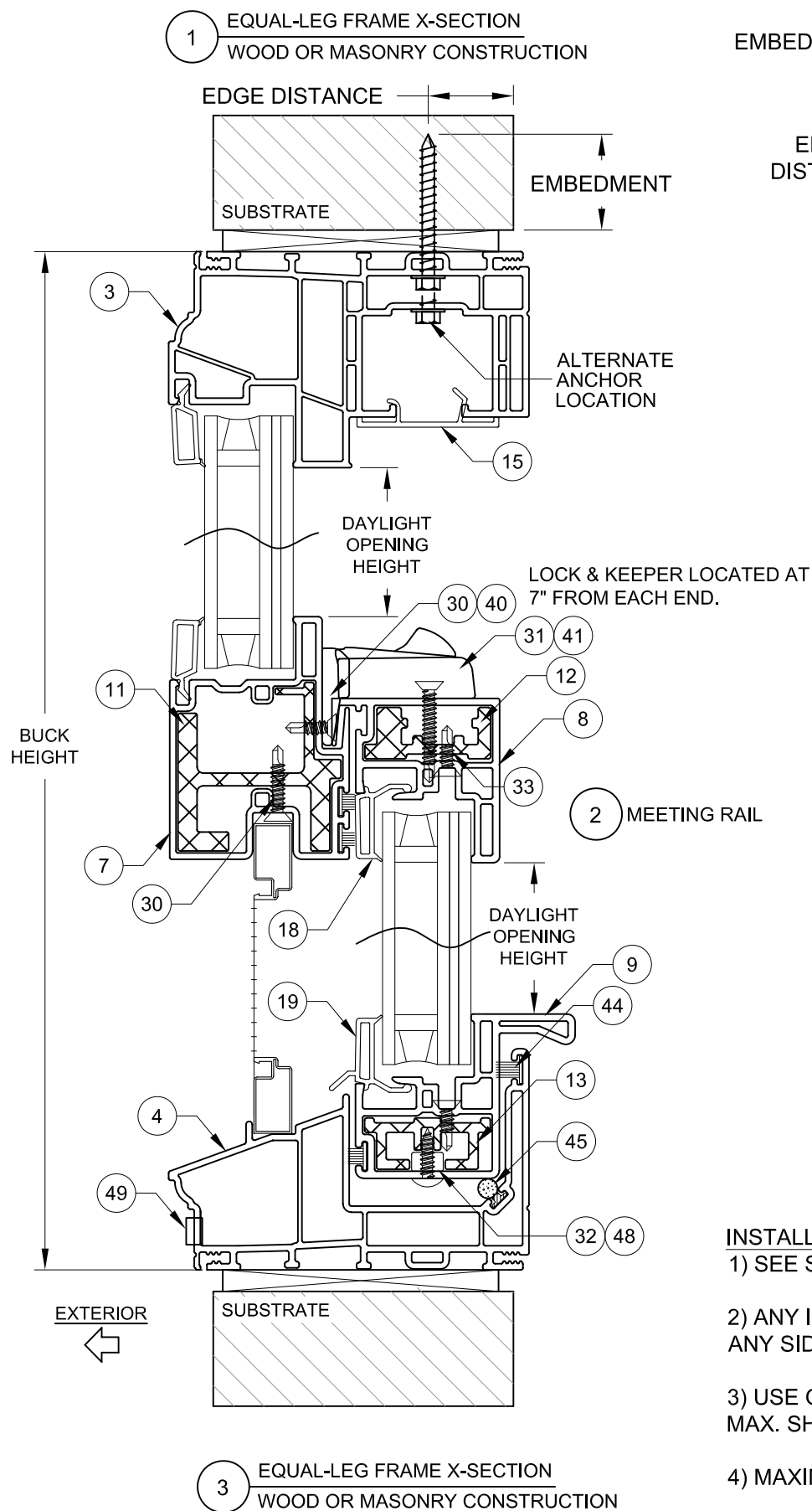

4 EQUAL-LEG FRAME X-SECTION USING 1X BUCK

5 EQUAL-LEG FRAME X-SECTION STEEL STUD CONSTRUCTION

TABLE 3: INSTALLATION ANCHORS

Anchor	Substrate	Minimum Edge Distance	Minimum Embedment
#10 or #12 Steel or 410 SS Screw	Southern Pine (SG = .55)	1/2"	1-3/8"
	Aluminum, 6063-T5 min.	5/16"	0.050"
	Steel Stud, Gr. 33 min.	5/16"	0.045" (20 Ga)
	A36 Steel	5/16"	0.050"
3/16" Steel Ultracon+	Concrete (min. 2.9 ksi)	1"	1-3/4"
	UngROUTED CMU, (ASTM C-90)	1-1/16"	1-1/4"
	Southern Pine (SG = .55)	1"	1-3/8"
1/4" Steel Ultracon+	Concrete (min. 3.0 ksi)	1"	1-3/8"
	UngROUTED CMU, (ASTM C-90)	1"	1-1/4"
	Southern Pine (SG = .55)	1"	1-3/8"

- 1) ANCHOR MUST EXTEND A MINIMUM OF 3 THREADS BEYOND ANY METAL SUBSTRATE.
- 2) "UNGROUTED CMU" VALUES MAY BE USED FOR GROUDED CMU APPLICATIONS.
- 3) ALL ANCHOR HEAD TYPES ARE APPLICABLE.

INSTALLATION NOTES:

- 1) SEE SHEET 1 FOR ANCHOR SPACING REQUIREMENTS.
- 2) ANY INSTALLATION OPTION SHOWN (2X BUCK OR WOOD FRAMING, 1X BUCK, DIRECT TO MASONRY, STEEL STUD) MAY BE USED ON ANY SIDE OF THE WINDOW.
- 3) USE ONLY SUBSTRATE APPROPRIATE ANCHORS LISTED IN ANCHOR TABLE 3. FOLLOW EMBEDMENT AND EDGE DISTANCE LIMITS. MAX. SHIM THICKNESS TO BE 1/4".
- 4) MAXIMUM DESIGN PRESSURE LIMITED TO +/- 55 PSF FOR ALTERNATE ANCHOR LOCATION.

Rev.# 08/17/23
Date
MINOR EDITORIAL UPDATES
Rev.

PREPARED BY A. LYNN MILLER
1070 TECHNOLOGY DRIVE
N. VENICE, FL 34275
(941) 480-1600

REGISTRATION #29296
COPYRIGHT © 2023 PGT, INC., LIMITED LICENSE
TO MAKE COPIES FOR PERMITTING.

04/14/23
Date

LOGAN YODER
By

SH900V-FPA-LMI
No.

3 OF 6
DWG

SH900V
Sheet

VINYL SINGLE HUNG WINDOW (LM)
Date

EQUAL-LEG INSTALLATION
SECTION VIEWS
Desc.

Impact Resistant Windows & Doors
CGI WINDOWS AND DOORS
3780 W. 104TH STREET
HIALEAH, FL 33018

ANTHONY LYNN MILLER
LICENSE
No. 58705
08/18/23
STATE OF FLORIDA
PROFESSIONAL ENGINEER
A. LYNN MILLER, P.E.
P.E.# 58705

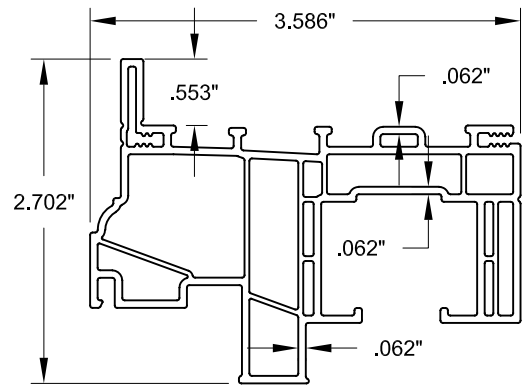

① HEAD & JAMB, W/FLANGE

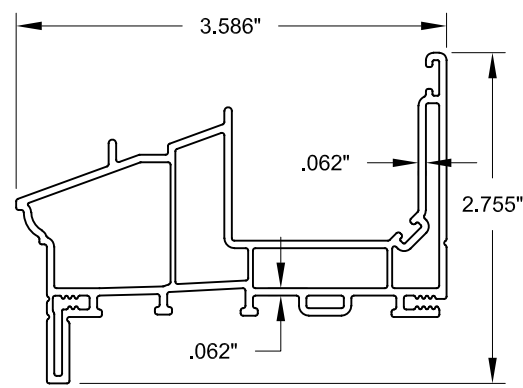

② SILL, W/FLANGE

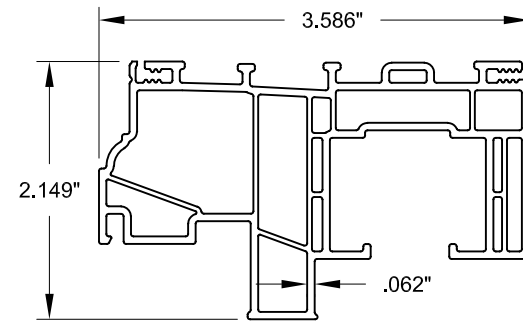

③ HEAD & JAMB, EQUAL LEG

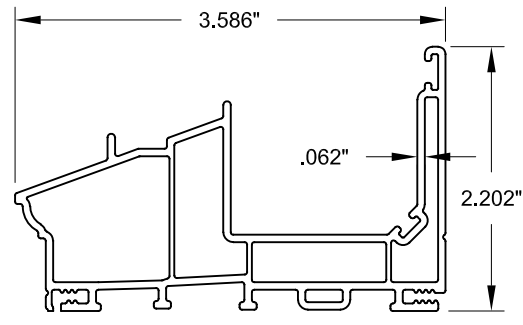

④ SILL, EQUAL LEG

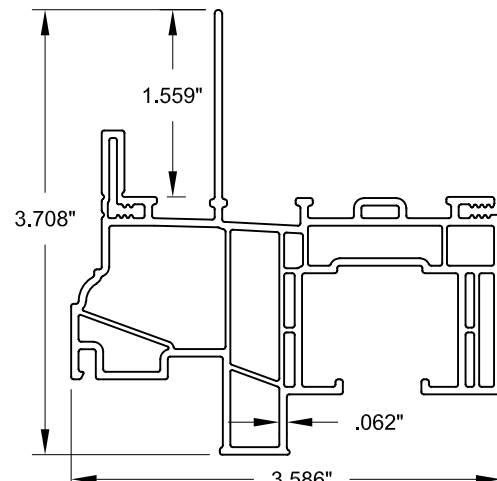

⑤ HEAD & JAMB, W/NAILING FIN

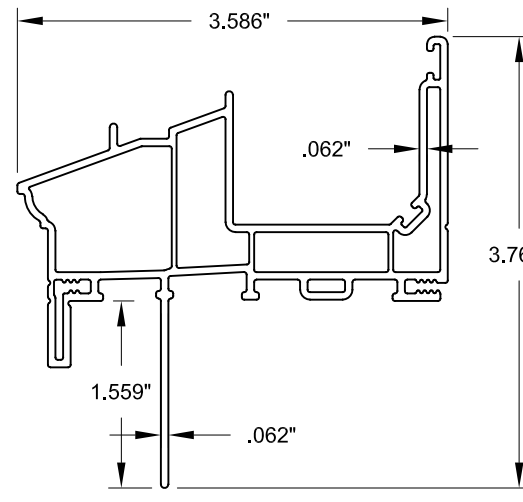

⑥ SILL, W/NAILING FIN

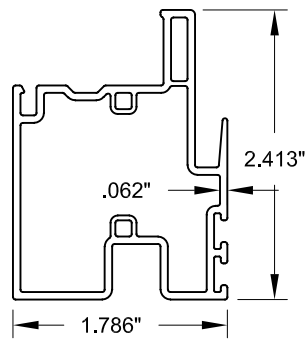

⑦ MEETING RAIL

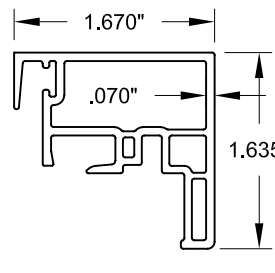

⑧ LOCK RAIL

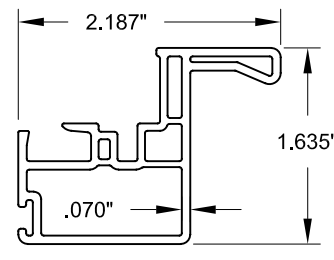

⑨ LIFT RAIL

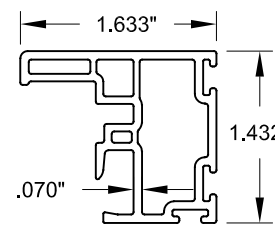

⑩ SASH STILE

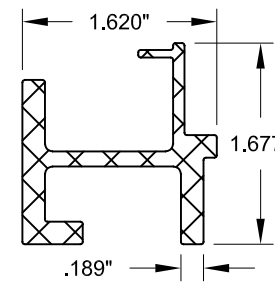

⑪ REINFORCEMENT (MEETING RAIL)

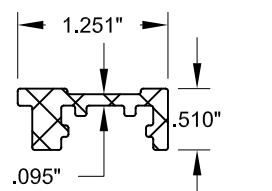

⑫ REINFORCEMENT (LOCK RAIL)

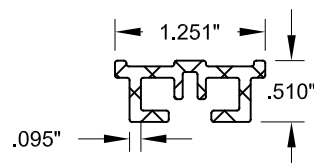

⑬ REINFORCEMENT (BOTTOM RAIL)

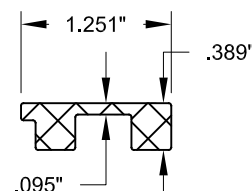

⑭ REINFORCEMENT (SASH STILE)

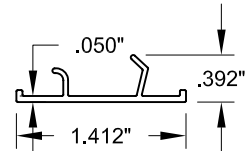

⑮ SASH STOP

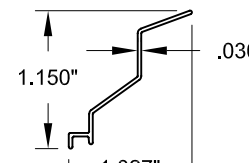

⑯ BALANCE COVER

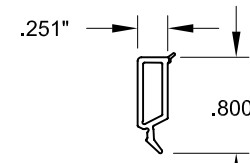

⑰ FIXED LITE GLAZING BEAD

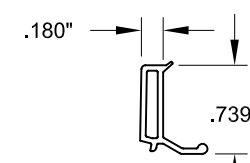

⑱ SASH GLAZING BEAD

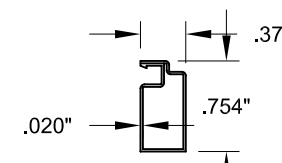

⑳ SCREEN FRAME

TABLE 5:

#	Part #	Description	Material
1	9465	Head & Jamb, w/Flange	PVC
2	9469	Sill, w/Flange	PVC
3	9465	Head & Jamb, Equal Leg	PVC
4	9469	Sill, Equal Leg	PVC
5	9455	Head & Jamb, w/Nailing Fin	PVC
6	9459	Sill, w/Nailing Fin	PVC
7	9477	Meeting Rail	PVC
8	9485	Lock Rail	PVC
9	9476	Sash Lift Rail	PVC
10	9438	Sash Stiles	PVC
11	6166	Reinf. - Meeting Rail	6063-T5
12	6165	Reinf. - Lock Rail	6063-T5
13	6163	Reinf. - Lift Rail	6063-T5
14	6164	Reinf. - Stiles	6063-T5
15	9473	Sash Stop	PVC
16	9468	Balancer Cover	PVC
17	9736	Fixed Lite Glazing Bead	PVC
18	9425	Sash Glazing Bead	PVC
30	1012	Screw, #6 x 3/4" PFH	Steel
31	1007	Screw, #6 x 1-1/8" PFH	Steel
32	1015	Screw, #8 x 1/2" PTRUSS	Steel
33	1003	Screw, #6 x 1/2" PFH	Steel
40	8096	Keeper	Zinc
41		Lock	
42	8121	MR Backing Plate	SS
43	4006	WSTP, .270" x .220" Polyfin	
44	4008	WSTP, .270" x .320" Polyfin	
45	4012	WSTP, Bulb Vinyl, .187" x .300"	Steel
46	8205/8206	Tilt Latch, L&R	Zinc
47		Balance	
48	8148	Pivot Bar	SS
49	8223	Weep Cover	Nylon
60		RGS 7700, Pecora 895, SikaFlex 552, Dow 791, 983 or 995	
61		Insulated Glass Spacer	
62	7061	Setting Block, 1/8" x 7/8" x 2"	EPDM
70	6244	Screen Frame	Aluminum

THE APPROVED, RIGID PVC EXTERIOR EXTRUSIONS ARE TO BE PRODUCED BY EXTRUDERS' LICENSEES UNDER "AAMA CERTIFICATION PROGRAMS FOR RIGID PVC EXTRUSIONS".

PREPARED BY A. LYNN MILLER
1070 TECHNOLOGY DRIVE
N. VENICE, FL 34275
(941) 480-1600

REGISTRATION #29296
COPYRIGHT © 2023 PGT, INC., LIMITED LICENSE
TO MAKE COPIES FOR PERMITTING.

DATE: 04/14/23
BY: LOGAN YODER
SERIES: SH900V-FPA-LMI

CGI WINDOWS AND DOORS
3780 W. 104TH STREET
HIALEAH, FL 33018

VINYL SINGLE HUNG WINDOW (LM)
EXTRUSIONS & BOM

5 OF 6

SH900V

Impact Resistant Windows & Doors

CGI WINDOWS AND DOORS
3780 W. 104TH STREET
HIALEAH, FL 33018

ANTHONY LYNN MILLER
LICENSE
No. 58705
08/18/23
STATE OF FLORIDA
PROFESSIONAL ENGINEER
A. LYNN MILLER, P.E.
P.E.# 58705

Rev.# 08/17/23
Date
MINOR EDITORIAL UPDATES
Rev.

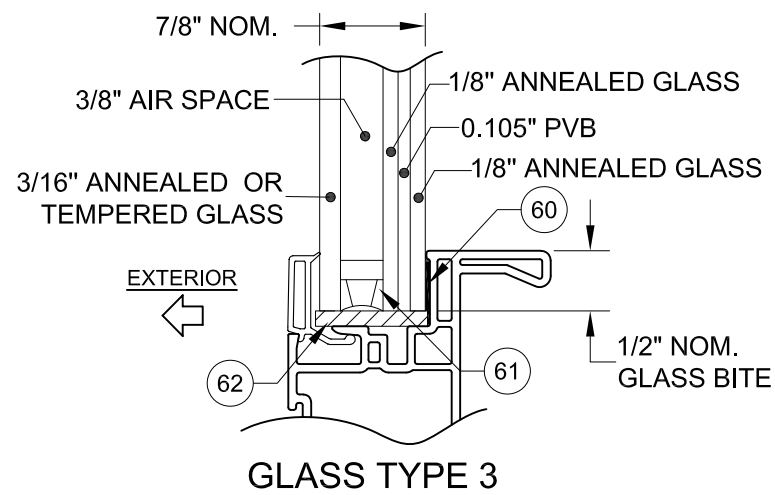
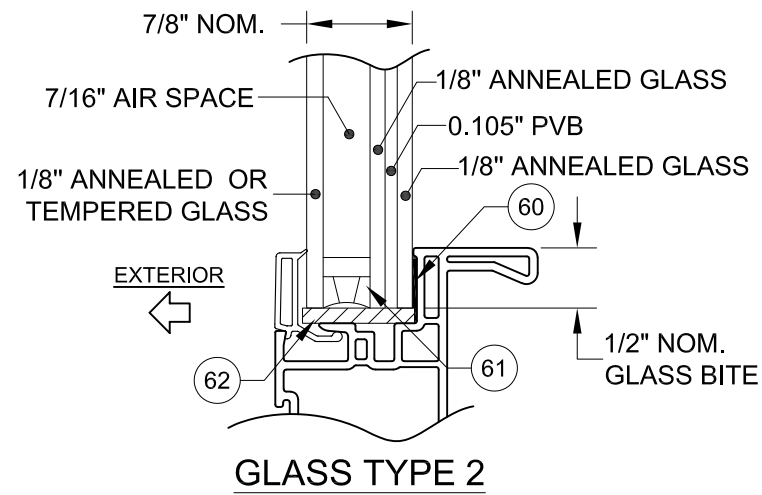
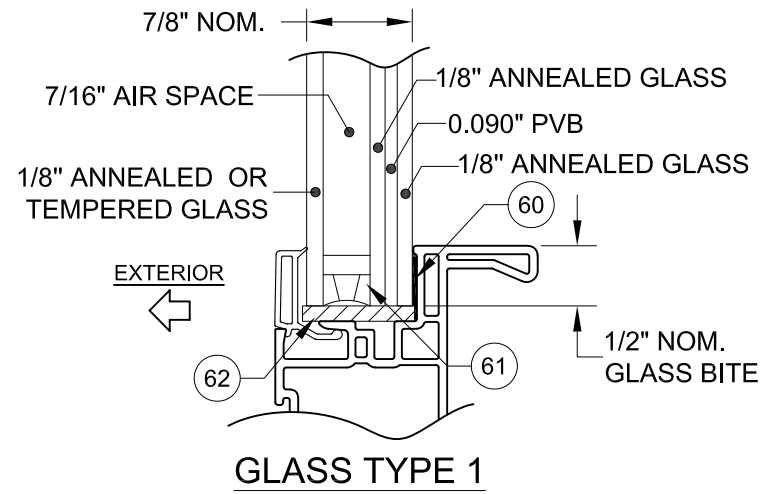

Rev. #	08/17/23
Date	08/17/23
Rev.	MINOR EDITORIAL UPDATES
	A

PREPARED BY A. LYNN MILLER 1070 TECHNOLOGY DRIVE N. VENICE, FL 34275 (941) 480-1600	REGISTRATION #29296	04/14/23	LOGAN YODER SH900V-FPA-LMI
	COPYRIGHT © 2023 PGT, INC., LIMITED LICENSE TO MAKE COPIES FOR PERMITTING.	Date	
Impact Resistant Windows & Doors CGI WINDOWS AND DOORS 3780 W. 104TH STREET HIALEAH, FL 33018	VINYL SINGLE HUNG WINDOW (LM)	SH900V 6 OF 6	SH900V-FPA-LMI
GLAZING DETAILS		GLAZING DETAILS	

