

# SGD930V, SLIDING PATIO DOOR, LARGE MISSILE IMPACT RESISTANT, BYPASS AND EXTERIOR POCKET, 2, 3 & 4 TRACK CONFIGURATIONS

**GENERAL NOTES:**

- 1) THIS PRODUCT HAS BEEN EVALUATED AND IS IN COMPLIANCE WITH THE FLORIDA BUILDING CODE (FBC) INCLUDING THE "HIGH VELOCITY HURRICANE ZONE" (HVHZ).
- 2) PRODUCT ANCHORS SHALL BE AS LISTED AND SPACED AS SHOWN ON DETAILS. ANCHOR EMBEDMENT TO BASE MATERIAL SHALL BE BEYOND WALL DRESSING OR STUCCO.
- 3) WHEN USED IN AREAS REQUIRING WIND BORNE DEBRIS PROTECTION, THIS PRODUCT COMPLIES WITH FBC SECTIONS 1609.1.2, R301.2.1.2, AND 1626 AND DOES NOT REQUIRE AN IMPACT RESISTANT COVERING. THIS PRODUCTS MEETS MISSILE LEVEL "D" AND INCLUDES WIND ZONE 4 AS DEFINED IN ASTM E1996 AND FBC SECTIONS 1609.1.2.2 AND R301.2.1.2.1 AND ALSO COMPLIES WITH SECTION 1626 (HVHZ).
- 4) FOR 2X STUD FRAMING CONSTRUCTION, ANCHORING OF THESE UNITS SHALL BE THE SAME AS THAT SHOWN FOR 2X BUCK MASONRY CONSTRUCTION. 1X BUCKS ARE OPTIONAL, IF USED, INSTALLATION ANCHORS WILL GO THRU THE 1X INTO THE MASONRY CONSTRUCTION. CAN INSTALL DIRECTLY INTO MASONRY WITH A 1/4" MAX SHIM.
- 5) SITE CONDITIONS THAT DEVIATE FROM THE DETAILS OF THIS DRAWING REQUIRE FURTHER ENGINEERING ANALYSIS BY A LICENSED ENGINEER OR REGISTERED ARCHITECT.

TABLE 1P: DESIGN PRESSURES FOR PVB INTERLAYER

Design Pressure (+/- psf) - PVB INTERLAYER															
Frame Height	DLO Height	DLO Width													
		33.855		39.855		43.855		46.200		47.855		49.855		51.855	
80.000	67.825	60.0	-65.0	55.5	-65.0	53.1	-65.0	51.8	-65.0	51.2	-65.0	50.4	-65.0	49.7	-65.0
84.000	71.825	56.4	-65.0	51.8	-65.0	49.5	-65.0	48.1	-65.0	47.6	-65.0	46.8	-64.3	46.1	-63.3
88.000	75.825	53.0	-65.0	48.6	-65.0	46.3	-63.6	44.9	-61.8	44.4	-61.1	43.6	-60.0		
92.000	79.825	50.0	-65.0	45.7	-62.9	43.5	-59.8	42.2	-58.0	41.6	-57.2				
95.500	83.325	47.7	-65.0	43.5	-59.8	41.3	-56.8	40.0	-55.0						

TABLE 1S: DESIGN PRESSURES FOR SG INTERLAYER

Design Pressure (+/- psf) - SG INTERLAYER															
Frame Height	DLO Height	DLO Width													
		33.855		39.855		43.855		46.200		47.855		49.855		51.855	
80.000	67.825	60.0	-65.0	60.0	-65.0	59.8	-65.0	58.3	-64.7	57.6	-64.1	56.7	-63.1	56.0	-62.2
84.000	71.825	60.0	-65.0	58.3	-64.8	55.7	-61.8	54.1	-60.2	53.5	-59.5	52.6	-58.5	51.8	-57.6
88.000	75.825	59.7	-65.0	54.6	-60.7	52.1	-57.9	50.6	-56.2	50.0	-55.5	49.1	-54.5		
92.000	79.825	56.3	-62.5	51.4	-57.1	48.9	-54.3	47.4	-52.7	46.8	-52.0				
95.500	83.325	53.6	-59.6	48.9	-54.3	46.4	-51.6	45.0	-50.0						

IF WATER INFILTRATION RESISTANCE IS NOT REQUIRED OR OVERHANG IS PER FIG 1, A SILL RISER IS NOT REQUIRED.

TABLE 3: INSTALLATION ANCHORS

Anchor Type	Substrate	Min. Embedment	Min. Edge Distance	Min. On Center
1/4" Elco Ultracon	Concrete/CMU	1-3/8"	1-1/8"	4"
#10 SMS	Wood	1-3/8"	1-1/8"	1"
#10 SMS	Steel Stud	.056"	5/8"	1"

**ANCHOR NOTES:**

- 1) CONCRETE ANCHOR LOCATIONS AT THE CORNERS MAY BE ADJUSTED TO MAINTAIN THE MINIMUM EDGE DISTANCE TO MORTOR JOINTS.
- 2) CONCRETE ANCHOR LOCATIONS NOTED AS "MAX. ON CENTER" MUST BE ADJUSTED TO MAINTAIN THE MINIMUM EDGE DISTANCE TO MORTOR JOINTS, ADDITIONAL CONCRETE ANCHORS MAY BE REQUIRED TO ENSURE THE "MAX. ON CENTER" DIMENSION IS NOT EXCEEDED.
- 3) SHEET METAL SCREWS MUST PENETRATE A MIN. OF 3 THREADS THRU THE STEEL STUD.

TABLE 2: SILL RISER POS. (+) DP

Water-Limited (+) Design Pressure		
Sill Riser	Sill Height	Max. (+) DP Allowed
None	1.688"	See Note B
Standard	2.81"	+50.0 psf
High Dam	4"	+60.0 psf

**NOTES:**

A) IF WATER INFILTRATION RESISTANCE IS REQUIRED, THE LESSER VALUES OF EITHER TABLES 1P OR TABLE 1S AND TABLE 2 DETERMINES THE WATER LIMITED (+) DP.

B) IF WATER INFILTRATION RESISTANCE IS NOT REQUIRED OR OVERHANG IS PER FIG 1, A SILL RISER IS NOT REQUIRED. IF SO, +DP'S SHOWN IN TABLE 1 MAY BE USED.

FIG 1 OH LENGTH

OH HEIGHT  
DOOR ASSEMBLIES INSTALLED WHERE THE OVERHANG (OH) LENGTH IS EQUAL TO OR GREATER THAN THE OVERHANG HEIGHT IS EXEMPTED FROM WATER INFILTRATION RESISTANCE.

GENERAL NOTES.....	1
DP & ANCHOR TABLES.....	1
CONFIGURATIONS.....	2-3
SIZING TABLE.....	3
SECTION VIEWS.....	4-5
GLAZING DETAILS.....	5
FRAME ANCHORAGE.....	7-9
EXTRUSIONS.....	10
BILL OF MATERIALS.....	10

PREPARED BY A. LYNN MILLER 1070 TECHNOLOGY DRIVE N. VENICE, FL 34275 (941) 480-1600	REGISTRATION #29296 COPYRIGHT © 2023 PGT, INC., LIMITED LICENSE TO MAKE COPIES FOR PERMITTING.	Date: 04/18/23 Drawn By: JENS ROSOWSKI	VINYL SLIDING GLASS DOOR (LM) ANCHORAGE GENERAL NOTES, DP, ANCHORAGE 1 OF 10 SGD930V-FPA-LM
--	--	---	---

ANTHONY LYNN MILLER  
 LICENSE  
 No. 58705  
 08/18/23  
 STATE OF FLORIDA  
 PROFESSIONAL ENGINEER  
 A. LYNN MILLER, P.E.  
 P.E.# 58705

Rev. # 08/17/23 Date MINOR EDITORIAL UPDATES

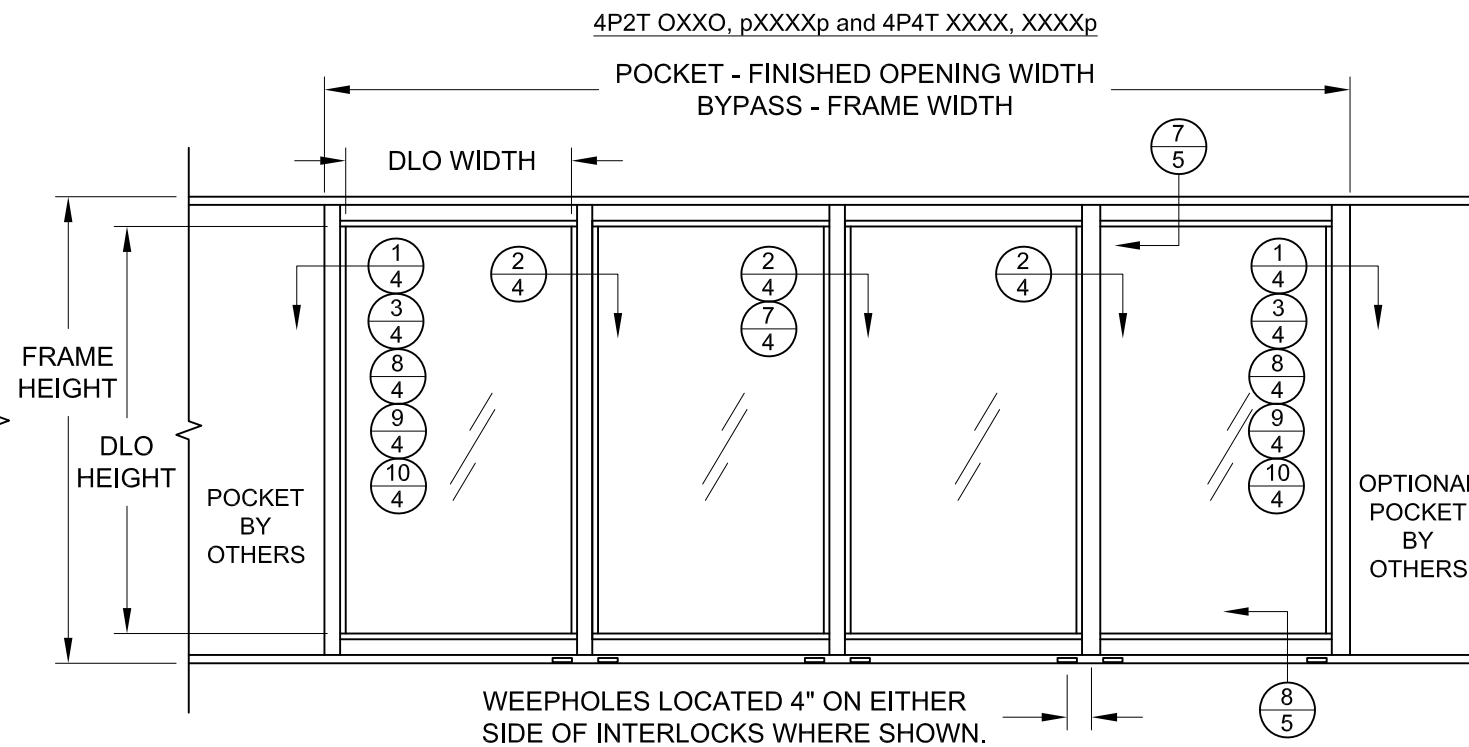
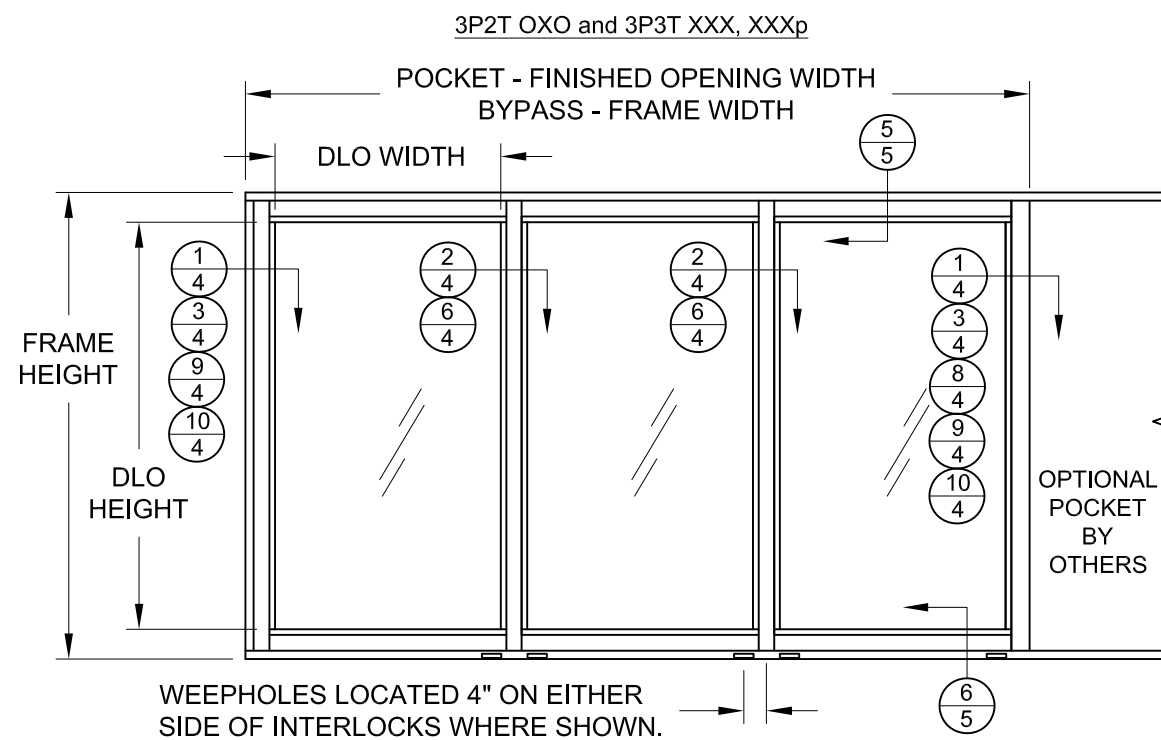
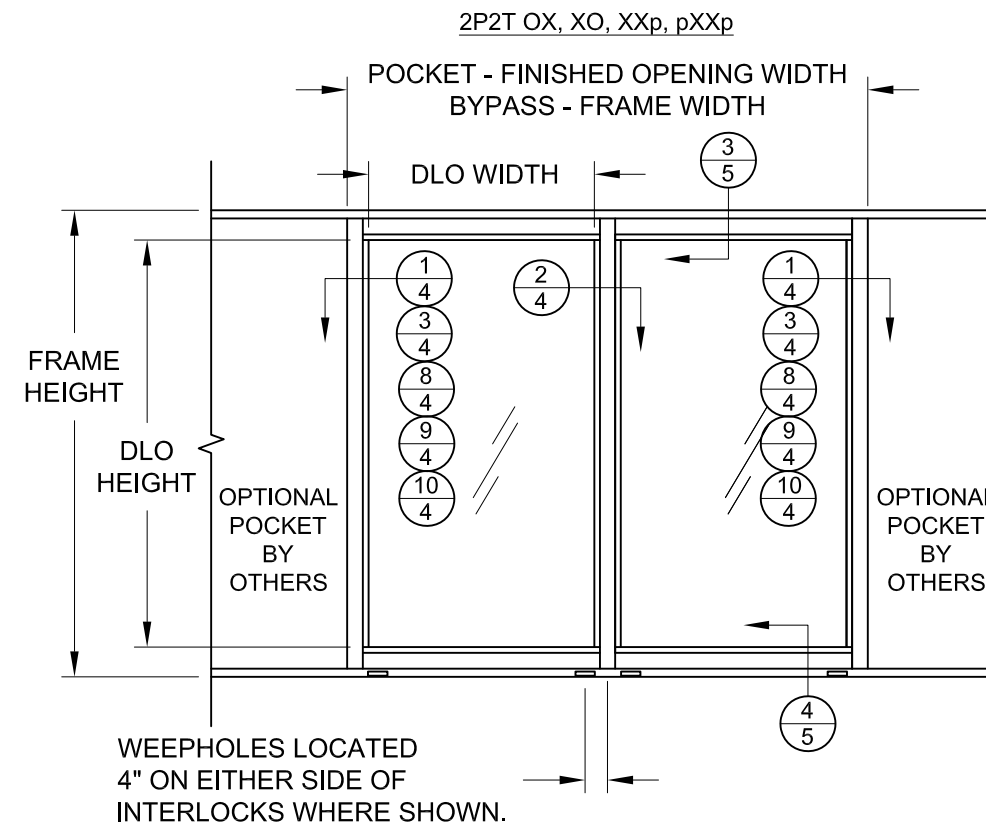
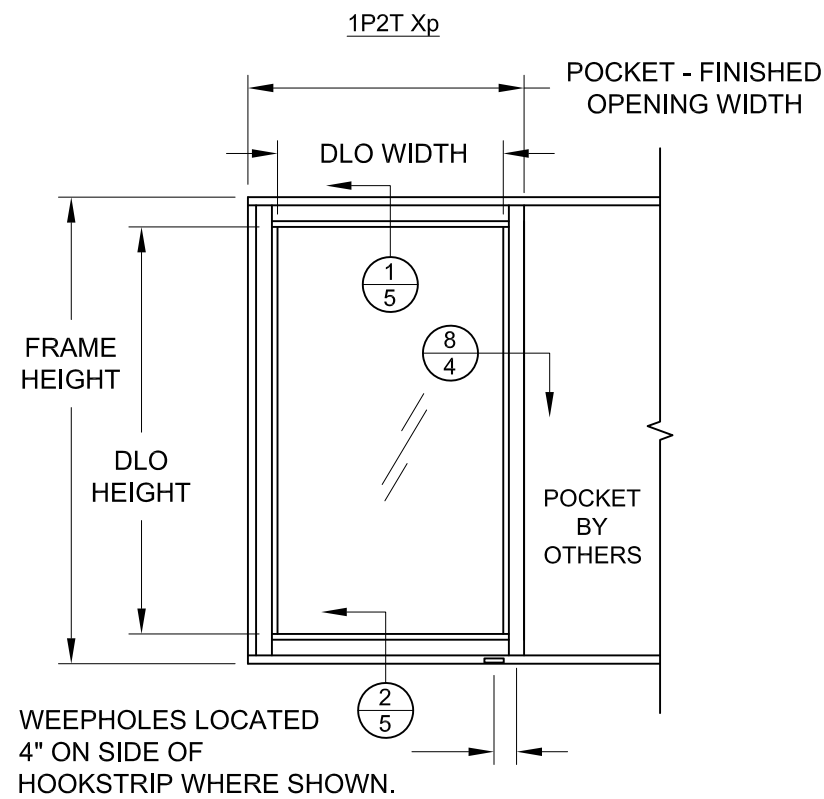

**CONFIGURATION NOTES:**

- 1) SINGLE EXTERIOR POCKET CAN BE EITHER LEFT OR RIGHT.
- 2) POCKET WALL OR CAVITY IS NOT PART OF THIS APPROVAL AND IS TO BE DESIGNED BY OTHERS AND REVIEWED BY THE AUTHORITY HAVING JURISDICTION.

PREPARED BY A. LYNN MILLER 1070 TECHNOLOGY DRIVE N. VENICE, FL 34275 (941) 480-1600		REGISTRATION #29296 COPYRIGHT © 2023 PGT, INC., LIMITED LICENSE TO MAKE COPIES FOR PERMITTING.	04/18/23 Date	JENS ROSOWSKI Drawn By	SGD930V-FPA-LM No.
<b>Impact Resistant Windows &amp; Doors</b> CGI WINDOWS AND DOORS 3780 W. 104TH STREET HIALEAH, FL 33018		VINYL SLIDING GLASS DOOR (LM)			
2 OF 10 Sheet		CONFIGURATIONS AND SIZING		2 OF 10 No.	
SGD930V Series		2 OF 10 Sheet		JENS ROSOWSKI Drawn By	

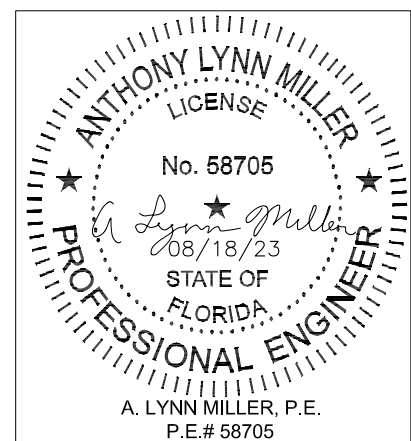

Rev.#	08/17/23
Date	08/17/23
Rev.	MINOR EDITORIAL UPDATES

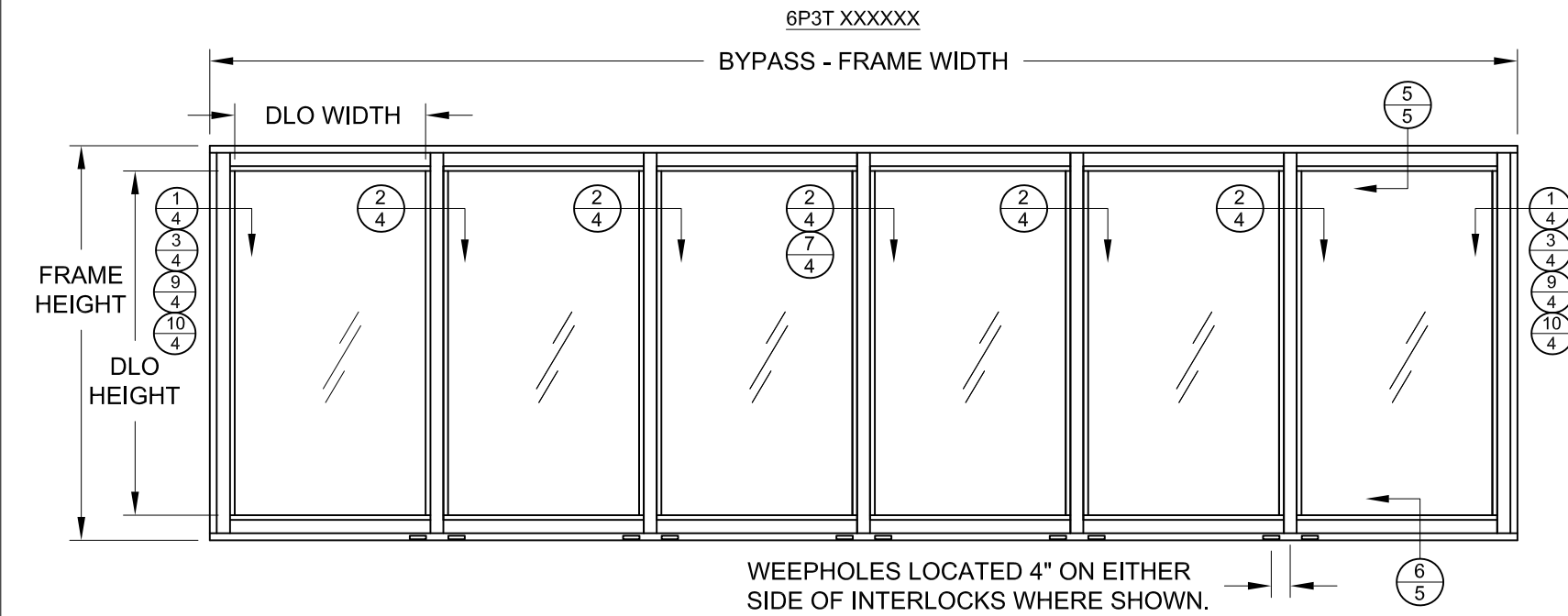
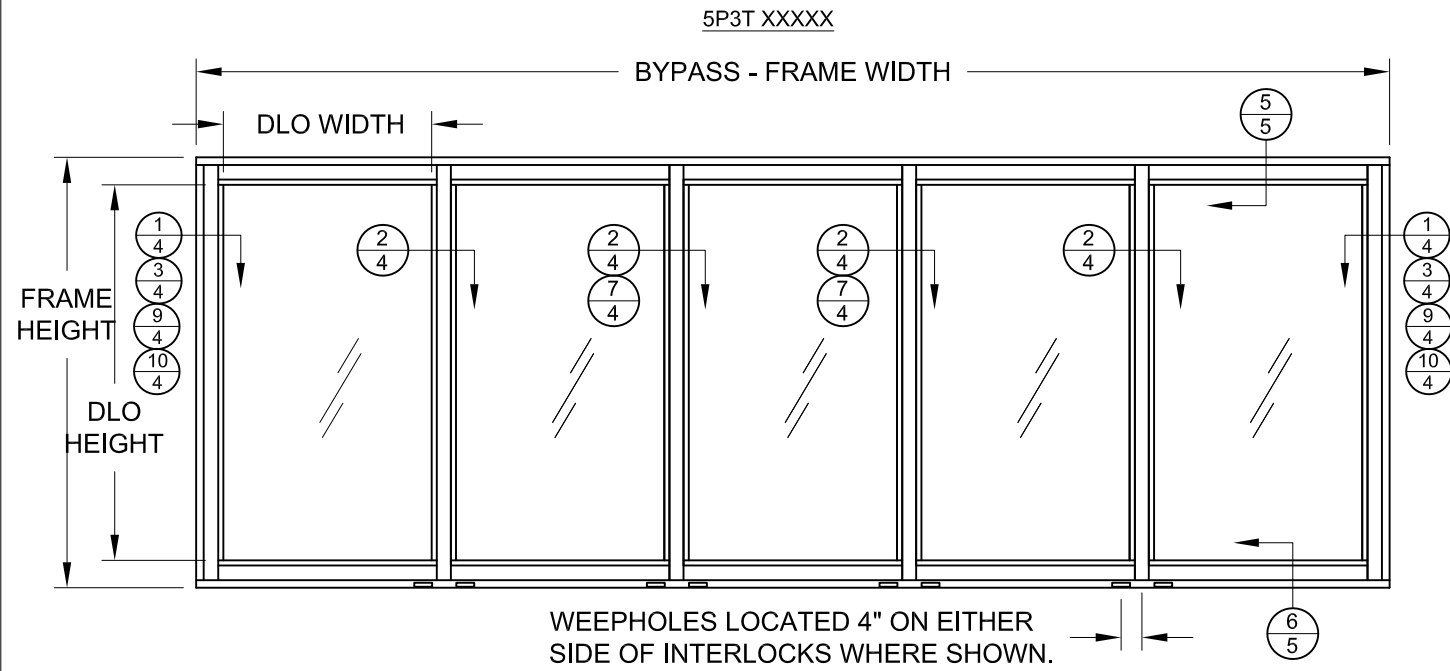

TABLE 4: PANEL DLO, FRAME/FINISHED OPENING WIDTHS

Configuration	Finished Frame Width (in.)						
	DLO Width per Panel (in.)						
	33.855	39.855	43.855	46.200	47.855	49.855	51.855
1P2T Xp	39.030	45.030	49.030	51.375	53.030	55.030	57.030
2P2T XO, OX	84.00	96.00	104.00	108.69	112.00	116.00	120.00
2P2T XXp	78.37	90.37	98.37	103.06	106.37	110.37	114.37
2P2T pXXp	78.37	90.37	98.37	103.06	106.37	110.37	114.37
3P2T OXO	128.09	146.09	158.09	165.13	170.09	176.09	182.09
3P3T XXX	122.78	140.78	152.78	159.81	164.78	170.78	176.78
3P3T XXXp	117.15	135.15	147.15	154.19	159.15	165.15	171.15
4P2T OXXO	167.12	191.12	207.12	216.50	223.12	231.12	239.12
4P2T pXXXXp	155.93	179.93	195.93	205.31	211.93	219.93	227.93
4P4T XXXX	161.56	185.56	201.56	210.94	217.56	225.56	233.56
4P4T XXXXp	155.93	179.93	195.93	205.31	211.93	219.93	227.93
5P3T XXXXX	206.03	236.03	256.03	267.75	276.03	286.03	296.03
6P3T XXXXXX	244.81	280.81	304.81	318.88	328.81	340.81	352.81

CONFIGURATION NOTES:

- 1) SINGLE EXTERIOR POCKET CAN BE EITHER LEFT OR RIGHT.
- 2) POCKET WALL OR CAVITY IS NOT PART OF THIS APPROVAL AND IS TO BE DESIGNED BY OTHERS AND REVIEWED BY THE AUTHORITY HAVING JURISDICTION.

Rev. # 08/17/23  
Date 08/17/23  
MINOR EDITORIAL UPDATES  
Rev. A

PREPARED BY A. LYNN MILLER  
1070 TECHNOLOGY DRIVE  
N. VENICE, FL 34275  
(941) 480-1600

REGISTRATION #29296  
COPYRIGHT © 2023 PGT, INC., LIMITED LICENSE  
TO MAKE COPIES FOR PERMITTING.

CGI WINDOWS AND DOORS  
3780 W. 104TH STREET  
HIALEAH, FL 33018

VINYL SLIDING GLASS DOOR (LM)

CONFIGURATIONS AND SIZING

SGD930V

3 OF 10

SGD930V-FPA-LM

JENS ROSOWSKI

04/18/23

By

Date

Series Desc. Title

ANTHONY LYNN MILLER  
LICENSE  
No. 58705  
A. Lynn Miller  
08/18/23  
STATE OF  
FLORIDA  
PROFESSIONAL ENGINEER  
A. LYNN MILLER, P.E.  
P.E.# 58705

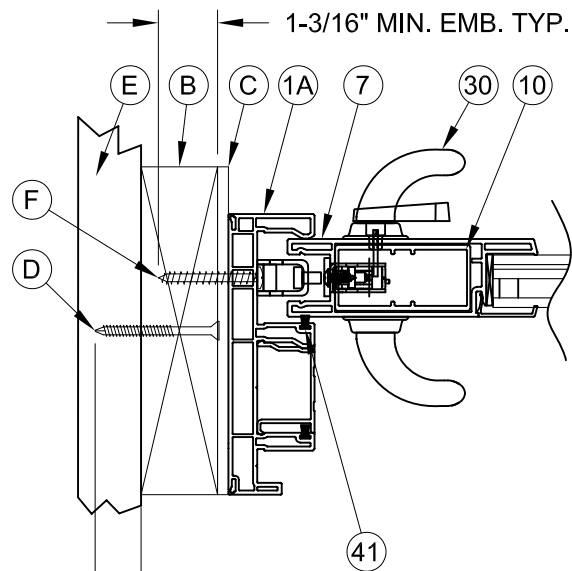

1 HORIZONTAL CROSS SECTION  
3 2X BUCK CONSTRUCTION

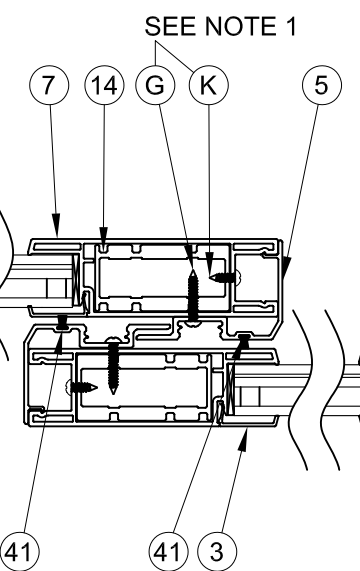

2 HORIZONTAL CROSS SECTION  
3 INTERLOCK

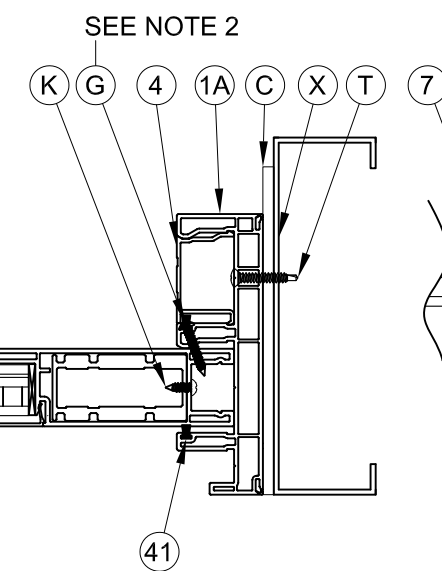

3 HORIZONTAL CROSS SECTION  
3 STEEL STUD CONSTRUCTION  
SEE NOTE 5

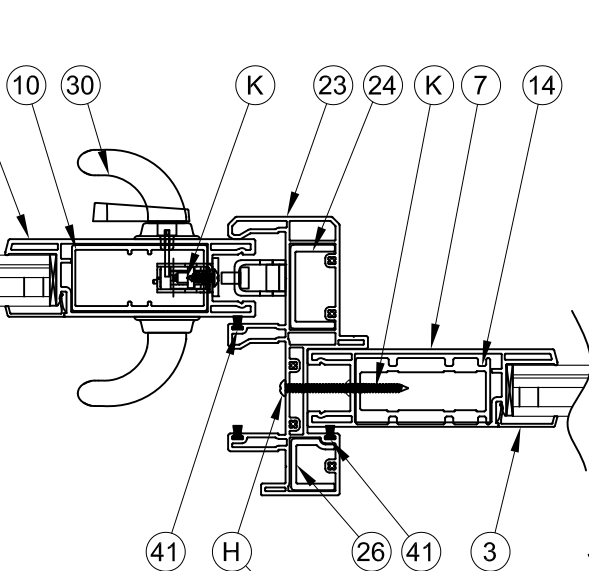

6 HORIZONTAL CROSS SECTION  
3 MULLION (OFFSET BUTTSTILE)

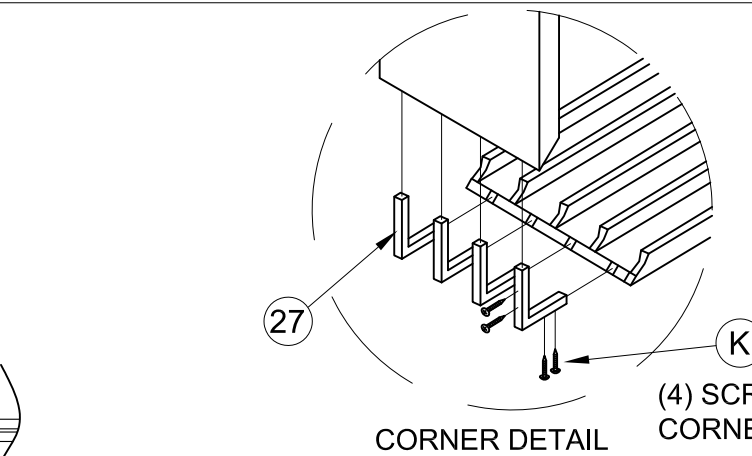

CORNER DETAIL  
(4) SCREWS PER CORNER KEY

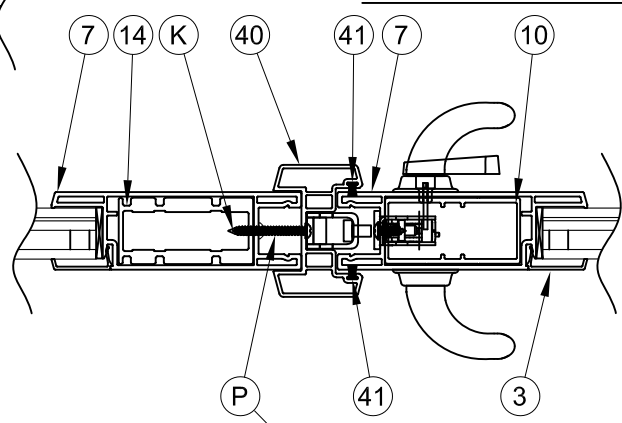

7 HORIZONTAL CROSS SECTION  
3 ASTRAGAL

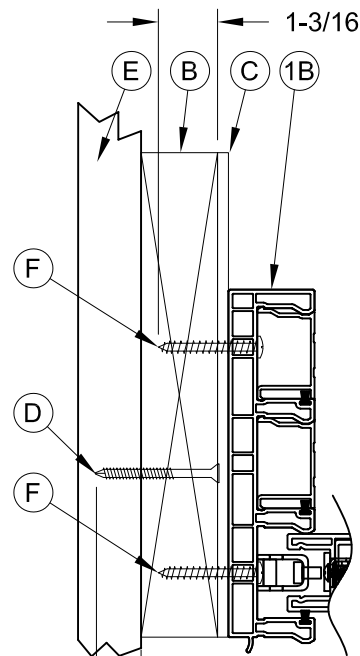

4 HORIZONTAL CROSS SECTION  
3 2X BUCK CONSTRUCTION

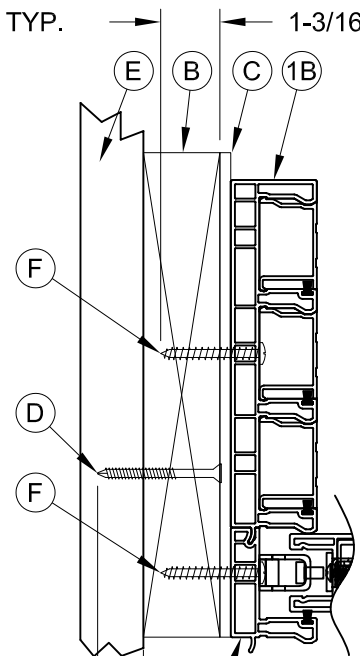

5 HORIZONTAL CROSS SECTION  
3 2X BUCK CONSTRUCTION

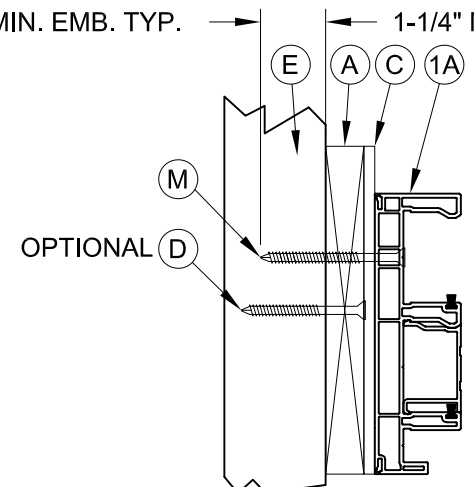

9 HORIZONTAL CROSS SECTION  
3 1X BUCK CONSTRUCTION  
SEE NOTE 4

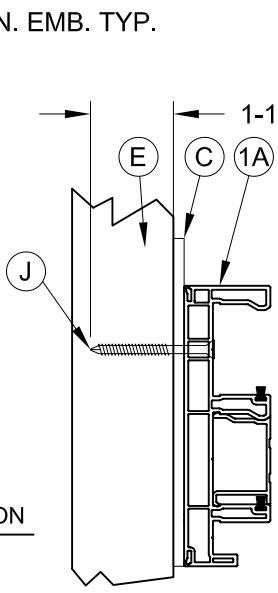

10 HORIZONTAL CROSS SECTION  
3 MASONRY CONSTRUCTION  
SEE NOTE 5

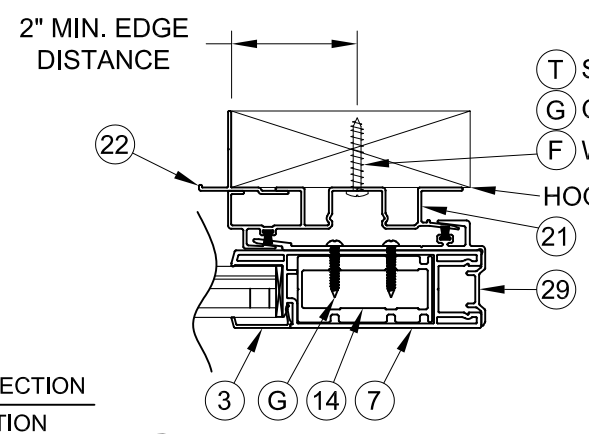

8 HORIZONTAL CROSS SECTION  
3 HOOKSTRIP

T STEEL STUD  
G CONCRETE  
F WOOD  
HOOKSTRIP SUBSTRATE

- NOTES:**
- 1) INTERLOCK REINFORCEMENT SCREWS, G & K, ARE LOCATED 3" FROM EACH END THEN 14.5" ON CENTER.
  - 2) FIXED PANEL IN JAMB SCREWS, G, ARE LOCATED 8" FROM EACH END AND THEN 4 MORE EQUALLY SPACED (6 TOTAL)
  - 3) FIXED PANEL IN MULLION SCREWS, H, AND FIXED PANEL IN ASTRAGAL SCREWS, P, ARE LOCATED 6" FROM EACH END AND THEN 12" ON CENTER.
  - 4) FOR INSTALLATION INTO 1X BUCK CONSTRUCTION, BUCK TO CONCRETE ANCHORS (IF USED) MUST BE AT LEAST 4" FROM PRODUCT INSTALLATION ANCHORS THRU 1X BUCK INTO MASONRY AND FOLLOW MASONRY ANCHOR REQUIREMENTS FROM TABLE 3. APPLIES TO ALL FRAMES.
  - 5) STEEL STUD AND DIRECT TO MASONRY APPLIES TO ALL FRAMES - SEE SECTIONS ABOVE AND SHEETS 6-8 FOR ANCHORAGE FOR EACH FRAME TYPE. (2T, 3T, 4T)

PREPARED BY A. LYNN MILLER 1070 TECHNOLOGY DRIVE N. VENICE, FL 34275 (941) 480-1600	REGISTRATION #29296 COPYRIGHT © 2023 PGT, INC., LIMITED LICENSE TO MAKE COPIES FOR PERMITTING.	Date 04/18/23	Drawn By JENS ROSOWSKI
	CGI WINDOWS AND DOORS 3780 W. 104TH STREET HIALEAH, FL 33018	VINYL SLIDING GLASS DOOR (LM) HORIZONTAL SECTIONS, CORNER KEY DETAIL	No. 4 OF 10

Impact Resistant Windows & Doors  
 ANTHONY LYNN MILLER  
 LICENSE  
 No. 58705  
 State of Florida  
 PROFESSIONAL ENGINEER  
 A. LYNN MILLER, P.E.  
 P.E.# 58705

Rev. # 08/17/23  
Date  
MINOR EDITORIAL UPDATES  
Rev.

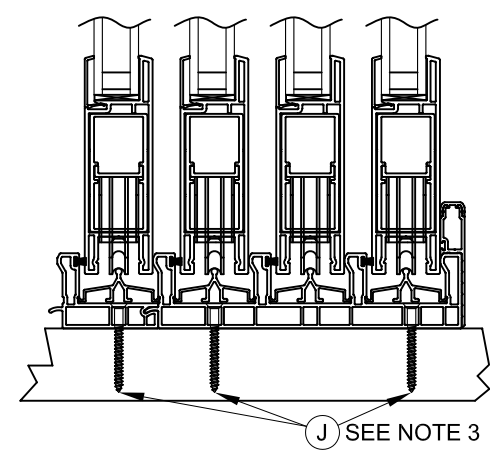
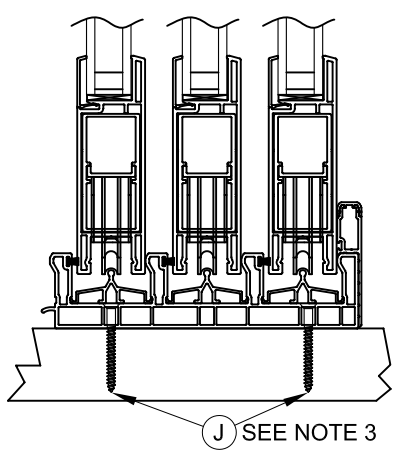
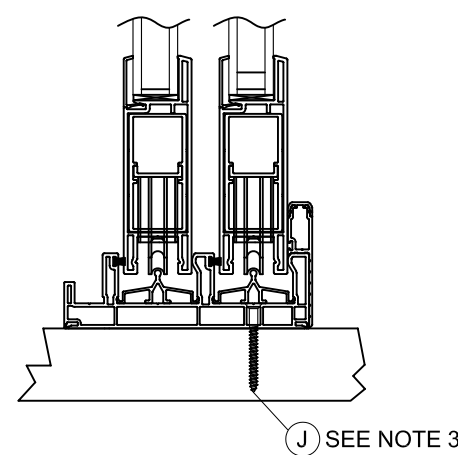
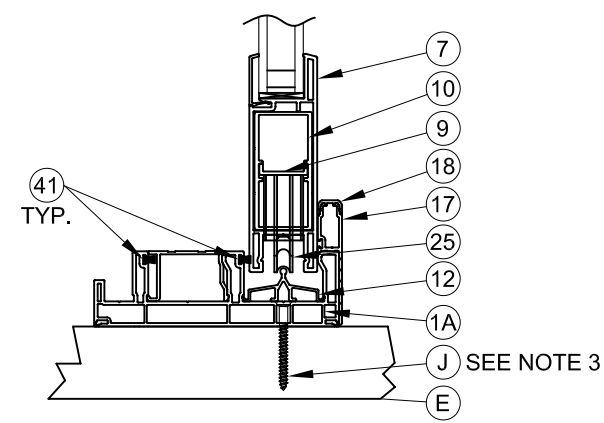
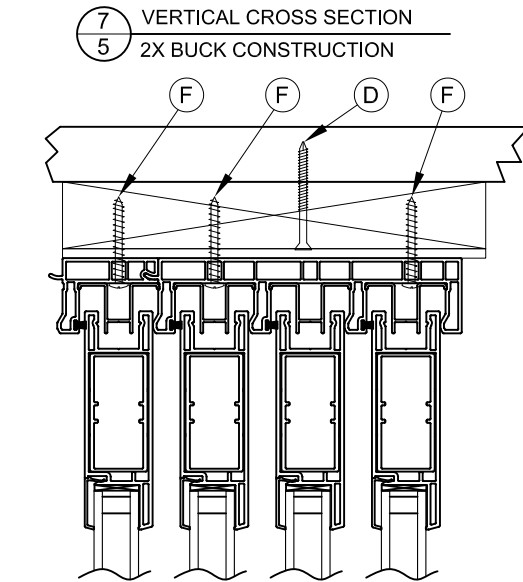
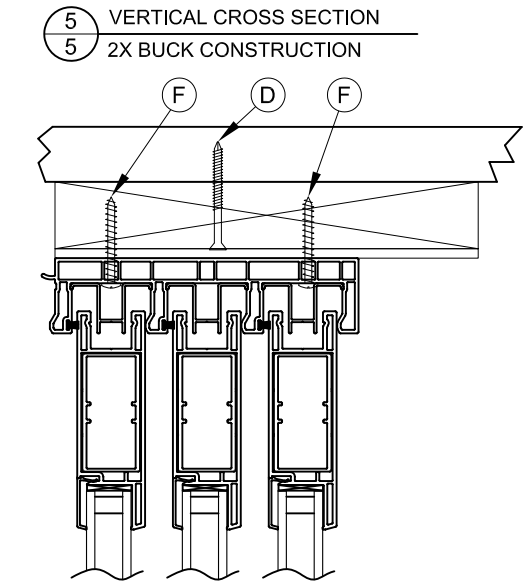
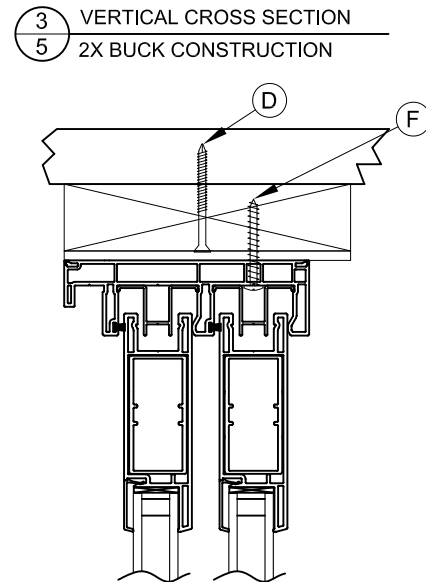
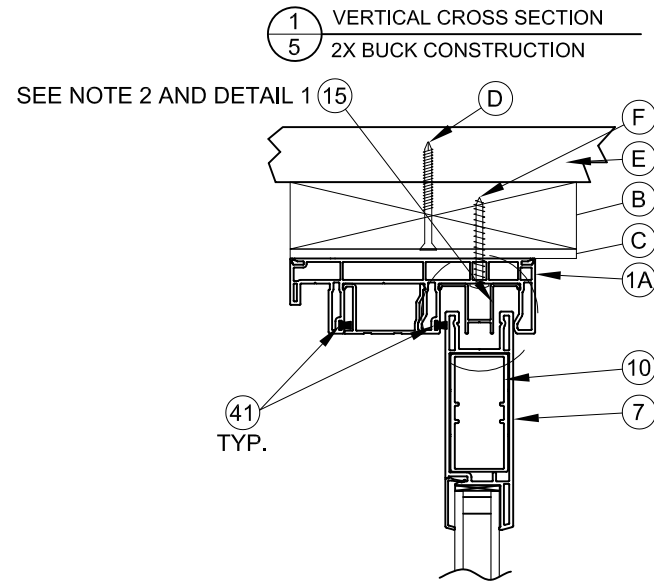
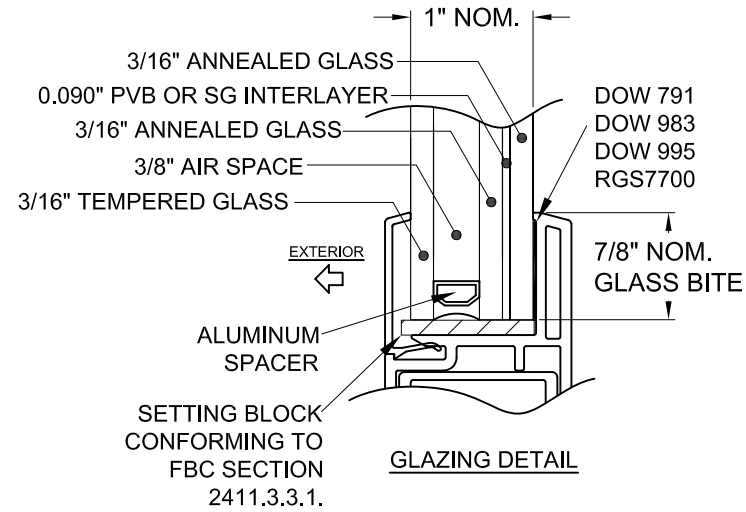
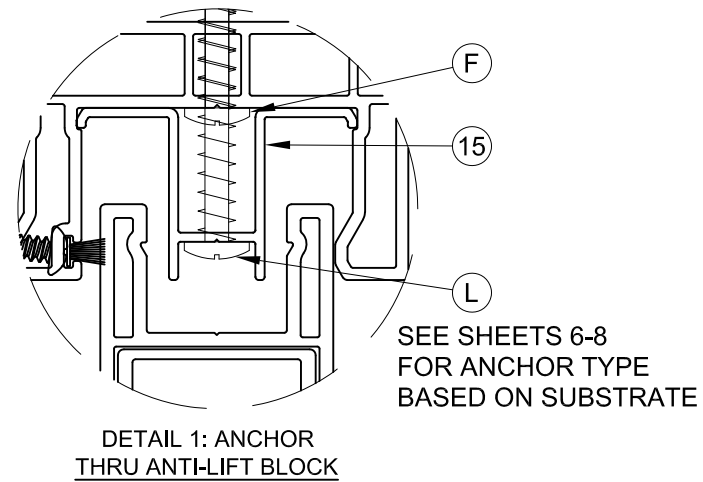

- NOTES:**
- 1) FIXED PANEL SCREW INTO HEAD AND SILL, G, LOCATED 3" AND 6" FROM JAMB AND THEN 6", 9" AND 12" FROM THE INTERLOCK.
  - 2) ANCHOR THRU ANTI-LIFT BLOCK (ITEM #15) NOT SHOWN FOR CLARITY. REFER TO SHEETS 6-8 FOR ANCHOR TYPE.
  - 3) FLAT HEAD ANCHORS MUST BE USED IN SILL, ALL OTHERS INTERFERE WITH ROLLER TRACK.
  - 4) FOR INSTALLATION INTO 1X BUCK CONSTRUCTION, BUCK TO CONCRETE ANCHORS (IF USED) MUST BE AT LEAST 4" FROM PRODUCT INSTALLATION ANCHORS THRU 1X BUCK INTO MASONRY AND FOLLOW MASONRY ANCHOR REQUIREMENTS FROM TABLE 3. APPLIES TO ALL FRAMES.
  - 5) DIRECT TO MASONRY APPLIES TO ALL FRAMES.

PREPARED BY A. LYNN MILLER 1070 TECHNOLOGY DRIVE N. VENICE, FL 34275 (941) 480-1600	REGISTRATION #29296 COPYRIGHT © 2023 PGT, INC., LIMITED LICENSE TO MAKE COPIES FOR PERMITTING.	Date 04/18/23	Drawn By JENS ROSOWSKI	No. 5 OF 10	DWG SGD930V-FPA-LM
	CGI WINDOWS AND DOORS 3780 W. 104TH STREET HIALEAH, FL 33018	Title VINYL SLIDING GLASS DOOR (LM) Desc. VERTICAL SECTIONS, GLAZING DETAIL	Sheet SGD930V	Series 5 OF 10	No. 5 OF 10

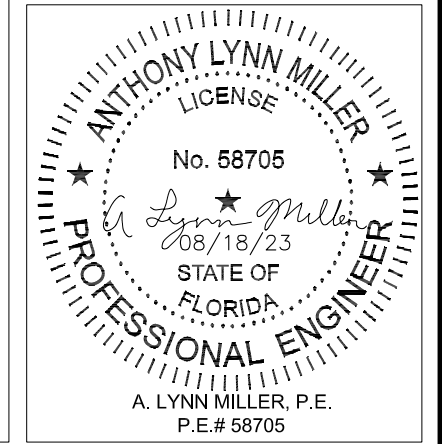

Rev. # 08/17/23  
Date  
MINOR EDITORIAL UPDATES  
Rev.

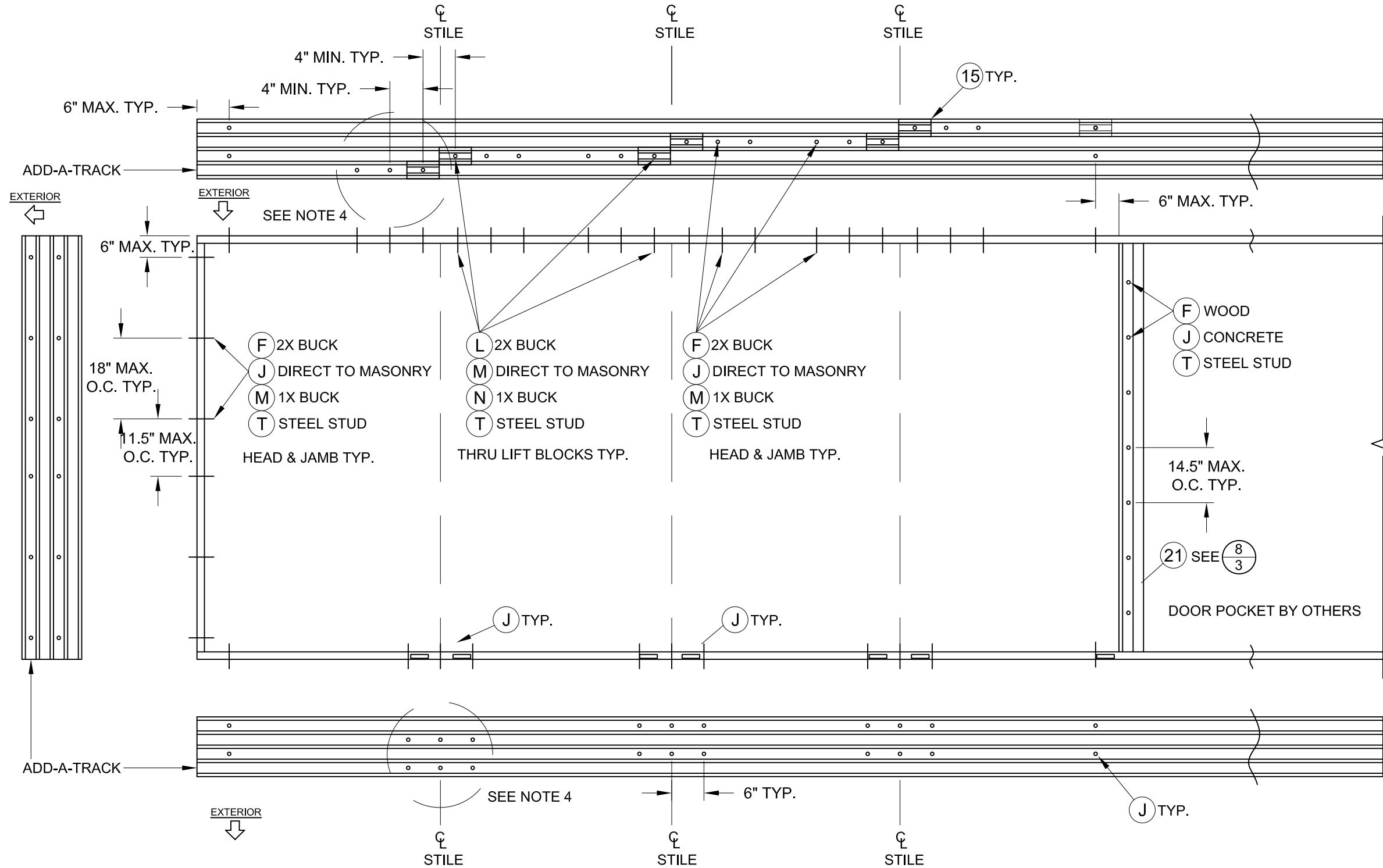

FRAME ANCHORAGE DETAIL  
4T SLIDING GLASS POCKET DOOR

- NOTES:
- 1) ANTI-LIFT BLOCKS (ITEM #15) REQ'D ABOVE ALL ACTIVE PANELS (X).
  - 2) STAGGER ANCHORS ABOUT INTERLOCK CENTERLINES - MIN. 4" O.C., ANCHOR THRU ANTI-LOCK BLOCKS AT HEAD.
  - 3) FOR BYPASS ANCHORAGE, DISMISS THE CLUSTERS NEAR THE POCKET (SHOWN ON RIGHT) AND REPLACE WITH END CLUSTERS (SHOWN ON LEFT)
  - 4) CLUSTER ANCHORS MUST GO THRU THE ADD-A-TRACK WHEN THERE IS AN OPERABLE PANEL PRESENT IN THE ADD-A-TRACK.

PREPARED BY A. LYNN MILLER 1070 TECHNOLOGY DRIVE N. VENICE, FL 34275 (941) 480-1600		REGISTRATION #29296 COPYRIGHT © 2023 PGT, INC., LIMITED LICENSE TO MAKE COPIES FOR PERMITTING.	Date: 04/18/23 Drawn By: JENS ROSOWSKI	No. DWG: 6 OF 10 Series: SGD930V-FPA-LM
<b>Impact Resistant Windows &amp; Doors</b> CGI WINDOWS AND DOORS 3780 W. 104TH STREET HIALEAH, FL 33018		VINYL SLIDING GLASS DOOR (LM) 4T FRAME ANCHORING		

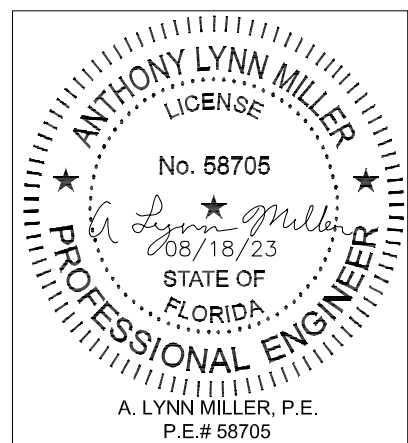

Rev. #	08/17/23
Date	08/17/23
Rev.	MINOR EDITORIAL UPDATES
	A

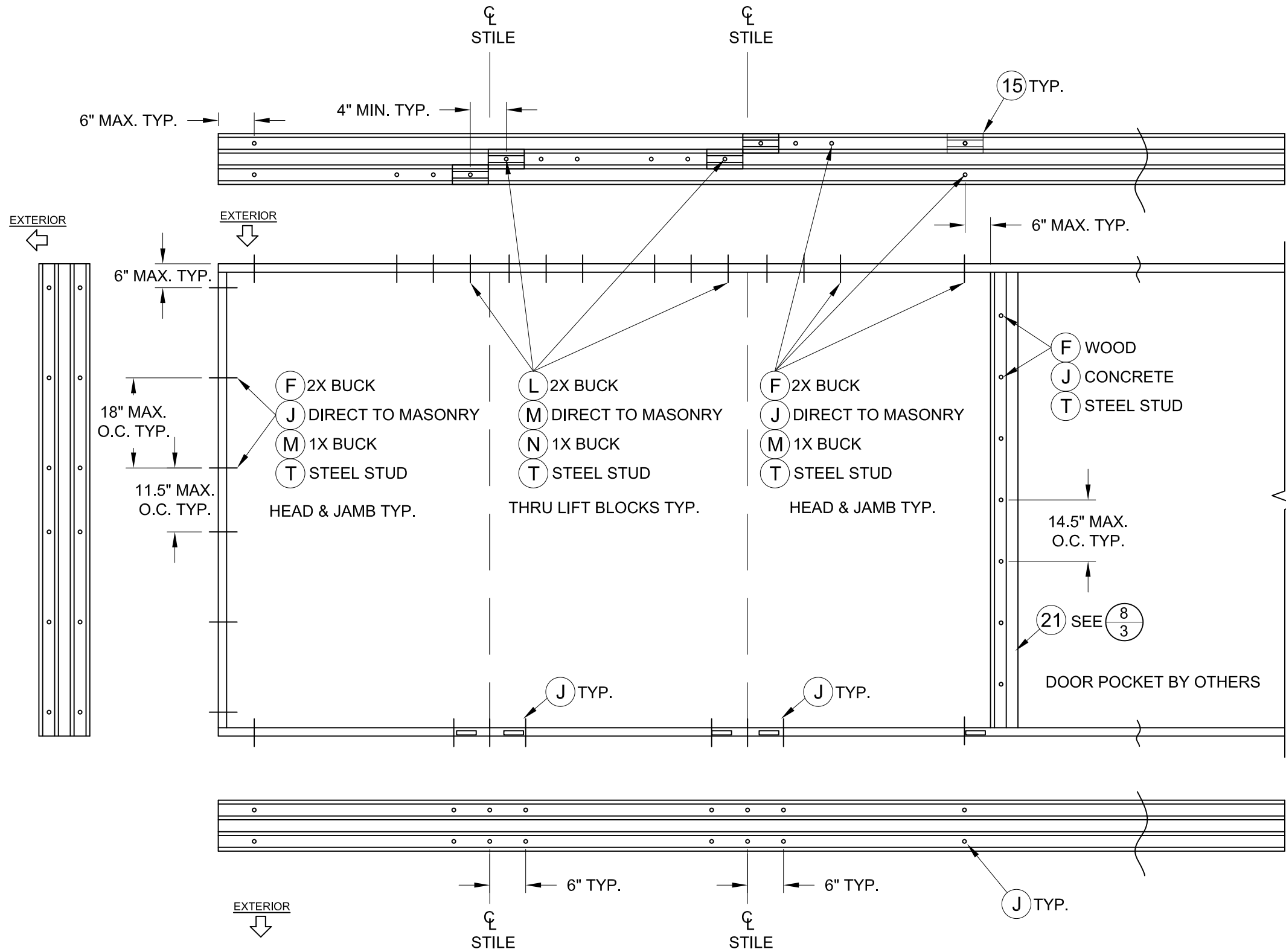

FRAME ANCHORAGE DETAIL  
3T SLIDING GLASS POCKET DOOR

- NOTES:
- 1) ANTI-LIFT BLOCKS (ITEM #15) REQ'D ABOVE ALL ACTIVE PANELS (X).
  - 2) STAGGER ANCHORS ABOUT INTERLOCK CENTERLINES - MIN. 4" O.C., ANCHOR THRU ANTI-LOCK BLOCKS AT HEAD.
  - 3) FOR BYPASS ANCHORAGE, DISMISS THE CLUSTERS NEAR THE POCKET (SHOWN ON RIGHT) AND REPLACE WITH END CLUSTERS (SHOWN ON LEFT)

Rev. #	08/17/23
Date	08/17/23
Rev.	MINOR EDITORIAL UPDATES
	A

PREPARED BY A. LYNN MILLER 1070 TECHNOLOGY DRIVE N. VENICE, FL 34275 (941) 480-1600	REGISTRATION #29296	Date	04/18/23
	COPYRIGHT © 2023 PGT, INC., LIMITED LICENSE TO MAKE COPIES FOR PERMITTING.		
<b>Impact Resistant Windows &amp; Doors</b> CGI WINDOWS AND DOORS 3780 W. 104TH STREET HIALEAH, FL 33018	VINYL SLIDING GLASS DOOR (LM) 3T FRAME ANCHORING	By	JENS ROSOWSKI
		No.	SGD930V-FPA-LM
Sheet	7 OF 10	DWG	
Series	SGD930V		

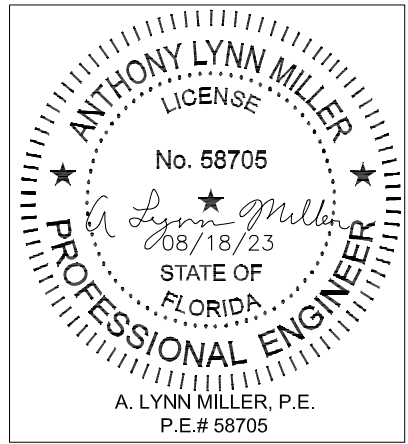

A. LYNN MILLER, P.E.  
P.E.# 58705

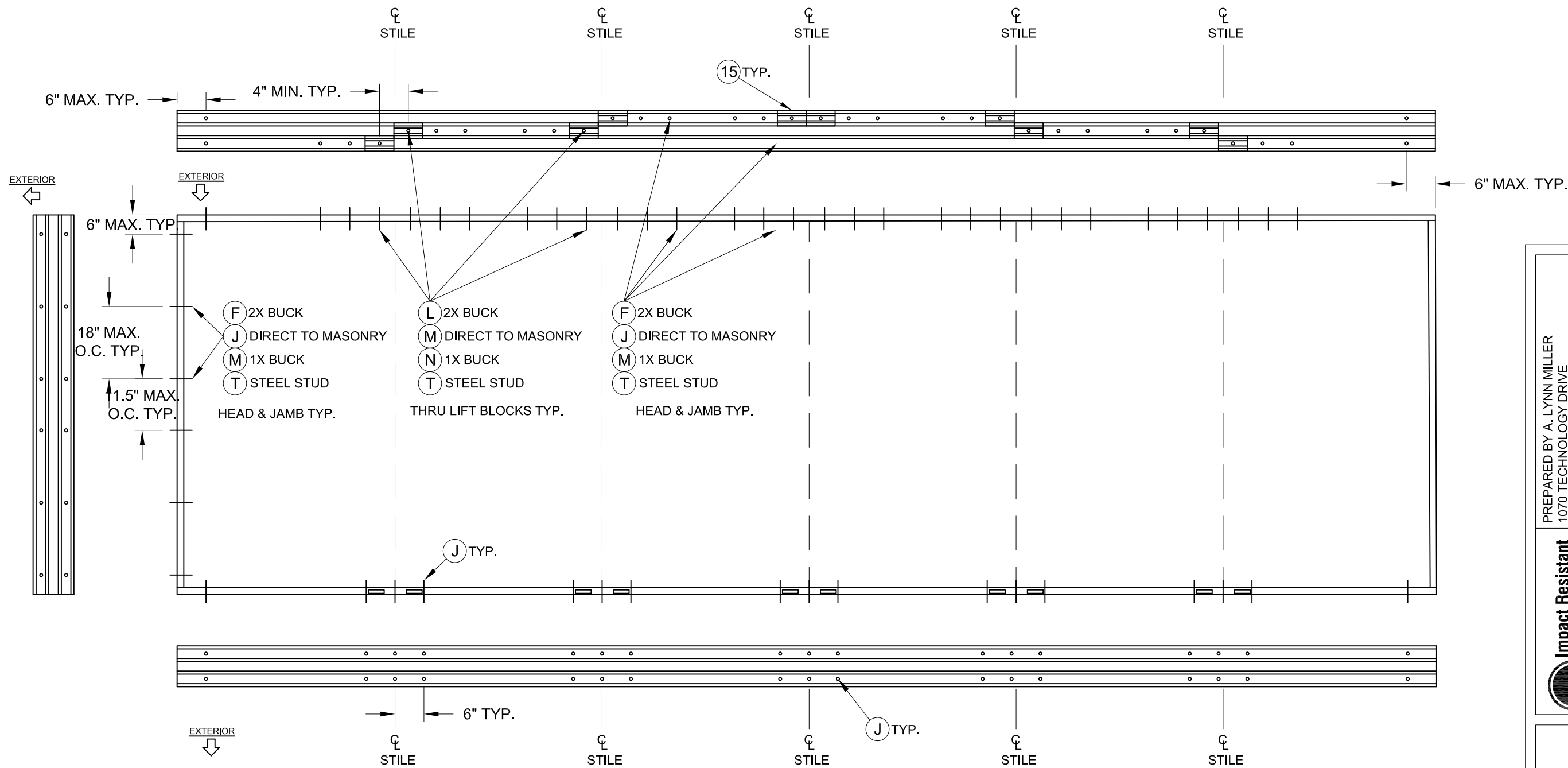

**NOTES:**

- 1) ANTI-LIFT BLOCKS (ITEM #15) REQ'D ABOVE ALL ACTIVE PANELS (X).
- 2) STAGGER ANCHORS ABOUT INTERLOCK CENTERLINES - MIN. 4" O.C., ANCHOR THRU ANTI-LOCK BLOCKS AT HEAD.
- 3) XXXXXX SHOWN, ANCHORAGE SIMILAR FOR XXXXX AND XXX

**FRAME ANCHORAGE DETAIL  
3T SLIDING GLASS DOOR**

<b>Impact Resistant Windows &amp; Doors</b> CGI WINDOWS AND DOORS 3780 W. 104TH STREET HIALEAH, FL 33018	PREPARED BY A. LYNN MILLER 1070 TECHNOLOGY DRIVE N. VENICE, FL 34275 (941) 480-1600	REGISTRATION #29296 COPYRIGHT © 2023 PGT, INC., LIMITED LICENSE TO MAKE COPIES FOR PERMITTING.	04/18/23 Date	JENS ROSOWSKI By	SGD930V-FPA-LM No.
	VINYL SLIDING GLASS DOOR (LM) Title	8 OF 10 Sheet	3T FRAME ANCHORING Desc.	SGD930V Series	

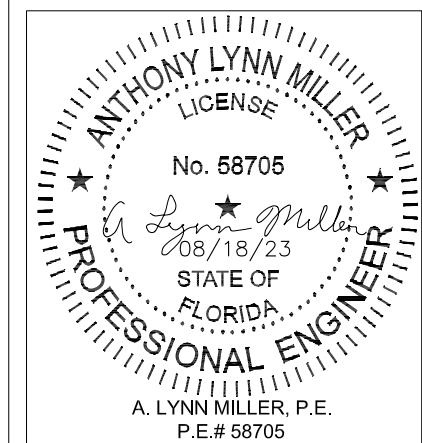

Rev. #	08/17/23	Date
Rev.	MINOR EDITORIAL UPDATES	By
Rev.	A	Date



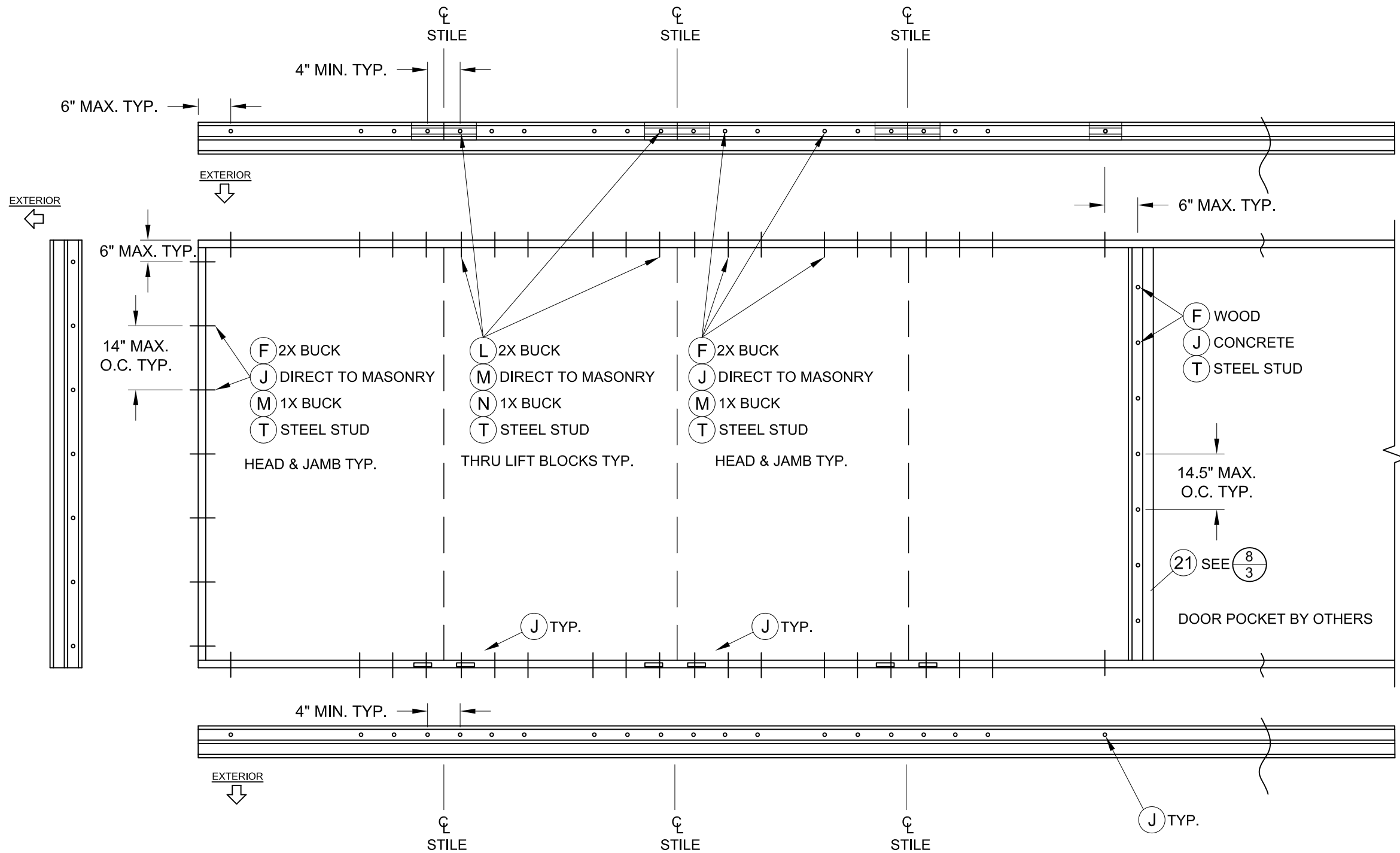

FRAME ANCHORAGE DETAIL  
2T SLIDING GLASS POCKET DOOR

**NOTES:**

- 1) ANTI-LIFT BLOCKS (ITEM #15) REQ'D ABOVE ALL ACTIVE PANELS (X).
- 2) FOR BYPASS ANCHORAGE, DISMISS THE CLUSTERS NEAR THE POCKET (SHOWN ON RIGHT) AND REPLACE WITH END CLUSTERS (SHOWN ON LEFT)

Rev. #	A
Date	08/17/23
Rev.	MINOR EDITORIAL UPDATES

PREPARED BY A. LYNN MILLER 1070 TECHNOLOGY DRIVE N. VENICE, FL 34275 (941) 480-1600	REGISTRATION #29296	Date	04/18/23
	COPYRIGHT © 2023 PGT, INC., LIMITED LICENSE TO MAKE COPIES FOR PERMITTING.		
<b>Impact Resistant Windows &amp; Doors</b> CGI WINDOWS AND DOORS 3780 W. 104TH STREET HIALEAH, FL 33018	VINYL SLIDING GLASS DOOR (LM)	Drawn By	JENS ROSOWSKI
		No. DWG	9 OF 10
Series	SGD930V	Sheet	SGD930V-FPA-LM

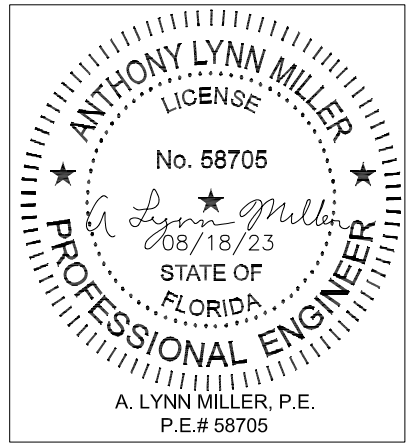

**BILL OF MATERIALS**

ITEM #	DESCRIPTION	MATERIAL
A	1X BUCK (SG>=0.42)	WOOD
B	2X BUCK (SG>=0.42)	WOOD
C	1/4" MAX SHIM SPACE	-
D	1/4" X 2-3/4" ELCO ULTRACON OR ULTRACON+ CONCRETE SCREW	STEEL
E	MASONRY - 3000 PSI MIN CONCRETE CONFORMING TO ACI 301 OR HOLLOW BLOCK CONFORMING TO ASTM C90	CONCRETE
F	#10 X 2" PPH SMS	STEEL
G	#8 X 1" PPH SMS	STEEL
H	#10 X 2-1/2" PPH SMS	STEEL
J	1/4" X 2-1/4" ELCO ULTRACON OR ULTRACON+ CONCRETE SCREW	STEEL
K	#8 X 1/2" PPH SMS	STEEL
L	#10 X 3" PPH SMS	STEEL
M	1/4" X 3-1/4" ELCO ULTRACON OR ULTRACON+ CONCRETE SCREW	STEEL
N	1/4" X 3-3/4" ELCO ULTRACON OR ULTRACON+ CONCRETE SCREW	STEEL
P	#8 X 1-1/2" PPH SMS	STEEL
T	#10-16 PH SELF-DRILLING SMS (3 THREADS MIN. THRU STUD)	STEEL
X	STEEL STUD MIN THICKNESS 0.056" (ASTM A653 GRADE 50, FY=50 KSI MIN., FU=65 KSI MIN.)	STEEL
1A	FRAME - 2T	PVC
1B	FRAME - 3T	PVC
2	ADD-A-TRACK	PVC
3	GLAZING BEAD	PVC
4	FRAME CAP (JAMB COVER)	PVC
5	INTERLOCK	6063-T5
6	SILL CAP (THRESHOLD)	6063-T5
7	PANEL STILE/RAIL	PVC
9	ROLLER SUPPORT	6063-T5
10	REINFORCEMENT (LOCK STILE, TOP/BTM RAIL)	6065-T5
11	FIXED PANEL SUPPORT	6065-T5
12	ROLLER TRACK	6063-T5
14	HD REINFORCEMENT (INTERLOCK)	ALUM
15	ANTI-LIFT OUT BLOCK	6063-T5
17	STANDARD SILL RISER	6063-T5
18	SILL RISER CAP	6063-T5
19	HIGH DAM SILL RISER	6063-T5
21	HOOKSTRIP	6063-T5
22	HOOKSTRIP FLANGE	6063-T5
23	MULLION (OFFSET BUTTSTILE)	PVC
24	REINFORCEMENT - MULLION (LARGE)	6063-T5
25	ROLLER ASSEMBLY	STEEL
26	REINFORCEMENT - MULLION (SMALL)	6063-T5
27	CORNER KEY	PVC
29	DOUBLE INTERLOCK (PANEL TO HOOKSTRIP)	6063-T5
30	LOCK AND HANDLE	-
31	STRIKE PLATE	-
39	SCREW COVER (HOOKSTRIP)	PVC
40	ASTRAGAL	6063-T5
41	WTSP, .187 x .290 Poly Fin	
42	WTSP, 0.8125" x 0.875" x 4" Fuzzy Pad (TOP/BTM RAIL)	

THE APPROVED, RIGID PVC EXTERIOR EXTRUSIONS ARE TO BE PRODUCED BY EXTRUDERS' LICENSEES UNDER "AAMA CERTIFICATION PROGRAMS FOR RIGID PVC EXTRUSIONS".

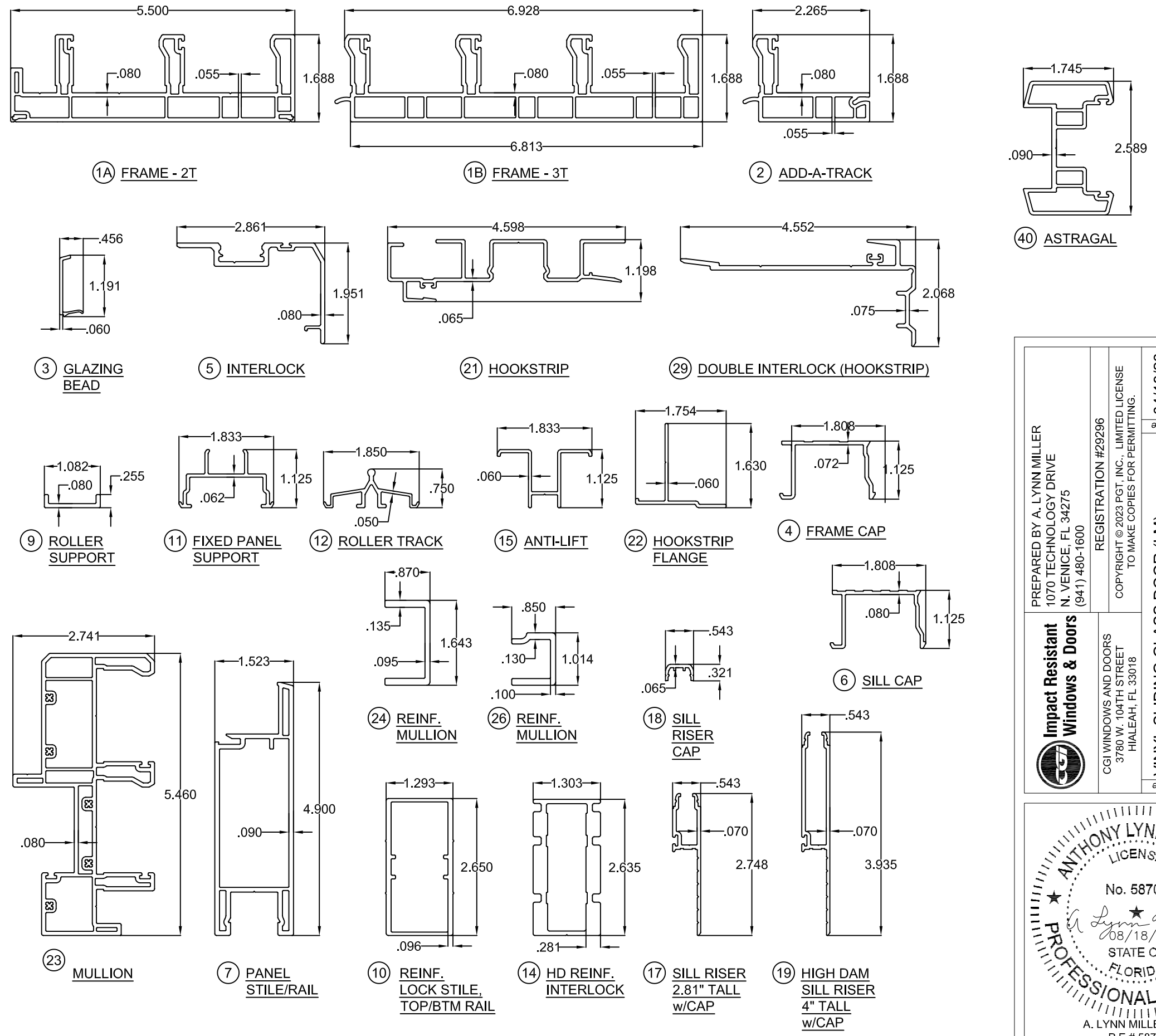

Rev.# 08/17/23  
Date 08/17/23  
MINOR EDITORIAL UPDATES  
Rev.

Prepared by A. LYNN MILLER  
1070 TECHNOLOGY DRIVE  
N. VENICE, FL 34275  
(941) 480-1600

REGISTRATION #29296  
COPYRIGHT © 2023 PGT, INC., LIMITED LICENSE  
TO MAKE COPIES FOR PERMITTING.

CGI WINDOWS AND DOORS  
3780 W. 104TH STREET  
HIALEAH, FL 33018

DATE: 04/18/23  
DRAWN BY: JENS ROSOWSKI  
TITLE: VINYL SLIDING GLASS DOOR (LM)

SGD930V - FPA-LM  
10 OF 10  
SGD930V

Impact Resistant Windows & Doors

ANTHONY LYNN MILLER  
LICENSE  
No. 58705  
08/18/23  
STATE OF FLORIDA  
PROFESSIONAL ENGINEER  
A. LYNN MILLER, P.E.  
P.E.# 58705