

# ELEVATION

FRAME, PANEL AND D.L.O. ABOVE BASED ON ACTUAL TEST  
SPECIMEN SIZE  
(EXTERIOR VIEW)

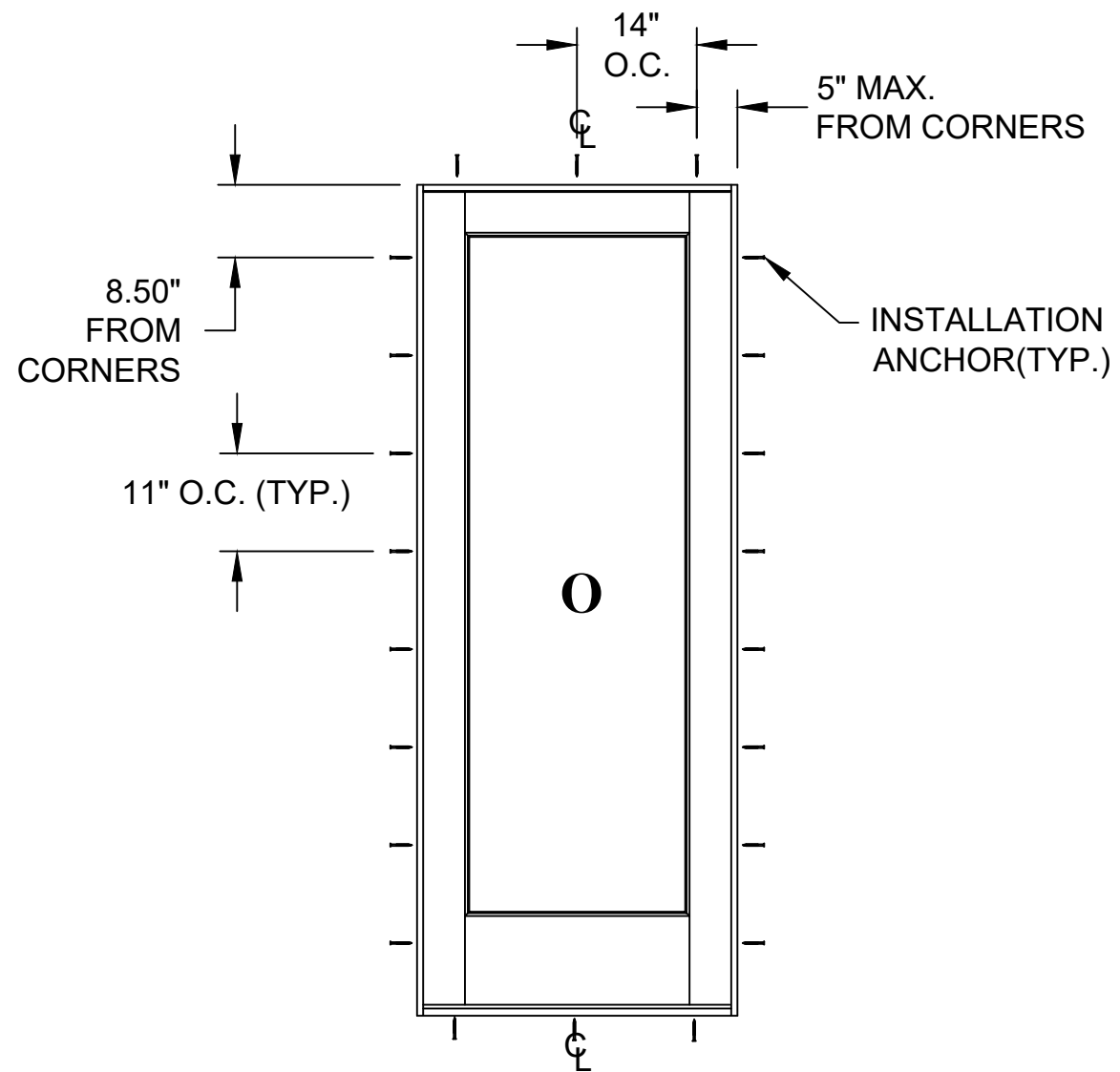

# ANCHOR LAYOUT

(EXTERIOR VIEW)

PROJECT NO. 421-0102

SIMPSON DOOR COMPANY  
400 SIMPSON AVE.  
MCCLEARY, WA 98557

TITLE: WESTAR HIGH IMPACT FIXED SINGLE SIDELITE  
ELEVATION & ANCHOR LAYOUT

DATE:	6/8/21
DRAWN BY:	RJA
SCALE:	N.T.S.
DRAWING NO.:	SIMP0016
REV.:	---
SHEET:	2 OF 4

REV	DESCRIPTION	DATE	BY

Robert J. Amoruso, P.E.  
Florida P.E. No. 49752



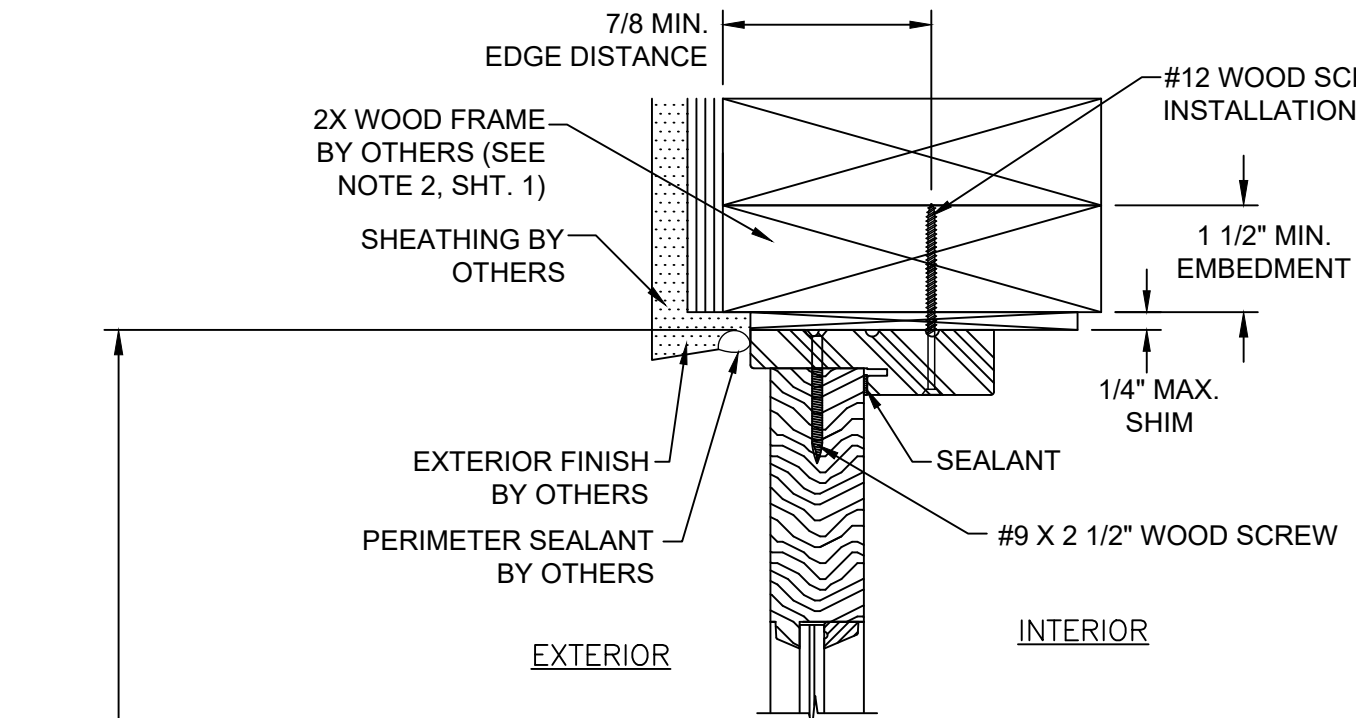

**B** VERTICAL SECTION  
WOOD FRAME SUBSTRATE

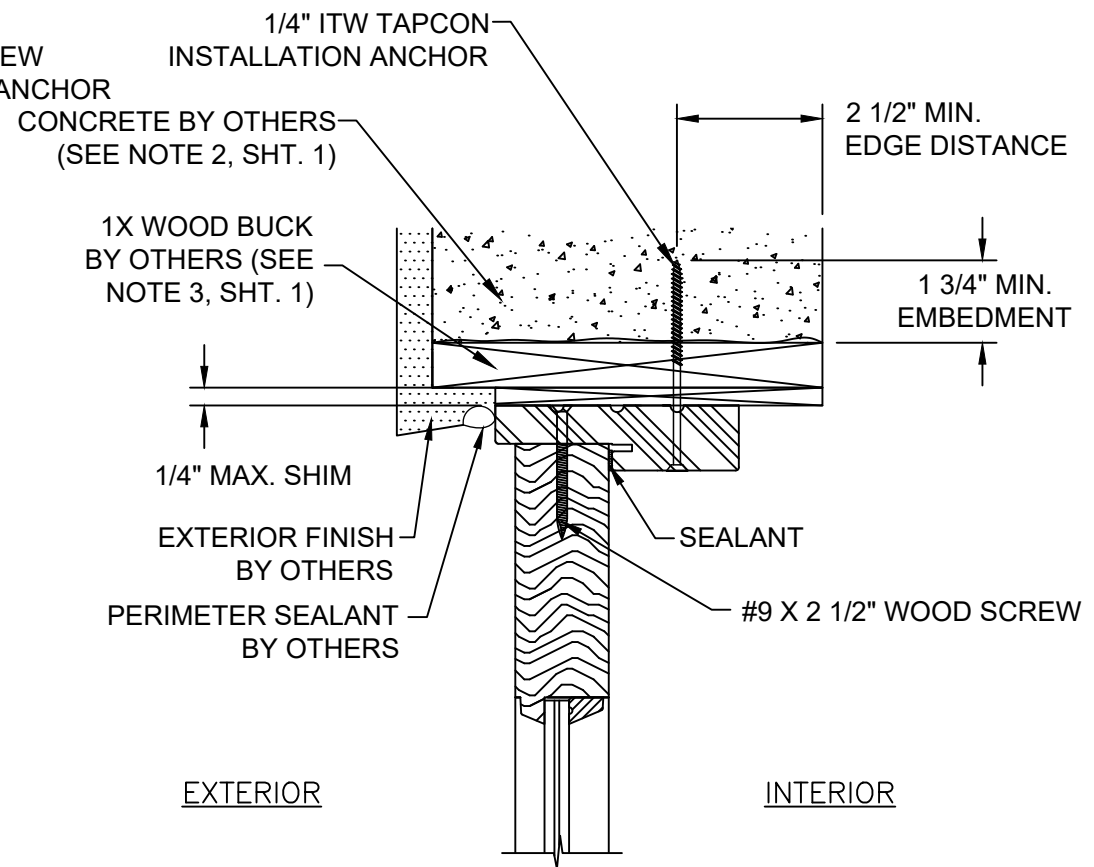

**C** VERTICAL SECTION  
CONCRETE SUBSTRATE

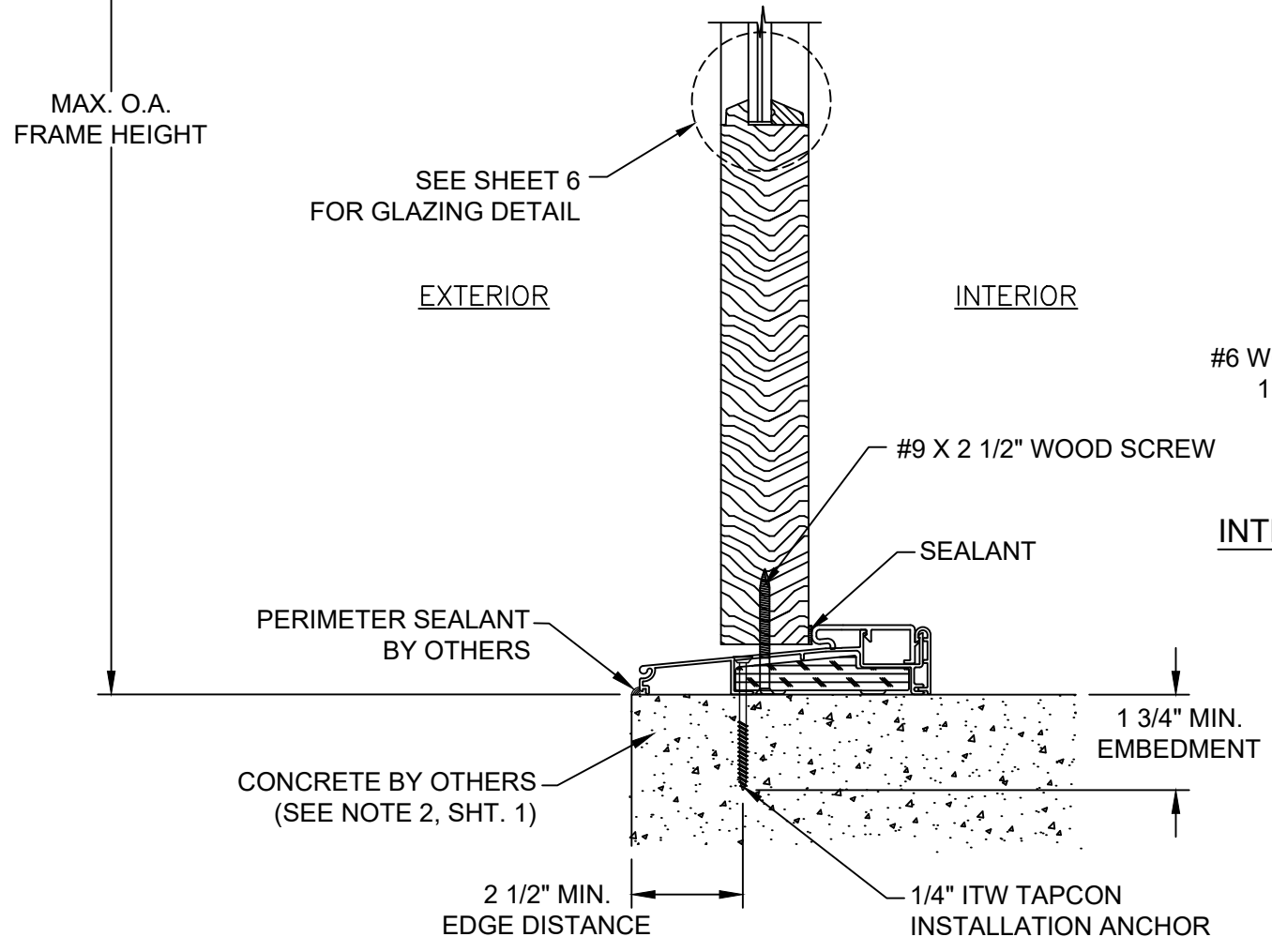

**A** VERTICAL SECTION  
CONCRETE SUBSTRATE

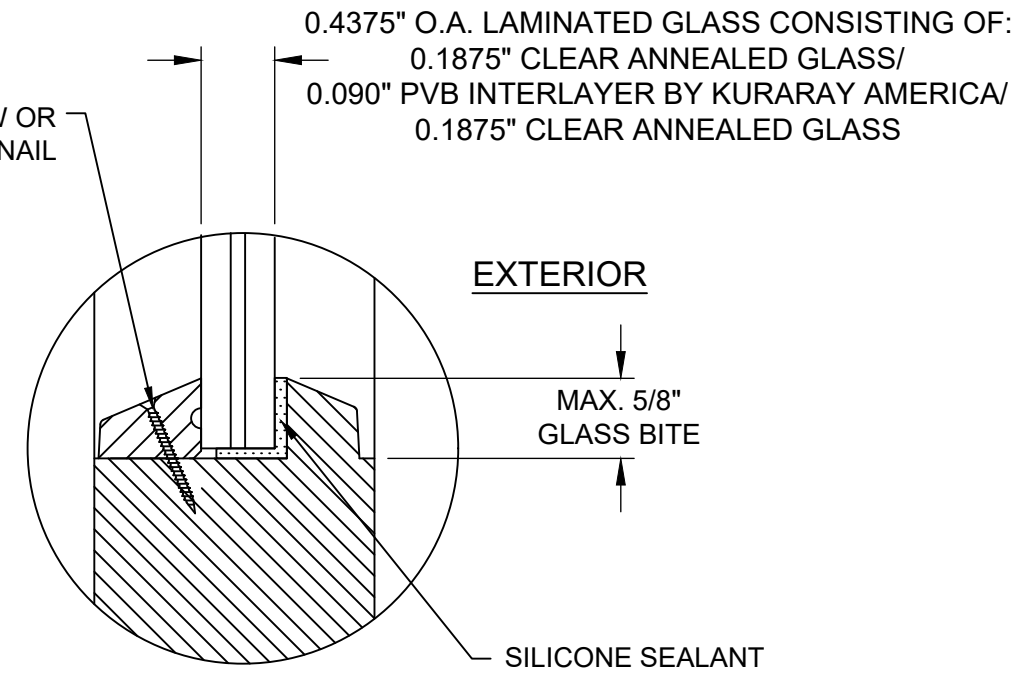

**GLAZING DETAIL**

PROJECT NO. 421-0102					

SIMPSON DOOR COMPANY  
400 SIMPSON AVE.  
MCCLEARY, WA 98557

TITLE: WESTAR HIGH IMPACT FIXED SINGLE SIDELITE  
VERTICAL SECTIONS & GLAZING DETAIL

PREPARED BY: RJA  
DRAWN BY: RJA  
SCALE: N.T.S.  
REV: ---

DATE: 6/8/21  
DRAWING NO: SIMP0016  
SHEET: 3 OF 4

PTC Product Design Group, LLC  
PO Box 320775  
Lubbock, TX 79407-0775  
FBPE CA NO. 25535

Robert J. Amoruso, P.E.  
Florida P.E. No. 49752

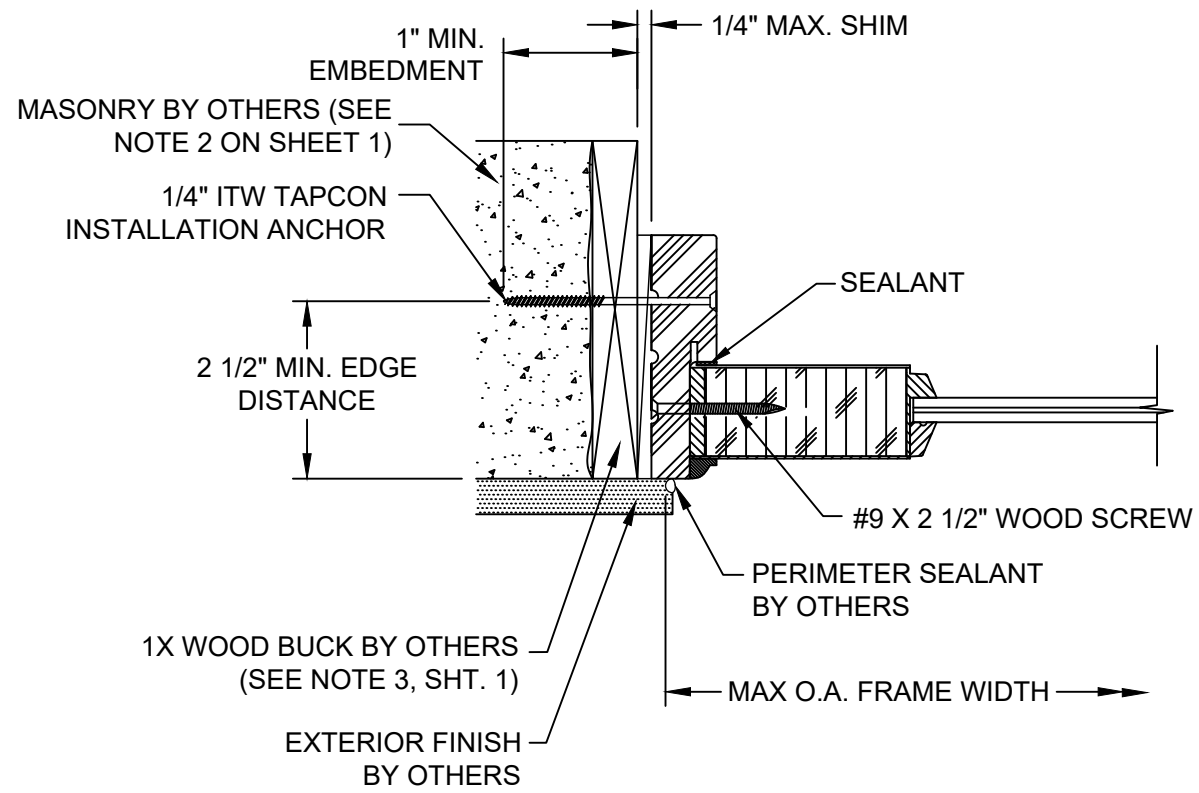

**D HORIZONTAL SECTION**  
MASONRY SUBSTRATE

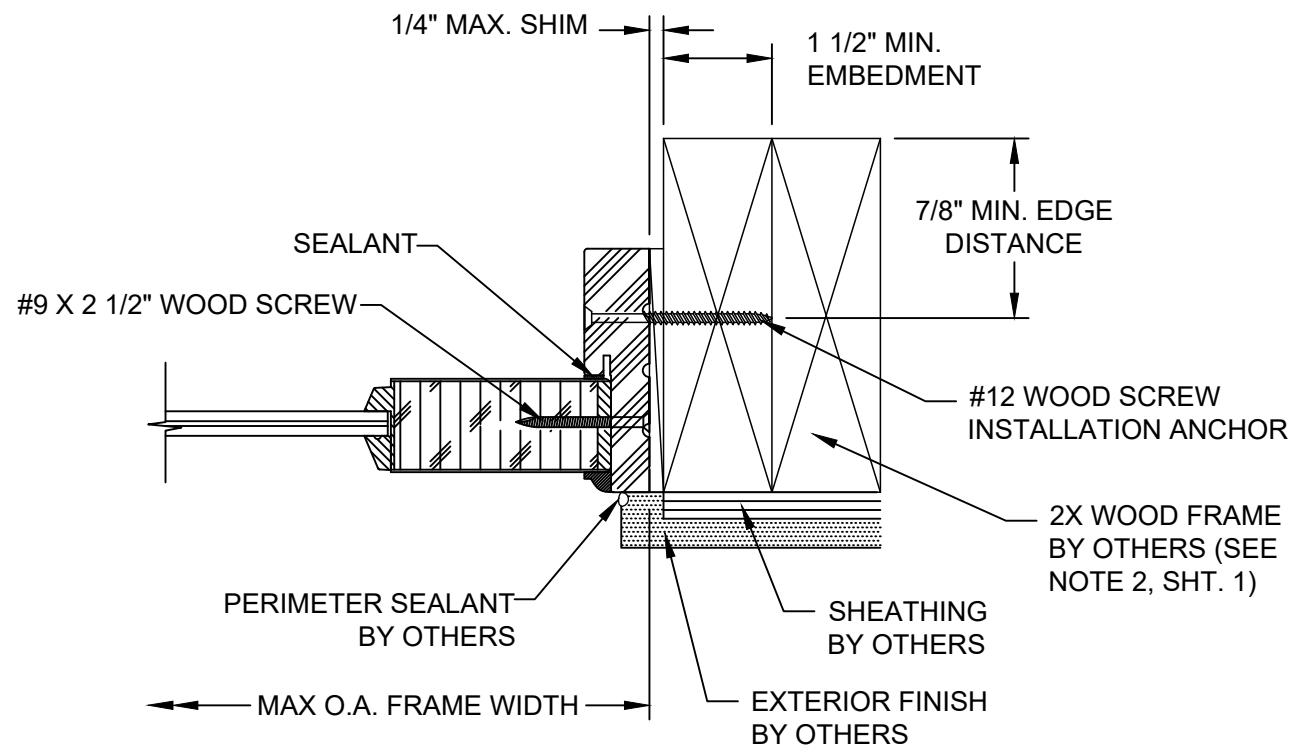

**E HORIZONTAL SECTION**  
WOOD FRAME SUBSTRATE

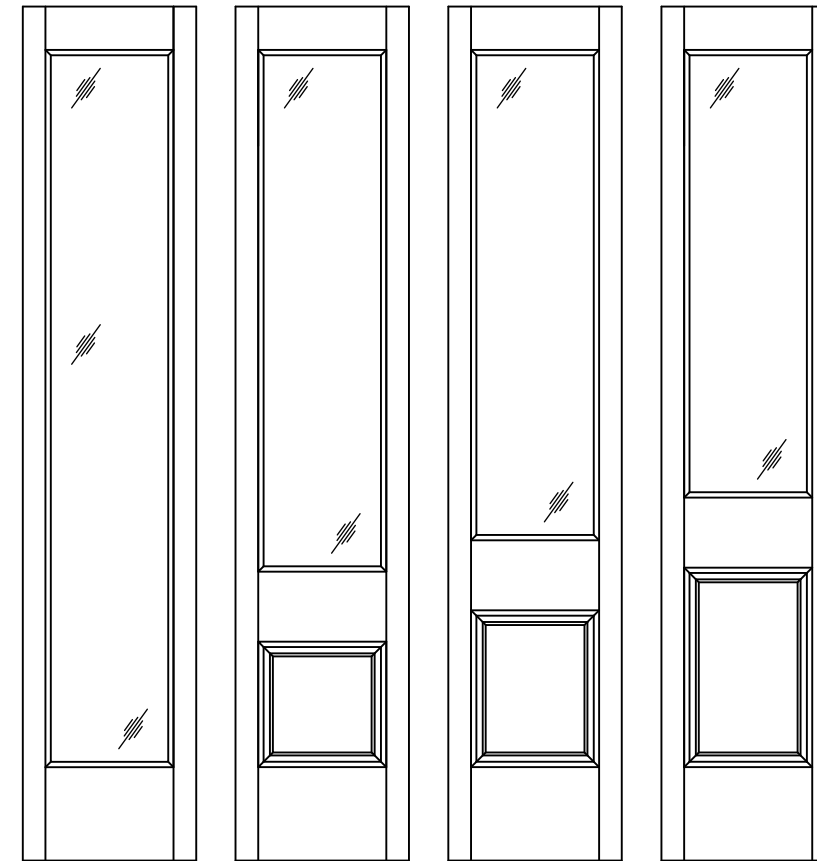

**APPLICABLE GLAZED PANELS**

NOTE:  
APPLIED MUNTINS USED FOR DIVIDED LITES, V-GROOVES  
OPTIONAL FOR BOTH FLAT AND RAISED PANELS.

PROJECT NO. 421-0102

SIMPSON DOOR COMPANY  
400 SIMPSON AVE.  
MCCLEARY, WA 98557

TITLE: WESTAR HIGH IMPACT FIXED SINGLE SIDELITE  
HORIZONTAL SECTIONS & QUALIFIED PANELS

PREPARED BY: RJA  
DRAWN BY: RJA  
SCALE: N.T.S.  
REV: ---

DATE: 6/8/21  
DRAWING NO.: SIMP0016  
SHEET: 4 OF 4

PTC Product Design Group, LLC  
PO Box 320775  
Lynchburg, VA 24502-0775  
FBPE C.A. NO. 25535  
Phone: 321.690.1788  
Fax: 321.690.1789  
Email: info@gdc-corp.com

Robert J. Amoruso, P.E.  
Florida P.E. No. 49752

