

# SIMONTON WINDOWS - 08-08 / 08-09 / 08-10 / 08-20 AWNING WINDOW w/SAFEPOINT IMPACT - MISSILE C



1 COCHRANE AVENUE  
PENNSBORO, WV 26415  
PH: 800-542-9118

**NOTES:**

- THIS INSTALLATION HAS BEEN EVALUATED FOR USE IN LOCATIONS ADHERING TO THE FLORIDA BUILDING CODES AND WHERE PRESSURE REQUIREMENTS AS DETERMINED BY ASCE 7 MINIMUM DESIGN LOADS FOR BUILDINGS AND OTHER STRUCTURES DO NOT EXCEED THE DESIGN PRESSURE RATINGS HEREIN, FOR USE OUTSIDE THE H.V.H.Z.
- THIS PRODUCT IS MISSILE LEVEL C, WIND ZONE 2 IMPACT RESISTANT. WHEN USED IN WINDOW ZONE 2 OR BELOW AREAS, THIS PRODUCT DOES NOT REQUIRE THE USE OF APPROVED IMPACT PROTECTIONS DEVICES (SHUTTERS).
- ALL INTERIOR AND EXTERIOR PERIMETER SURFACES OF THE WINDOW MUST BE CAULKED.
- ANCHOR TYPE, SIZE, SPACING, AND EMBEDMENT SHALL BE AS SPECIFIED IN THESE DRAWINGS. USE APPROPRIATE ANCHORAGE FROM TABLE I ACCORDING TO SUBSTRATE TYPE. A MINIMUM CENTER-TO-CENTER SPACING OF 3" SHALL BE MAINTAINED BETWEEN ALL INSTALLATION FASTENERS IN ANY DIRECTION. (EXCEPTION HARDWARE ANCHORS)
- ANCHOR EMBEDMENT TO SUBSTRATE SHALL BE BEYOND WALL DRESSING OR STUCCO. FOR MASONRY OPENINGS WITH WOOD BUCKS LESS THAN 1-1/2" THICK, EMBEDMENT SHALL BE BEYOND WOOD BUCKS. FOR CONCRETE/CMU OPENINGS EMBEDMENT SHALL BE BEYOND WOOD BUCKS, IF USED, AND INTO SUBSTRATE. WOOD BUCKS WITH MASONRY ARE OPTIONAL.
- ALL SCREWS SHALL HAVE MOD. TRUSS HEAD, PAN HEAD, FLAT HEAD OR INTEGRATED OR SEPARATE WASHERS, WITH .042" MIN. HEAD OR WASHER DIAMETER.
- WOOD, METAL, OR MASONRY OPENINGS, BUCKS, AND BUCK FASTENERS, BY OTHERS, SHALL BE PROPERLY DESIGNED AND INSTALLED BY OTHERS TO TRANSFER SUPERIMPOSED LOADS TO THE STRUCTURE. ADEQUACY OF THE STRUCTURE TO RECEIVED THESE LOADS SHALL BE VERIFIED BY THE CONTRACTOR OR AUTHORITY HAVING JURISDICTION (AHJ).
- IT IS THE RESPONSIBILITY OF THE ARCHITECT OR ENGINEER OF RECORD OR AS APPROVED BY THE AHJ TO SELECT SIMONTON PRODUCTS TO MEET ALL APPLICABLE LOCAL LAWS, BUILDING CODES, ORDINANCES, OR OTHER SAFETY REQUIREMENTS FOR EACH INSTALLATION.
- MAX. SHIM STACK IS 1/4", AND SHIMS SHOULD BE USED WHERE GAPS OF GREATER THAN 1/16" EXISTING BETWEEN THE OPENING AND FRAME IN THE FOLLOWING LOCATIONS: FOR THROUGH-FRAME AT EACH INSTALLATION ANCHOR, AND FOR FIN AT THE JAMBS MAX. 6" FROM CORNERS AND AT MID-SPAN. SHIMS SHALL BE LOAD-BEARING AND CAPABLE OF TRANSFERRING LOADS TO THE SUBSTRATE.
- SEALING AND FLASHING BY OTHERS SHOULD BE APPLIED USING THE ASTM E 2112 METHODOLOGY APPROPRIATE FOR THE OPENING INTO WHICH THE WINDOW IS BEING INSTALLED. OVERALL WATER PENETRATION RESISTANCE OF THE INSTALLED PRODUCT IS THE RESPONSIBILITY OF OTHERS.
- GLAZING SHALL COMPLY WITH ASTM E 1300.
- A WIND LOAD DURATION FACTOR  $C_d = 1.6$  WAS USED FOR THE ANALYSIS OF WOOD SCREWS ONLY.
- ALL FASTENERS PENETRATING INTO PRESSURE TREATED WOOD SHALL BE CAPABLE OF PREVENTING CORROSION DUE TO REACTION WITH PRESSURE TREATMENT CHEMICALS. ANY DISSIMILAR MATERIALS THAT COME INTO CONTACT SHALL BE PROTECTED TO PREVENT REACTIONS IN ACCORDANCE WITH CODE REQUIREMENTS.
- WINDOWS SHALL BE CONSTRUCTED AS SPECIFIED IN TEST REPORTS B2264.01-501-47 BY ARCHITECTURAL TESTING, INC AND I10-24281-I BY NATIONAL CERTIFIED TESTING LABORATORIES.
- DESIGNATION "X" IS FOR OPERABLE PANEL AND "O" IS FOR FIXED PANEL.
- USE A BACKER ROD ON ALL JOINTS  $>3/4"$ . FINISHED CAULK JOINT SHOULD BE A MINIMUM OF 3/8".

PRODUCT MODEL	OVERALL SIZE		PERFORMANCE RATING	DESIGN PRESSURE	INSTALLATION METHOD	MISSILE IMPACT RATING
	WIDTH	HEIGHT				
08-08   08-09   08/10   08-20	50"	36"	R-PG40	+40/-40 PSF	NAIL FIN	MISSILE C WIND ZONE 2
08-08   08-09   08/10   08-20	50"	36"	R-PG40	+40/-40 PSF	THROUGH FRAME	

SECTION	SHEET DESCRIPTION
1	NOTES, DESIGN PRESSURE & INSTALLATION FASTENER TABLES
2	ELEVATION & ANCHOR LAYOUTS
3	VERTICAL SECTIONS
4	HORIZONTAL SECTIONS & GLAZING DETAILS
5	BILL OF MATERIALS & COMPONENTS & BUCK ANCHORING

ID	SUBSTRATE TYPE	ANCHOR TYPE	MIN. EMBED.	MIN. EDGE DISTANCE
FIN INSTALLATION				
A	2X MIN. SPRUCE-PIN-FIR PINE WOOD (G=0.42)	MAIN FRAME: 10D ROOFING NAIL HARDWARE: #8 WOOD SCREW	2"	7/8"
B	2X MIN. SPRUCE-PIN-FIR PINE WOOD (G=0.42)	MAIN FRAME: #8 WOOD SCREW HARDWARE: #8 WOOD SCREW	1-1/2"	3/8"
C	1/6 GAUGE (0.060"), STEEL 36 KSI MIN. OR 1/8" ALUM. 6063-T5 MIN.	MAIN FRAME: #10 GRADE 5 SELF-TAPPING/DRILLING SCREW HAREWARE: #8 GRADE 5 SELF-TAPPING/DRILLING SCREW	FULL, PLUS 3 THREADS MIN.	3/8"
FRAME INSTALLATION				
D	CONCRETE (3.05 KSI MIN.)	MAIN FRAME OR HARDWARE: 3/16" ELCO ULTRACON OR DEWALT ULTRACON+	1-3/4"	1-1/8"
E	HOLLOW OR GROUT-FILLED CMU (ASTM C-90)	MAIN FRAME OR HARDWARE: 3/16" ELCO ULTRACON OR DEWALT ULTRACON+	1-1/4"	2-1/2"
F	2X MIN. SPRUCE-PIN-FIR PINE WOOD (G=0.42)	MAIN FRAME: #8 WOOD SCREW HARDWARE: #8 WOOD SCREW	1-3/8"	7/8"
G	1/6 GAUGE (0.060"), STEEL 36 KSI MIN. OR 1/8" ALUM. 6063-T5 MIN.	MAIN FRAME: #10 GRADE 5 SELF-TAPPING/DRILLING SCREW HAREWARE: #8 GRADE 5 SELF-TAPPING/DRILLING SCREW	FULL, PLUS 3 THREADS MIN.	1/2"

TITLE: 08-08/08-09/08-10/08-20 AWNING W/SAFEPOINT NOTES: DESIGN PRESSURE & INSTALLATION FASTENER TABLES	DATE	BY	REVISION DESCRIPTION	NO.
	07.23.21	LMH		
DWN BY:	CHK BY:	SCALE:		
LMH		NTS		

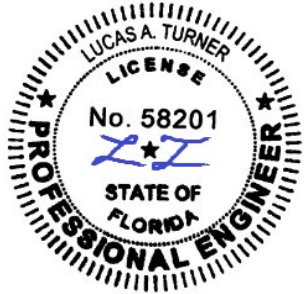

8/30/2021  
LUCAS A. TURNER, P.E.  
FL PE # 58201  
TURNER ENGINEERING & CONSULTING, INC.  
(COA # 29779)  
2428 OLD NATCHEZ TRACE TRAIL, CAMDEN, TN 38320  
PH. 941-380-1574

FL#: **39613**

DWG #: **IN0592FL**

SHEET **1-FL OF 4**



1 COCHRANE AVENUE  
 PENNSBORO, WV 26415  
 PH: 800-542-9118

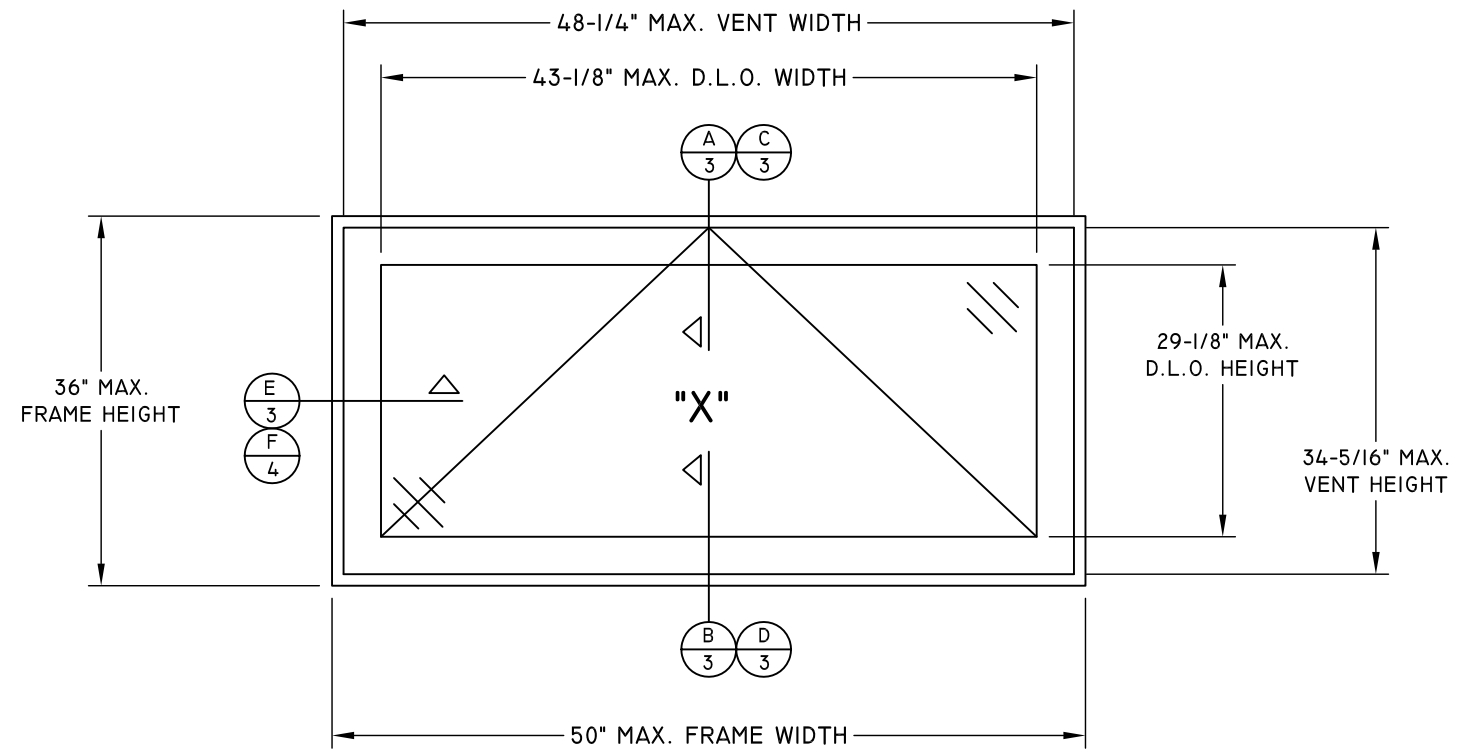

**ELEVATION VIEW**

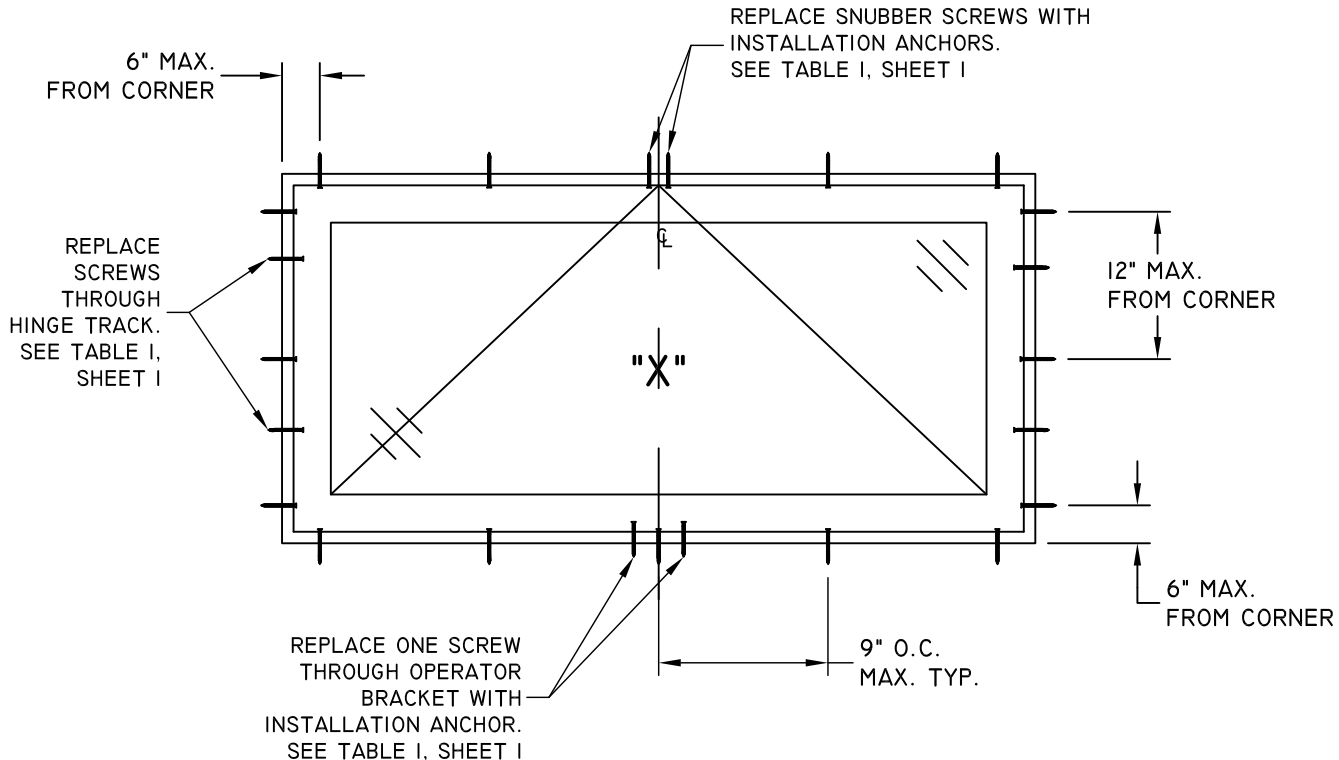

**ANCHOR LAYOUT  
 FINLESS**

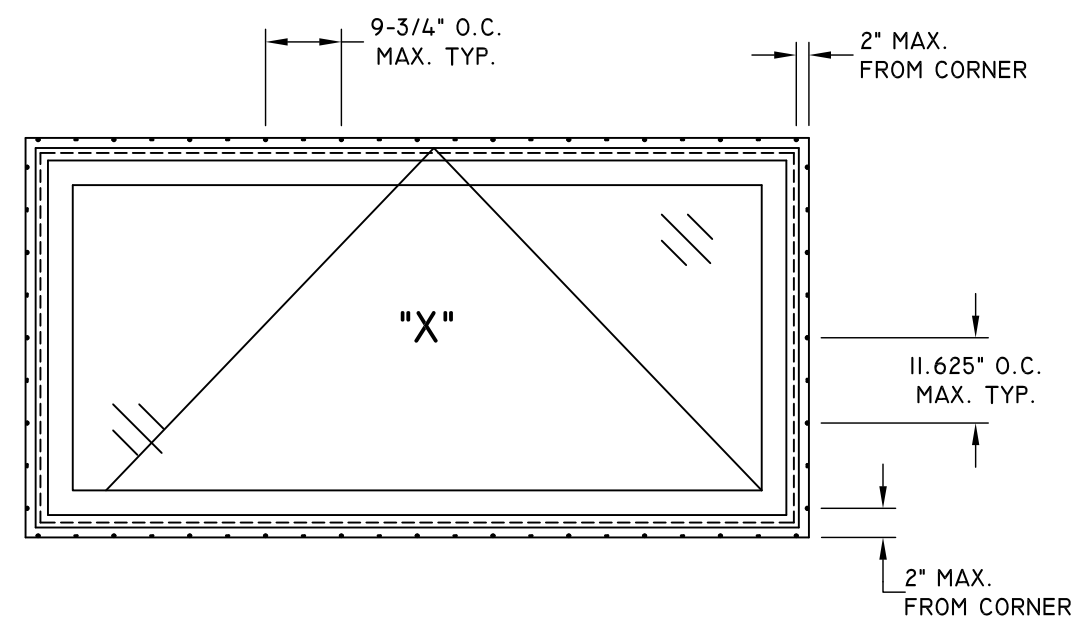

**ANCHOR LAYOUT  
 FIN**

TITLE: 08-08/08-09/08-10/08-20 AWNING W/SAFEPOINT ELEVATIONS AND ANCHOR LAYOUTS	DATE			
	BY			
NO.	REVISION DESCRIPTION			

DATE: 07.23.21	DWN BY: LMH	CHK BY:	SCALE: NTS
----------------	-------------	---------	------------



8/30/2021  
 LUCAS A. TURNER, P.E.  
 FL PE # 58201  
 TURNER ENGINEERING &  
 CONSULTING, INC.  
 (COA # 29779)  
 2428 OLD NATCHEZ TRACE  
 TRAIL, CAMDEN, TN 38320  
 PH. 941-380-1574

FL#: **39613**

DWG #: **IN0592**

SHEET: **2 OF 4**



1 COCHRANE AVENUE  
 PENNSBORO, WV 26415  
 PH: 800-542-9118

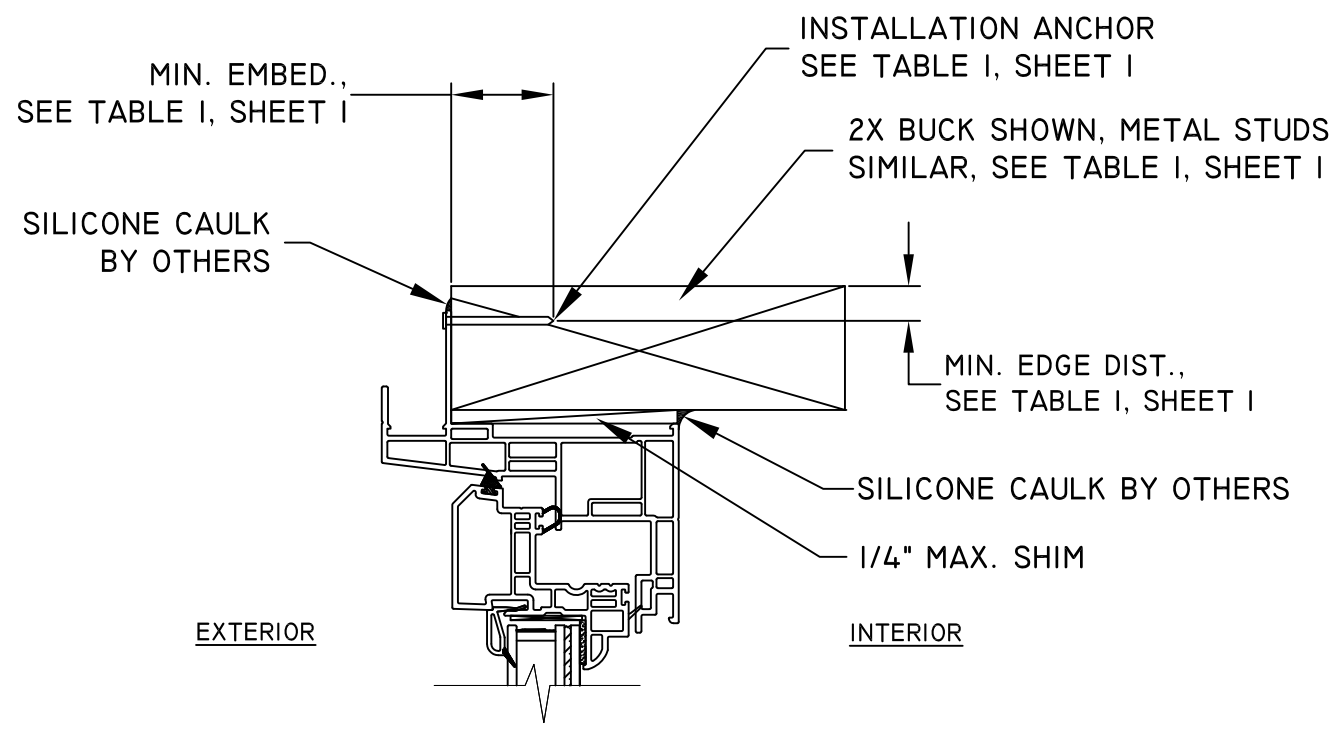

**A**  
**3**  
 VERTICAL SECTION  
 HEAD  
 FIN INSTALLATION

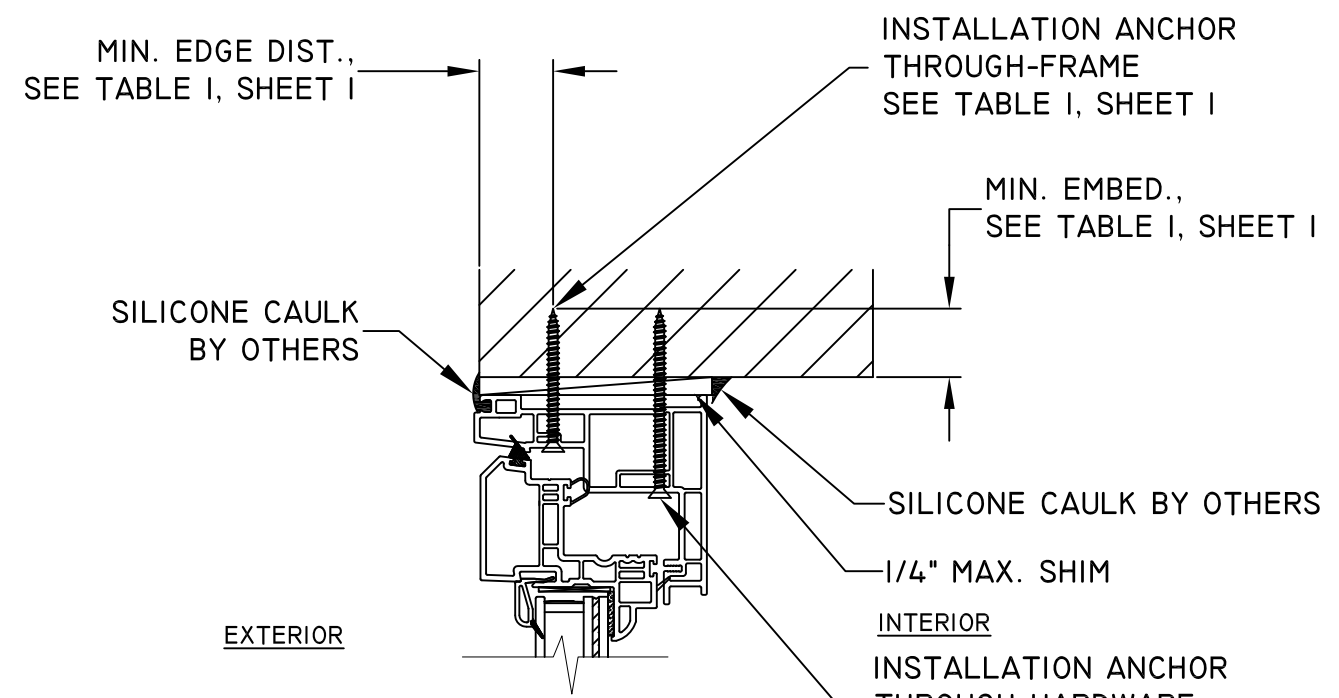

**C**  
**3**  
 VERTICAL SECTION  
 HEAD  
 FINLESS INSTALLATION

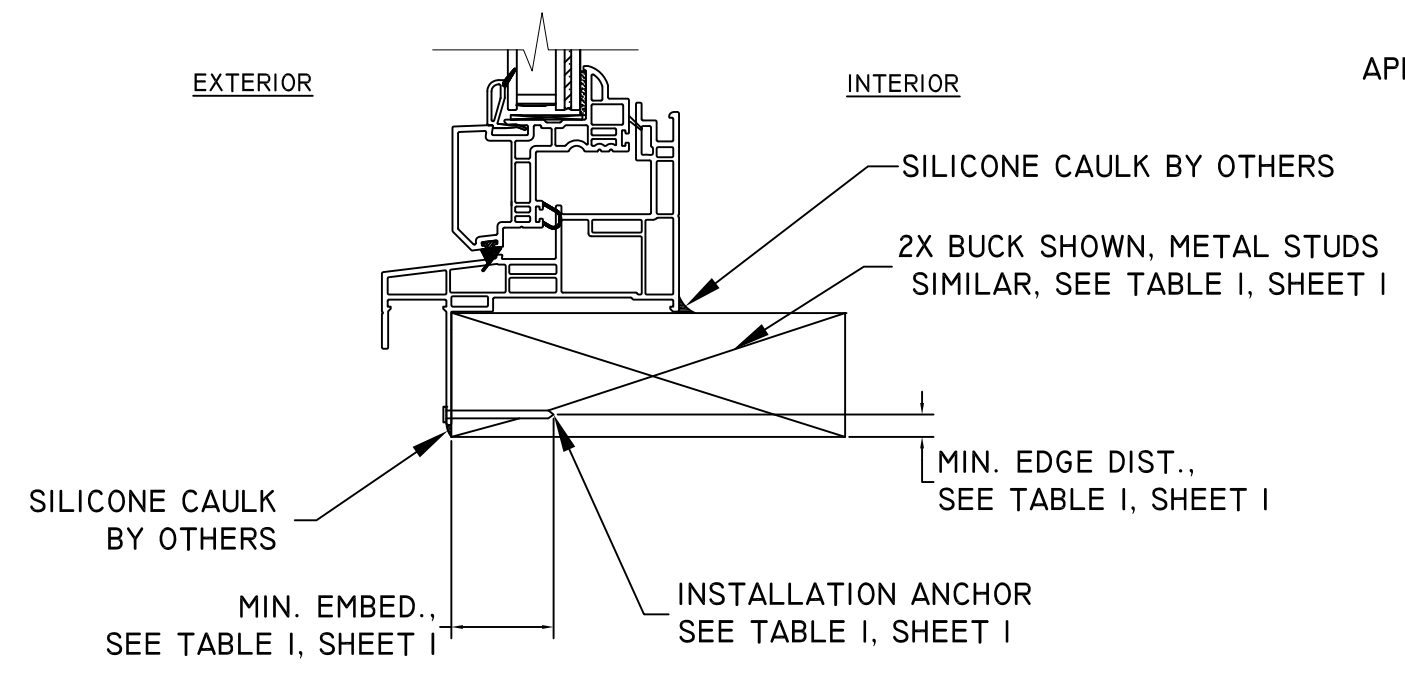

**B**  
**3**  
 VERTICAL SECTION  
 HEAD  
 FIN INSTALLATION

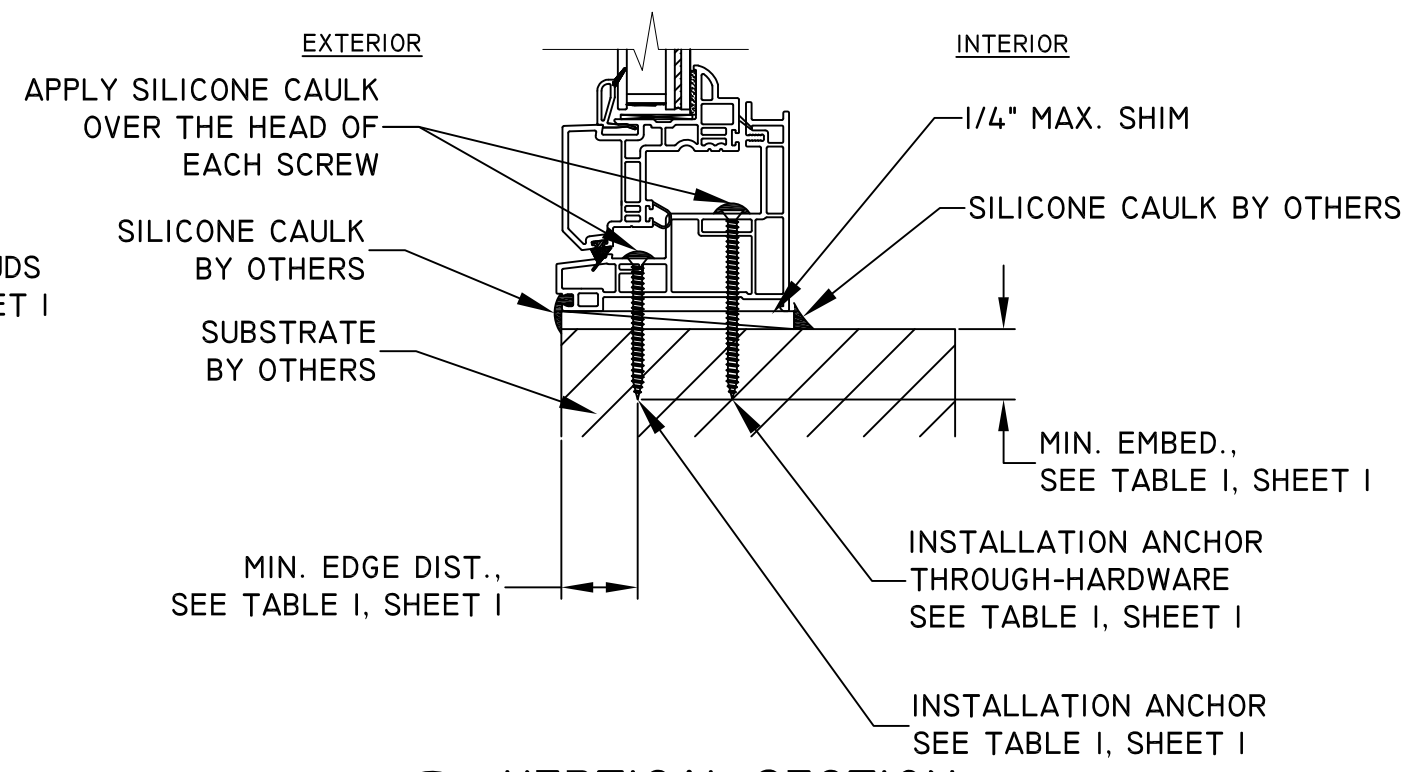

**D**  
**3**  
 VERTICAL SECTION  
 SILL  
 FINLESS INSTALLATION

TITLE: 08-08/08-09/08-10/08-20 AWNING W/SAFEPOINT VERTICAL SECTIONS

NO.	REVISION DESCRIPTION	BY	DATE

DATE: 07.23.21	DWN BY: LMH	CHK BY:	SCALE: NTS
-------------------	----------------	---------	---------------

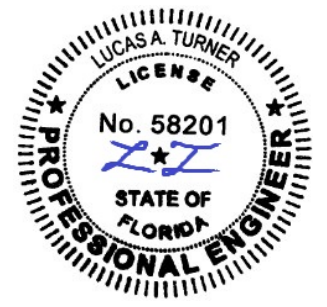

8/30/2021  
 LUCAS A. TURNER, P.E.  
 FL PE # 58201  
 TURNER ENGINEERING &  
 CONSULTING, INC.  
 (COA # 29779)  
 2428 OLD NATCHEZ TRACE  
 TRAIL, CAMDEN, TN 38320  
 PH. 941-380-1574

FL#: **39613**

DWG #: **IN0592**

SHEET: **3 OF 4**



1 COCHRANE AVENUE  
 PENNSBORO, WV 26415  
 PH: 800-542-9118

NO.	REVISION DESCRIPTION	BY	DATE

DATE: 07.23.21	DWN BY: LMH	CHK BY:	SCALE: NTS
-------------------	----------------	---------	---------------

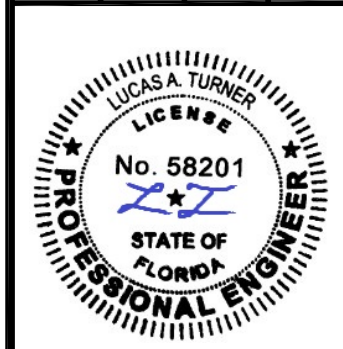

8/30/2021  
 LUCAS A. TURNER, P.E.  
 FL PE # 58201  
 TURNER ENGINEERING &  
 CONSULTING, INC.  
 (COA # 29779)  
 2428 OLD NATCHEZ TRACE  
 TRAIL, CAMDEN, TN 38320  
 PH. 941-380-1574

FL#: **39613**

DWG #: **IN0592**

SHEET: **4 OF 4**

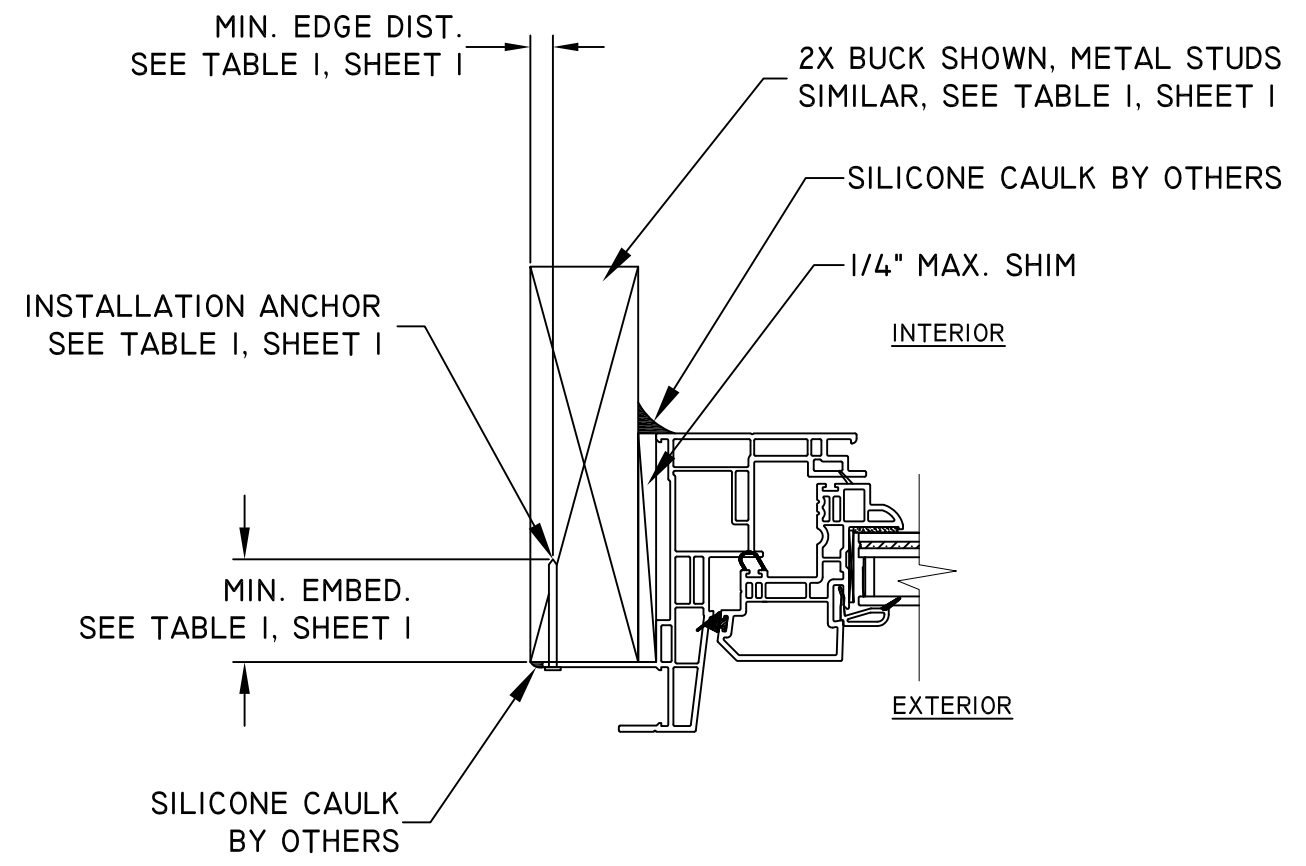

**E**  
4  
HORIZONTAL SECTION  
JAMB  
FIN INSTALLATION

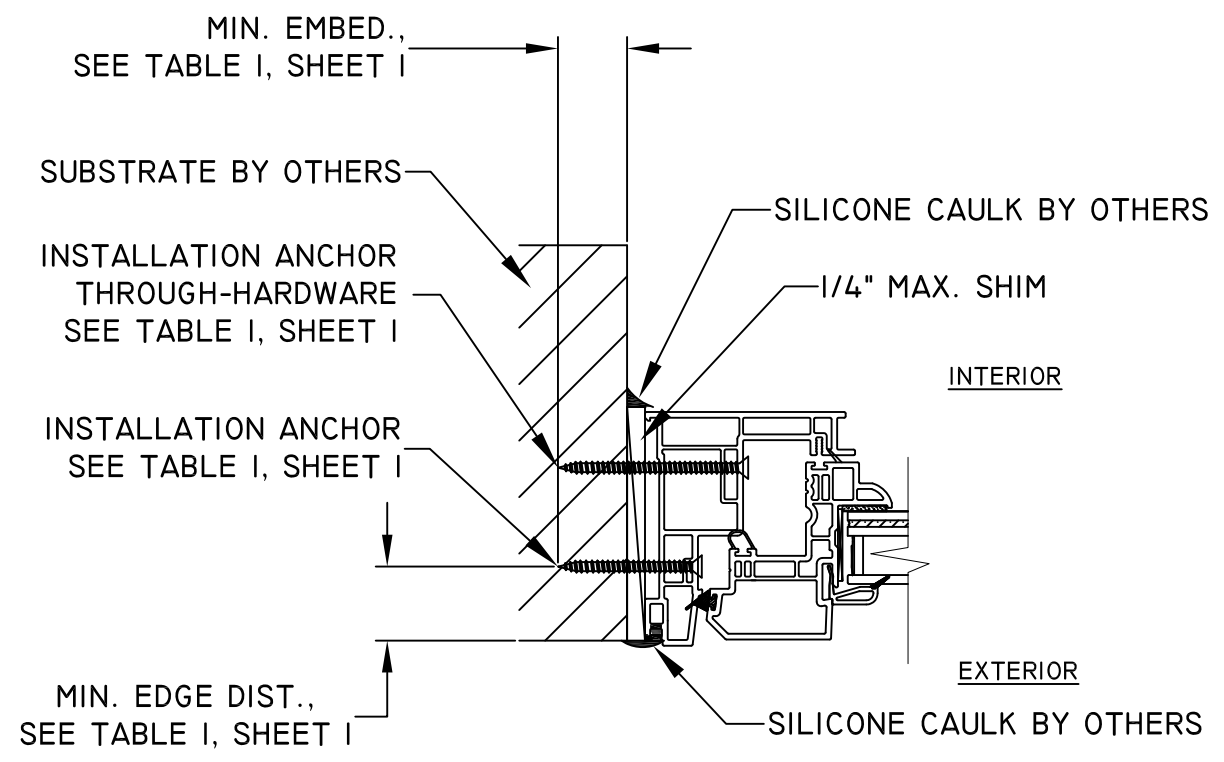

**F**  
4  
HORIZONTAL SECTION  
JAMB  
FINLESS INSTALLATION

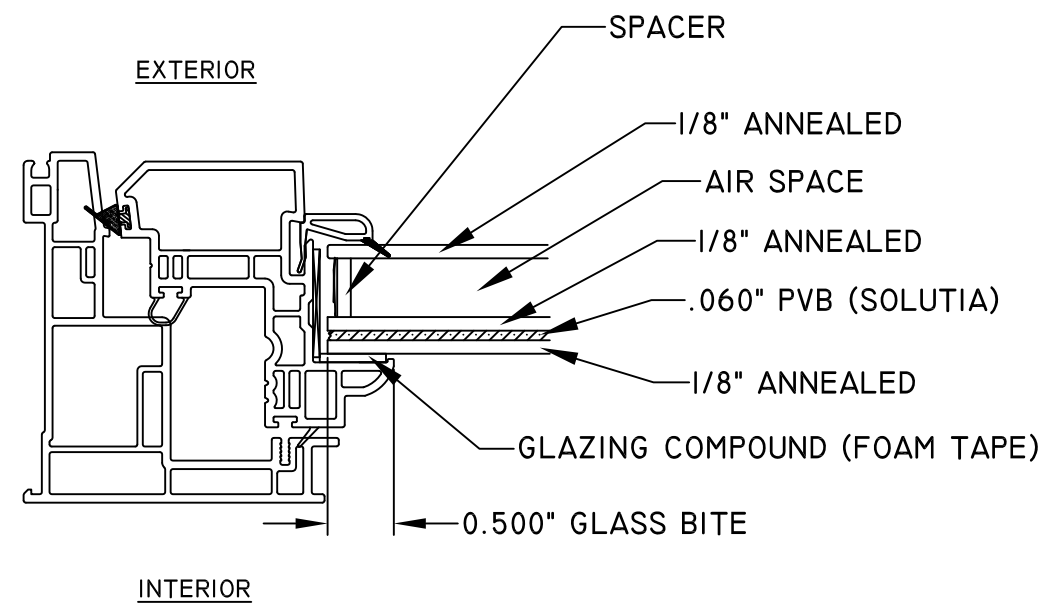

**1\"/>**

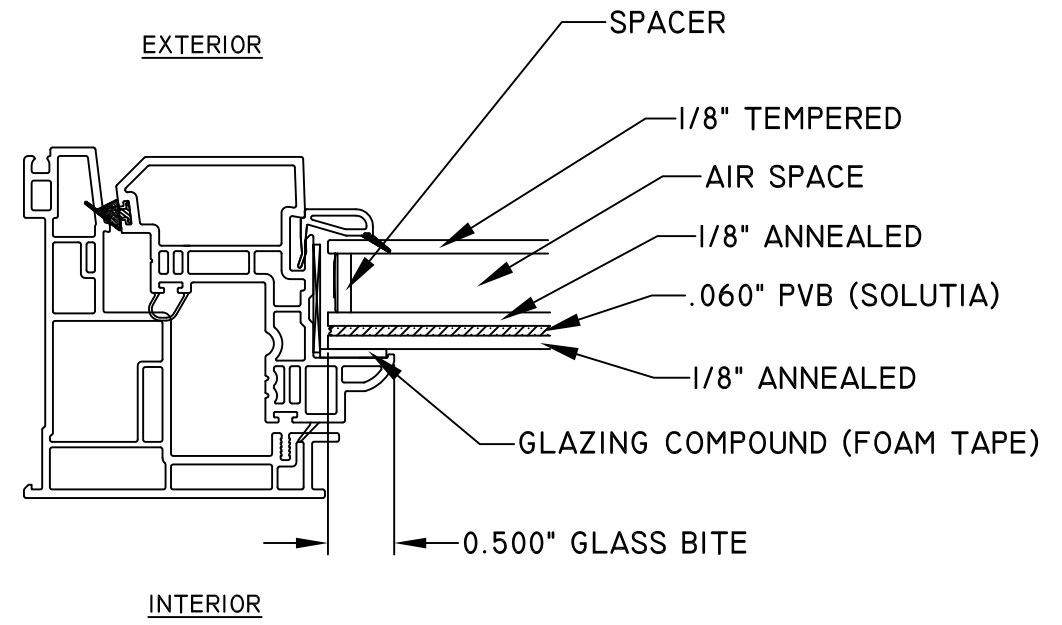

**1\"/>**