

HORIZONTAL SLIDER - NON-IMPACT

GENERAL NOTES:

1. THE PRODUCT SHOWN HEREIN IS DESIGNED AND MANUFACTURED TO COMPLY WITH THE FLORIDA BUILDING CODE (FBC), CURRENT EDITION AND IS RATED FOR USE IN THE HIGH VELOCITY HURRICANE ZONE (HVHZ).
2. GLAZING OPTIONS: (SEE SHEET 2)
3. CONFIGURATIONS: "OX", "XO".
4. DESIGN PRESSURE RATING (SEE SHEET 2):
 -NEGATIVE DESIGN LOADS BASED ON, TESTED PRESSURE AND GLASS TABLES ASTM E-1300-04e01/09.
 -POSITIVE DESIGN LOADS BASED ON, TESTED PRESSURE, WATER INFILTRATION TEST PRESSURE AND GLASS TABLES ASTM E-1300-04e01/09.
5. ANCHORAGE: THE 33 1/3% STRESS INCREASE HAS NOT BEEN USED IN THE DESIGN OF THIS PRODUCT. SEE SHEET 6 FOR ANCHOR DETAILS. WINDLOAD DURATION FACTOR Cd=1.6 WAS USED FOR WOOD ANCHOR CALCULATIONS.
6. NOT APPROVED FOR IMPACT RESISTANCE. IMPACT PROTECTIVE SYSTEM IS REQUIRED IN WIND BORNE DEBRIS REGION.
7. ALL FRAMES AND VENTS FULLY WELDED. SMALL JOINT SEAM SEALANT USED AT FIXED MEETING RAIL AND HEAD/SILL.
8. SERIES / MODEL DESIGNATION HS-8200.
9. THE DESIGNATION X AND O STAND FOR THE FOLLOWING:
 X = OPERABLE SASH, O = FIXED SASH
10. SECTION CALLOUTS APPLY TO ALL ELEVATIONS IN A SIMILAR LOCATION.
11. EXTERNAL WEEP SLOT = 1/4" x 1" LOCATED 6" FROM BOTH ENDS.



8200 PVC HORIZ. SLIDER NON-IMPACT

PROPRIETARY AND CONFIDENTIAL
 THE INFORMATION CONTAINED IN THIS DRAWING IS THE SOLE PROPERTY OF CUSTOM WINDOW SYSTEMS, INC. ANY REPRODUCTION IN PART OR AS A WHOLE WITHOUT THE WRITTEN PERMISSION OF CUSTOM WINDOW SYSTEMS, INC IS PROHIBITED.

FLORIDA APPROVAL NO.:

4092

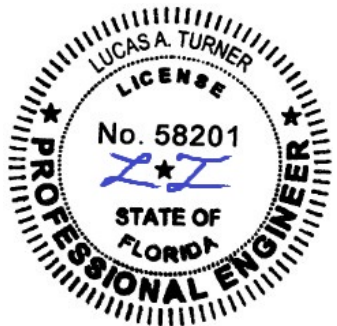

7/27/2023

LUCAS A. TURNER, P.E.
 FL PE # 58201
 Turner Engineering & Consulting, Inc.
 2428 Old Natchez Trc Trl
 Camden, TN 38320
 PH. 941-380-1574

SHEET DESCRIPTION:

GENERAL NOTES AND ELEVATIONS

DRAWN BY:	DATE:
ADE	10/13/11
DWG #:	REV.:
CWS-486E	E
SCALE:	SHEET
1:15	1 OF 6

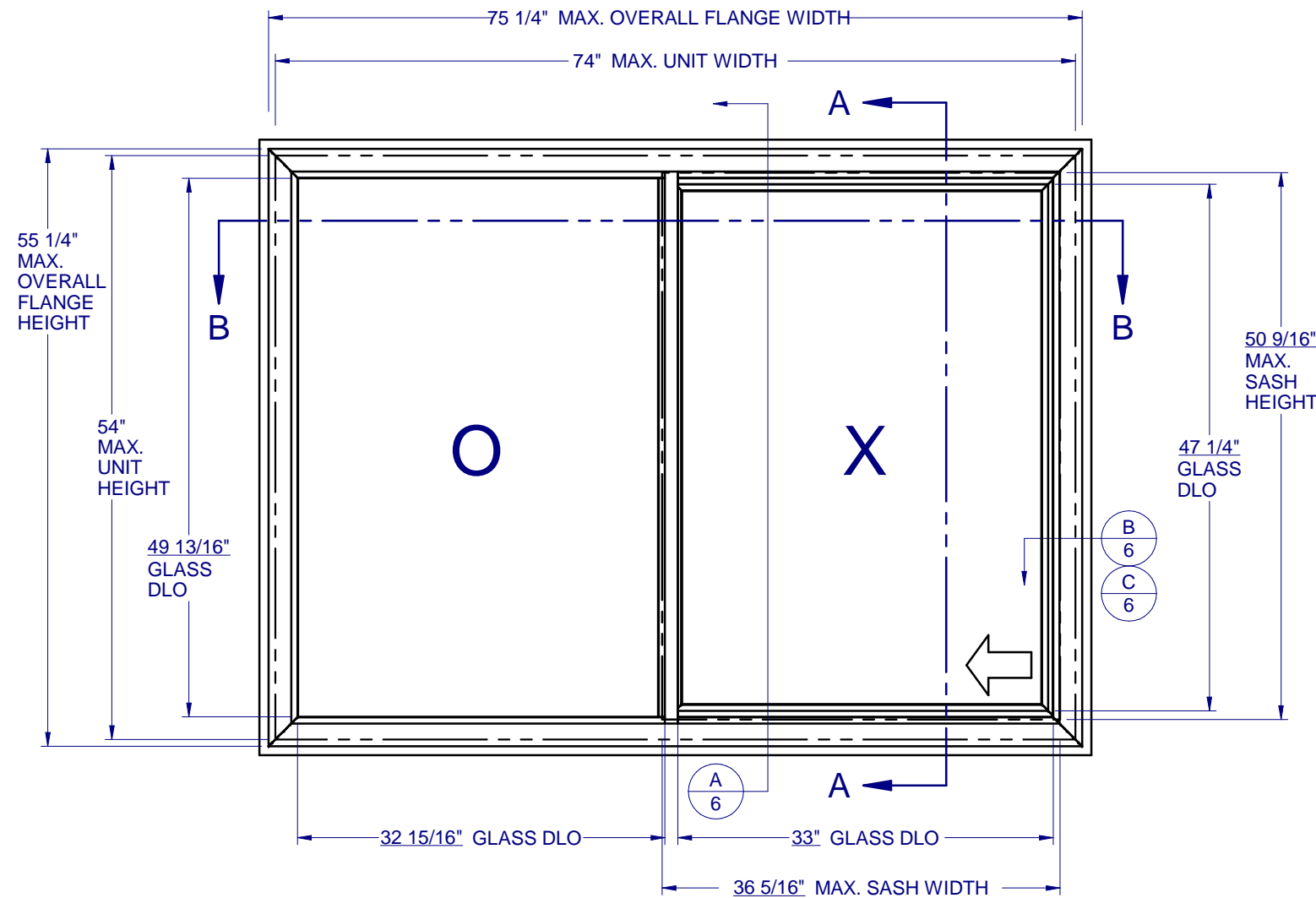

TABLE OF CONTENTS

GENERAL NOTES & ELEVATIONS.....	1
DP CHART & GLAZING DETAILS.....	2
SECTION VIEWS - OX.....	3
BOM & EXTRUSIONS.....	4
ANCHOR SCHEDULE & NOTES.....	5
INSTALLATION DETAILS.....	6

MAX. UNIT SIZE	DESIGN PRESSURE RATING	IMPACT RATING
74" x 54"	SEE COMPARATIVE ANALYSIS CHART, SHEET 2	NONE

DESIGN PRESSURES FOR EQUAL SPLIT "O/X" or "X/O" CONFIGURATION WITH GLASS TYPE A or B

Unit Width	Unit Height									
	19 1/2	23 1/2	27 1/2	31 1/2	35 1/2	39 1/2	43 1/2	47 1/2	51 1/2	54
27 1/2	+60.0 / -120.0	+60.0 / -120.0	+60.0 / -120.0	+60.0 / -120.0	+60.0 / -120.0	+60.0 / -120.0	+60.0 / -120.0	+60.0 / -120.0	+60.0 / -120.0	+60.0 / -120.0
29 1/2	+60.0 / -120.0	+60.0 / -120.0	+60.0 / -120.0	+60.0 / -120.0	+60.0 / -120.0	+60.0 / -120.0	+60.0 / -120.0	+60.0 / -120.0	+60.0 / -120.0	+60.0 / -120.0
31 1/2	+60.0 / -120.0	+60.0 / -120.0	+60.0 / -120.0	+60.0 / -120.0	+60.0 / -120.0	+60.0 / -120.0	+60.0 / -120.0	+60.0 / -120.0	+60.0 / -120.0	+60.0 / -117.5
35 1/2	+60.0 / -120.0	+60.0 / -120.0	+60.0 / -120.0	+60.0 / -120.0	+60.0 / -120.0	+60.0 / -120.0	+60.0 / -120.0	+60.0 / -120.0	+60.0 / -112.8	+60.0 / -106.6
37 1/2	+60.0 / -120.0	+60.0 / -120.0	+60.0 / -120.0	+60.0 / -120.0	+60.0 / -120.0	+60.0 / -120.0	+60.0 / -120.0	+60.0 / -119.4	+60.0 / -108.1	+60.0 / -102.0
39 1/2	+60.0 / -120.0	+60.0 / -120.0	+60.0 / -120.0	+60.0 / -120.0	+60.0 / -120.0	+60.0 / -120.0	+60.0 / -120.0	+60.0 / -114.9	+60.0 / -103.9	+60.0 / -98.0
41 1/2	+60.0 / -120.0	+60.0 / -120.0	+60.0 / -120.0	+60.0 / -120.0	+60.0 / -120.0	+60.0 / -120.0	+60.0 / -120.0	+60.0 / -110.8	+60.0 / -100.1	+60.0 / -94.3
43 1/2	+60.0 / -120.0	+60.0 / -120.0	+60.0 / -120.0	+60.0 / -120.0	+60.0 / -120.0	+60.0 / -120.0	+60.0 / -120.0	+60.0 / -107.2	+60.0 / -96.6	+60.0 / -91.0
47 1/2	+60.0 / -120.0	+60.0 / -120.0	+60.0 / -120.0	+60.0 / -120.0	+60.0 / -120.0	+60.0 / -120.0	+60.0 / -113.7	+60.0 / -100.9	+60.0 / -90.7	+60.0 / -85.3
49 1/2	+60.0 / -120.0	+60.0 / -120.0	+60.0 / -120.0	+60.0 / -120.0	+60.0 / -120.0	+60.0 / -120.0	+60.0 / -110.8	+60.0 / -98.2	+60.0 / -88.2	+60.0 / -82.9
51 1/2	+60.0 / -120.0	+60.0 / -120.0	+60.0 / -120.0	+60.0 / -120.0	+60.0 / -120.0	+60.0 / -120.0	+60.0 / -108.3	+60.0 / -95.8	+60.0 / -85.8	+60.0 / -80.6
53 1/2	+60.0 / -120.0	+60.0 / -120.0	+60.0 / -120.0	+60.0 / -120.0	+60.0 / -120.0	+60.0 / -120.0	+60.0 / -105.9	+60.0 / -93.5	+60.0 / -83.7	+60.0 / -78.6
55 1/2	+60.0 / -120.0	+60.0 / -118.3	+60.0 / -115.6	+60.0 / -115.6	+60.0 / -115.6	+60.0 / -115.6	+60.0 / -103.9	+60.0 / -91.5	+60.0 / -81.8	+60.0 / -76.7
59 1/2	+60.0 / -114.1	+60.0 / -105.2	+60.0 / -101.1	+60.0 / -100.5	+60.0 / -100.5	+60.0 / -100.5	+60.0 / -100.3	+60.0 / -88.0	+60.0 / -78.4	+60.0 / -73.4
61 1/2	+60.0 / -108.7	+60.0 / -99.6	+60.0 / -95.2	+60.0 / -94.1	+60.0 / -94.1	+60.0 / -94.1	+60.0 / -94.1	+60.0 / -86.4	+60.0 / -76.9	+60.0 / -71.9
63 1/2	+60.0 / -103.7	+60.0 / -94.7	+60.0 / -89.9	+60.0 / -88.3	+60.0 / -88.3	+60.0 / -88.3	+60.0 / -88.3	+60.0 / -85.0	+60.0 / -75.5	+60.0 / -70.5
65 1/2	+60.0 / -99.2	+60.0 / -89.9	+60.0 / -84.9	+60.0 / -82.8	+60.0 / -82.7	+60.0 / -82.7	+60.0 / -82.7	+60.0 / -82.7	+60.0 / -74.2	+60.0 / -69.2
67 1/2	+60.0 / -95.1	+60.0 / -86.1	+60.0 / -80.9	+60.0 / -78.5	+60.0 / -78.1	+60.0 / -78.1	+60.0 / -78.1	+60.0 / -78.1	+60.0 / -73.1	+60.0 / -68.1
71 1/2	+60.0 / -87.8	+60.0 / -78.9	+60.0 / -73.5	+60.0 / -70.6	+60.0 / -69.6	+60.0 / -69.6	+60.0 / -69.6	+60.0 / -69.6	+60.0 / -69.6	+60.0 / -66.1
74	+60.0 / -83.7	+60.0 / -75.0	+60.0 / -69.6	+60.0 / -66.5	+60.0 / -65.1	+60.0 / -65.0	+60.0 / -65.0	+60.0 / -65.0	+60.0 / -65.0	+60.0 / -65.0

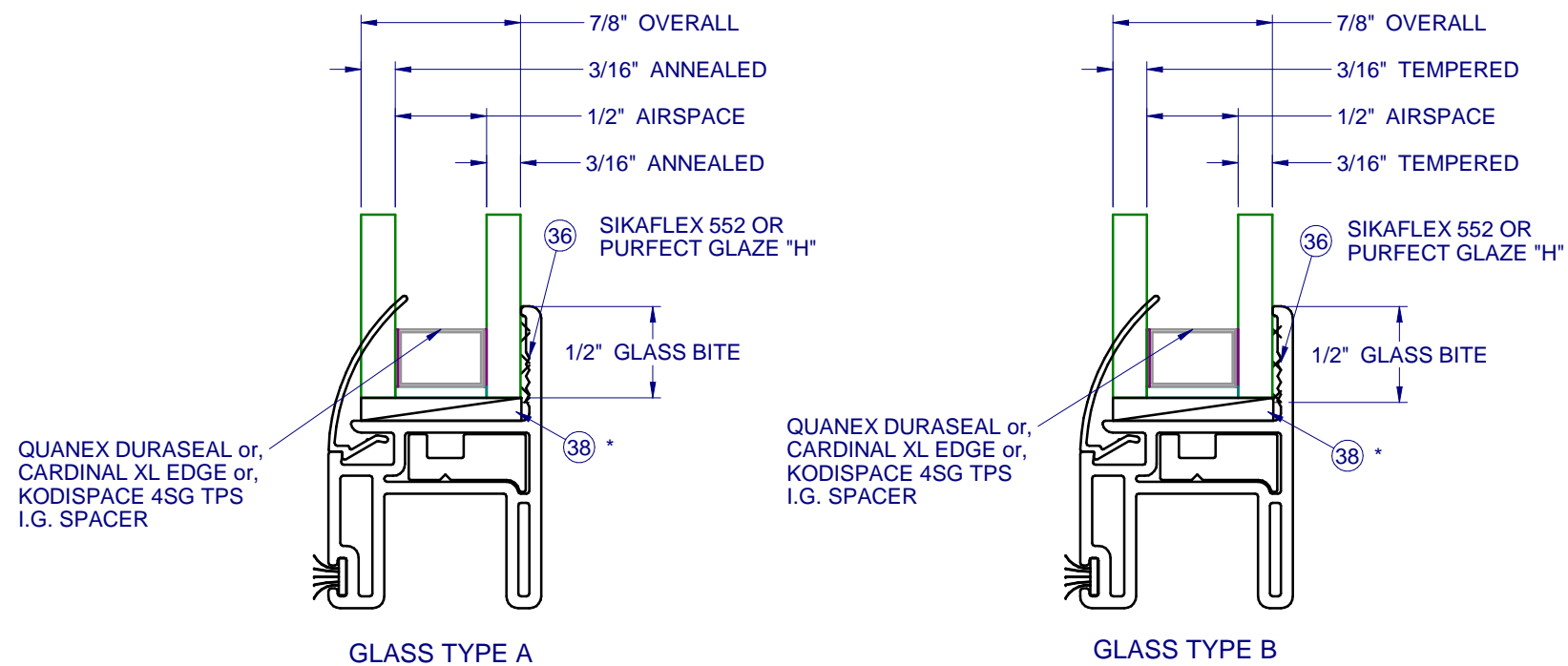

NOTE: IF SIZE INTENDED IS NOT SHOWN, USE NEXT LARGER SIZE

**8200 PVC
HORIZ. SLIDER
NON-IMPACT**

PROPRIETARY AND CONFIDENTIAL
THE INFORMATION CONTAINED IN
THIS DRAWING IS THE SOLE
PROPERTY OF CUSTOM WINDOW
SYSTEMS, INC. ANY
REPRODUCTION IN PART OR AS A
WHOLE WITHOUT THE WRITTEN
PERMISSION OF CUSTOM WINDOW
SYSTEMS, INC IS PROHIBITED.

FLORIDA APPROVAL NO.:
4092

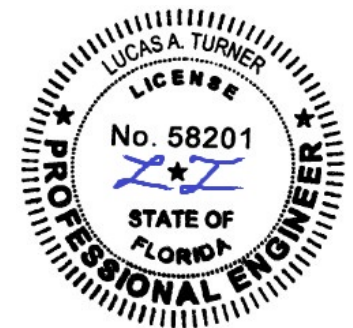

7/27/2023

LUCAS A. TURNER, P.E.
FL PE # 58201
Turner Engineering &
Consulting, Inc.
2428 Old Natchez Trc Trl
Camden, TN 38320
PH. 941-380-1574

SHEET DESCRIPTION:

**DP CHART AND
GLAZING DETAILS**

DRAWN BY: ADE	DATE: 10/13/11
DWG #: CWS-486E	REV.: E
SCALE: 1:1	SHEET 2 OF 6



1900 SW 44TH AVE.
OCALA, FLORIDA 34474
WWW.CWS.CC

**8200 PVC
HORIZ. SLIDER
NON-IMPACT**

PROPRIETARY AND CONFIDENTIAL
THE INFORMATION CONTAINED IN
THIS DRAWING IS THE SOLE
PROPERTY OF CUSTOM WINDOW
SYSTEMS, INC. ANY
REPRODUCTION IN PART OR AS A
WHOLE WITHOUT THE WRITTEN
PERMISSION OF CUSTOM WINDOW
SYSTEMS, INC IS PROHIBITED.

FLORIDA APPROVAL NO.:

4092



7/27/2023

LUCAS A. TURNER, P.E.
FL PE # 58201
Turner Engineering &
Consulting, Inc.
2428 Old Natchez Trc Trl
Camden, TN 38320
PH. 941-380-1574

SHEET DESCRIPTION:

SECTION VIEWS - OX

DRAWN BY:	DATE:
ADE	10/13/11
DWG #:	REV.:
CWS-486E	E
SCALE:	SHEET
1:2	3 OF 6

INTERIOR

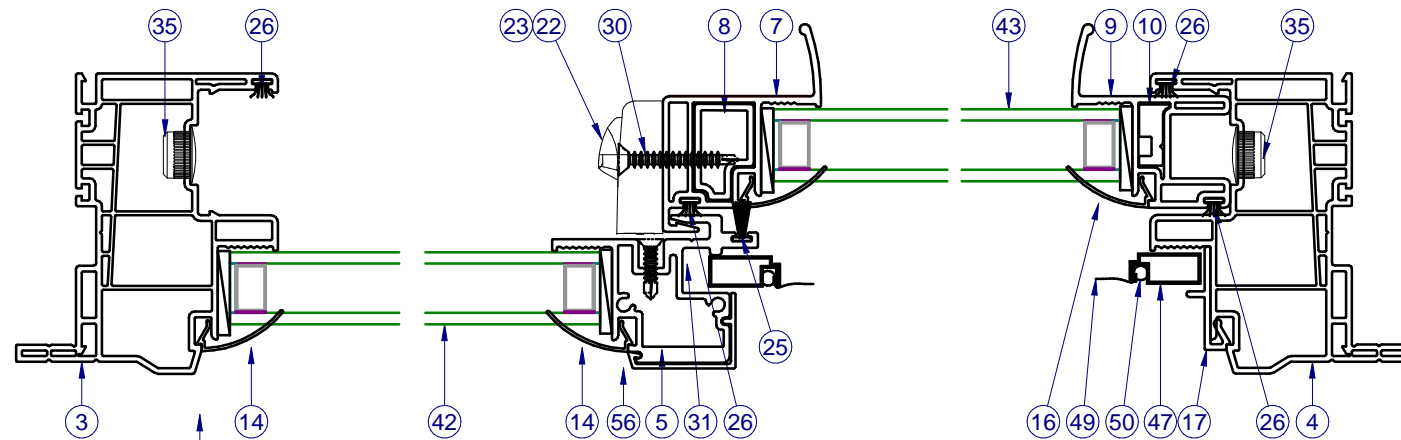

SECTION VIEW B-B

NOTE: FIXED LITE AT HEAD
AND SILL IS SIMILAR.

INTERIOR

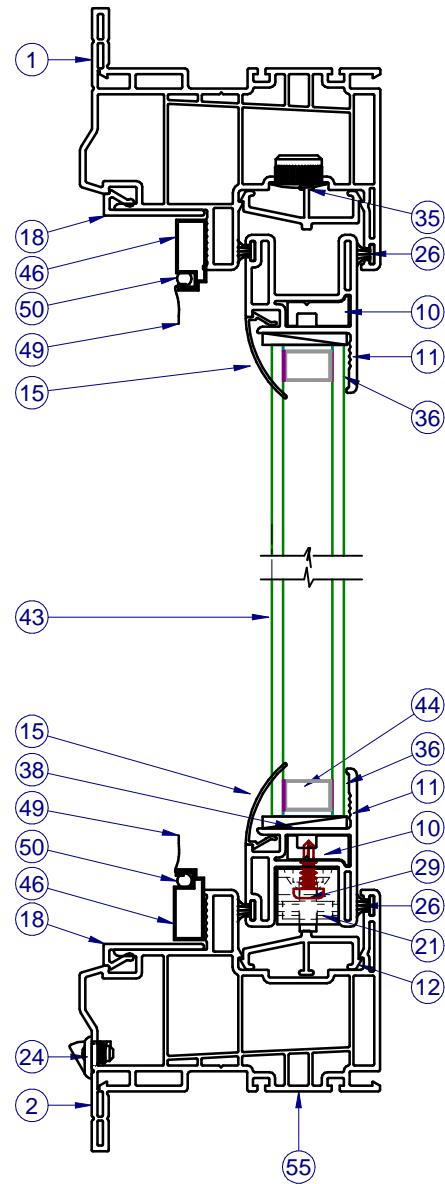

SECTION VIEW A-A

NOTE: ITEMS NOT SHOWN FOR CLARITY:
17, 25, 27, 34, 39, 40, 41, 48, 51, 52

PARTS LIST			
ITEM	PART #	DESCRIPTION	MATERIAL
1	H-6222	Main Fr., SH, w/Flg., PVC, Head	PVC
2	H-6222	Main Fr., SH, w/Flg., PVC, Sill	PVC
3	H-6222	Main Fr., SH, w/Flg., PVC, L. Jb.	PVC
4	H-6222	Main Fr., SH, w/Flg., PVC, R. Jb.	PVC
5	H-2121	Meet. Rail, Fxd.	Alum
7	H-6224	Sash Meet. Rail, PVC	PVC
8	H-2124	Reinf. Sash Meet. Rail	Alum
9	H-6223	Sash Bottom Rail, PVC (S.S.R. for HS)	PVC
10	S-2129	Reinf. S.B.R./S.S.R/S.T.R.	Alum
11	H-6225	Sash Top/Bot. Rail	PVC
12	S-1776	Roller track	Alum
13	S-6237	Glz. Bd., 7/8", Fxd., Horiz.	PVC
14	S-6237	Glz. Bd., 7/8", Fxd., Vert.	PVC
15	S-6237	Glz. Bd., 7/8", Sash, Horiz.	PVC
16	S-6237	Glz. Bd., 7/8", Sash, Vert.	PVC
17	S-6226	Scm. Adapt., w/ Nib, PVC	PVC
18	S-6227	Scm. Adapt., PVC	PVC
21	P-5241	Roller, Tandem	Nylon
22	P-3783	Lock, Impact, PVC	Zinc
23	P-4069	Keeper, Impact, PVC	Zinc
24	P-4479	Weep Cover w/ Flap	Nylon
25	P-4959	Wstp., 0.420 x .187 back FinSeal, Gray	
26	P-3429	Wstp., 0.270 x .187 back FinSeal, Gray	
27	P-3539	#8 x 0.75" Ph PH Tek	Steel
29	P-3511	#8 x 0.625" Ph PH Tek	Steel
30	P-4051W	#8 x 1.250" Ph FH TEK, Wht.	Steel
31	P-3541W	#8 x 0.500" Quad FH TEK, Wht.	Steel
34	P-3342	Seam Sealer, SM-5504	Silicone
35	P-5588	Cap Plug, 1/2" Hole	Nylon
36	P-4648	Purfect Glaze "H", Sika Flex 552	Silicone
38	P-5612	Set. Blk., 85 Dur., 1/8" x 7/8" x 1.5" Lg.	Rubber
42	Fixed	SEE SHEET 2	
43	Sash	SEE SHEET 2	
44		Spacer, See SHT 2	
46	P-3218	Screen Frame, Horiz.	RollForm
47	P-3218	Screen Frame, Vert.	RollForm
48	P-4754	Screen Frame Corner Key	Nylon
49	P-3581	Screen Cloth, 18 x 16 Fiberglass	
50	P-5576	Screen Spline, .155 Dia., Blk.	
51	P-3029	Screen Pull Tab	
52	P-3195	Screen Spring, SS	
58	P-4638	#8 x 2 1/2", PH, Modified Truss, TEK2	Steel

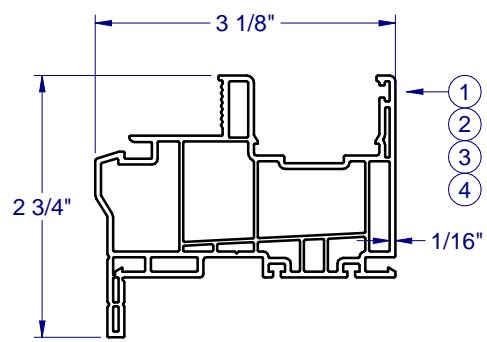

PVC FRAME FLANGE
H-6222

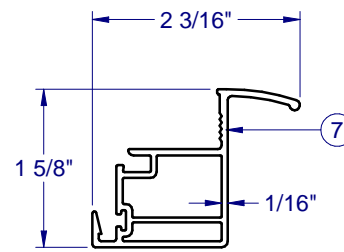

PVC SASH MTG RAIL
H-6224

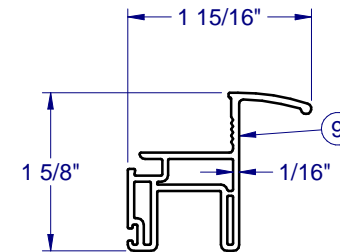

PVC SASH PULL
RAIL/STILE
H-6223

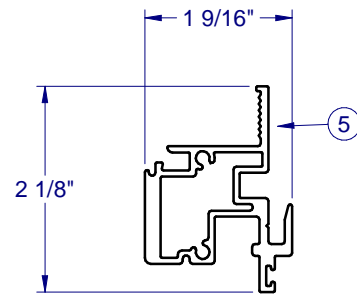

MTG RAIL
H-2121

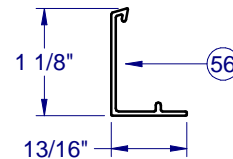

PVC MTG RAIL COVER
S-6228

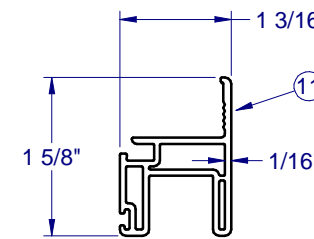

PVC SASH RAIL/STILE
H-6225

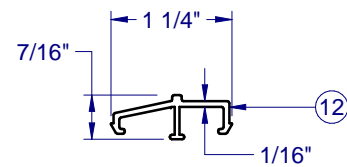

ROLLER TRACK
S-1776

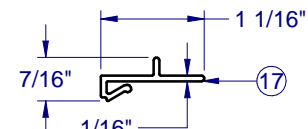

PVC SCREEN CATCH
S-6226

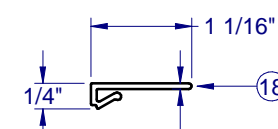

PVC SCREEN SUPPORT
S-6227

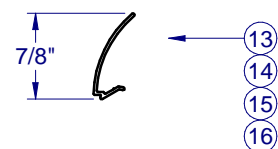

PVC GLAZING BEAD
S-6237

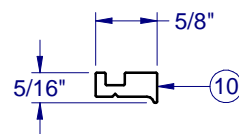

REINF. SBR/SSR
S-2129

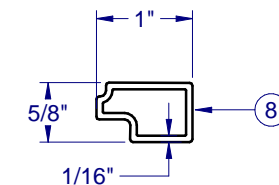

REINF. SASH MTG RAIL
H-2124

CORNER CONSTRUCTION

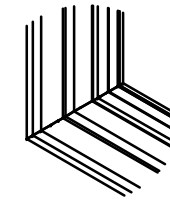

CORNER WELD
(ALL SIDES)
1:8

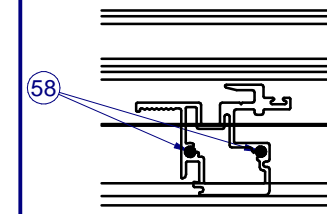

FIXED MEETING RAIL
SCREWED TOGETHER WITH
OUTERFRAME
1:8



1900 SW 44TH AVE.
OCALA, FLORIDA 34474
WWW.CWS.CC

8200 PVC
HORIZ. SLIDER
NON-IMPACT

PROPRIETARY AND CONFIDENTIAL
THE INFORMATION CONTAINED IN
THIS DRAWING IS THE SOLE
PROPERTY OF CUSTOM WINDOW
SYSTEMS, INC. ANY
REPRODUCTION IN PART OR AS A
WHOLE WITHOUT THE WRITTEN
PERMISSION OF CUSTOM WINDOW
SYSTEMS, INC IS PROHIBITED.

FLORIDA APPROVAL NO.:

4092

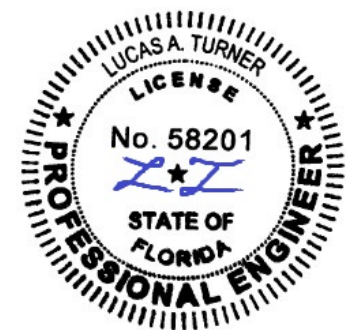

7/27/2023

LUCAS A. TURNER, P.E.
FL PE # 58201
Turner Engineering &
Consulting, Inc.
2428 Old Natchez Trc Trl
Camden, TN 38320
PH. 941-380-1574

SHEET DESCRIPTION:

BOM AND EXTRUSIONS

DRAWN BY:	DATE:
ADE	10/13/11
DWG #:	REV.:
CWS-486E	E
SCALE:	SHEET
1:2	4 OF 6

LINE ITEMS NOT USED:
6, 19-20, 25, 28, 32-33, 37, 39-41, 45, 53-54

NOTE: ALL ALUMINUM EXTRUSIONS ARE 6063-T6 UNLESS OTHERWISE NOTED.

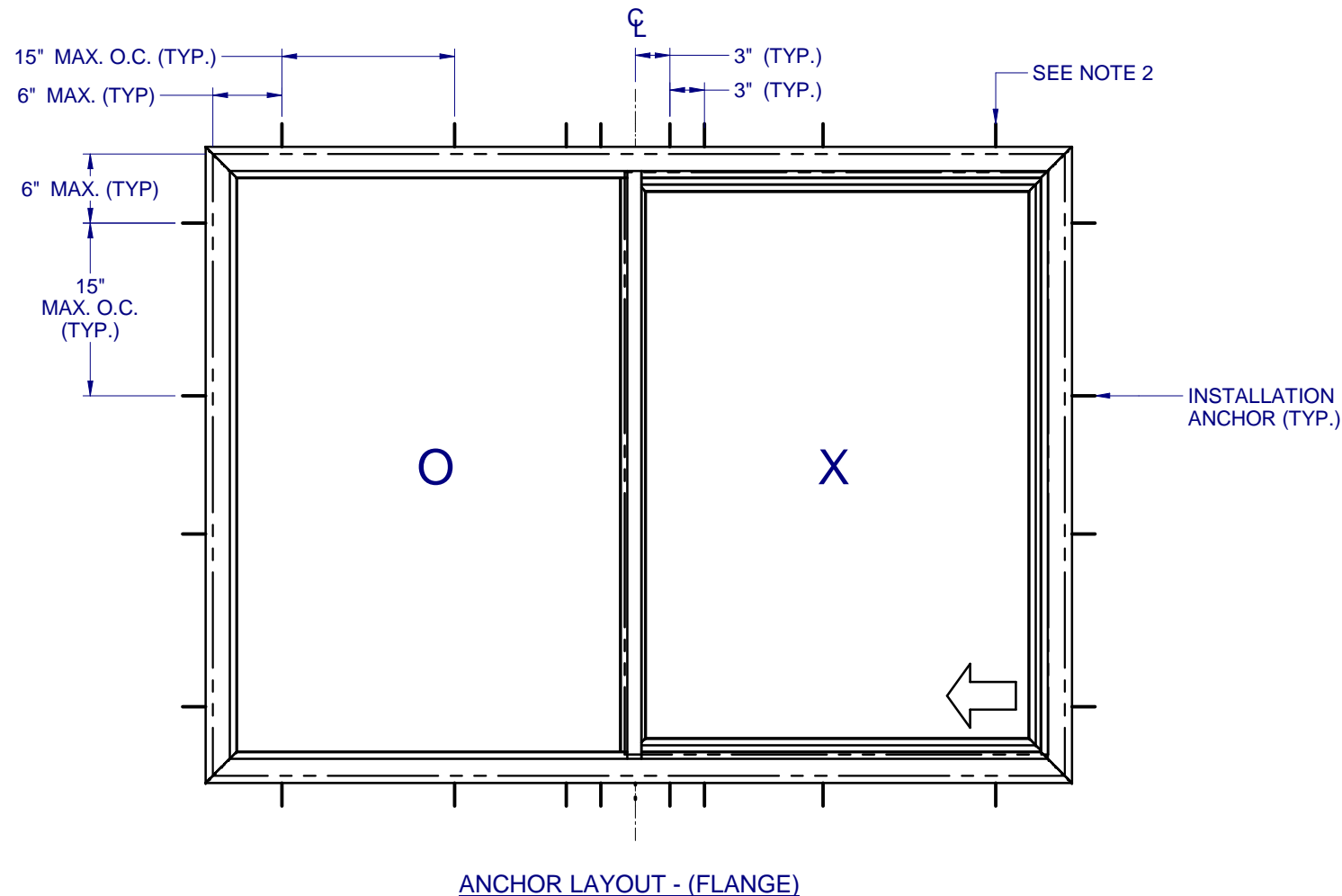

NOTES:

1. INSTALL ONE ANCHOR AT EACH INSTALLATION LOCATION. SILL ANCHOR SPACING SAME AS HEAD.
2. SHIM AS REQ AT EACH INSTALLATION ANCHOR USING LOAD BEARING SHIMS. MAX. ALLOWABLE SHIM STACK TO BE 1/4". USE SHIMS WHERE SPACE GREATER THAN 1/16" IS PRESENT. LOAD BEARING SHIMS SHALL BE CONSTRUCTED OF HIGH DENSITY PLASTIC OR BETTER. WOOD SHIMS ARE NOT ALLOWED.
3. ANCHOR TYPE, SIZE, SPACING AND EMBEDMENT SHALL BE AS SPECIFIED IN THESE DRAWINGS, SEE TABLE 1, SHEET 6.
4. ALL INSTALLATION ANCHORS MUST BE MADE OF OR PROTECTED WITH A CORROSION RESISTANT MATERIAL OR COATING. DISSIMILAR METALS OR MATERIALS IN CONTACT WITH PRESSURE TREATED WOOD MUST BE PROTECTED TO PREVENT REACTION.
5. INSTALLATION ANCHORS SHALL BE IN ACCORDANCE WITH ANCHOR MANUFACTURER'S INSTALLATION INSTRUCTIONS, AND ANCHORS SHALL NOT BE USED IN SUBSTRATES WITH STRENGTHS LESS THAN THE MINIMUM SPECIFIED IN TABLE 1, SHEET 6.
6. ANCHOR EMBEDMENT TO SUBSTRATE SHALL BE BEYOND WALL DRESSING OR STUCCO. FOR CONCRETE/CMU OPENINGS, EMBEDMENT SHALL BE BEYOND WOOD BUCKS, IF USED, INTO SUBSTRATE - 1X BUCKS ARE OPTIONAL.
7. A MINIMUM CENTER-TO-CENTER SPACING SHALL BE MAINTAINED BETWEEN ALL FASTENERS: 3" FOR MASONRY, 1" FOR WOOD AND METAL.
8. WOOD OR MASONRY OPENINGS, BUCKS AND BUCK FASTENERS SHALL BE PROPERLY DESIGNED BY THE ARCHITECT OR ENGINEER OF RECORD AND INSTALLED TO TRANSFER WIND LOADS TO THE STRUCTURE. SUBSTRATES SHALL MEET THE MINIMUM STRENGTH REQUIREMENTS AS SHOWN IN TABLE1, SHEET 6. CONCRETE AND MASONRY SUBSTRATES MAY NOT BE CRACKED.
9. SEALING AND FLASHING STRATEGIES FOR OVERALL WATER RESISTANCE OF INSTALLATION SHALL BE DONE BY OTHERS FOLLOWING THE CURRENT VERSION OF THE REFERENCE DOCUMENTS: FMA/AAMA 100(FIN WINDOWS), FMA/AAMA 200(FLANGE WINDOWS), FMA/WDMA 250(BOX WINDOWS), FMA/AAMA/WDMA 300(EXTERIOR DOORS)

**8200 PVC
 HORIZ. SLIDER
 NON-IMPACT**

PROPRIETARY AND CONFIDENTIAL
 THE INFORMATION CONTAINED IN THIS DRAWING IS THE SOLE PROPERTY OF CUSTOM WINDOW SYSTEMS, INC. ANY REPRODUCTION IN PART OR AS A WHOLE WITHOUT THE WRITTEN PERMISSION OF CUSTOM WINDOW SYSTEMS, INC IS PROHIBITED.

FLORIDA APPROVAL NO.:
 4092

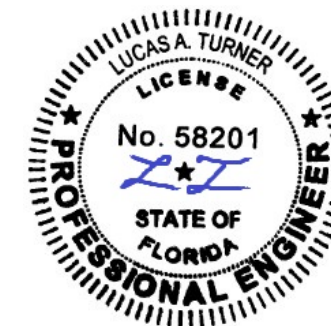

7/27/2023

LUCAS A. TURNER, P.E.
 FL PE # 58201
 Turner Engineering & Consulting, Inc.
 2428 Old Natchez Trc Trl
 Camden, TN 38320
 PH. 941-380-1574

SHEET DESCRIPTION:
ANCHOR SCHEDULE AND NOTES

DRAWN BY: ADE	DATE: 10/13/11
DWG #: CWS-486E	REV.: E
SCALE: 1:15	SHEET 5 OF 6

8200 PVC HORIZ. SLIDER NON-IMPACT

PROPRIETARY AND CONFIDENTIAL
THE INFORMATION CONTAINED IN THIS DRAWING IS THE SOLE PROPERTY OF CUSTOM WINDOW SYSTEMS, INC. ANY REPRODUCTION IN PART OR AS A WHOLE WITHOUT THE WRITTEN PERMISSION OF CUSTOM WINDOW SYSTEMS, INC IS PROHIBITED.

FLORIDA APPROVAL NO.:
4092

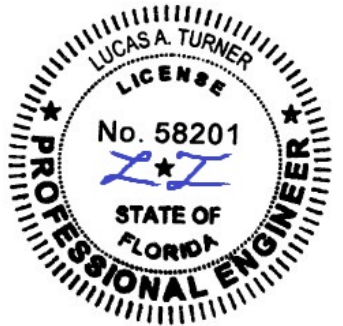

7/27/2023

LUCAS A. TURNER, P.E.
FL PE # 58201
Turner Engineering & Consulting, Inc.
2428 Old Natchez Trc Trl
Camden, TN 38320
PH. 941-380-1574

SHEET DESCRIPTION:

INSTALLATION DETAILS

DRAWN BY: ADE	DATE: 10/13/11
DWG #: CWS-486E	REV.: E
SCALE: 1:2	SHEET 6 OF 6

TYPICAL HEAD ANCHORAGE

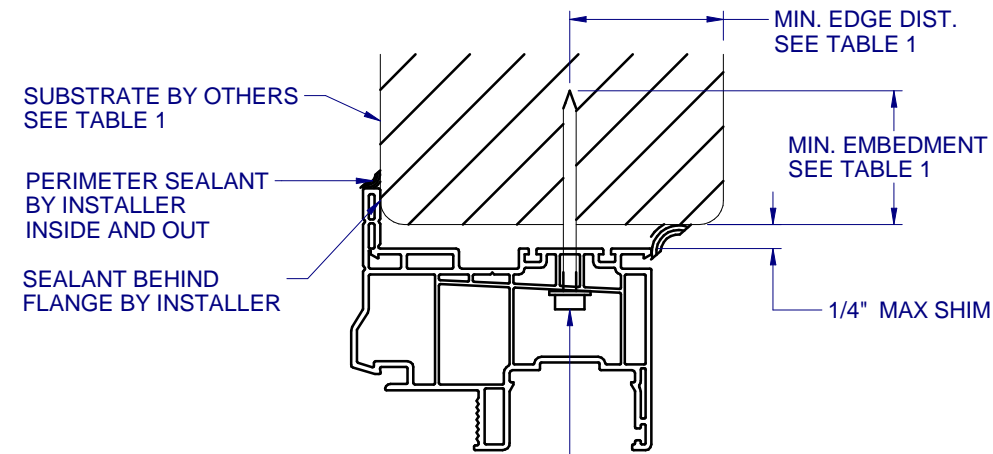

INSTALLATION ANCHOR
SEE TABLE 1

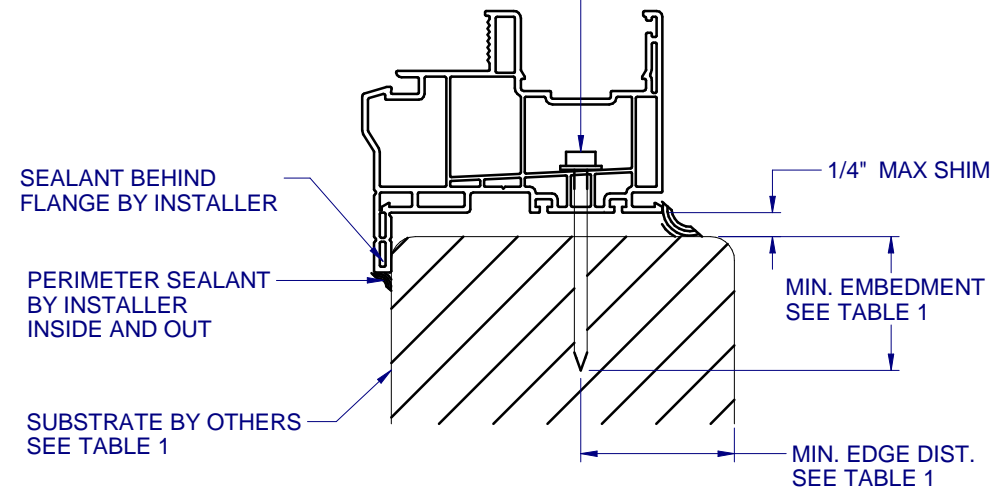

A
6 VERTICAL SECTION
TYPICAL SILL ANCHORAGE

MIN. EMBEDMENT
SEE TABLE 1

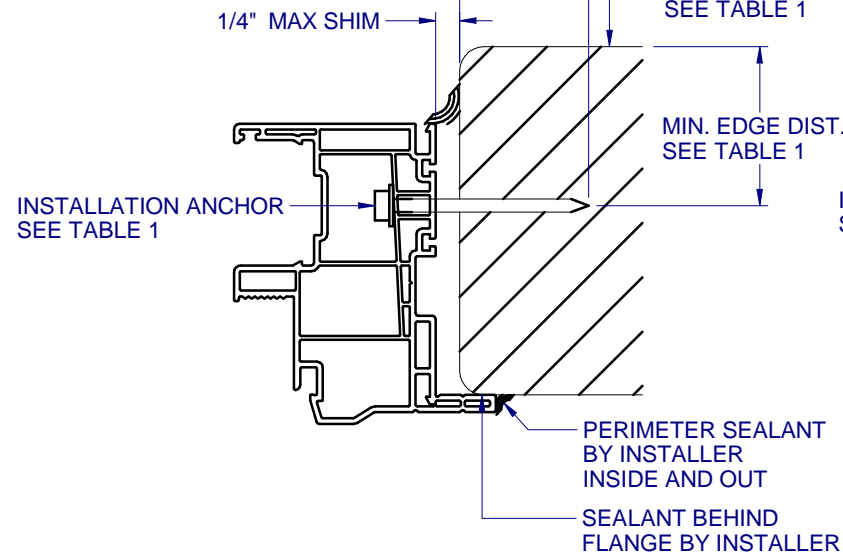

B
6 HORIZONTAL SECTION
TYPICAL JAMB ANCHORAGE

MIN. EMBEDMENT
SEE TABLE 1

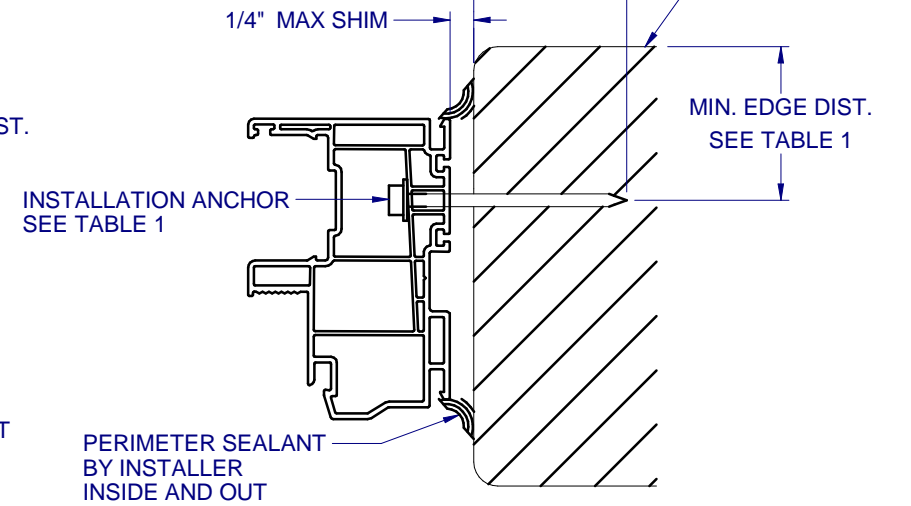

C
6 HORIZONTAL SECTION
BOX FRAME INSTALLATION
HEAD AND SILL SIMILAR FOR BOX INSTALLATION

TABLE 1: APPROVED INSTALLATION FASTENERS

SUBSTRATE TYPE	ANCHOR TYPE	MIN. EMBEDMENT	MIN. EDGE DIST.
CONCRETE (2.0 KSI MIN.)	3/16" ITW TAPCON	1"	1-1/8"
HOLLOW OR GROUT-FILLED CMU (117 PCF MIN.)	3/16" ITW TAPCON	1"	2"
CONCRETE (3.05 KSI MIN.)	3/16" DEWALT ULTRACON+	1-3/4"	1"
HOLLOW OR GROUT-FILLED CMU (ASTM C-90)	3/16" DEWALT ULTRACON+	1-1/4"	2-1/2"
2X MIN. SPRUCE-PINE-FIR (G=0.42)	3/16" ITW TAPCON OR DEWALT ULTRACON+	1-3/8"	7/8"
2X MIN. SPRUCE-PINE-FIR (G=0.42)	#10 WOOD SCREW	1-3/8"	7/8"
16 GAUGE (0.060") MIN. STEEL STUD (33 KSI YIELD MIN)	#10-16 HILTI KWIK-FLEX OR ITW TEKS SELF-DRILLING SCREW	FULL THREAD THRU 0.060"	7/16"
1/8" ALUM. (6063-T5 MIN.) OR 1/8" STEEL (33 KSI MIN.)	#10 GRADE 5 SELF-TAPPING / DRILLING SCREW	FULL THREAD THRU 0.125"	7/16"

FLANGE REMOVAL NOTE: PARTIALLY OR FULLY REMOVING THE FLANGE, UP TO AND INCLUDING A BOX-FRAME APPLICATION IS ACCEPTABLE PROVIDED:

- MIN. 1/4" FILLET OF CONSTRUCTION-GRADE ADHESIVE CAULK IS APPLIED INSIDE AND OUT, FULL PERIMETER, BY INSTALLER.
- PRODUCT ANCHORAGE IS IN ACCORDANCE WITH REQUIREMENTS AS SHOWN FOR FLANGE WINDOWS.