

GENERAL NOTES

1. THE PRODUCT SHOWN HEREIN IS DESIGNED AND MANUFACTURED TO COMPLY WITH THE REQUIREMENTS OF THE 7TH EDITION (2020) FLORIDA BUILDING CODE FOR USE OUTSIDE THE HIGH VELOCITY HURRICANE ZONE. PRODUCT WAS TESTED FOR LIMITED WATER PERFORMANCE (FULL WATER SPRAY BUT WITH ZERO WATER PRESSURE DIFFERENTIAL), AND MAY BE USED WHERE THIS LEVEL OF WATER PERFORMANCE IS ACCEPTED BY THE AHJ.
2. DOOR FRAMING IS 3/16" THICKNESS FRP, AND DOOR PANELS ARE PROPRIETARY FRP-REINFORCED FRP/STYRENE/POLYMER FOAM CONSTRUCTION.
3. THIS DOCUMENT ADDRESSES PRODUCT ANCHORAGE TO ACHIEVE THE INDICATED DESIGN PRESSURES AT THE INDICATED SIZES, IN THE CONFIGURATIONS INDICATED. INSTALL PRODUCTS WITH MAXIMUM SHIM GAP, MINIMUM EDGE DISTANCE AND EMBEDMENT, AND WITH FASTENER TYPE AS SHOWN IN THE DETAILS AND AS INDICATED IN TABLE 1. FOR FULL PRODUCT CONSTRUCTION DETAILS SEE INTERTEK TEST REPORT 104711107MID-013R1
4. THIS PRODUCT AS SHOWN IN THIS DRAWING IS WIND ZONE 4 MISSILE LEVEL D LARGE MISSILE IMPACT RESISTANT, AND DOES NOT REQUIRE THE USE OF IMPACT PROTECTIVE DEVICES (SHUTTERS) IN WINDBORNE DEBRIS REGIONS.
5. THE 4/3 ALLOWABLE STRESS INCREASE FACTOR (SHORT-TERM INCREASE FACTOR) HAS NOT BEEN USED IN THE ANCHOR ANALYSIS FOR THIS SYSTEM. THE 1.6 Cd FACTOR WAS USED IN THE ANALYSIS OF ANCHORAGE INTO WOOD SUBSTRATE.
6. THE OPENING SUBSTRATE MATERIALS (FRAMING, MASONRY, BUCKS) AND ATTACHMENT OF BUCKS TO THE SUBSTRATE ARE BY OTHERS AND SHALL BE VERIFIED BY THE ARCHITECT OR ENGINEER OF RECORD OR AS APPROVED BY THE AUTHORITY HAVING JURISDICTION (AHJ). BUCKING, OPENINGS, & BUCKING FASTENERS MUST BE PROPERLY DESIGNED & INSTALLED BY OTHERS IN ACCORDANCE WITH THE FBC TO TRANSFER SUPERIMPOSED LOADS TO THE STRUCTURE. WITH MASONRY OPENINGS, WOOD BUCKS ARE OPTIONAL.
7. DISSIMILAR MATERIALS THAT COME INTO CONTACT SHALL BE COATED OR OTHERWISE PROTECTED TO PREVENT GALVANIC REACTIONS. WOOD BUCKS, IF USED, SHALL BE PRESSURE TREATED, WITH EITHER A TREATMENT OR COATING COMPATIBLE WITH THIS PRODUCT.
8. ANCHORAGE NOTES: ALL ANCHORS USED SHALL BE OF A MATERIAL OR HAVE A COATING COMPATIBLE WITH PRESSURE TREATED WOOD BUCKS AND ALL OTHER WINDOW MATERIALS. INSTALL ONE ANCHOR AT EACH LOCATION SHOWN IN THE ANCHOR ELEVATION. ENSURE 4" MIN. SPACING IS MAINTAINED BETWEEN ANY TWO INSTALLATION FASTENERS. INSTALL SHIMS AT EACH ANCHOR LOCATION WHERE A GAP OF 1/16" OR GREATER EXISTS BETWEEN PRODUCT FRAME AND SUBSTRATE. SHIMS SHALL BE LOAD-BEARING (PLASTIC OR METALLIC) AND CAPABLE OF TRANSFERRING LOADS TO SUBSTRATE. SPECIFIED ANCHOR EMBEDMENT TO SUBSTRATE SHALL BE BEYOND WALL FINISH OR STUCCO.
9. WOOD BUCKS LESS THAN 1-1/2" THICK ARE OPTIONAL AND MAY BE USED WITH CONCRETE/CMU, WITH ANCHOR EMBEDMENT BEYOND WOOD BUCKS AND INTO MASONRY.
10. ALL FASTENERS SHALL BE IN ACCORDANCE WITH THESE DRAWINGS, OR AS APPROVED, SIGNED, AND SEALED BY A FLORIDA-REGISTERED PROFESSIONAL ENGINEER. ALTERNATE HARDWARE SUCH AS LOCK/LATCH DEVICES, BOLTS, HINGES, OR CONTINUOUS HINGES MAY BE USED, PROVIDED THAT THEY DO NOT REQUIRE ANY MODIFICATIONS TO THE APPROVED DOOR AS INDICATED IN THIS APPROVAL, AND THAT ANY SUCH HARDWARE IS APPROVED, SIGNED, AND SEALED BY A FLORIDA-REGISTERED PROFESSIONAL ENGINEER, OR HAS SEPARATE PRODUCT APPROVAL WITH LISTING FOR USE ON AN FRP DOOR, RATED FOR IMPACT AND AT LEAST THE SIZES AND DESIGN PRESSURES INDICATED IN THIS DOOR APPROVAL. NON-STRUCTURAL OPTIONS SUCH AS VIEWERS (PEEPHOLES) AND DOOR CLOSERS BY OTHERS ARE DEEMED TO BE MINOR MODIFICATIONS TO THE PRODUCT AND ARE ALLOWED. SCREW-APPLIED OPTIONS SUCH AS CLOSERS ARE RECOMMENDED BY THE MANUFACTURER TO BE THROUGH-BOLTED WITH WASHERS/NUTS AS INDICATED IN THIS APPROVAL FOR THE SURFACE BOLTS.
11. SEALING AND FLASHING STRATEGIES FOR OVERALL WATER INFILTRATION RESISTANCE OF THE INSTALLED PRODUCT SHALL BE THE RESPONSIBILITY OF OTHERS AND ARE NOT ADDRESSED BY THIS DOCUMENT.

EDGEWATER EH DOOR, LARGE MISSILE IMPACT

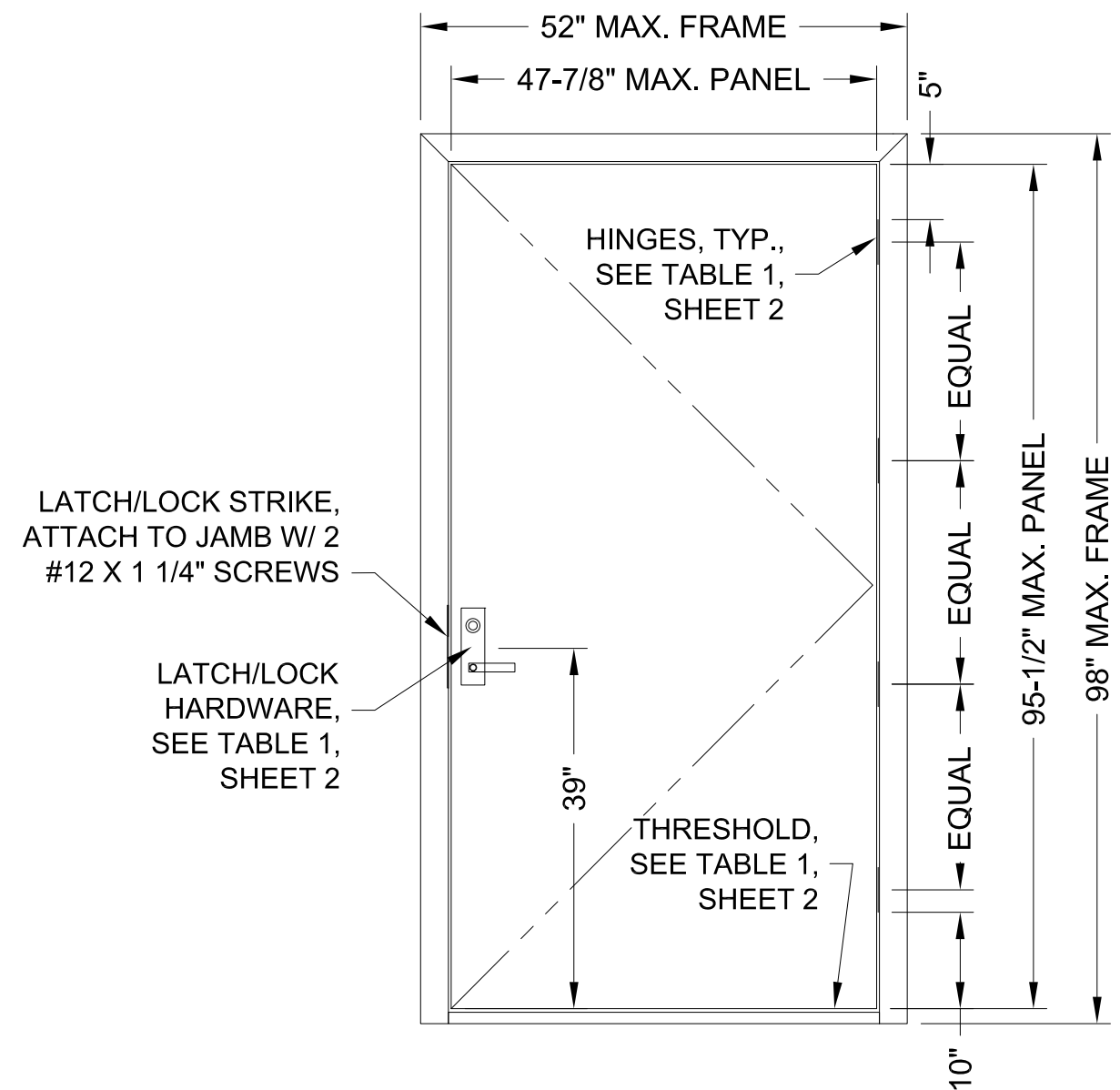

OUTSWING SINGLE ELEVATION

DESIGN PRESSURE TABLE

CONFIGURATION	MAX. PANEL SIZE	DESIGN PRESSURE RATING
SINGLE OR PAIR	47-7/8" X 95-1/2"	+/-70 PSF



Neenah, WI
Ph. 920-886-1998
www.edgewaterfrp.com

SHEET DESCRIPTION: NOTES, SINGLE DOOR ELEVATION	DATE DRAWN: 3/29/2022
SCALE: NTS	REV: 0
DRAWING: EH-DOOR-FPA	SHEET: 1 OF 6



4/27/2022
Lucas A. Turner, P.E.
FL PE #58201
2428 Old Natchez Trc Trl
Camden, TN 38320
Ph. 941-380-1574

TABLE 1 - APPROVED HARDWARE	
HARDWARE TYPE	APPROVED OPTIONS
LATCH/LOCK SETS (3/4" LATCHBOLT PROJECTION, 1" DEADBOLT PROJECTION)	HAGER 3800 SERIES SARGENT 8200 SERIES SCHLAGE L9400 SERIES
HINGES (4.5"x4.5"x0.134" 5-KNUCKLE, FULL MORTISE)	IVES FBB1 HAGER BB1279 MCKINNEY TA2714 STANLEY FBB179
SURFACE BOLTS (1/4"x3/4"x12" FLAT BAR, 1" MIN. THROW)	IVES 453 HAGER 276D ROCKWOOD 580
THRESHOLDS (5" WIDE, 1/2" HIGH, BUMPER TYPE)	ZERO 567 HAGER 477S OR 520S PEMKO 2001T OR 2005T

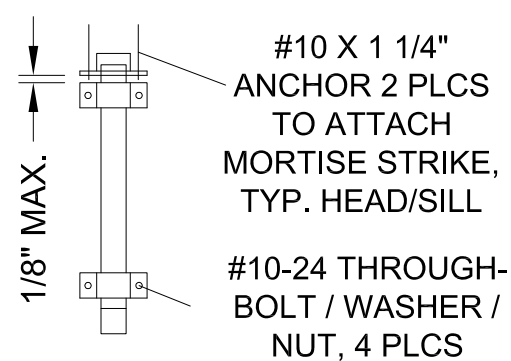

TYP. SURFACE BOLT ANCHORAGE

(INTERIOR TOP AND BOTTOM OF BOTH PANELS IN DOOR PAIRS)

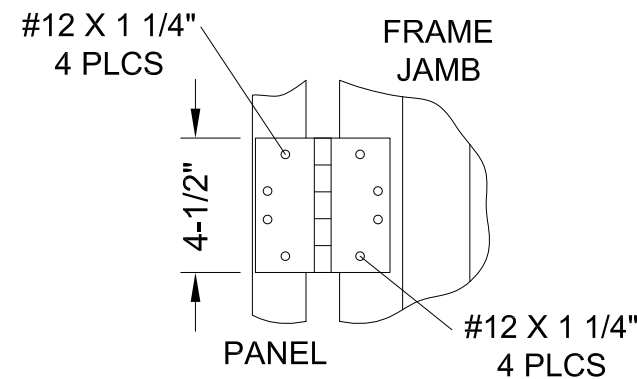

TYP. HINGE ANCHORAGE

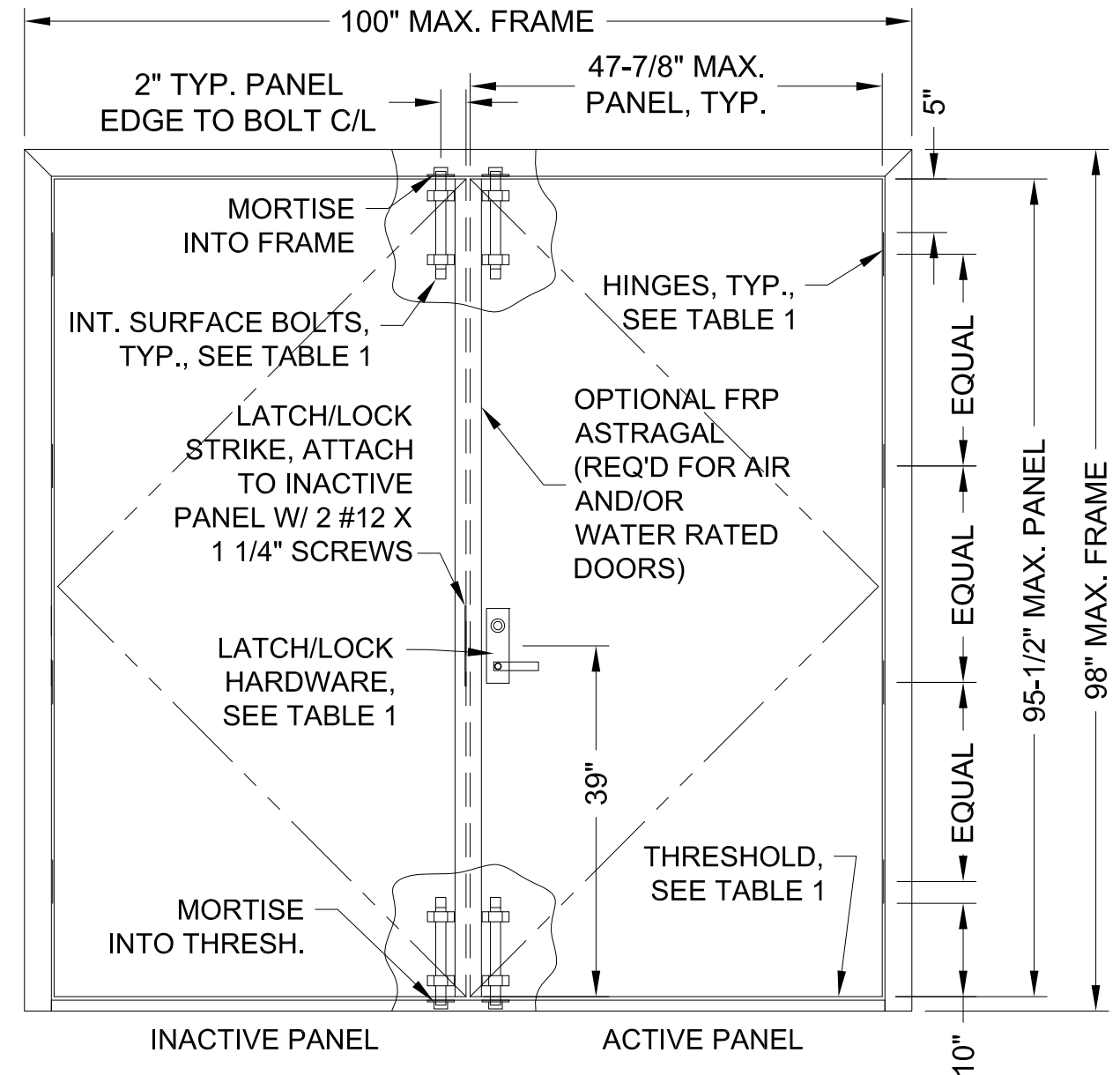

OUTSWING PAIR ELEVATION

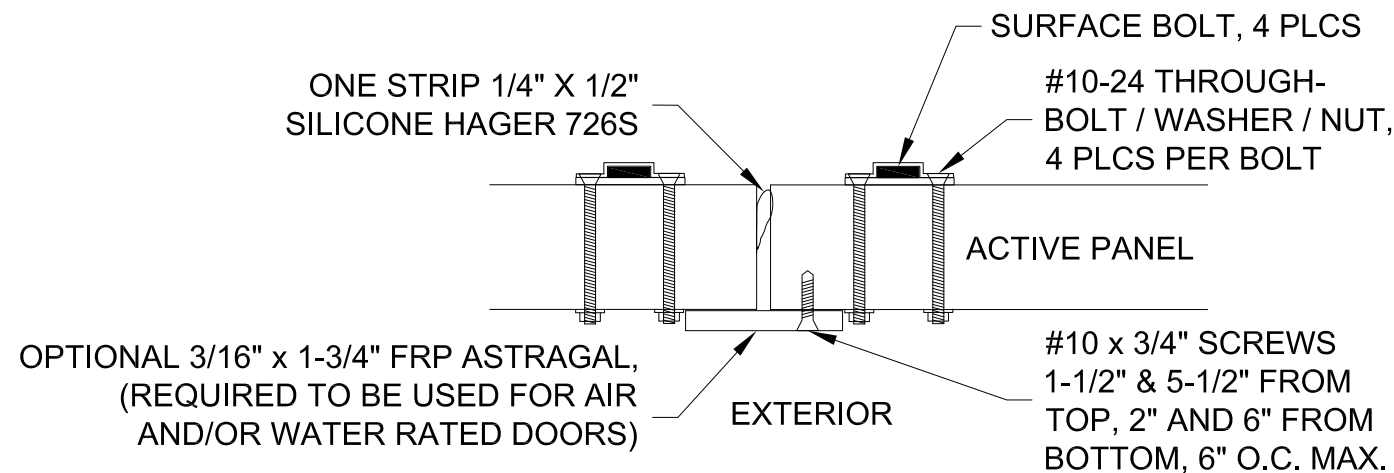

DOOR PAIR MEETING STILES DETAIL



Neenah, WI
Ph. 920-886-1998
www.edgewaterfrp.com

SHEET DESCRIPTION:
HARDWARE, PAIR ELEVATION

SCALE: NTS

DRAWING: EH-DOOR-FPA

DATE DRAWN:
3/29/2022

REV: 0

SHEET: 2 OF 6

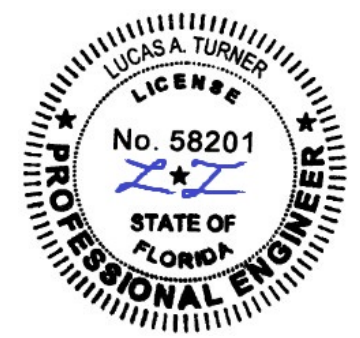

4/27/2022
Lucas A. Turner, P.E.
FL PE #58201
2428 Old Natchez Trc Trl
Camden, TN 38320
Ph. 941-380-1574

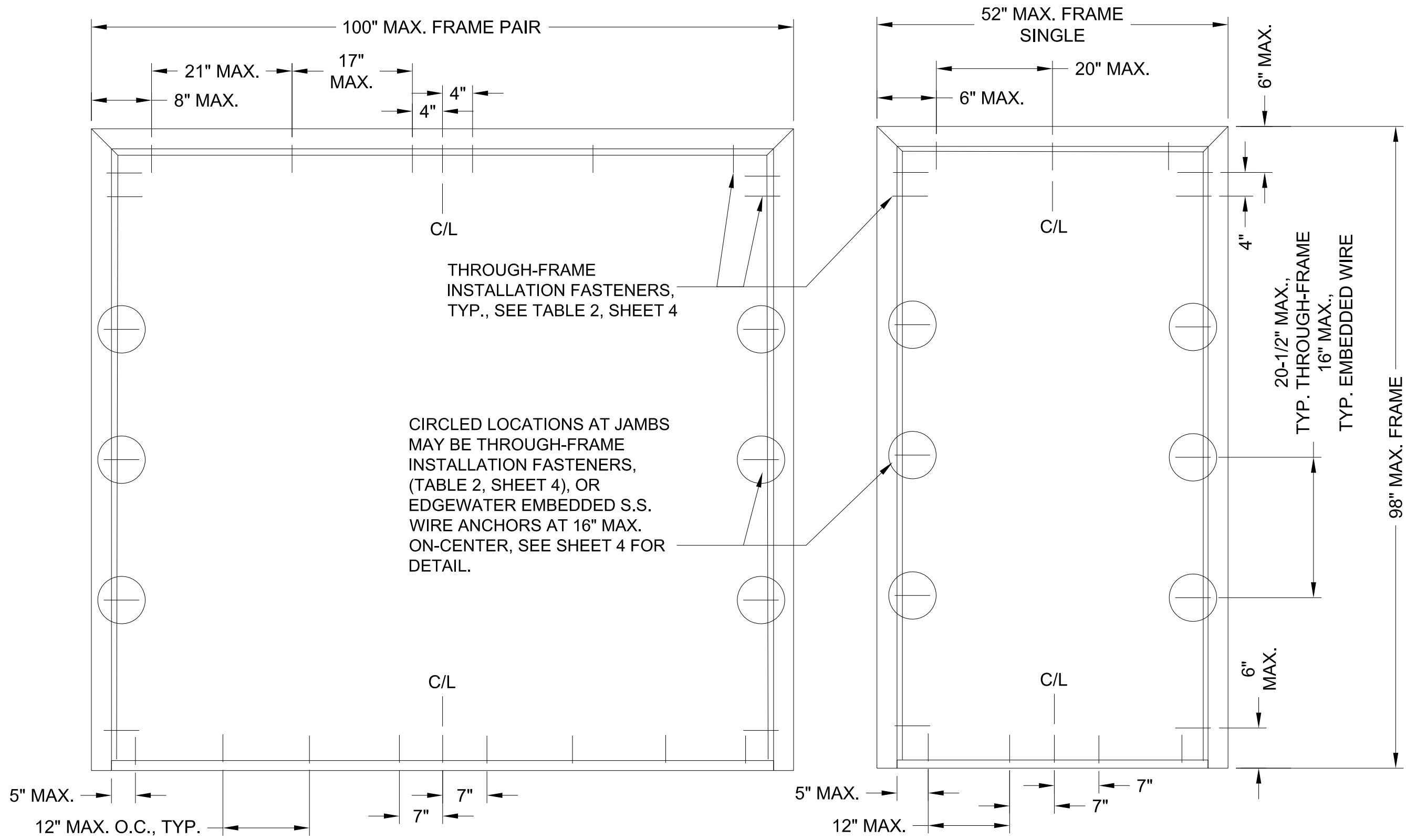

TYPICAL ANCHOR SPACING ELEVATIONS

ALL JAMB
DIMENSIONS
TYPICAL SINGLE
DOOR OR PAIR

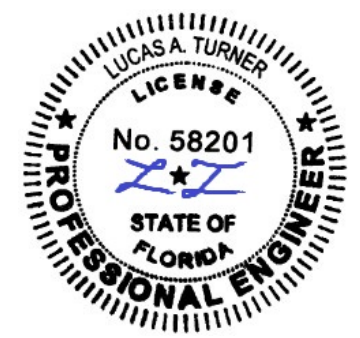

		Neenah, WI Ph. 920-886-1998 www.edgewaterfrp.com	
SHEET DESCRIPTION: ANCHOR SPACING ELEVATIONS		DATE DRAWN: 3/29/2022	
SCALE: NTS		REV: 0	
DRAWING: EH-DOOR-FPA		SHEET: 3 OF 6	

4/27/2022
 Lucas A. Turner, P.E.
 FL PE #58201
 2428 Old Natchez Trc Trl
 Camden, TN 38320
 Ph. 941-380-1574

TABLE 2 - ALLOWABLE ANCHOR SCHEDULE

FASTENER TYPE	DESCRIPTION	BASE MATERIAL	EMBEDMENT (MIN.)	EDGE DISTANCE (MIN.)
A	#14 FLAT HEAD S.S. WOOD SCREW	WOOD (G=.42 MIN.)	1-3/4"	1"
B	1/4-20 FLAT HEAD DRILLFLEX S.S. SHEET METAL SCREW	STEEL Fy=33KSI MIN., 16GA. MIN.	FULL THRU WALL, MIN. 3 THREADS BEYOND	1/2"
C1	1/4" FLAT HEAD DEWALT ULTRACON+ COATED STEEL CONCRETE SCREW	3.05 KSI MIN. CONCRETE OR ASTM C90 CMU	1-1/4"	2-1/2"
C2	1/4" FLAT HEAD ITW TAPCON COATED STEEL CONCRETE SCREW	2 KSI MIN. SOLID CONCRETE	1-3/4"	1-1/2"

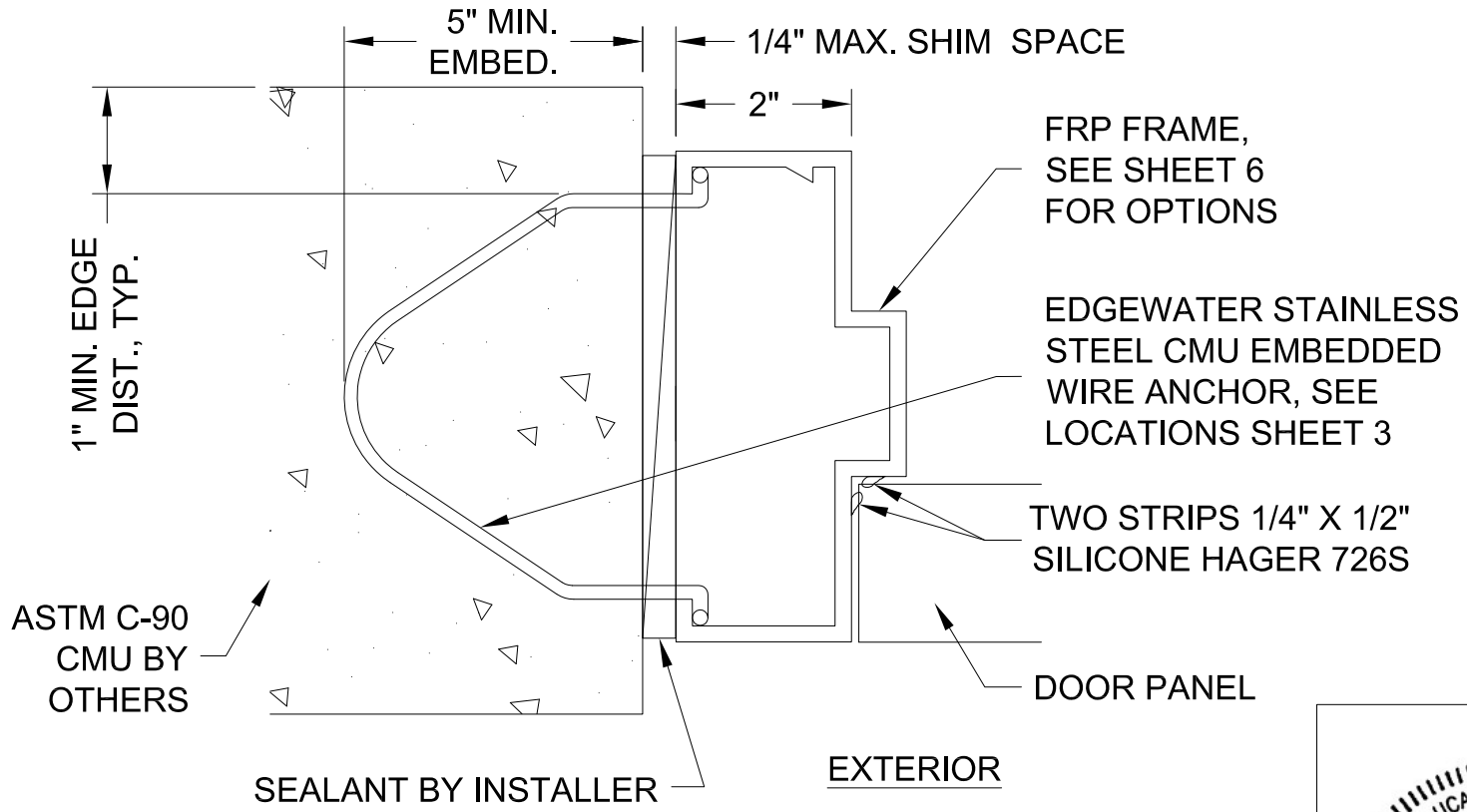
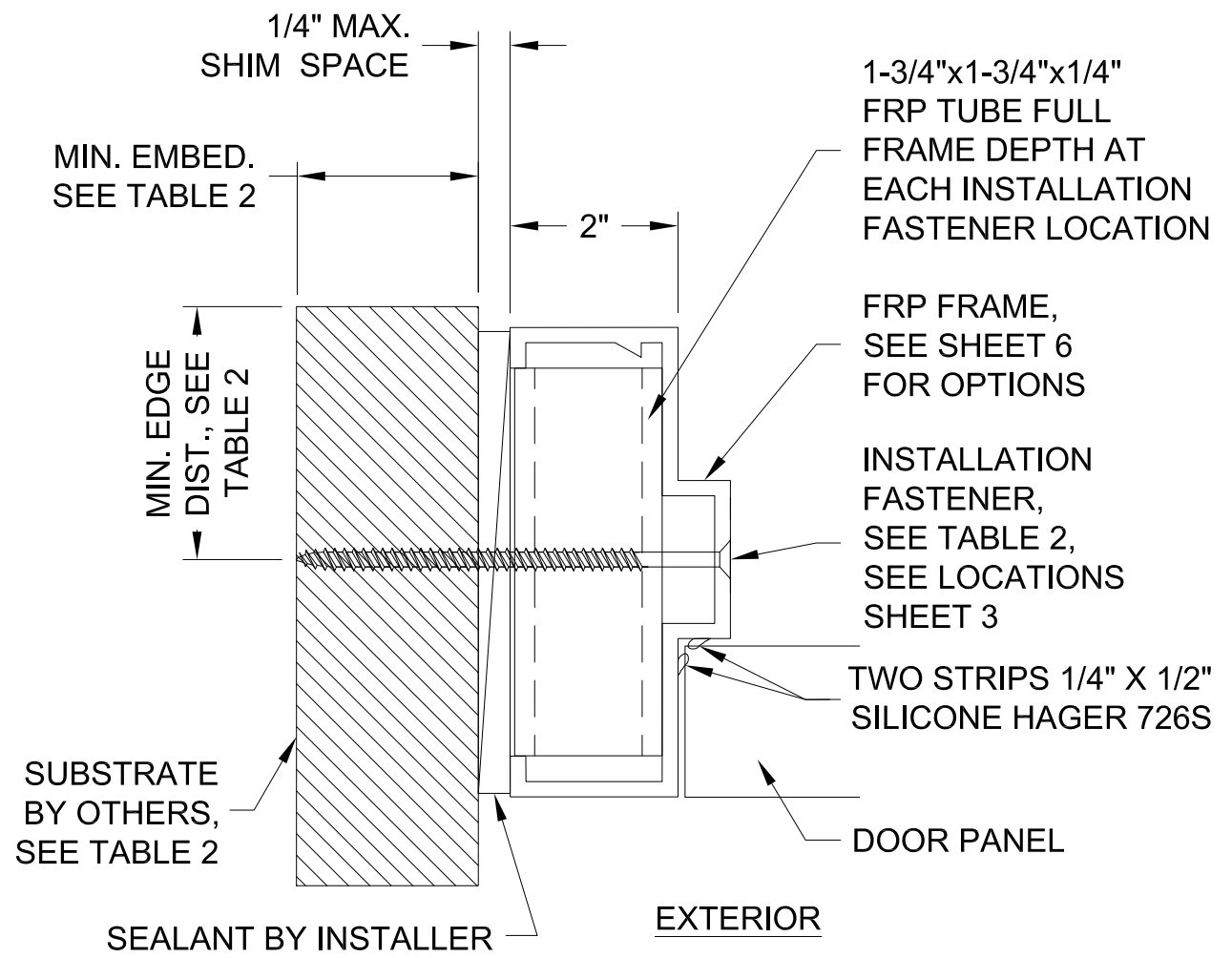
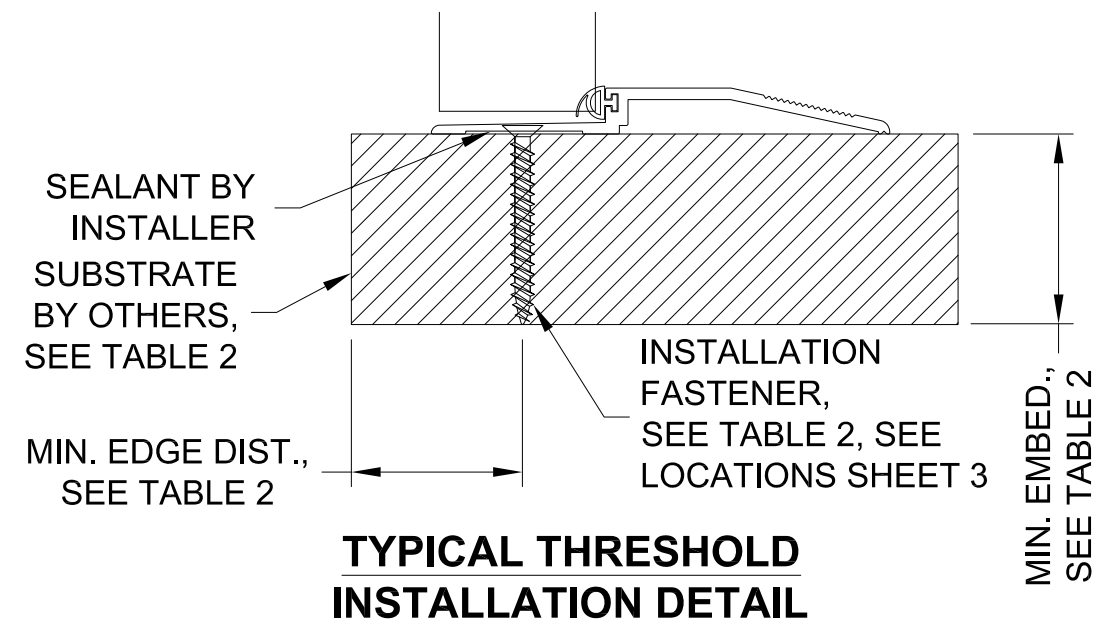

EDGEWATER DOOR
 Neenah, WI
 Ph. 920-886-1998
 www.edgewaterfrp.com

SHEET DESCRIPTION: ANCHOR TABLE, INSTALL. DETAILS	DATE DRAWN: 3/29/2022
SCALE: NTS	REV: 0
DRAWING: EH-DOOR-FPA	SHEET: 4 OF 6

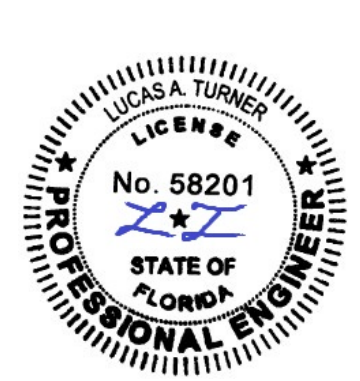

4/27/2022
 Lucas A. Turner, P.E.
 FL PE #58201
 2428 Old Natchez Trc Trl
 Camden, TN 38320
 Ph. 941-380-1574

**FIXED
FRAMES**

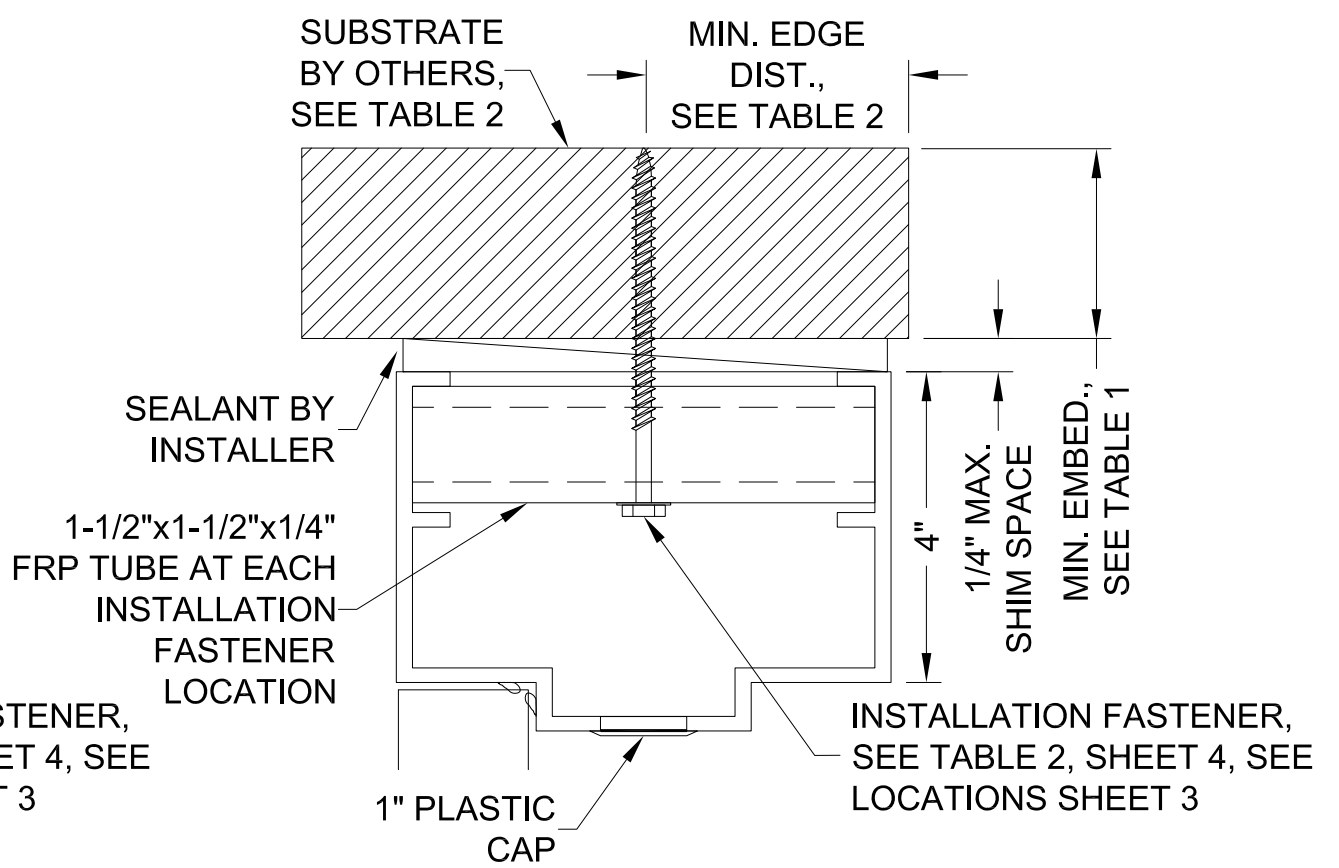
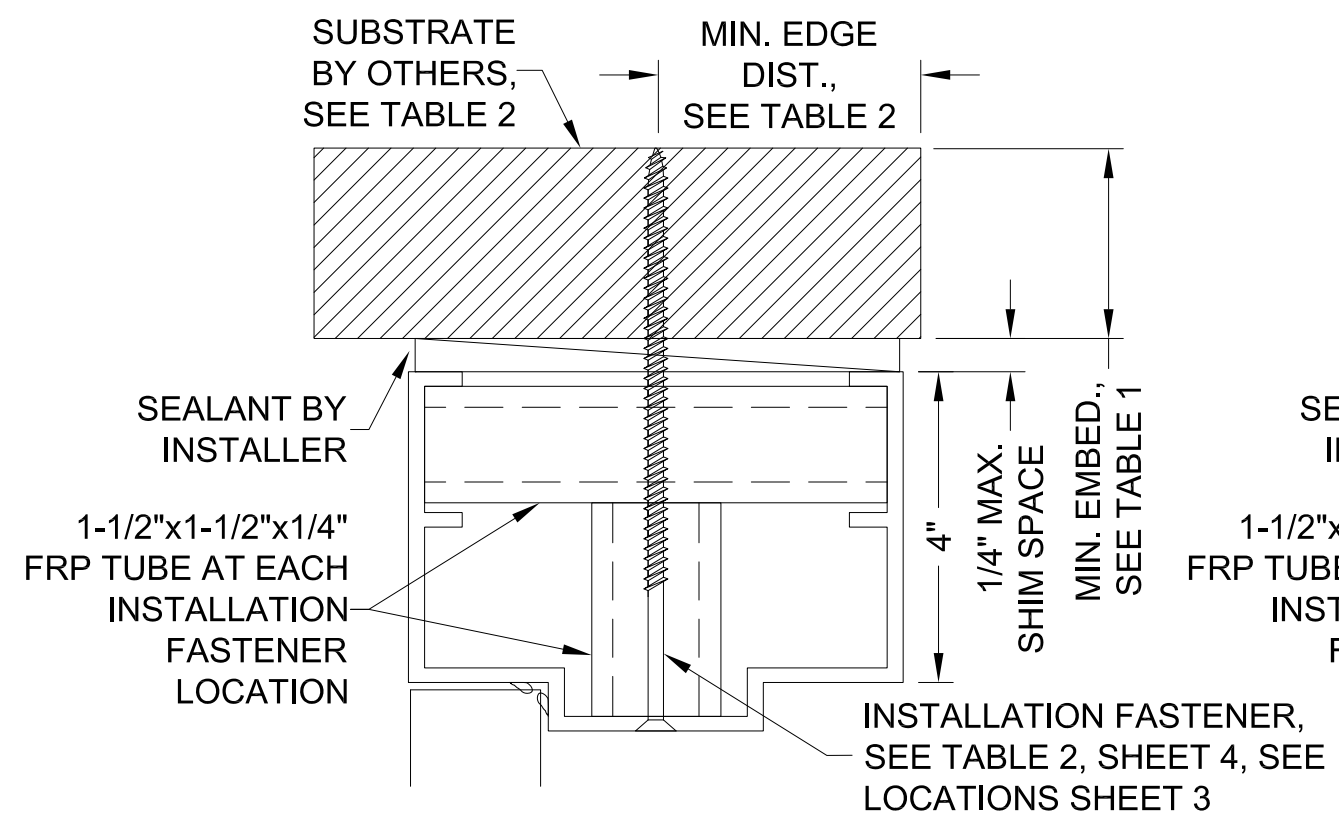

NOTE: ALL COMPONENT PARTS ARE CHEMICALLY WELDED TOGETHER BY EDGEWATER.

**ADJUSTABLE
FRAMES**

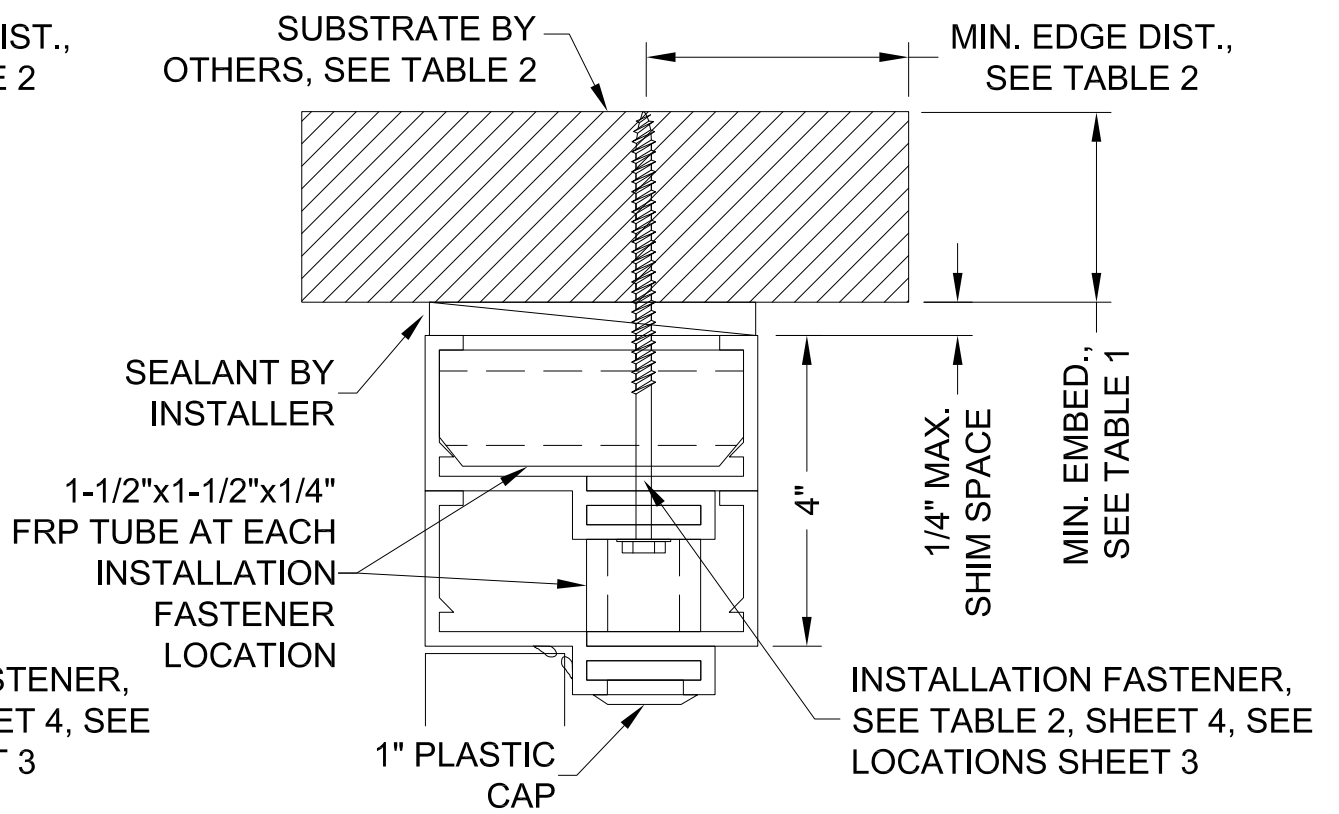
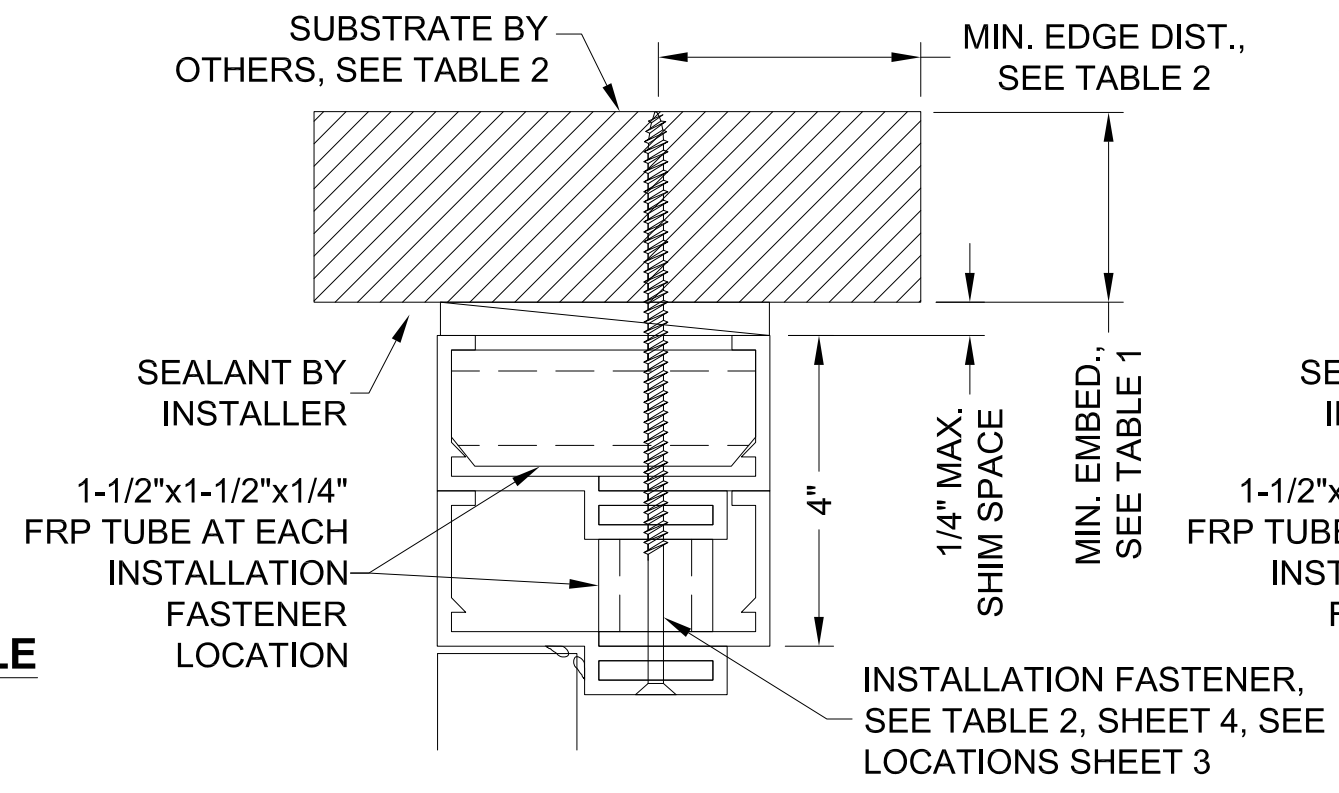

OPTIONAL 4" HEAD INSTALLATION DETAILS

		Neenah, WI Ph. 920-886-1998 www.edgewaterfrp.com	
SHEET DESCRIPTION: 4" HEAD INSTALL. DETAILS		DATE DRAWN: 3/29/2022	
SCALE: NTS		REV: 0	
DRAWING: EH-DOOR-FPA		SHEET: 5 OF 6	

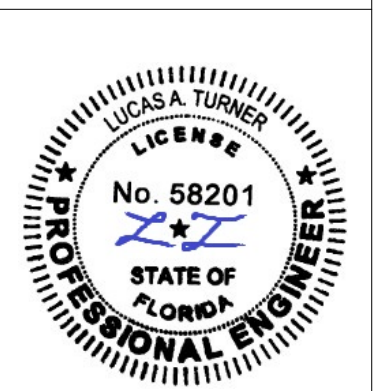

4/27/2022
 Lucas A. Turner, P.E.
 FL PE #58201
 2428 Old Natchez Trc Trl
 Camden, TN 38320
 Ph. 941-380-1574

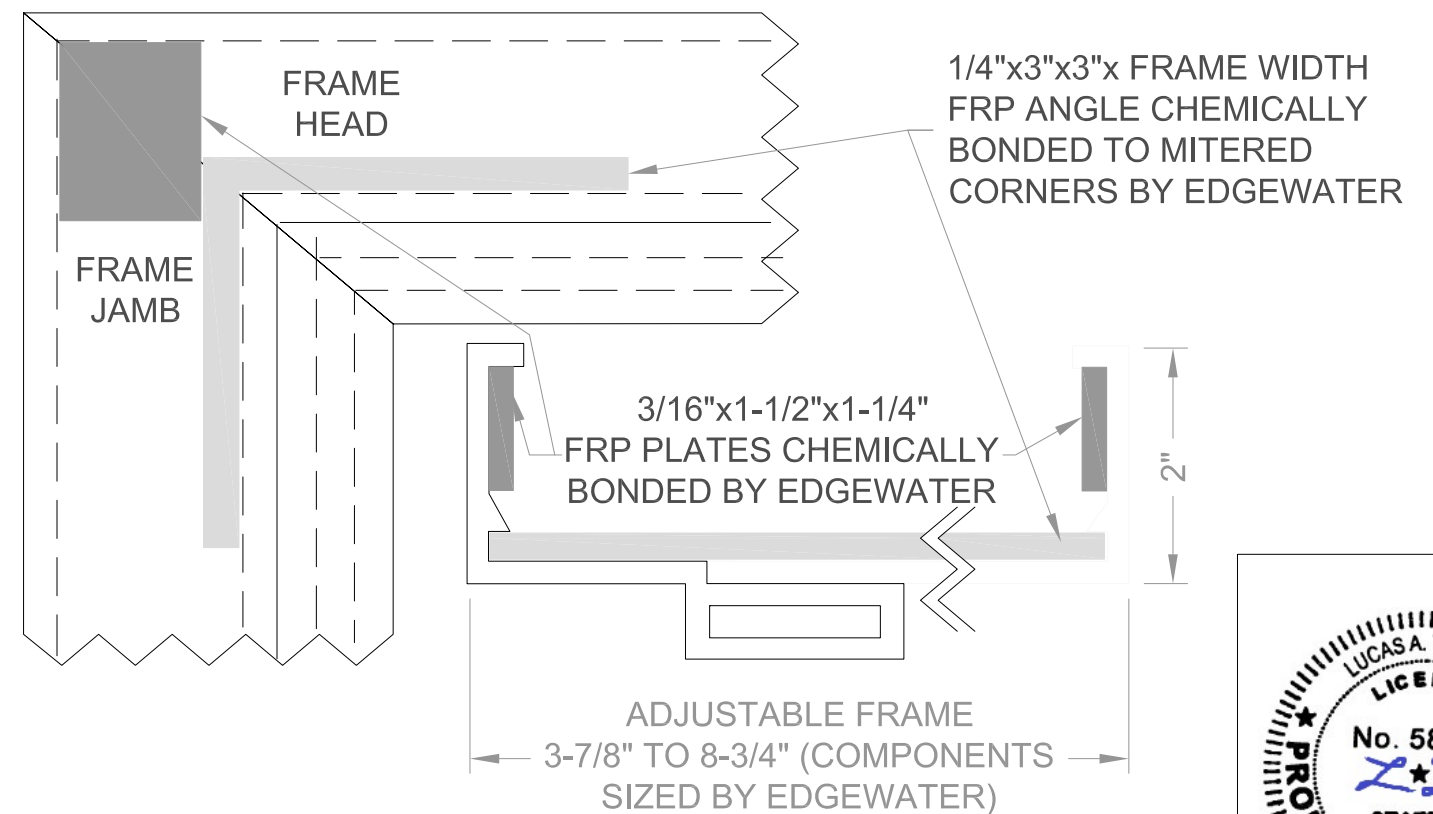
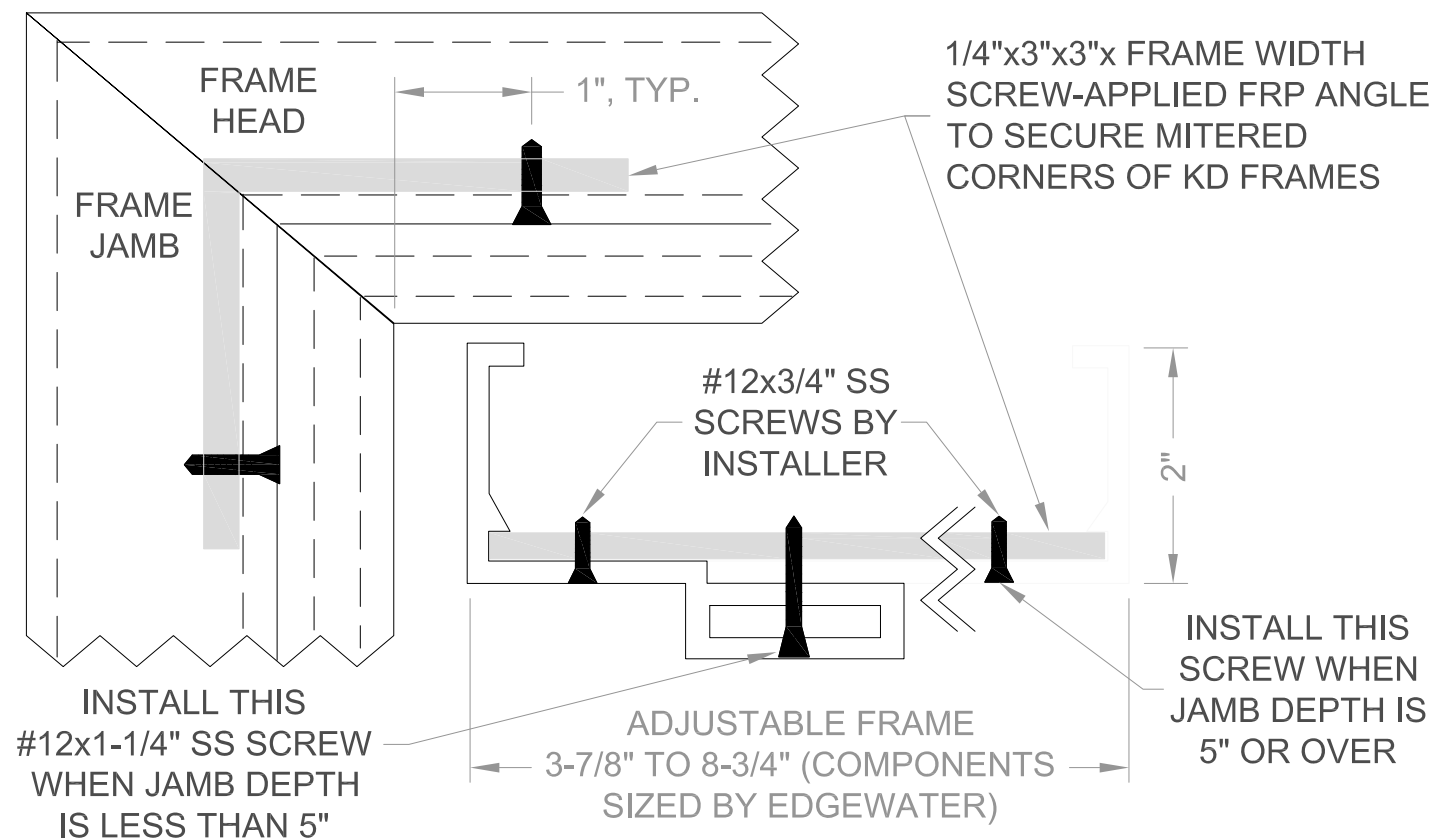
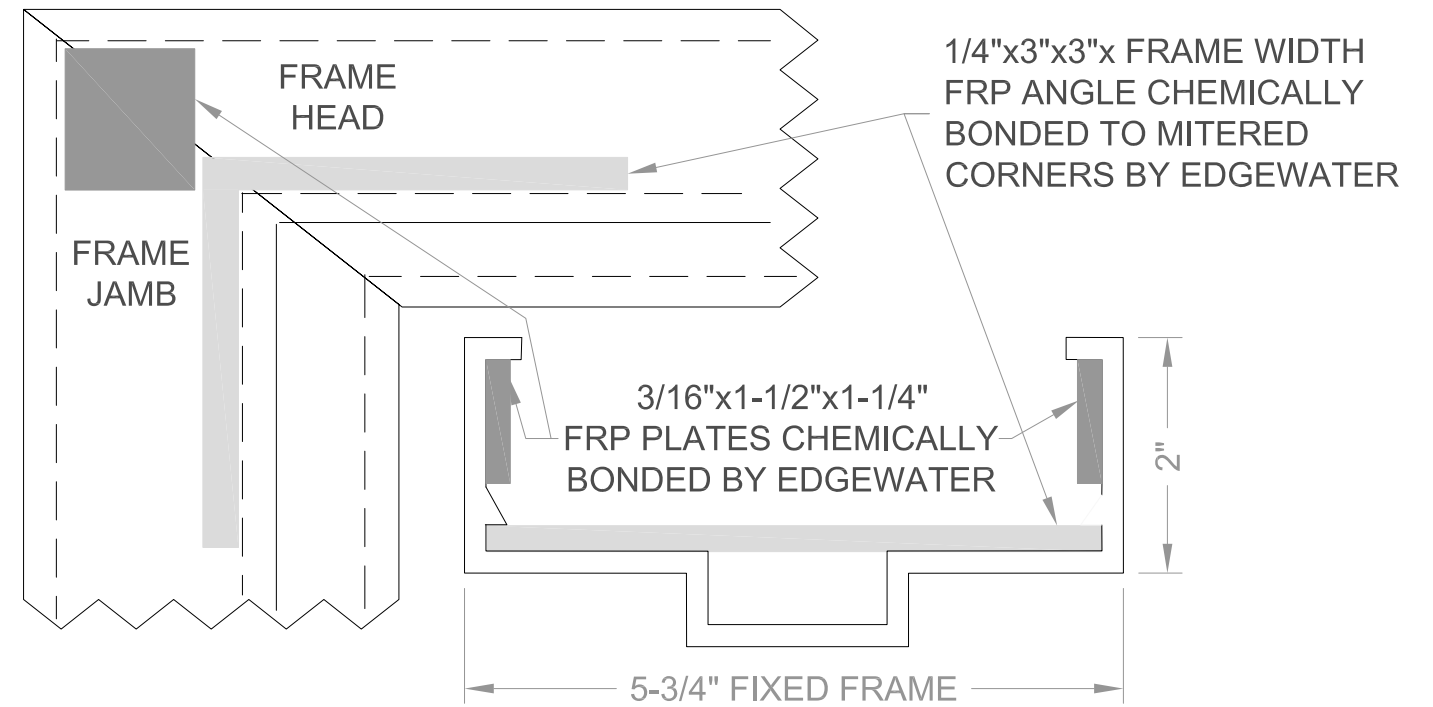
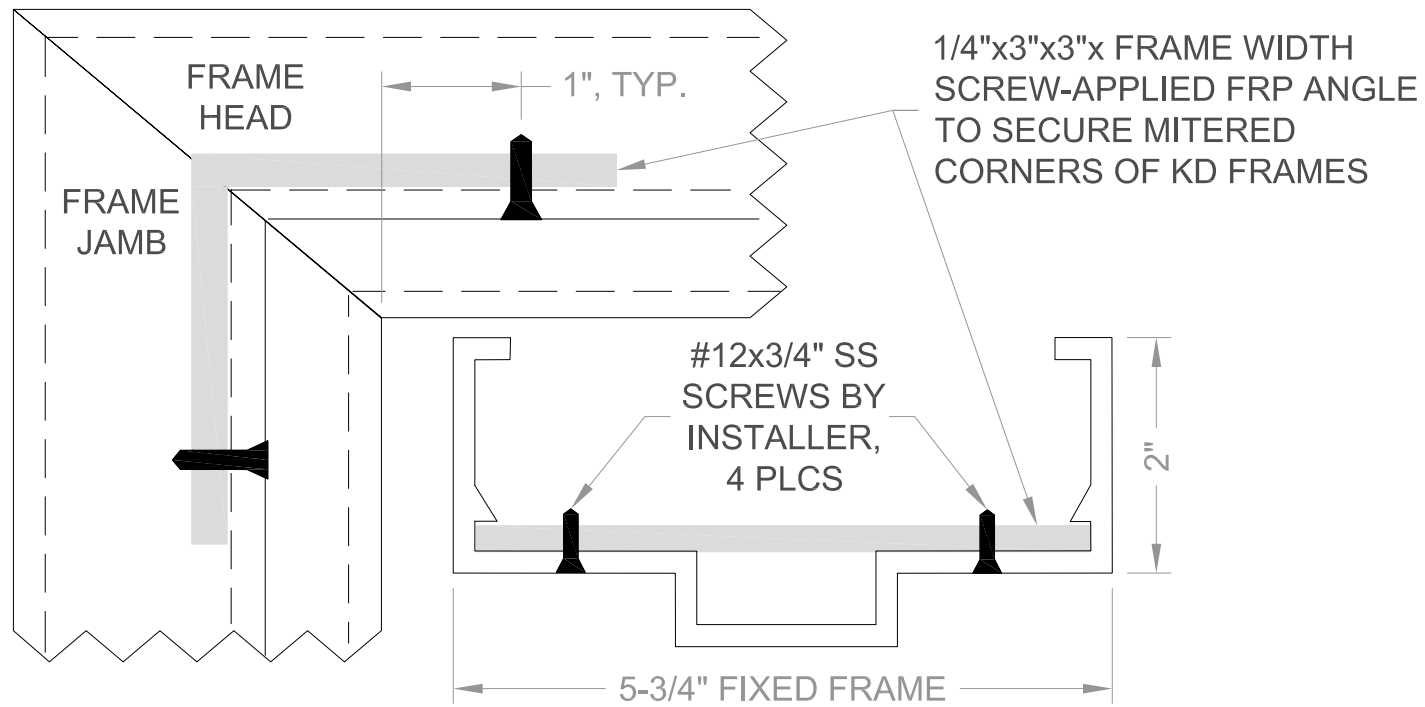

2" FRAME OPTIONS AND CORNER JOINERY DETAILS



Neenah, WI
Ph. 920-886-1998
www.edgewaterfrp.com

SHEET DESCRIPTION:
2" FRAME OPTIONS / JOINERY

DATE DRAWN:
3/29/2022

SCALE: NTS

REV: 0

DRAWING: EH-DOOR-FPA

SHEET: 6 OF 6



4/27/2022
Lucas A. Turner, P.E.
FL PE #58201
2428 Old Natchez Trc Trl
Camden, TN 38320
Ph. 941-380-1574