

Interior Skin
.015 Thick G-40 galvanized steel with an epoxy primer and baked on polyester finish which is roll-formed with a texture embossed skin.

Exterior Skin
.015 Thick G-40 galvanized steel with an epoxy primer and baked on polyester finish which is roll-formed with a texture embossed skin.

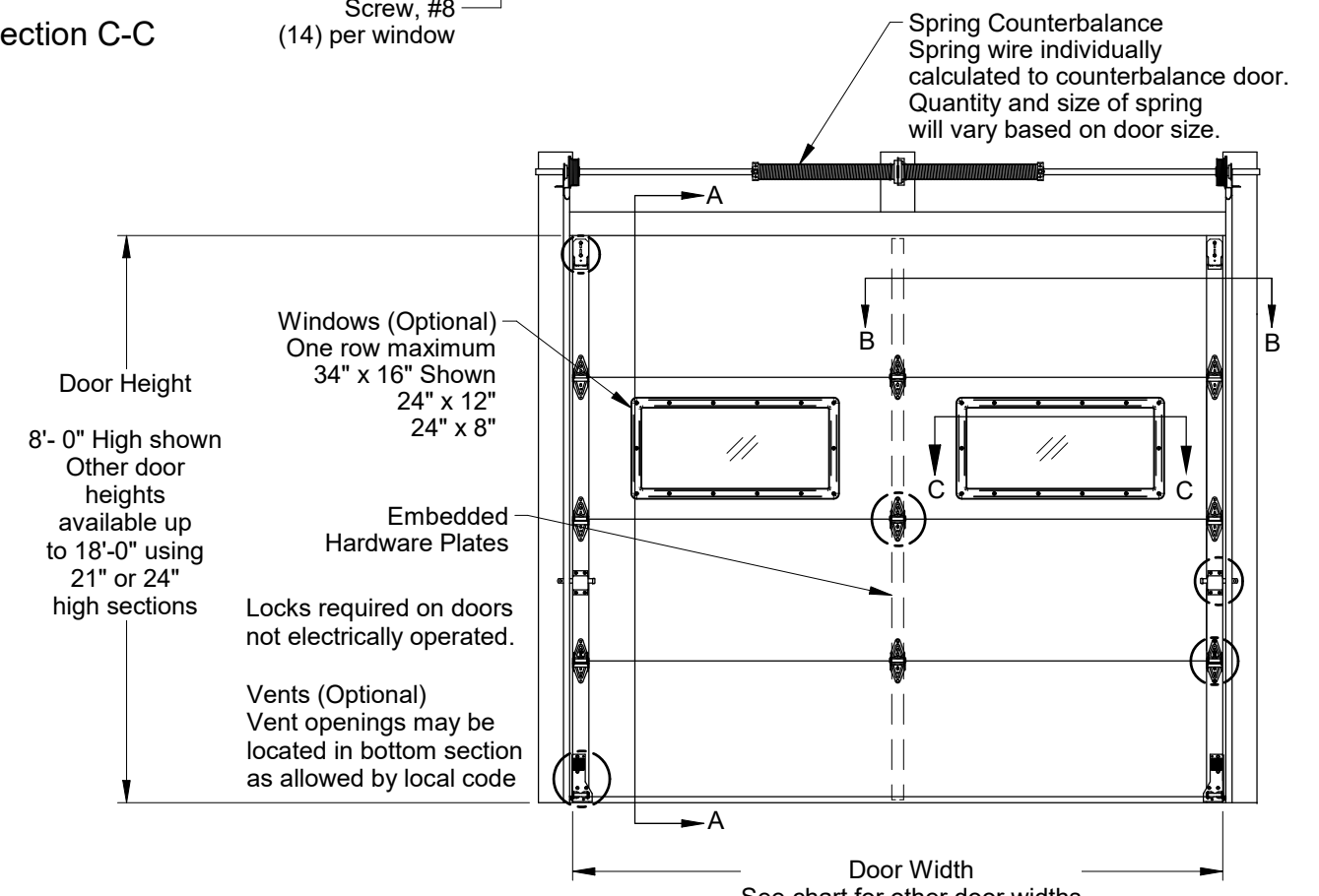
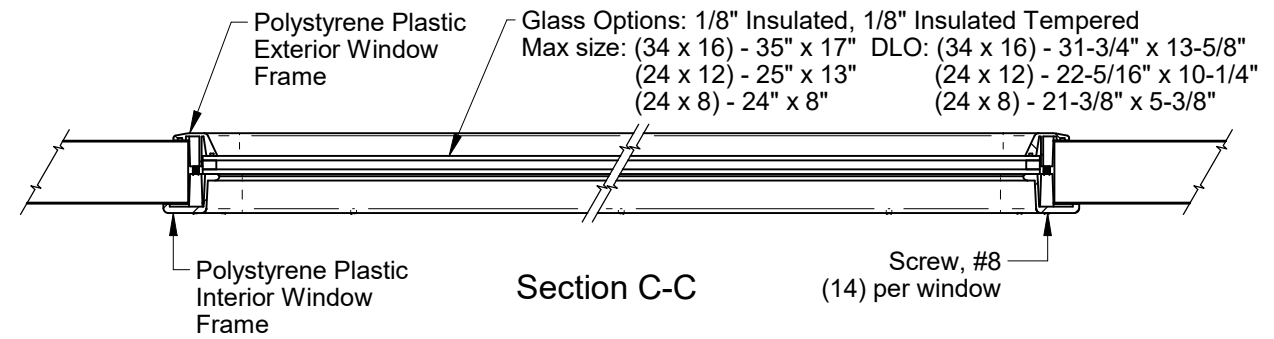
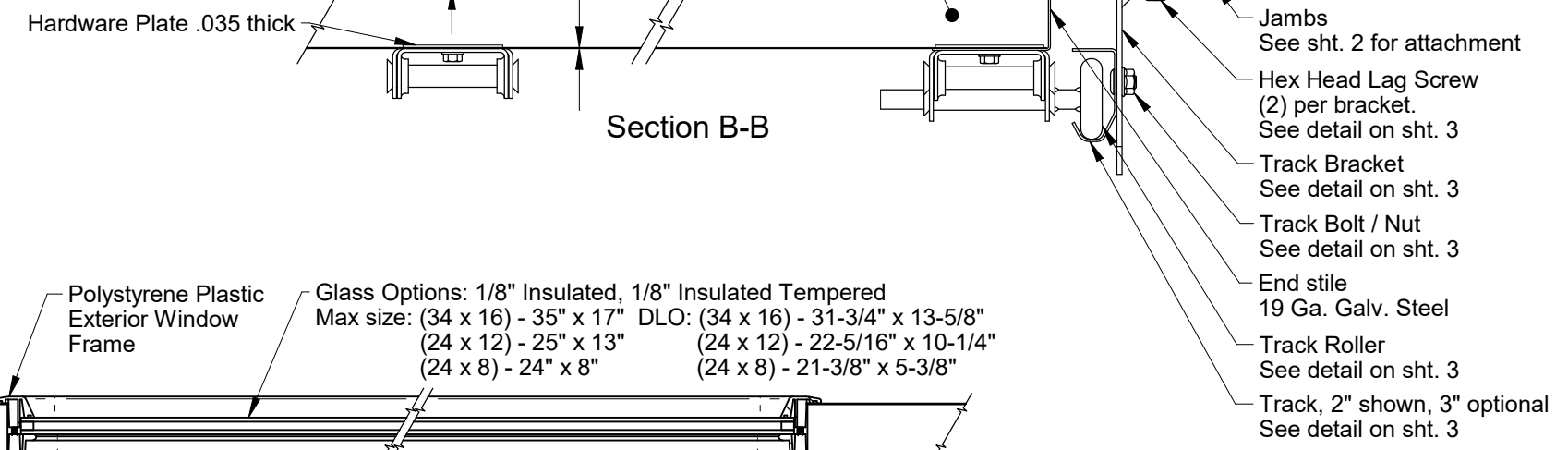

Scott A. Brown, P.E. Lic. No. 65940
Wendler Engineering Services, Inc.
698 Timber Creek Road, Dixon, IL 61021
FBPE CA Lic. No. 31544
Structural Adequacy for Wind Load

Doors tested per ANSI/DASMA 108 for static air pressure

EC224 / EC200			
Maximum Door Width	Ctr. Hngs. per Sect.	Design Loads	
Up to 8'-2"	1	12.2	-13.7
9'-2"		10.8	-12.2

Rev.	Description	ECO	Date
A	New release for production.	8593.03	10/04/22

Scale: None
Drawn by: R. Frey
Checked by: G. Wedekind
Date: 10/04/22
ECO: 8593.03



Title: Spec, Wind Load EnergyCore	
No. P-2443	Rev A
Sheet 1 of 4	

Jamb Attachment Notes:

1. Maximum Positive Load per Jamb = $(9'-2" \times 10.8 \text{ PSF}) / 2 = 50 \text{ lbs. per foot.}$
2. Maximum Negative Load per Jamb = $(9'-2" \times -12.2 \text{ PSF}) / 2 = 56 \text{ lbs. per foot.}$
3. Design of the supporting structure shall be the sole responsibility of the building designer and shall be designed for the jamb loads listed in notes 1 and 2.
4. Alternate jamb attachments may be used if approved by a registered Professional Engineer.
5. DASMA Technical Data Sheet TDS-161 may be used for alternate jamb attachments.
6. 3/8" diameter lag screws required 1/4" pilot hole and 1-1/2" minimum required distance.
7. Masonry fasteners by others.

2x6 Attachment to Structure						
Structure Type	Fastener Type	Minimum Embedment	Minimum Edge Distance	Minimum on Center Spacing	Maximum on Center Spacing	Allowable Tension Load
2500 PSI Min. Concrete	1/4" Tapcon+ (Plus) with 1-1/8" OD Washer	2"	2.5	6"	24"	526
Southern Pine	3/8" x 3" Lag with 1-1/8" OD Washer	1.50"	1.50"	1.50"	24"	655
Spruce Pine Fir	3/8" x 3" LAG with 1-1/8" OD Washer	1.50"	1.50"	1.50"	24"	482

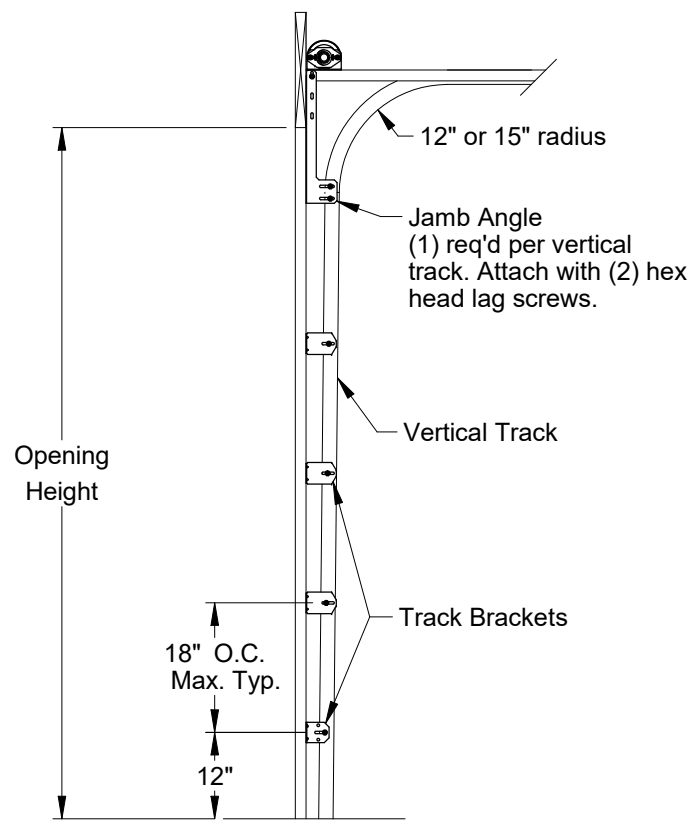
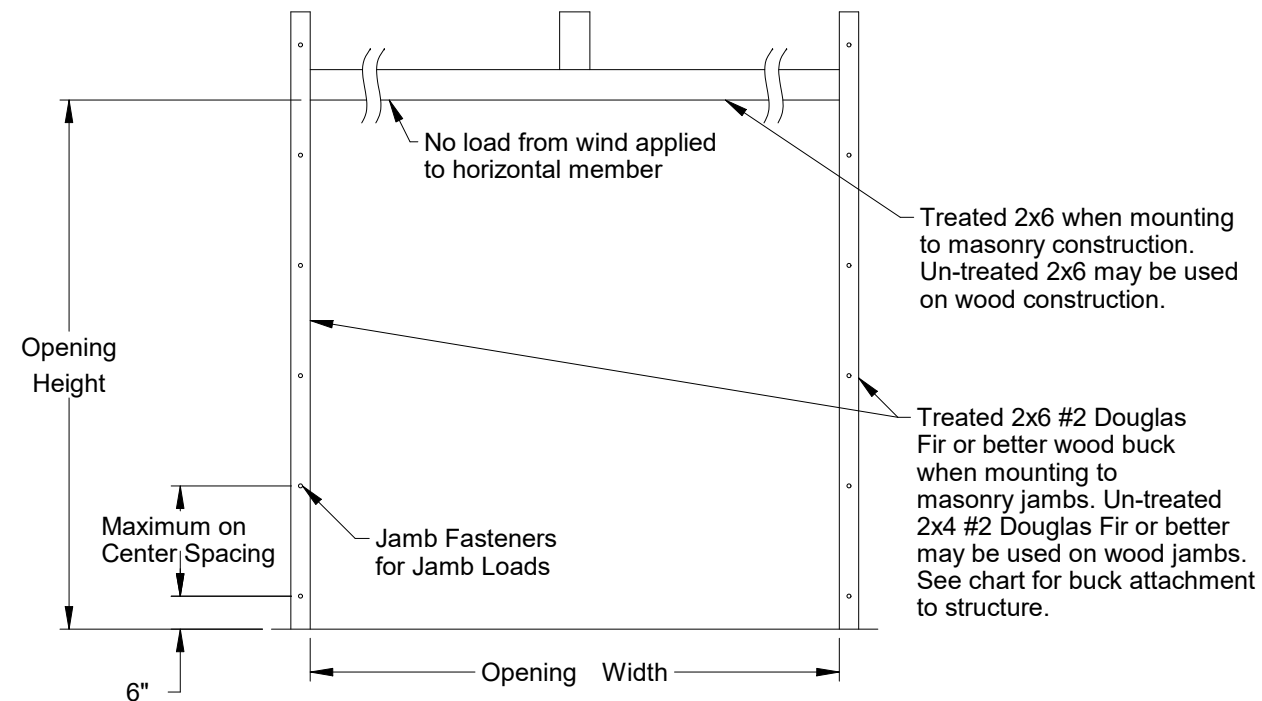

**Typical Track Installation
Bracket Mount
Wood Jamba**

Normal headroom track shown, low headroom, lift clearance and vertical lift track available.

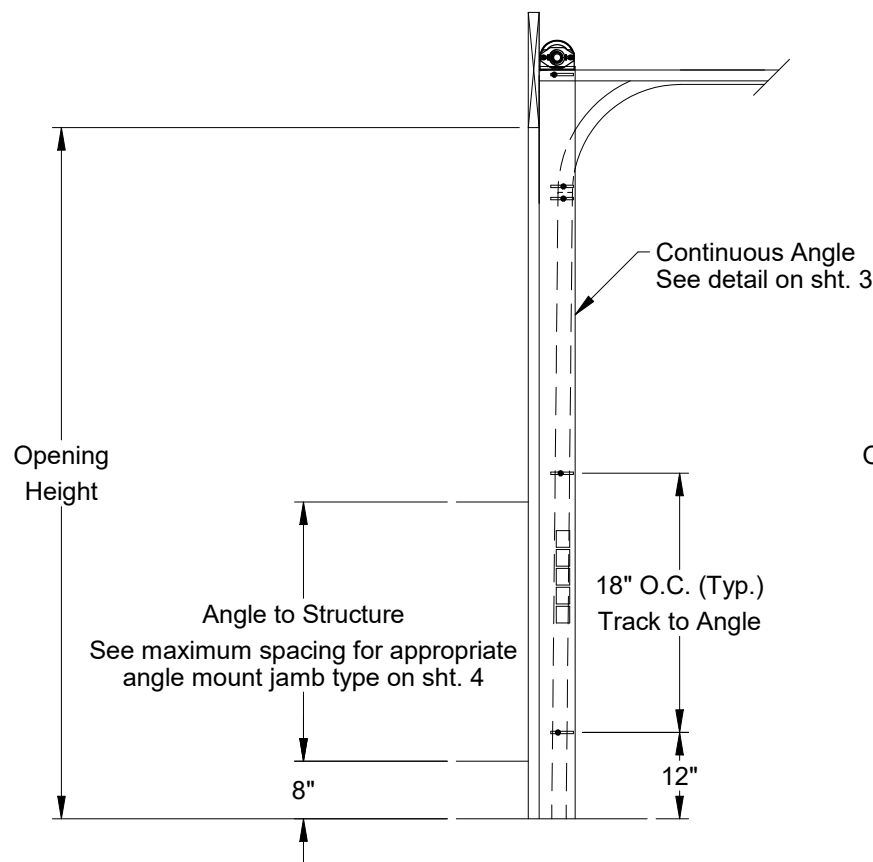

**Typical Track Installation
Angle Mount
Wood, Steel or Concrete Jamba**

Normal headroom track shown, low headroom, lift clearance and vertical lift track available.

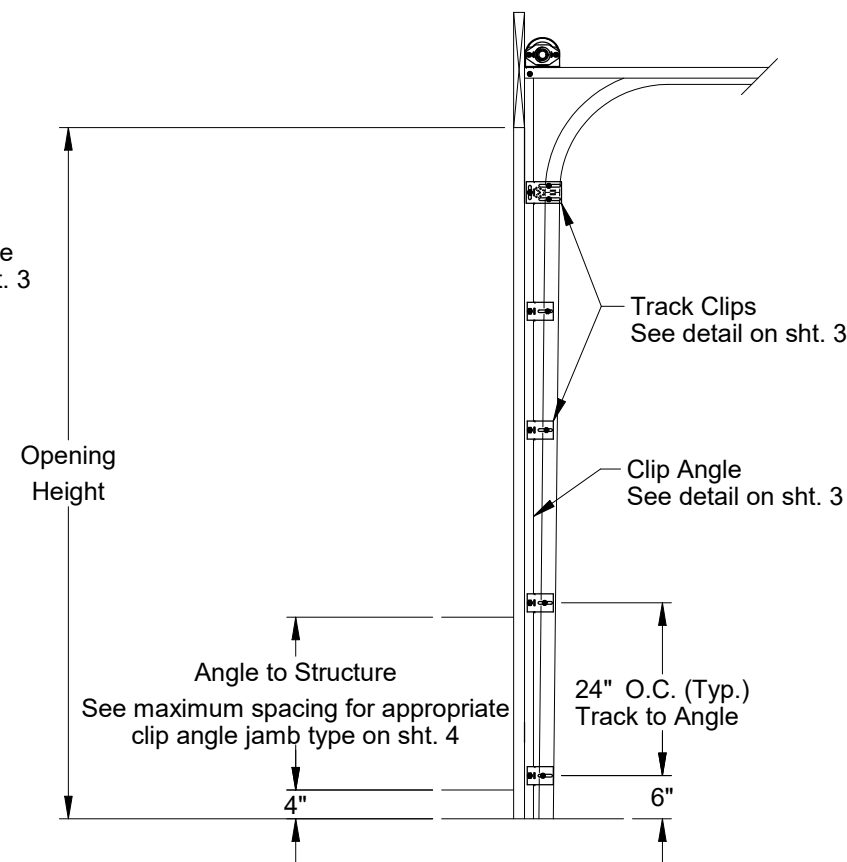

**Typical Track Installation
Pre-Assembled Clip Angle
Wood, Steel or Concrete Jamba**

Normal headroom track shown, lift clearance and vertical lift track available.



Scott A. Brown, P.E. Lic. No. 65940
Wendler Engineering Services, Inc.
698 Timber Creek Road, Dixon, IL 61021
FBPE CA Lic. No. 31544
Structural Adequacy for Wind Load

Scale: None	 1101 East River Road Dixon, IL. 61021	Title: Spec, Wind Load EnergyCore	
Drawn by: R. Frey		No. P-2443	Sheet 2
Checked by: G. Wedekind			
Date: 10/04/22			
ECO: 8593.03			

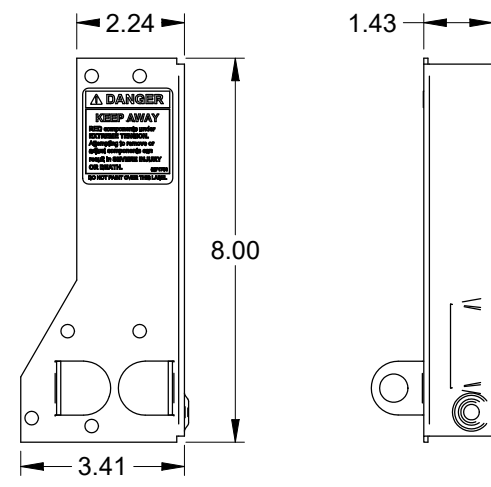

Corner Bracket
.086 Galv. Steel

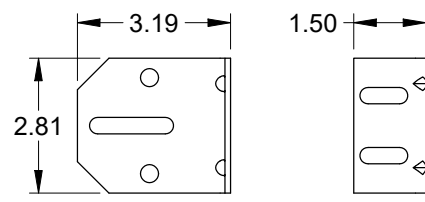

3" Track Bracket
.116 Galv. Steel

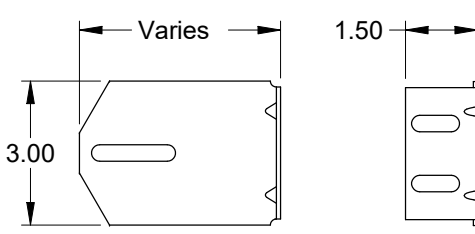

Track Bracket
.116 Galv. Steel

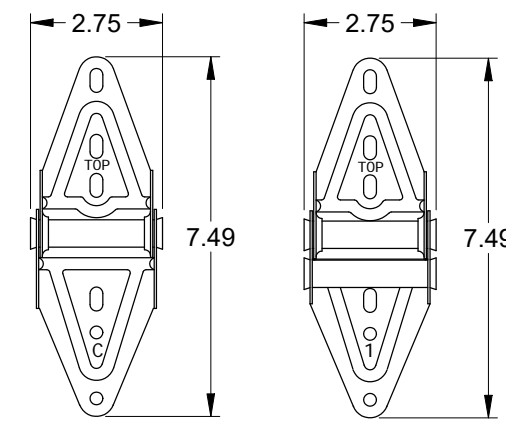

Center Hinge
.045 Galv. Steel

Edge Hinge
.086 Galv. Steel

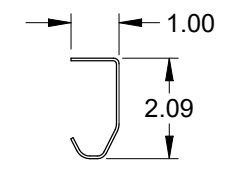

2" Track
.055 Galv. Steel

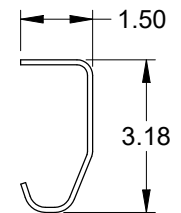

3" Track (Optional)
.105 Galv. Steel

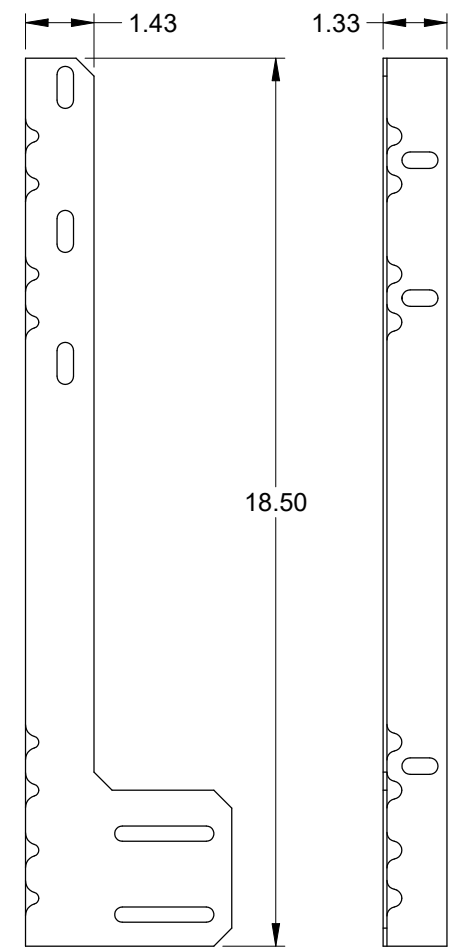

Jamb Angle
.078 min. Galv. Steel

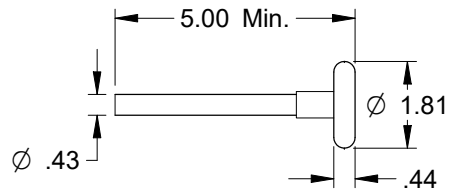

2" Roller
Nylon 11-ball (Std.)
Steel 10-ball (Opt.)

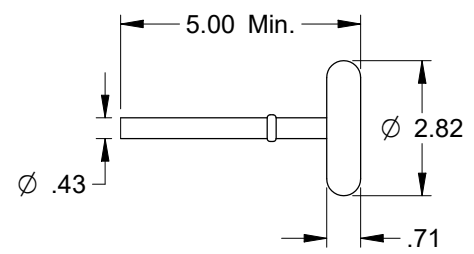

3" Roller
Steel 10-ball (Opt.)

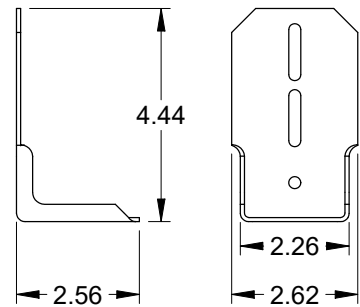

Top Fixture
.085 Galv. Steel

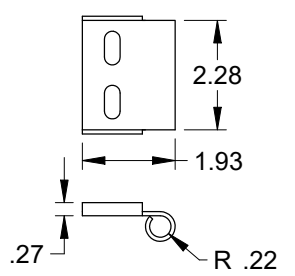

Roller Carrier
.085 Galv. Steel
Attached to Top Fixture
w/(2) Track Bolts and Whiz Nuts

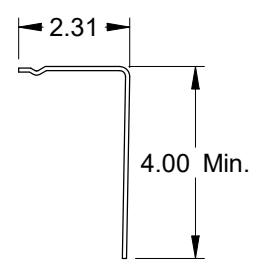

2" Angle Mount (Opt.)
.086 Galv. Steel

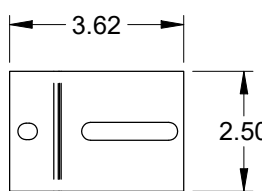

Track Clip (Opt.)
.09 Galv. Steel

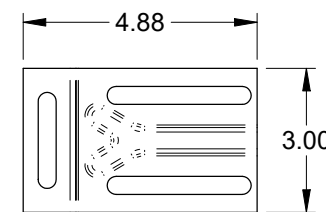

Track Splice Clip (Opt.)
.105 Galv. Steel

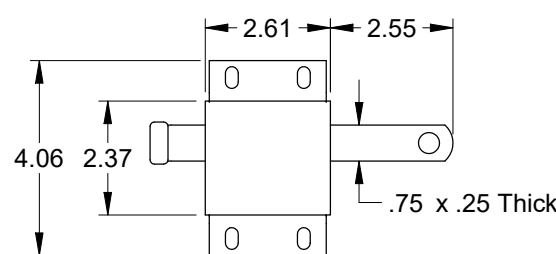

Slide Lock

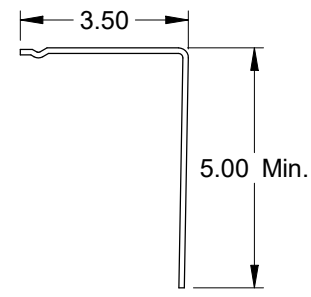

3" Angle Mount (Opt.)
.086 Min. Galv. Steel

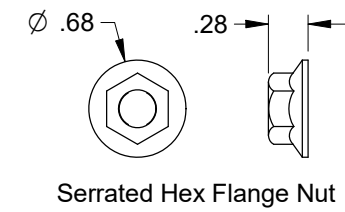

Serrated Hex Flange Nut

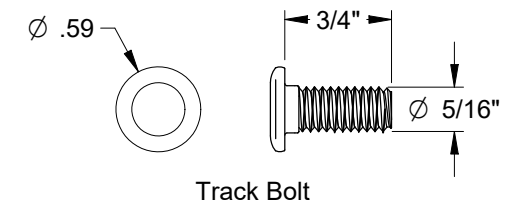

Track Bolt

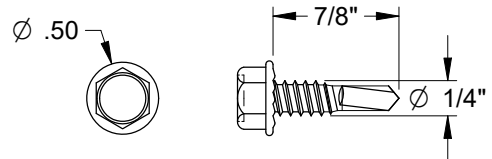

Self-Drilling Screw

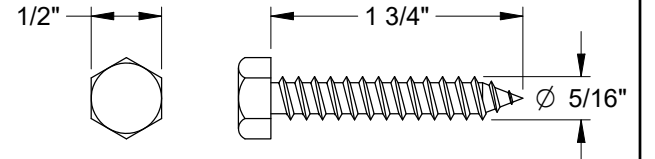

Hex Head Lag Screw

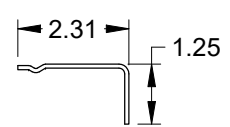

2" Clip Angle (Opt.)
.086 Galv. Steel

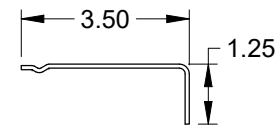

3" Clip Angle (Opt.)
.086 Galv. Steel



Scott A. Brown, P.E. Lic. No. 65940
Wendler Engineering Services, Inc.
698 Timber Creek Road, Dixon, IL 61021
FBPE CA Lic. No. 31544
Structural Adequacy for Wind Load

Scale: None
Drawn by: R. Frey
Checked by: G. Wedekind
Date: 10/04/22
ECO: 8593.03



Title: Spec, Wind Load EnergyCore		
No. P-2443	Sheet 3	Rev A

Angle Mount					
Jamb Type	Fastener Type	Minimum Embedment (in.)	Minimum Edge Distance (in.)	Maximum on Center Spacing (in.)	Allowable Tension Load (lbs.)
2500 PSI Min. Concrete	3/8" ITW Trubolt	2-1/2"	2-1/2"	36"	893
	1/4" Tapcon+ (Plus) with 1-1/8" OD Washer	2"	1-5/8"	36"	687
	1/4" x 2-5/8" Screw-Bolt+ with 9/16" OD Washer	2-1/2"	1-1/2"	36"	651
Steel	5/16" x 1" SAE J78, Min. AISI 1022 with 5/16" Washer	3/16"	1-1/2"	36"	971
Wood	5/16" x 1-3/4" Lag with 5/16" Washer	1-1/2"	1-1/2"	36"	352
Grout Filled CMU Block	3/8" Simpson Titen HD	2-3/4"	4"	36"	480

Alternate fasteners may be used if approved by a registered Professional Engineer.

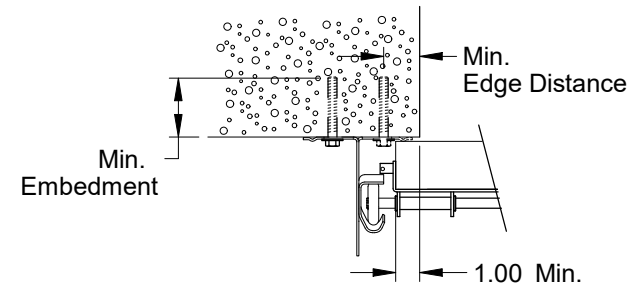

Track Assembly Attachment to 2500 PSI Min. Concrete

2" Angle mount turned-out standard (solid)
 2" Angle mount turned-in optional (dashed)
 3" Angle mount available

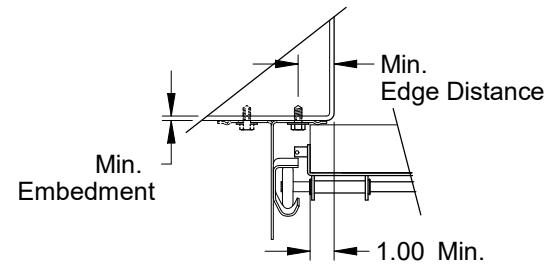

Track Assembly Attachment to 3/16" Min. Steel Jamb

2" Angle mount turned-out standard (solid)
 2" Angle mount turned-in optional (dashed)
 3" Angle mount available

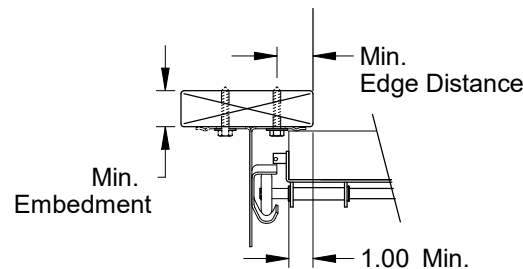

Track Assembly Attachment to Wood Jamb

2" Angle mount turned-out standard (solid)
 2" Angle mount turned-in optional (dashed)
 3" Angle mount available

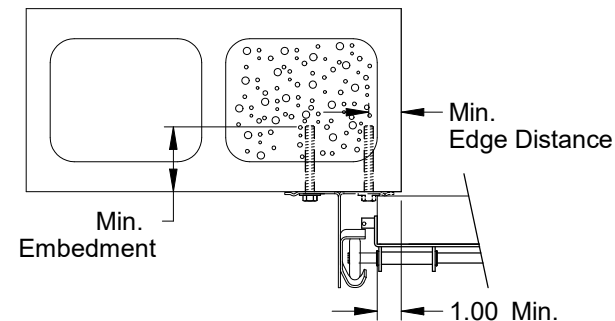

Track Assembly Attachment to Grout Filled CMU Block

2" Angle mount turned-out standard (solid)
 2" Angle mount turned-in optional (dashed)
 3" Angle mount available

Pre-Assembled Clip Angle					
Jamb Type	Fastener Type	Minimum Embedment (in.)	Minimum Edge Distance (in.)	Maximum on Center Spacing (in.)	Allowable Tension Load (Lbs.)
2500 PSI Min. Concrete	3/8" ITW Trubolt	2-1/2"	2-1/2"	24"	893
	1/4" Tapcon+ (Plus) with 1-1/8" OD Washer	2"	1-5/8"	24"	687
	1/4" x 2-5/8" Screw-Bolt+ with 9/16" OD Washer	2-1/2"	1-1/2"	24"	651
Steel	5/16" x 1" SAE J78, Min. AISI 1022 with 5/16" Washer	3/16"	1-1/2"	24"	971
Wood	5/16" x 1-3/4" Lag with 5/16" Washer	1-1/2"	1-1/2"	24"	352
Grout Filled CMU Block	3/8" Simpson Titen HD	2-3/4"	4"	24"	480

Alternate fasteners may be used if approved by a registered Professional Engineer.

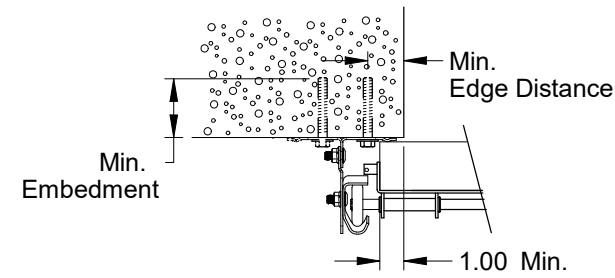

Pre-Assembled Track Assembly Attachment to 2500 PSI Min. Concrete

2" Clip angle turned-in standard (solid)
 2" Clip angle turned-out optional (dashed)
 3" Clip angle available

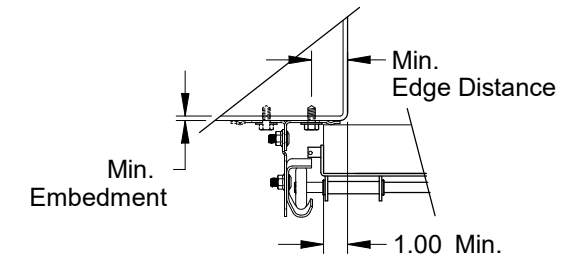

Pre-Assembled Track Assembly Attachment to 3/16" Min. Steel Jamb

2" Clip angle turned-in standard (solid)
 2" Clip angle turned-out optional (dashed)
 3" Clip angle available

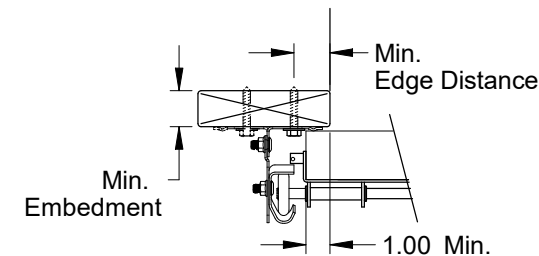

Pre-Assembled Track Assembly Attachment to Wood Jamb

2" Clip angle turned-in standard (solid)
 2" Clip angle turned-out optional (dashed)
 3" Clip angle available

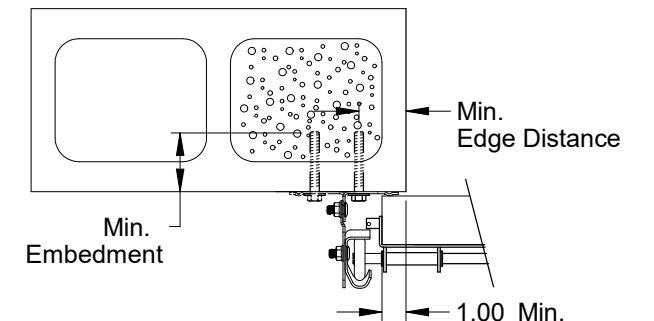

Pre-Assembled Track Assembly Attachment to Grout Filled CMU Block

2" Clip angle turned-in standard (solid)
 2" Clip angle turned-out optional (dashed)
 3" Clip angle available



Scott A. Brown, P.E. Lic. No. 65940
 Wender Engineering Services, Inc.
 698 Timber Creek Road, Dixon, IL 61021
 FBPE CA Lic. No. 31544
 Structural Adequacy for Wind Load

Scale: None	 1101 East River Road Dixon, IL. 61021	Title: Spec, Wind Load EnergyCore	
Drawn by: R. Frey		No. P-2443	Sheet 4
Checked by: G. Wedekind			
Date: 10/04/22		Rev A	
ECO: 8593.03			