

Interior Skin
.015 Thick G-40 galvanized steel with an epoxy primer and baked on polyester finish which is roll-formed with a texture embossed skin.

Exterior Skin
.015 Thick G-40 galvanized steel with an epoxy primer and baked on polyester finish which is roll-formed with a texture embossed skin.

Hardware Plate .035 thick

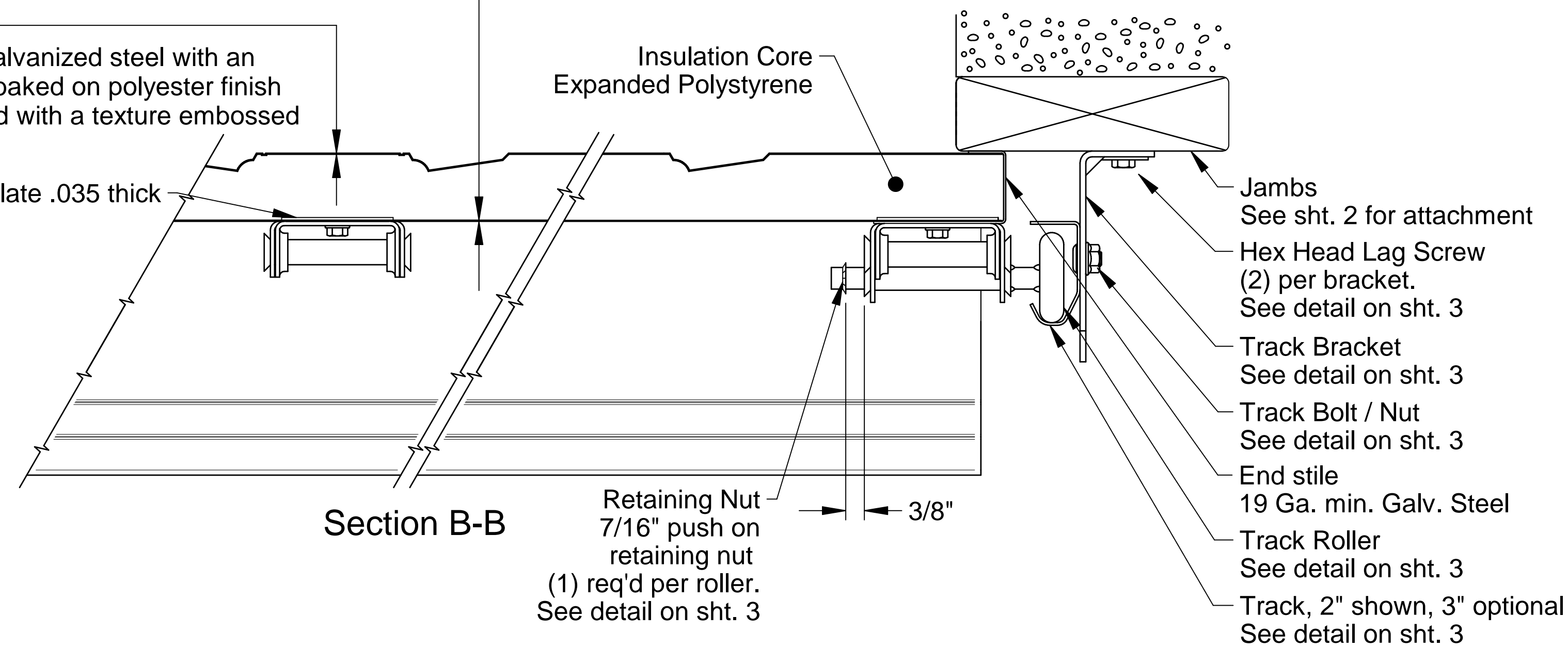

Door Height
8'-0" High shown
Other door heights available up to 18'-0" using 18", 21" or 24" high sections

Steel Reinforcement
(1) Box strut per section fastened to all center and end stiles using (2) self-drilling screws at each stile.

Embedded Hardware Plates

Locks required on doors not electrically operated.

Vents (Optional)
Vent openings may be located in bottom section as allowed by local code

Spring Counterbalance
Spring wire individually calculated to counterbalance door. Quantity and size of spring will vary based on door size.

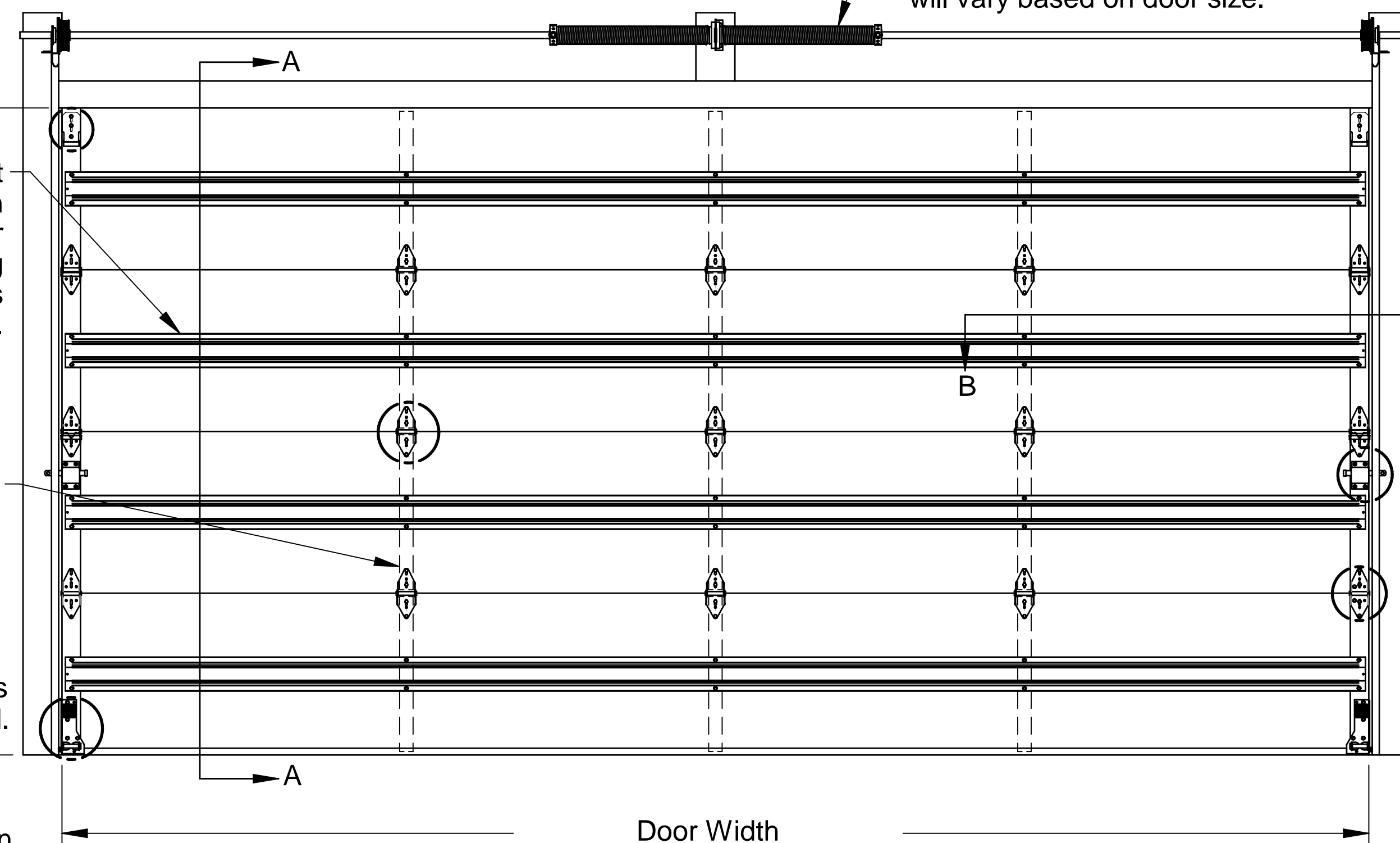

Door Width
See chart for other door widths (16'-2" Ranch shown)
Interior Elevation

Doors tested per ANSI/DASMA 108 for static air pressure

Max. Door Width	Commercial Encore								
	Ctr. Hngs. per Sect.	Colonial Design Loads		Ranch Design Loads		Carriage House Design Loads			
8'-2"	1	59.1	-69.5	1	59.1	-69.5	1	59.1	-69.5
9'-2"	1	52.5	-61.8	1	52.5	-61.8	1	52.5	-61.8
10'-2"	2	49.3	-55.7	1	42.5	-50.1	1	42.5	-50.1
12'-2"	2	41.1	-46.4	2	41.1	-46.4	2	36.7	-41.5
14'-2"	2	31.4	-35.5	2	31.4	-35.5	2	31.4	-35.5
16'-2"	3	27.8	-33.1	3	27.8	-33.1	3	27.8	-33.1
18'-2"	3	22.0	-26.2	3	22.0	-26.2	3	20.2	-24.8
20'-2"	4	19.3	-21.5	4	19.3	-21.5	4	19.3	-21.5



Scott A. Brown, P.E. Lic. No. 65940
Wendler Engineering Services, Inc.
698 Timber Creek Road, Dixon, IL 61021
FBPE CA Lic. No. 31544
Structural Adequacy for Wind Load

Scale: None	8593.01	05/24/22	Date: 05/24/22
Drawn by: R. Frey	ECO	Date	ECO: 8593.01
Checked by: G. Wedekind			
Rev. A	Description		

RAYNOR
1101 East River Road
Dixon, IL 61021

Title: Spec, Wind Load Commercial Encore	No. P-2447	Sheet 1 of 4	Rev A
--	------------	--------------	-------

Jamb Attachment Notes:

1. Maximum Positive Load per Jamb = $(12'-0" \times 41.1 \text{ PSF}) / 2 = 247 \text{ lbs. per foot.}$
2. Maximum Negative Load per Jamb = $(12'-0" \times -46.4 \text{ PSF}) / 2 = 279 \text{ lbs. per foot.}$
3. Design of the supporting structure shall be the sole responsibility of the building designer and shall be designed for the jamb loads listed in notes 1 and 2.
4. Alternate jamb attachments may be used if approved by a registered Professional Engineer.
5. DASMA Technical Data Sheet TDS-161 may be used for alternate jamb attachments.
6. 3/8" diameter lag screws required 1/4" pilot hole and 1-1/2" minimum required distance.
7. Masonry fasteners by others.

2x6 Attachment to Structure						
Structure Type	Fastener Type	Minimum Embedment	Minimum Edge Distance	Minimum on Center Spacing	Maximum on Center Spacing	Allowable Tension Load
2500 PSI Min. Concrete	1/4" Tapcon+ (Plus) with 1-1/8" OD Washer	2"	2.5	6"	24"	526
Southern Pine	3/8" x 3" Lag with 1-1/8" OD Washer	1.50"	1.50"	1.50"	24"	655
Spruce Pine Fir	3/8" x 3" LAG with 1-1/8" OD Washer	1.50"	1.50"	1.50"	23"	482

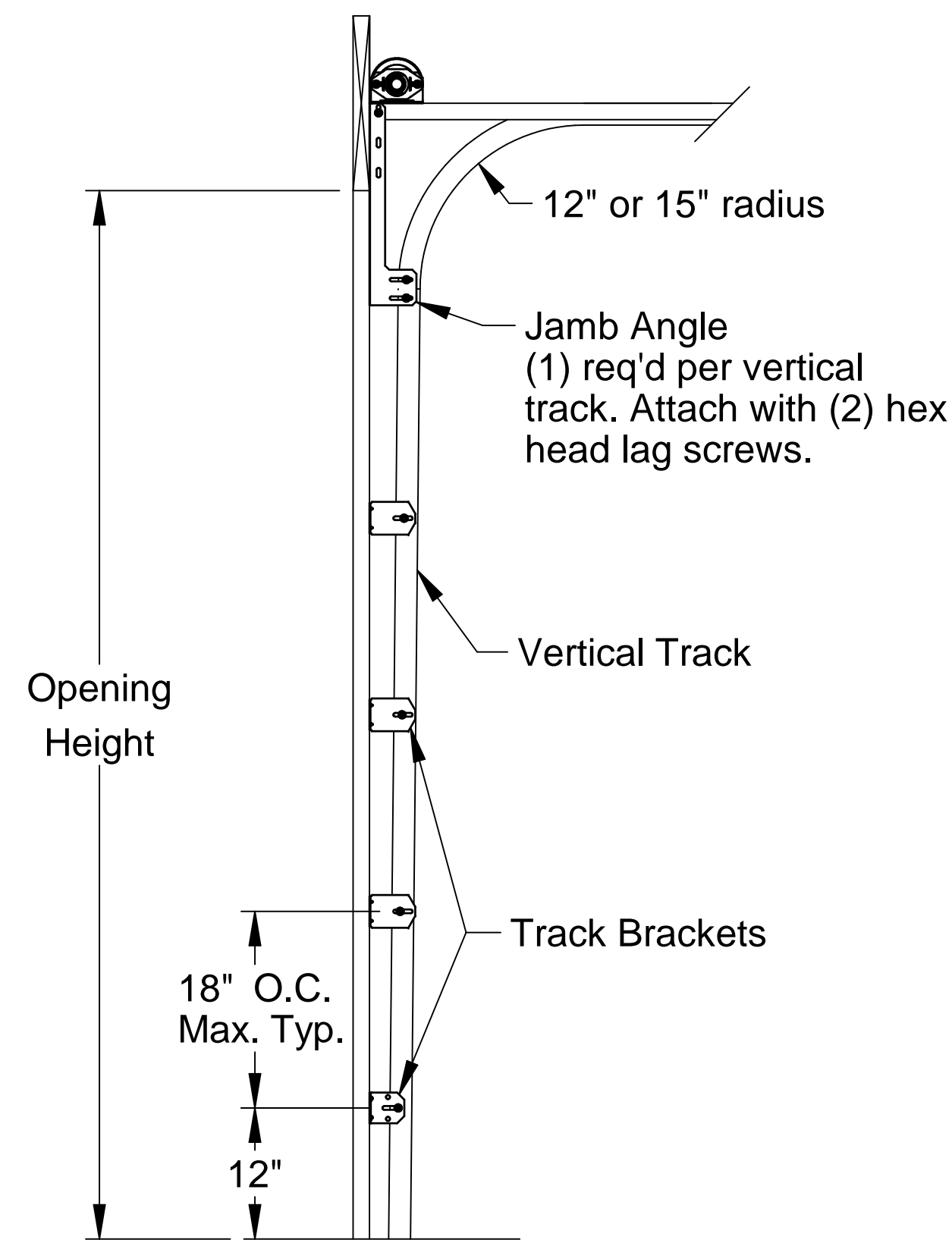
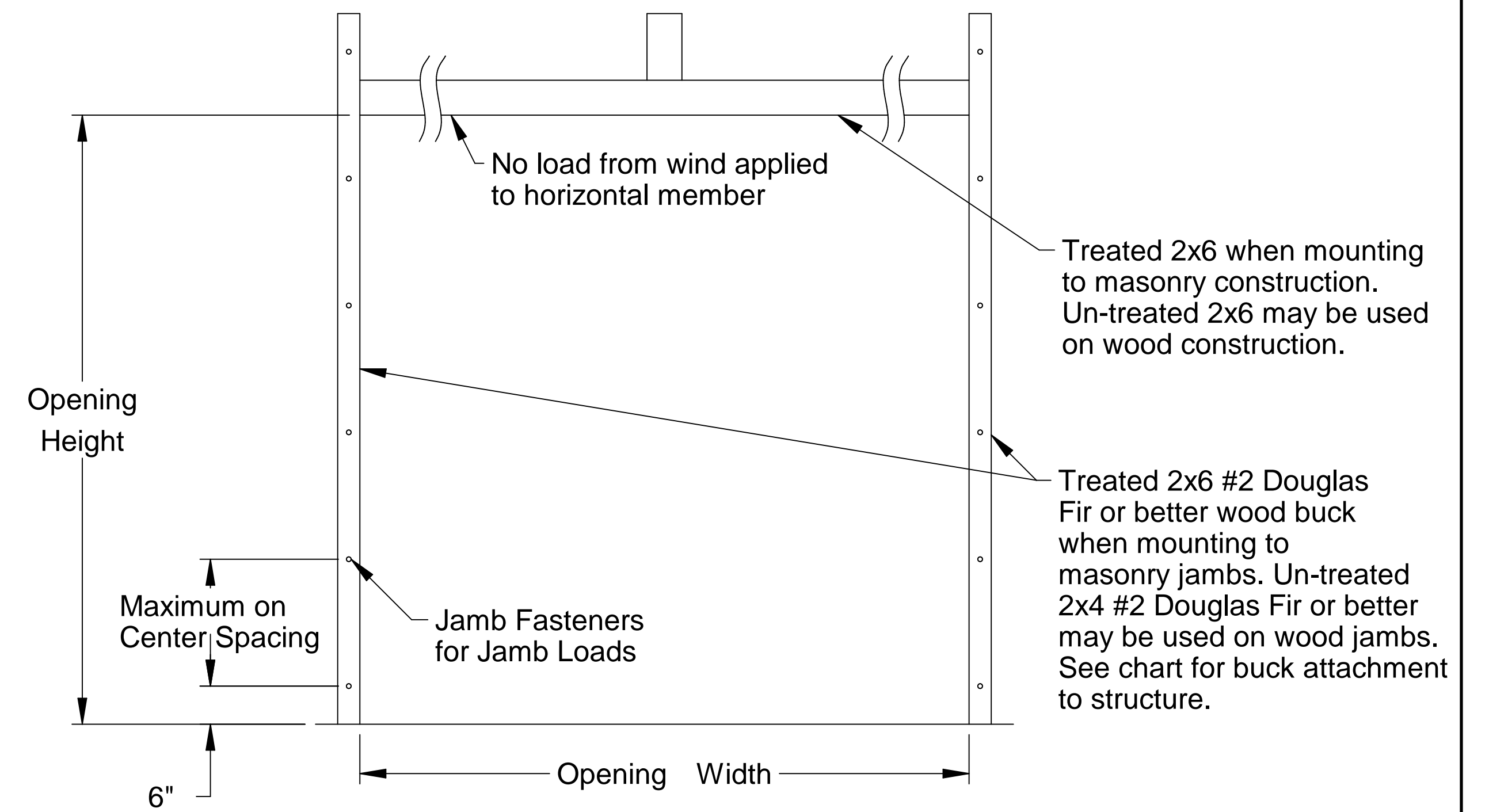

**Typical Track Installation
Bracket Mount
Wood Jamb**
Normal headroom track shown, low headroom, lift clearance and verical lift track available.

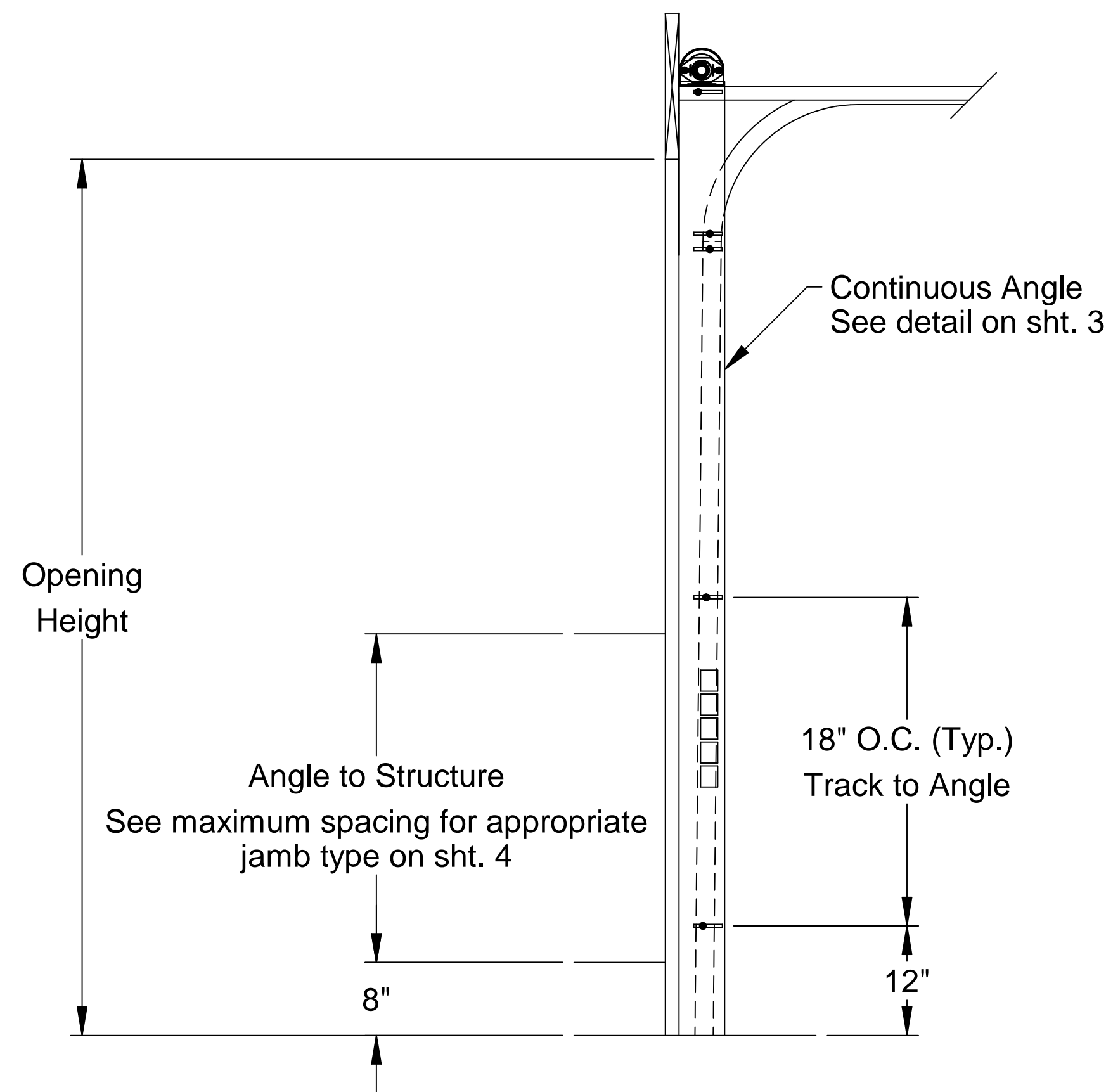

**Typical Track Installation
Angle Mount
Wood, Steel or Concrete Jamb**
Normal headroom track shown, low headroom, lift clearance and verical lift track available.

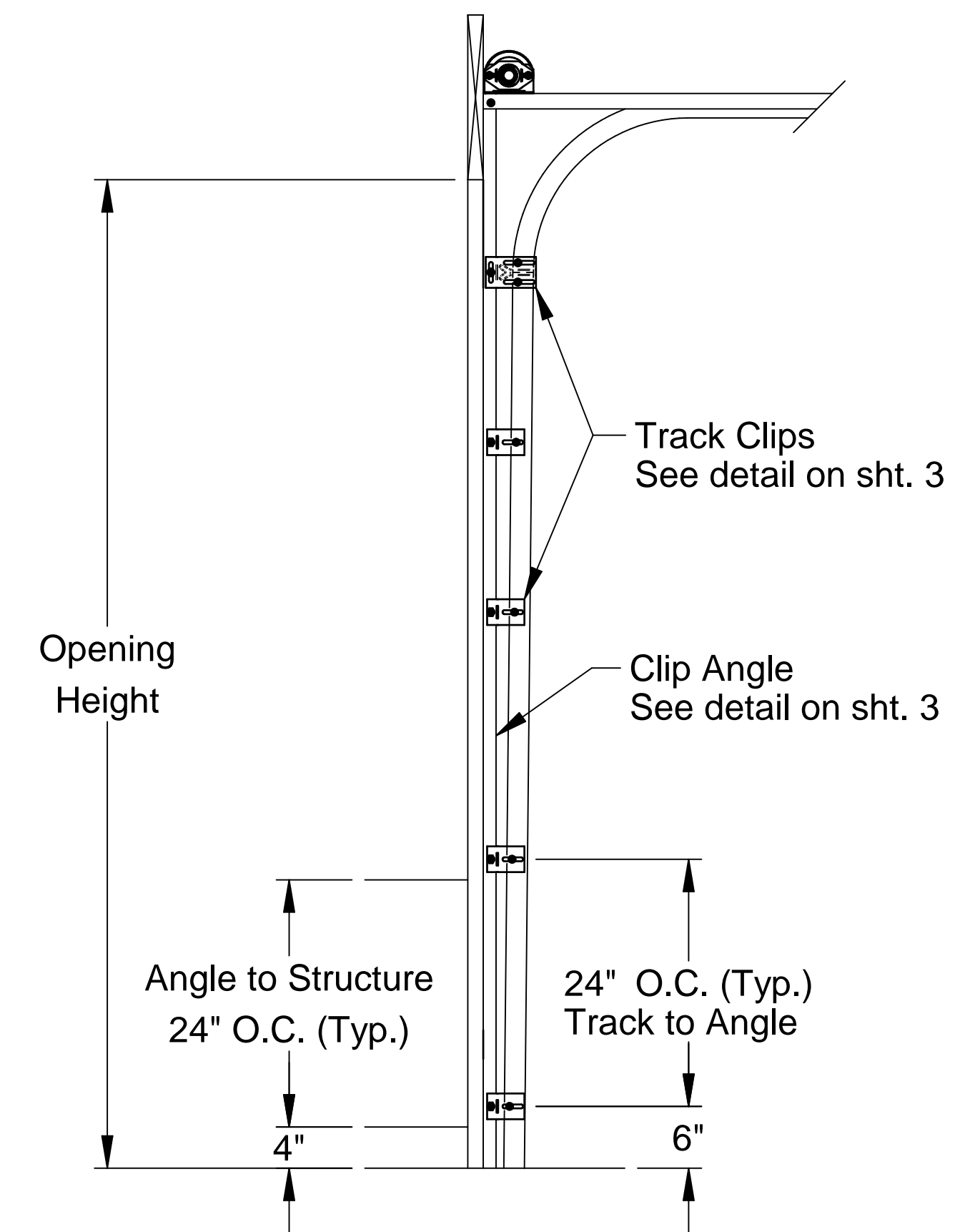

**Typical Track Installation
Pre-Assembled Clip Angle
Wood, Steel or Concrete Jamb**
Normal headroom track shown, lift clearance and verical lift track available.



Scott A. Brown, P.E. Lic. No. 65940
Wendler Engineering Services, Inc.
698 Timber Creek Road, Dixon, IL 61021
FBPE CA Lic. No. 31544
Structural Adequacy for Wind Load

Scale: None	 1101 East River Road Dixon, IL 61021	Title: Spec, Wind Load Commercial Encore	
Drawn by: R. Frey		No. P-2447	Sheet 2
Checked by: G. Wedekind			
Date: 05/24/22 ECO: 8593.01			

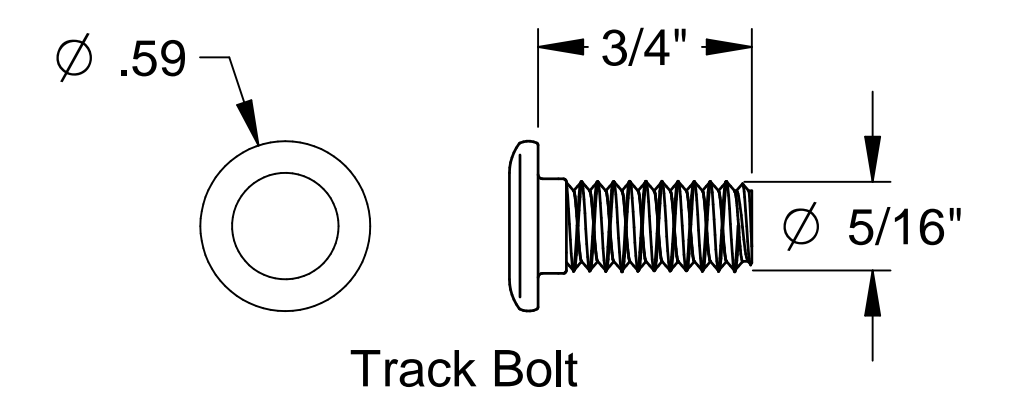
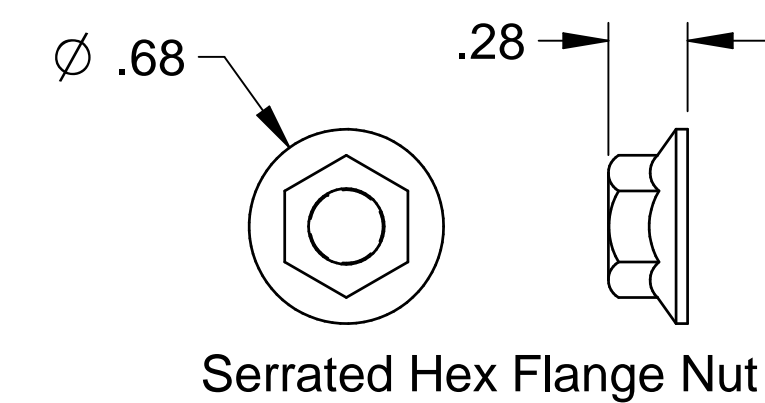
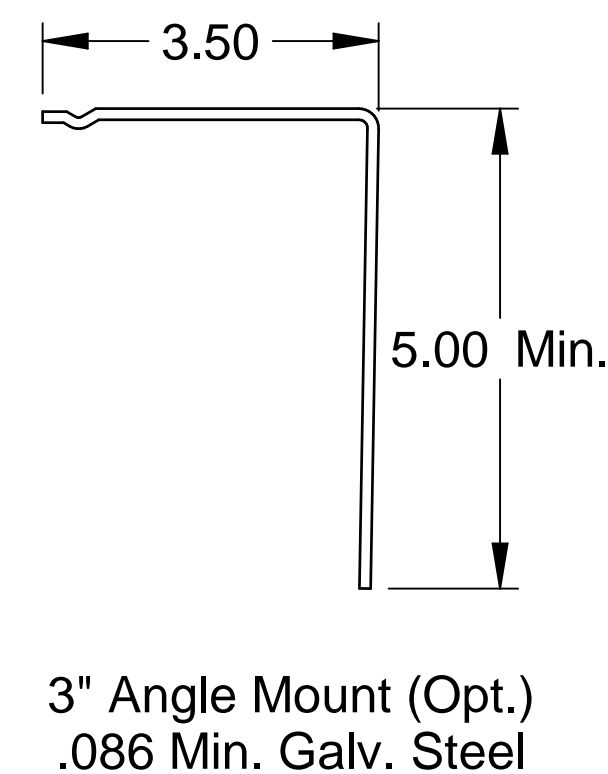
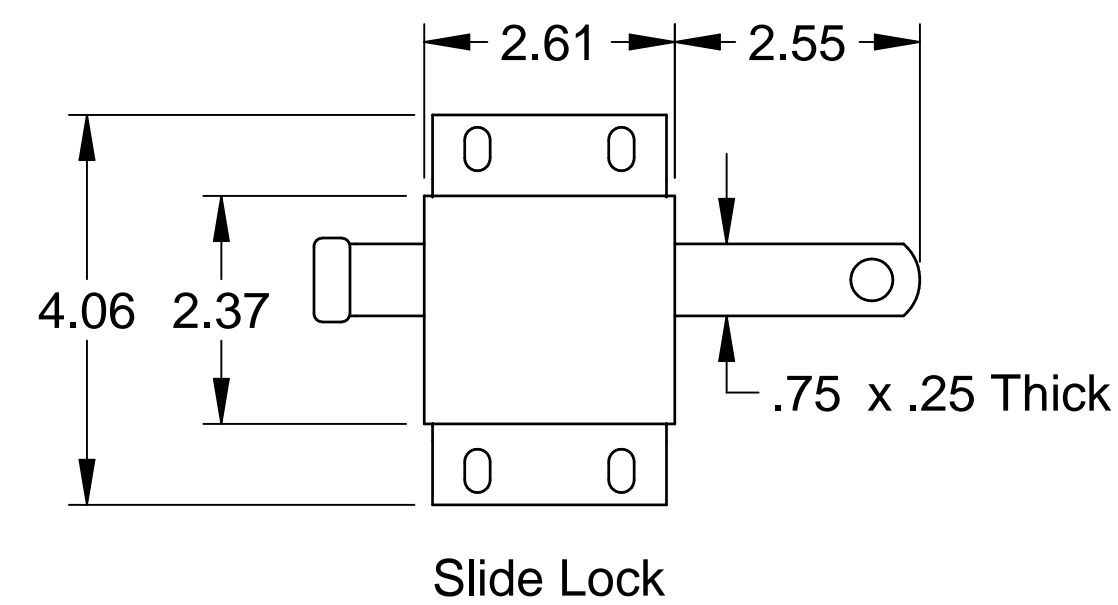
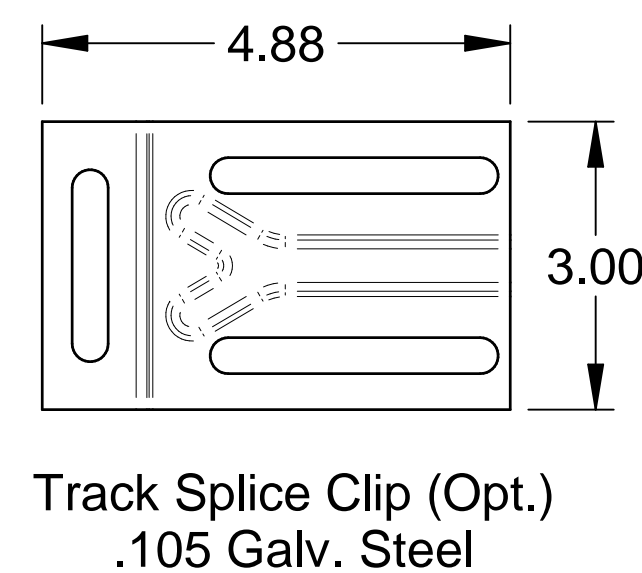
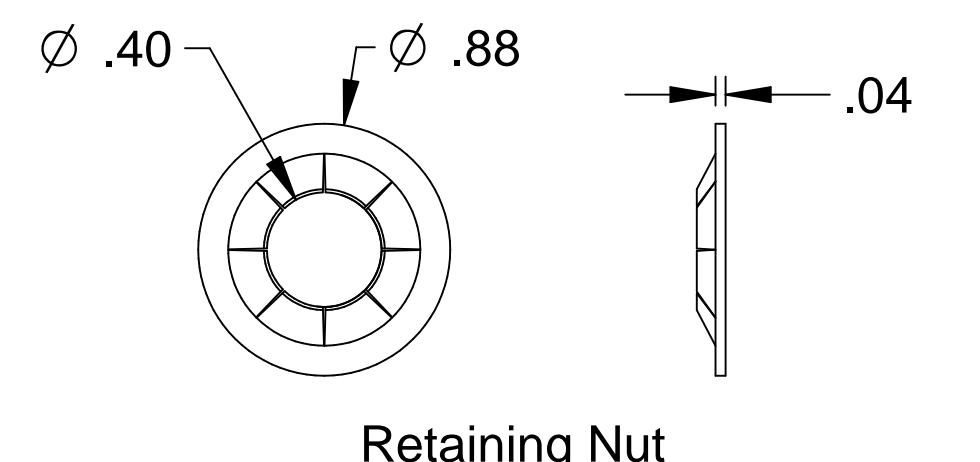
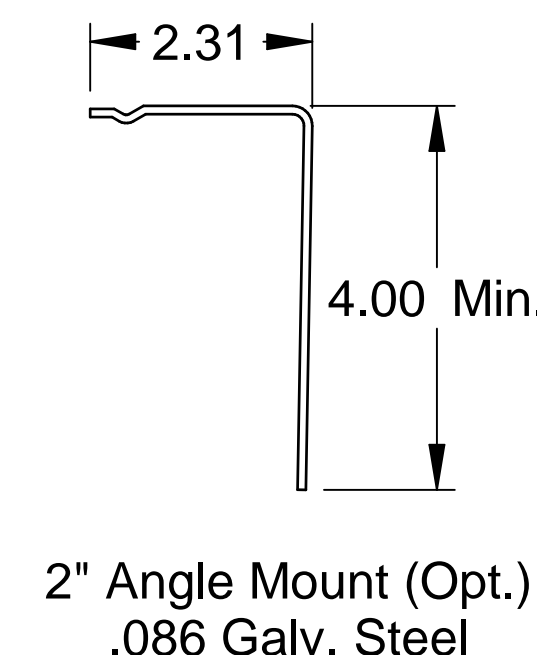
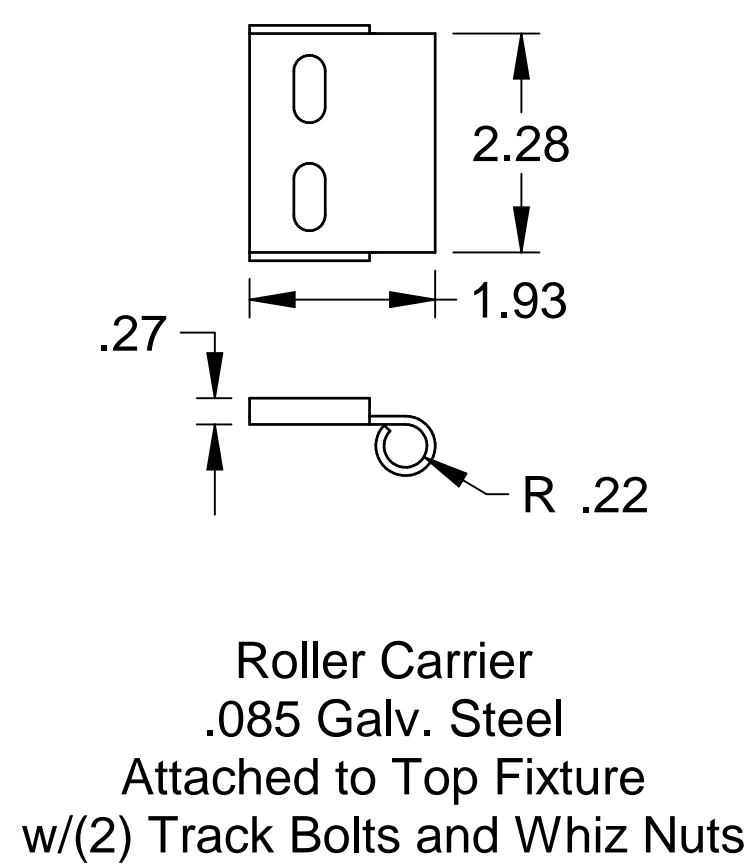
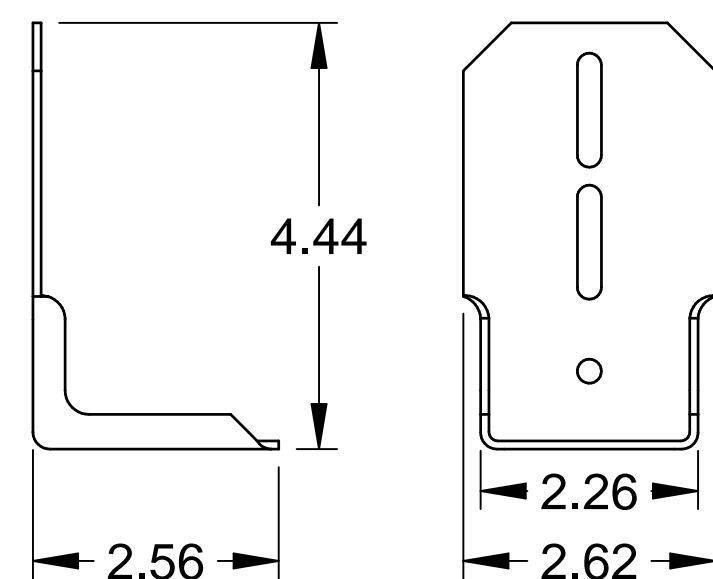
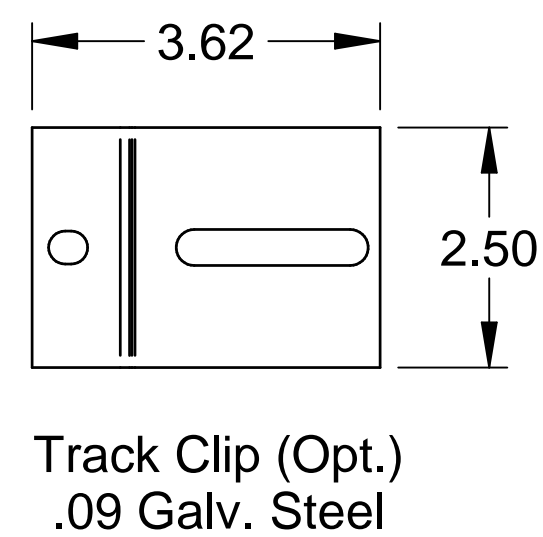
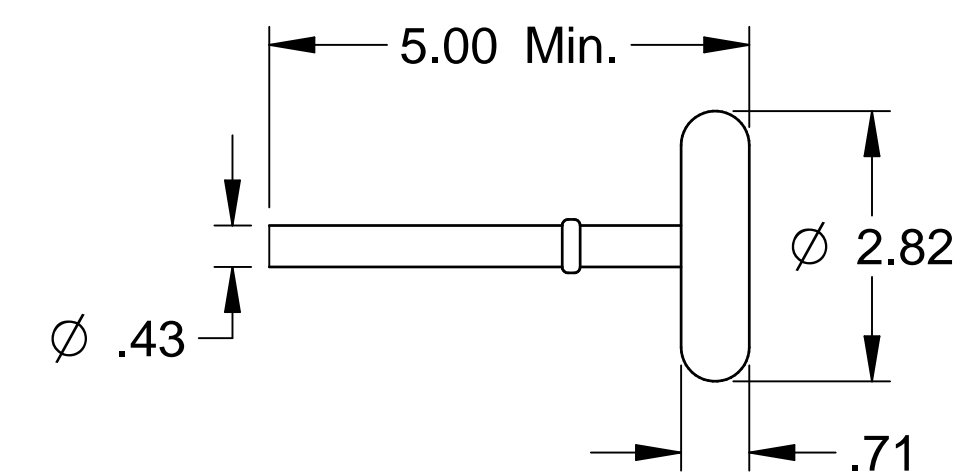
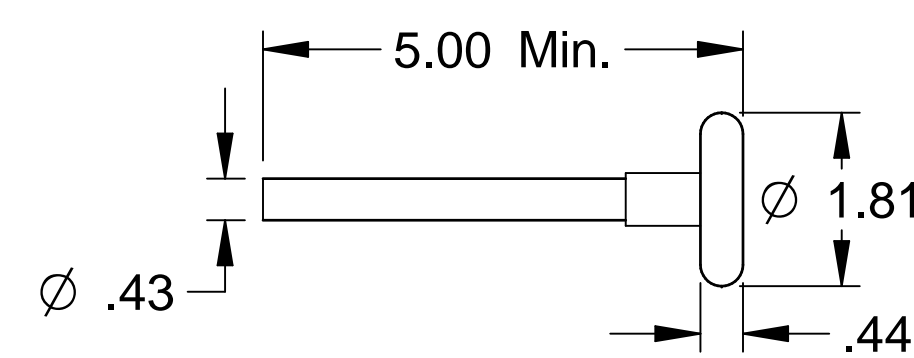
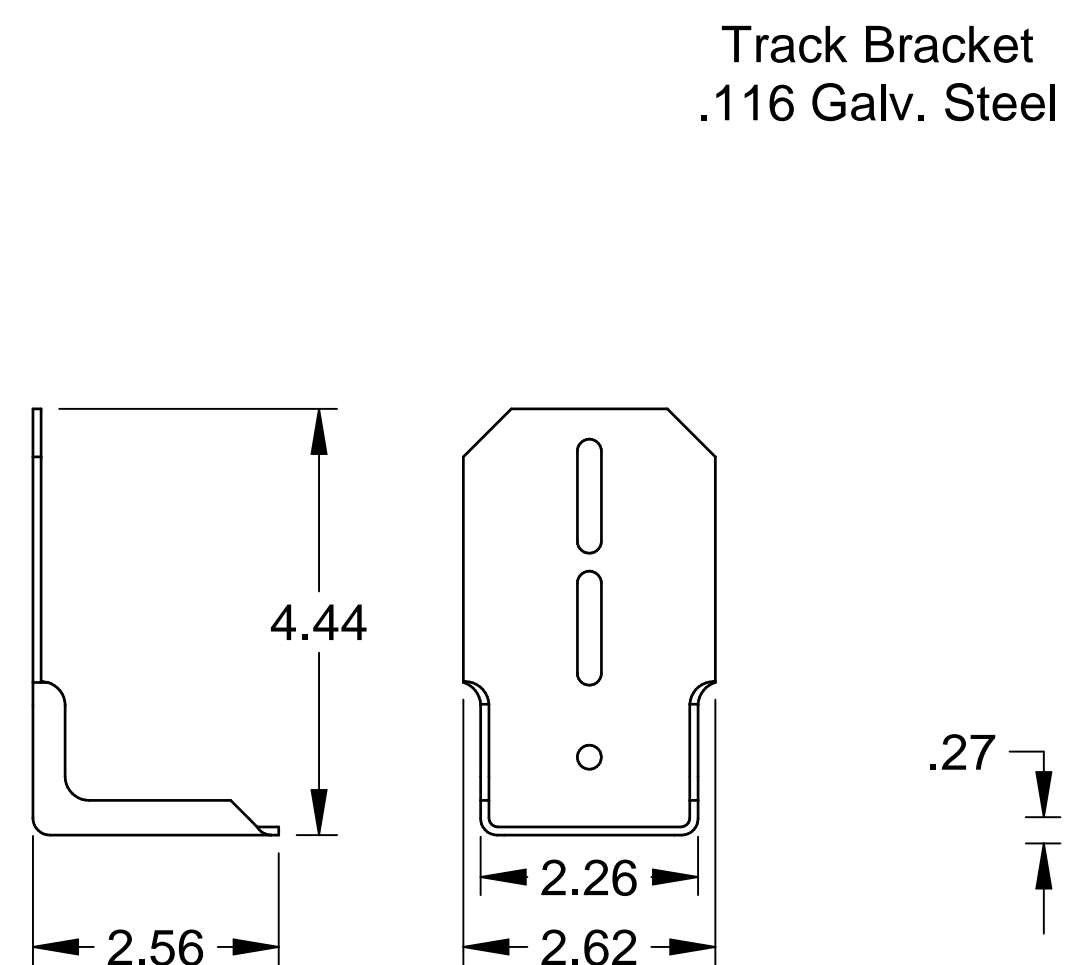
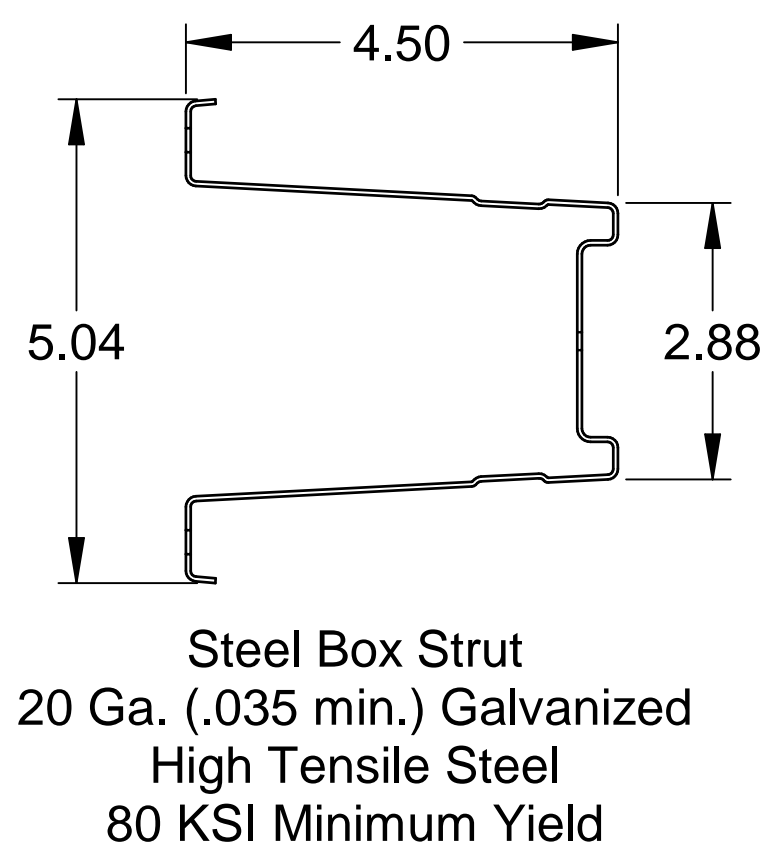
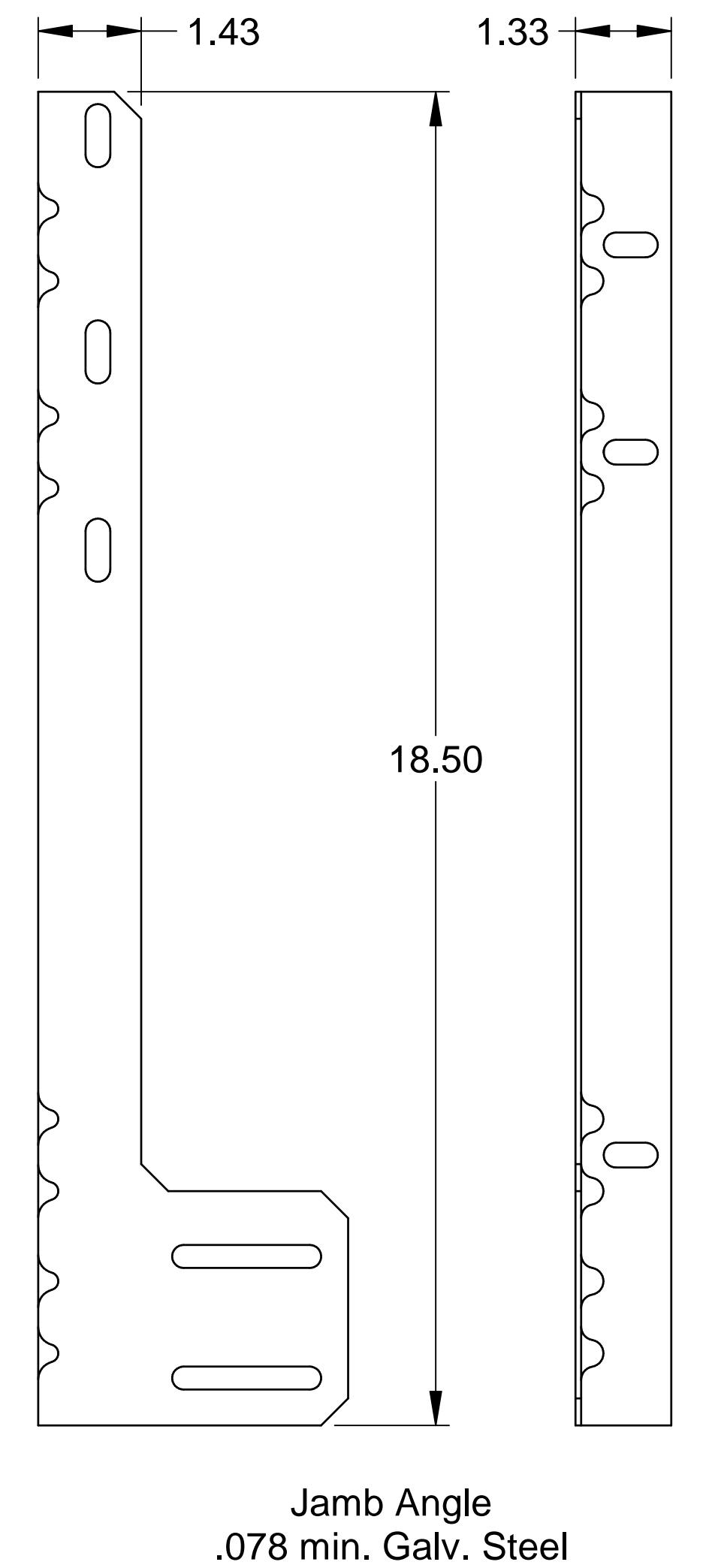
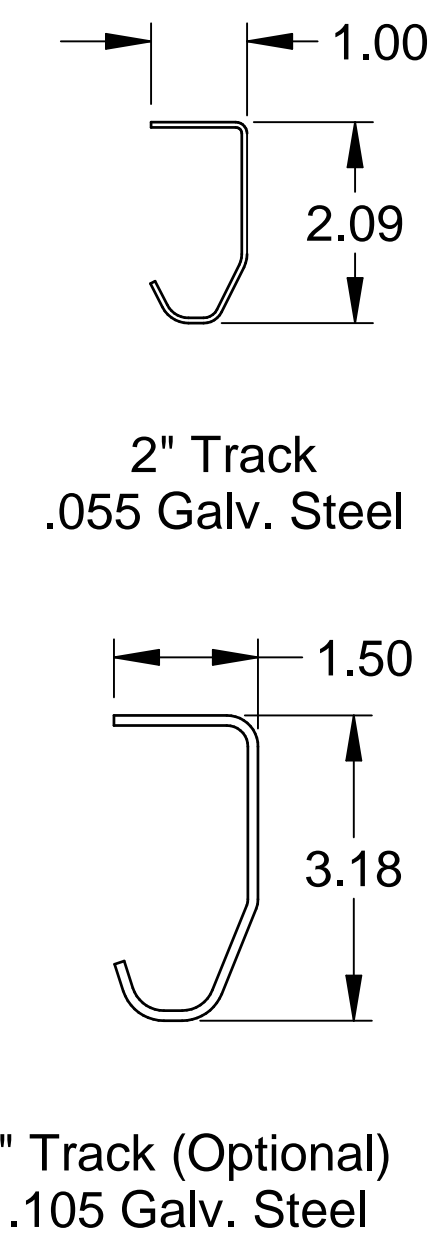
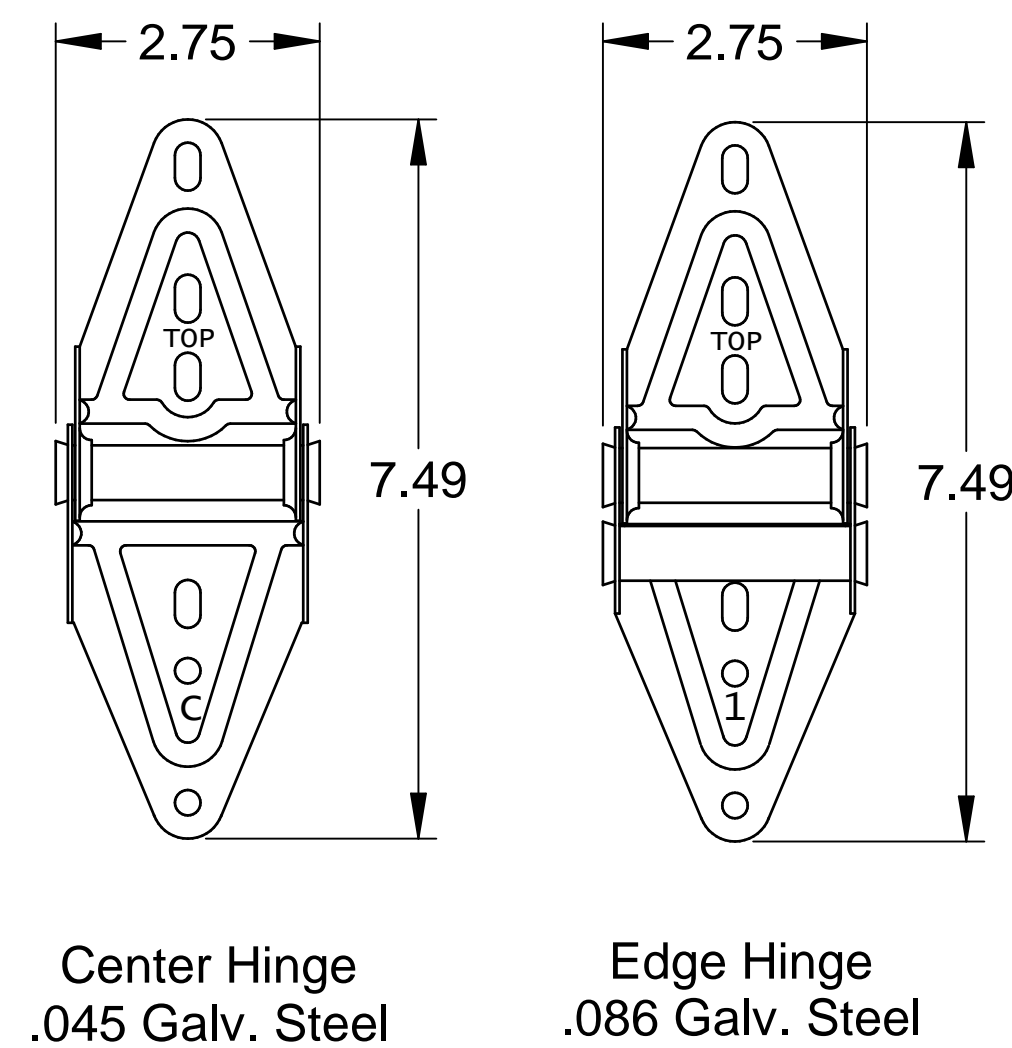
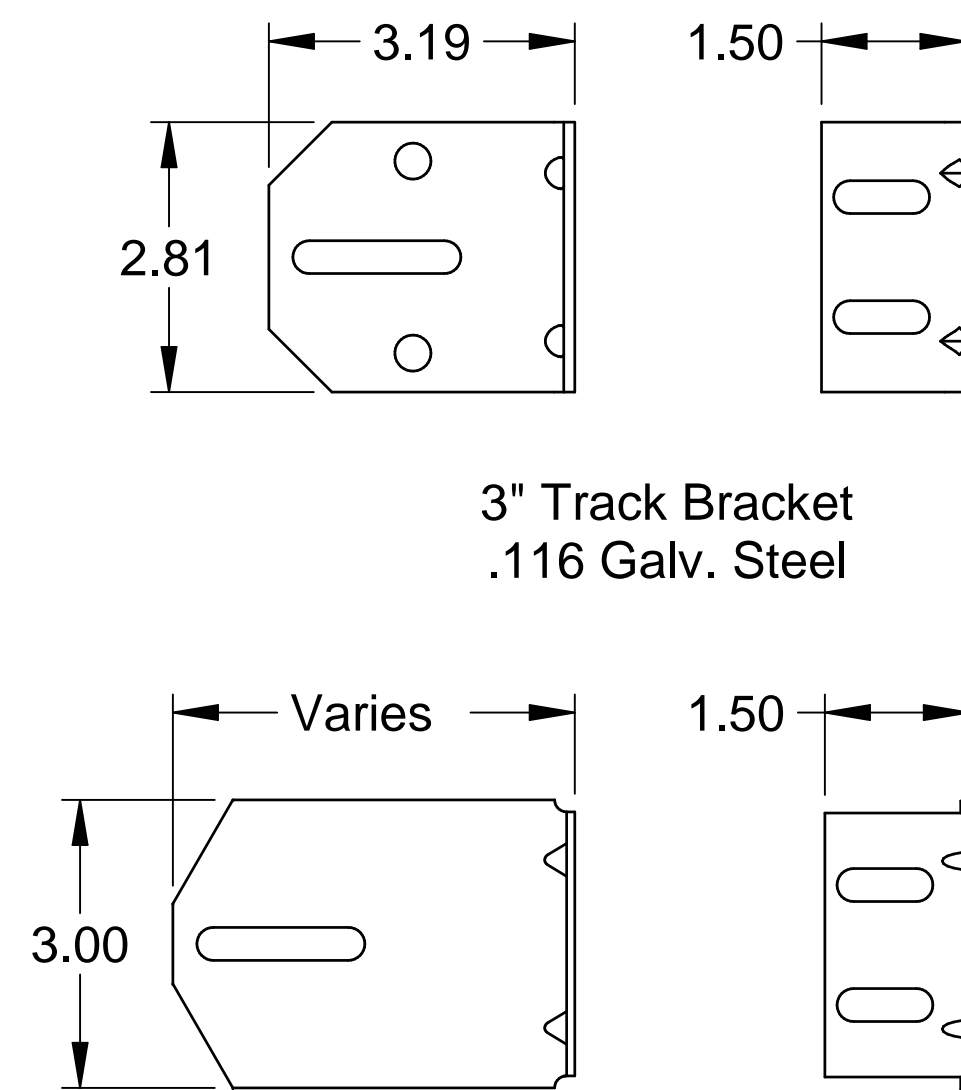
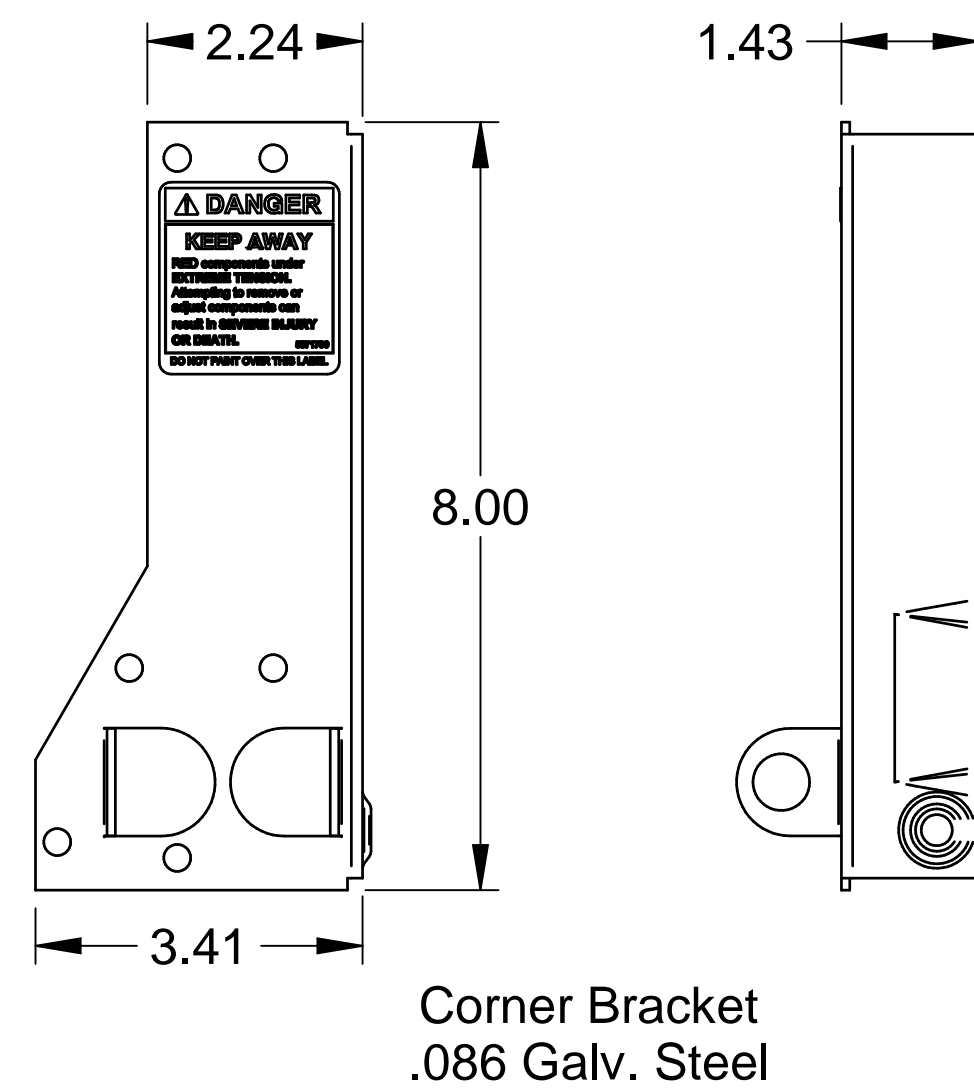

Scott A. Brown, P.E. Lic. No. 65940
Wendler Engineering Services, Inc.
698 Timber Creek Road, Dixon, IL 61021
FBPE CA Lic. No. 31544
Structural Adequacy for Wind Load

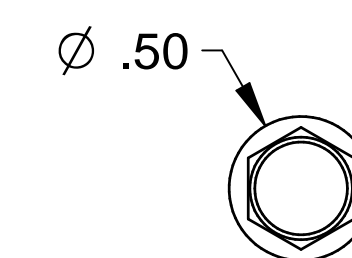
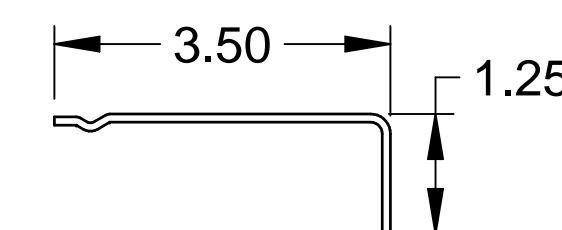
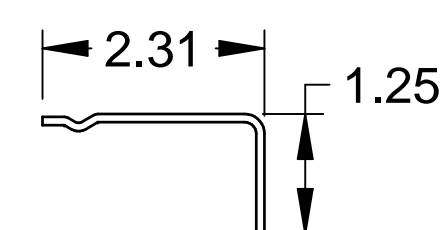

Self-Drilling Screw

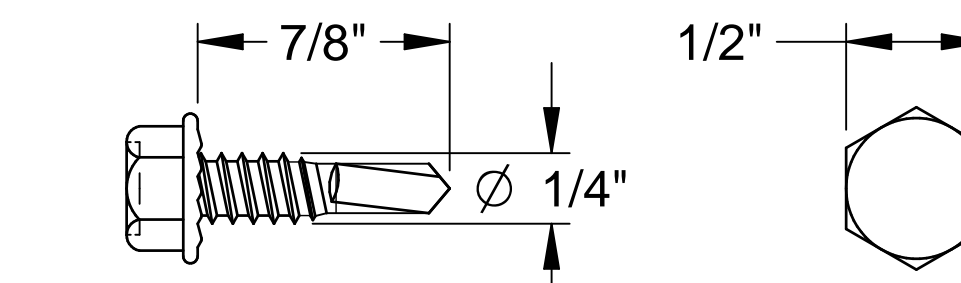

Hex Head Lag Screw

Scale: None
Drawn by: R. Frey
Checked by: G. Wedekind
Date: 05/24/22
ECO: 8593.01



1101 East River Road
Dixon, IL 61021

Title: Spec, Wind Load Commercial Encore		
No. P-2447	Sheet 3	Rev A

Angle Mount					
Jamb Type	Fastener Type	Minimum Embedment (in.)	Minimum Edge Distance (in.)	Maximum on Center Spacing (in.)	Allowable Tension Load (lbs.)
2500 PSI Min. Concrete	3/8" ITW Trubolt	2-1/2"	2-1/2"	36"	893
	1/4" Tapcon+ (Plus) with 1-1/8" OD Washer	2"	1-5/8"	18"	687
	1/4" x 2-5/8" Screw-Bolt+ with 9/16" OD Washer	2-1/2"	1-1/2"	18"	651
Steel	5/16" x 1" SAE J78, Min. AISI 1022 with 5/16" Washer	3/16"	1-1/2"	36"	971
Wood	5/16" x 1-3/4" Lag with 5/16" Washer	1-1/2"	1-1/2"	12"	352
Grout Filled CMU Block	3/8" Simpson Titen HD	2-3/4"	4"	18"	480

Alternate fasteners may be used if approved by a registered Professional Engineer.

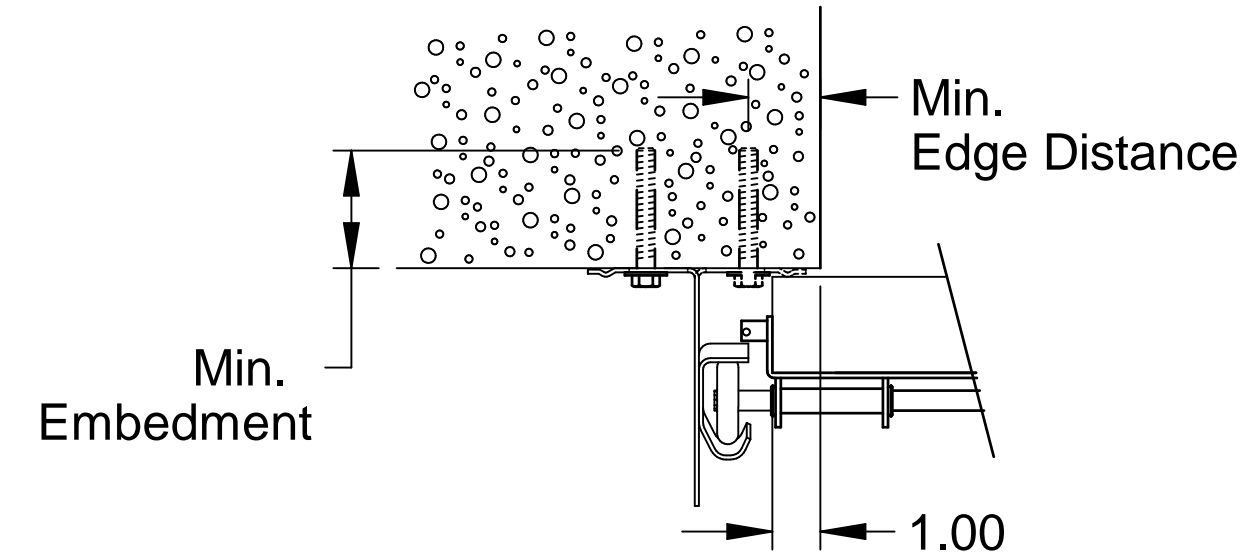

Track Assembly Attachment to 2500 PSI Min. Concrete

2" Angle mount turned-out standard (solid)
2" Angle mount turned-in optional (dashed)
3" Angle mount available

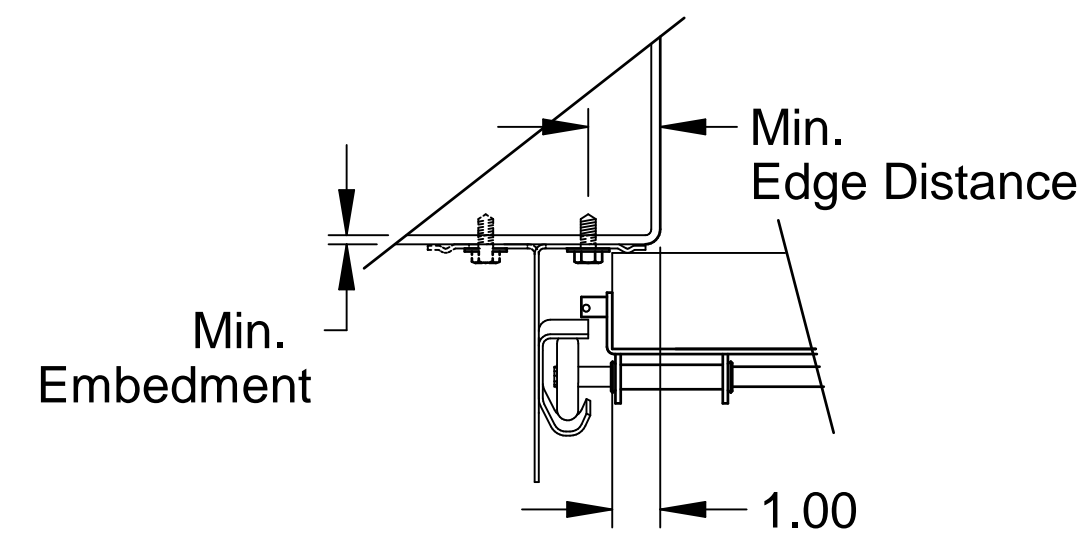

Track Assembly Attachment to 3/16" Min. Steel Jamb

2" Angle mount turned-out standard (solid)
2" Angle mount turned-in optional (dashed)
3" Angle mount available

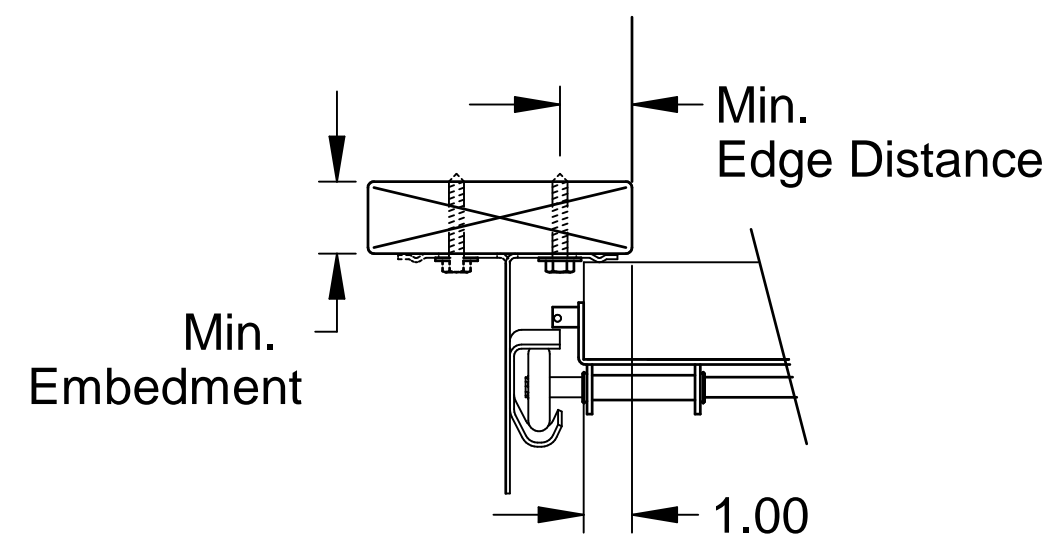

Track Assembly Attachment to Wood Jamb

2" Angle mount turned-out standard (solid)
2" Angle mount turned-in optional (dashed)
3" Angle mount available

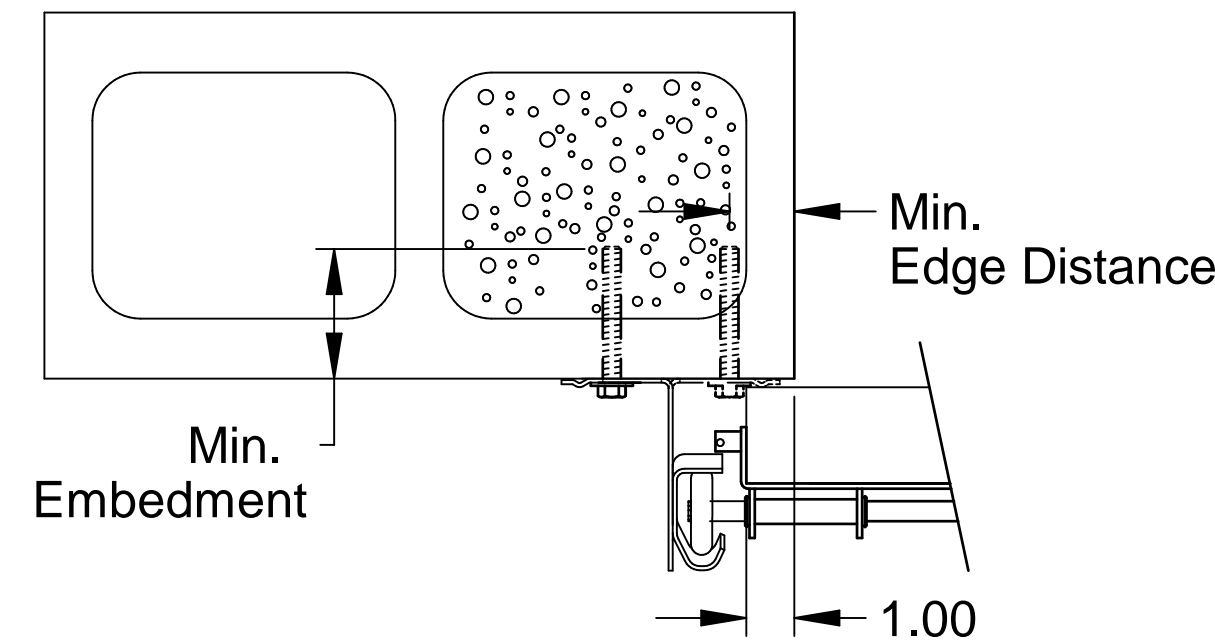

Track Assembly Attachment to Grout Filled CMU Block

2" Angle mount turned-out standard (solid)
2" Angle mount turned-in optional (dashed)
3" Angle mount available

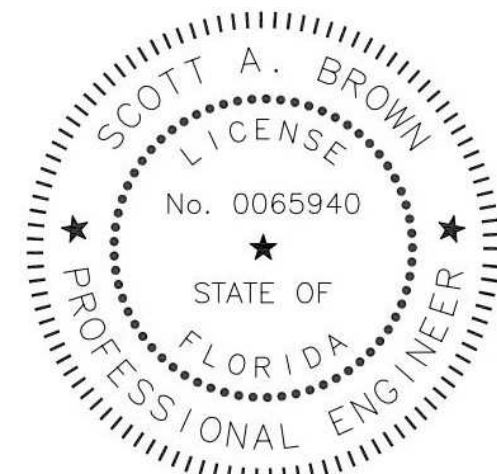

Scott A. Brown, P.E. Lic. No. 65940
Wendler Engineering Services, Inc.
698 Timber Creek Road, Dixon, IL 61021
FBPE CA Lic. No. 31544
Structural Adequacy for Wind Load

Pre-Assembled Clip Angle					
Jamb Type	Fastener Type	Minimum Embedment (in.)	Minimum Edge Distance (in.)	Maximum on Center Spacing (in.)	Allowable Tension Load (Lbs.)
2500 PSI Min. Concrete	3/8" ITW Trubolt	2-1/2"	2-1/2"	24"	893
	1/4" Tapcon+ (Plus) with 1-1/8" OD Washer	2"	1-5/8"	24"	687
	1/4" x 2-5/8" Screw-Bolt+ with 9/16" OD Washer	2-1/2"	1-1/2"	24"	651
Steel	5/16" x 1" SAE J78, Min. AISI 1022 with 5/16" Washer	3/16"	1-1/2"	24"	971
Wood	5/16" x 1-3/4" Lag with 5/16" Washer	1-1/2"	1-1/2"	*12"	352
Grout Filled CMU Block	3/8" Simpson Titen HD	2-3/4"	4"	*12"	480

* Field drilling req'd.

Alternate fasteners may be used if approved by a registered Professional Engineer.

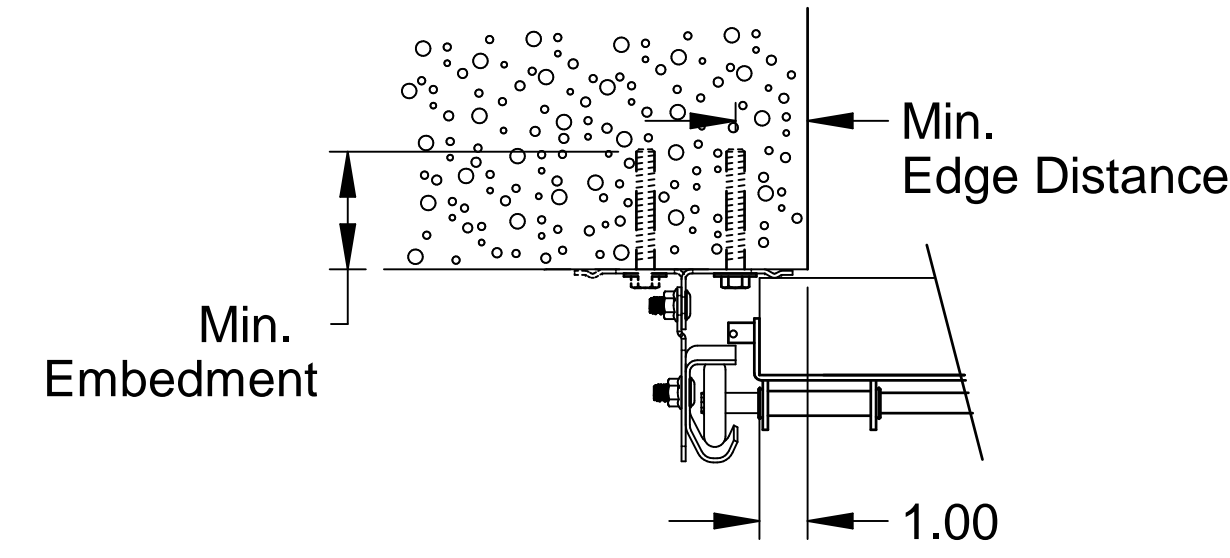

Pre-Assembled Track Assembly Attachment to 2500 PSI Min. Concrete

2" Clip angle turned-in standard (solid)
2" Clip angle turned-out optional (dashed)
3" Clip angle available

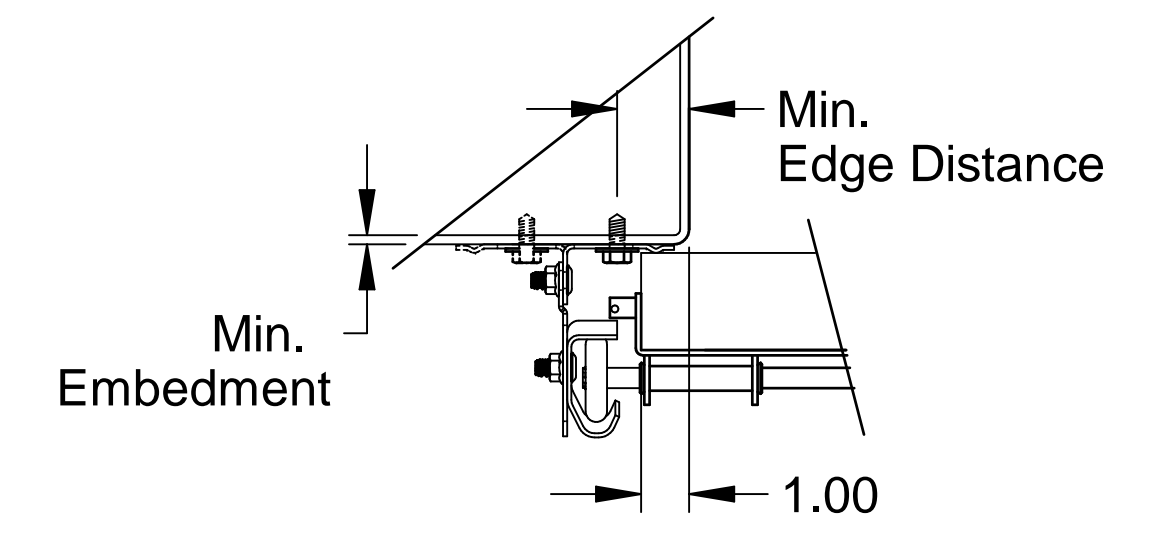

Pre-Assembled Track Assembly Attachment to 3/16" Min. Steel Jamb

2" Clip angle turned-in standard (solid)
2" Clip angle turned-out optional (dashed)
3" Clip angle available

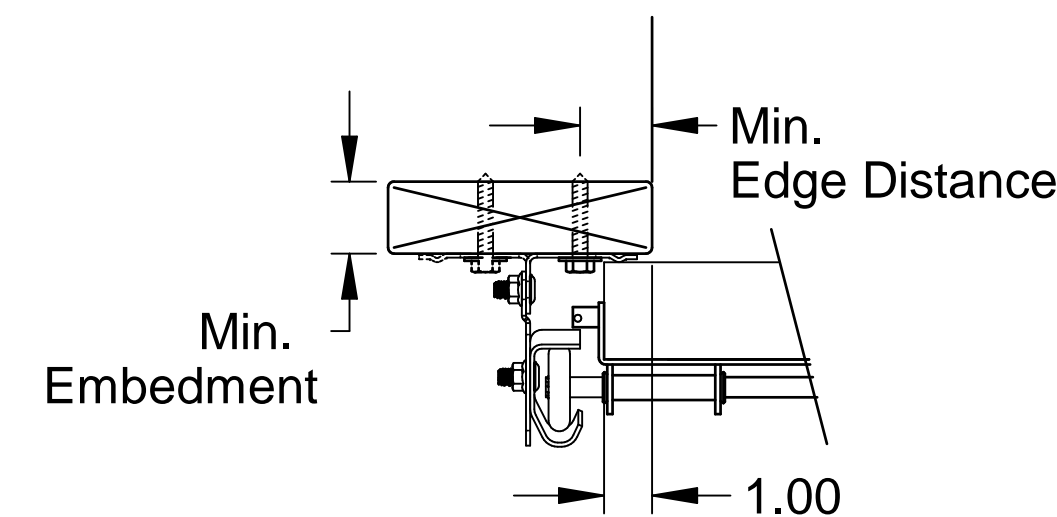

Pre-Assembled Track Assembly Attachment to Wood Jamb

2" Clip angle turned-in standard (solid)
2" Clip angle turned-out optional (dashed)
3" Clip angle available

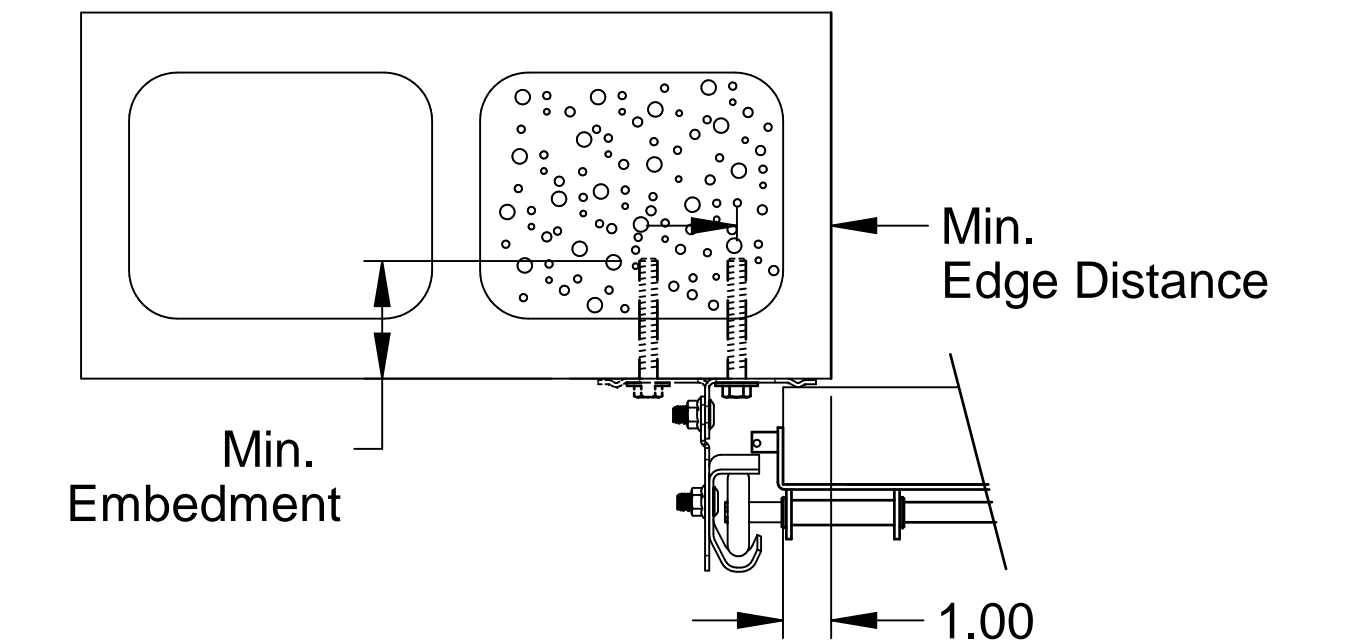

Pre-Assembled Track Assembly Attachment to Grout Filled CMU Block

2" Clip angle turned-in standard (solid)
2" Clip angle turned-out optional (dashed)
3" Clip angle available

Scale: None
Drawn by: R. Frey
Checked by: G. Wedekind
Date: 05/24/22
ECO: 8593.01



Title: Spec, Wind Load Commercial Encore	
No. P-2447	Rev A
Sheet 4	