

Section A-A

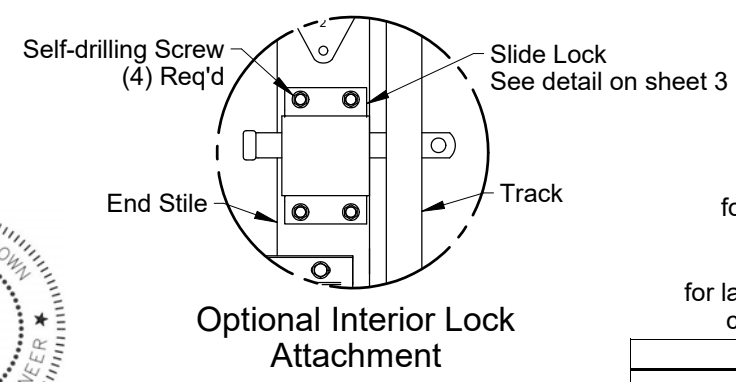

Interior Skin
.015 Thick G-40 galvanized steel with an epoxy primer and baked on polyester finish which is roll-formed with a texture embossed skin.
Exterior Skin
.015 Thick G-40 galvanized steel with an epoxy primer and baked on polyester finish which is roll-formed with a texture embossed skin.

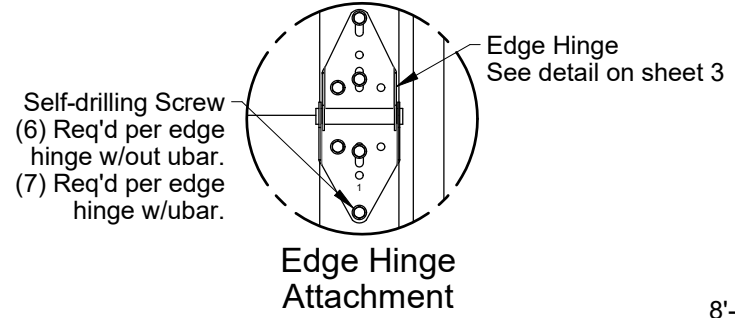
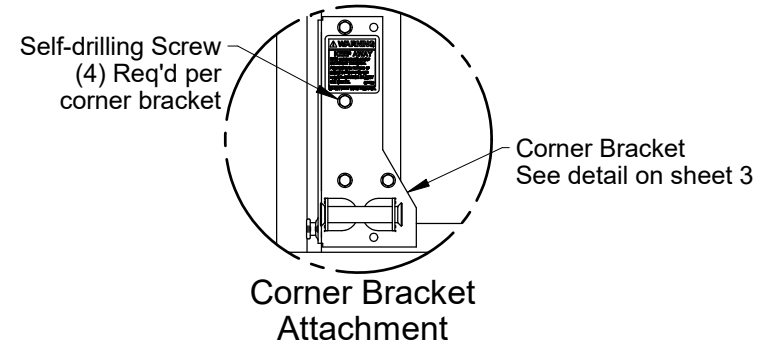
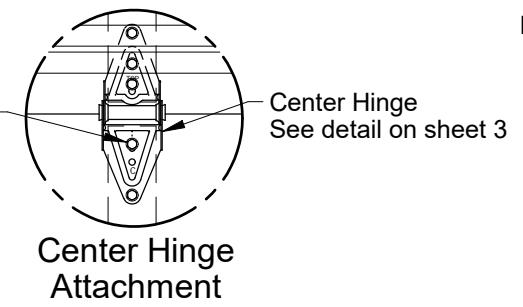
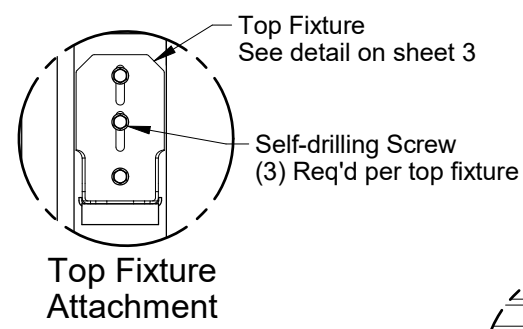
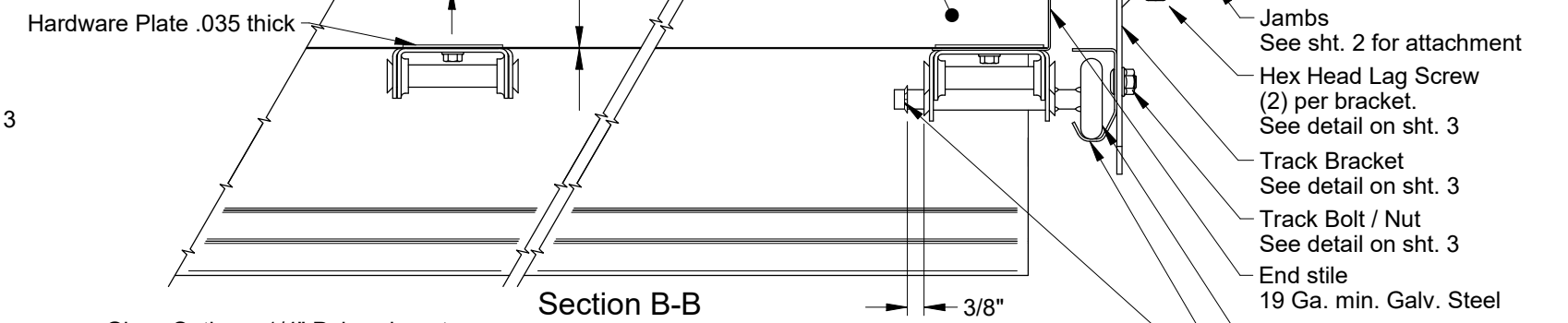

Section B-B

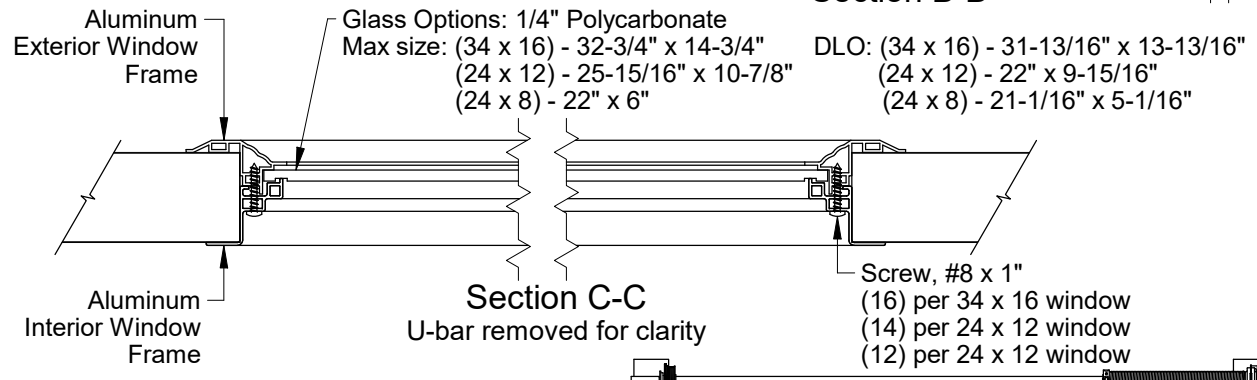

Door Height
8'-0" High shown
Other door heights available up to 18'-0" using 21" or 24" high sections

Windows (Optional)
One row maximum
34" x 16" Shown
24" x 12"
24" x 8"
Steel Reinforcement
(1) Box strut per section, (2) ubar on window section fastened to all center and end stiles using (2) self-drilling screws at each stile.

Embedded Hardware Plates
Locks required on doors not electrically operated.
Vents (Optional)
Vent openings may be located in bottom section as allowed by local code

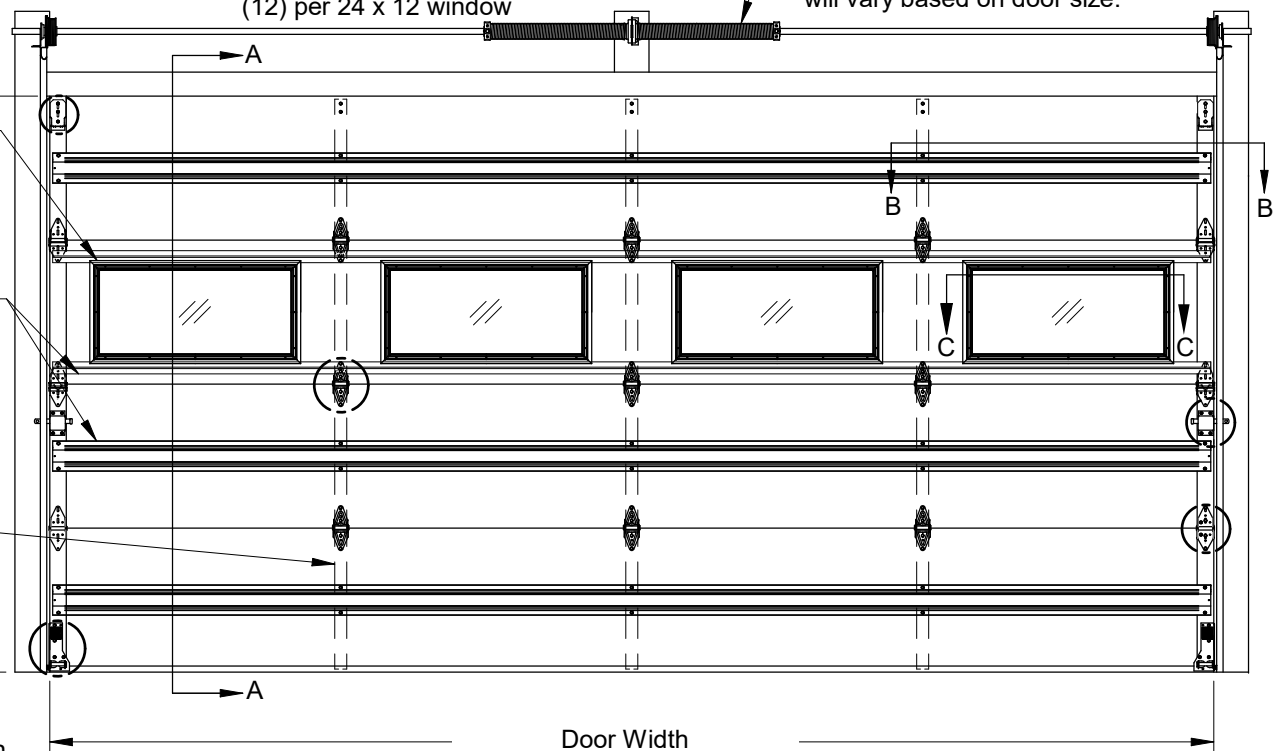

Interior Elevation
Door Width See chart for other door widths (16'-2" shown)

Doors tested per ANSI/DASMA 108 for static air pressure and ANSI/DASMA 115 for large missile impact and cyclic wind pressure

EC224 / EC200			
Maximum Door Width	Ctr. Hngs. per Sect.	Design Loads	
Up to 8'-2"	1	51.1	-59.3
9'-2"			
10'-2"	2	41.1	-46.4
12'-2"			
14'-2"	3	27.8	-33.1
16'-2"			
18'-2"	4	16.8	-18.7
20'-2"			



Scott A. Brown, P.E. Lic. No. 65940
Wendler Engineering Services, Inc.
698 Timber Creek Road, Dixon, IL 61021
FBPE CA Lic. No. 31544
Structural Adequacy for Wind Load

Printed copies of this document are not considered signed and sealed and the SHA authentication code must be verified on any electronic copies.

Scale: None	8593.03	10/04/22	Date: 10/04/22
Drawn by: R. Frey	ECO		ECO: 8593.03
Checked by: G. Wedekind			
Rev. A	Description		
	New release for production.		



Title: Spec, Wind Load EnergyCore		Rev
No. P-3406	Sheet 1 of 4	A

FL# 41569

Jamb Attachment Notes:

1. Maximum Positive Load per Jamb = $(12'-2" \times 41.1 \text{ PSF}) / 2 = 251 \text{ lbs. per foot.}$
2. Maximum Negative Load per Jamb = $(12'-2" \times -46.4 \text{ PSF}) / 2 = 283 \text{ lbs. per foot.}$
3. Design of the supporting structure shall be the sole responsibility of the building designer and shall be designed for the jamb loads listed in notes 1 and 2.
4. Alternate jamb attachments may be used if approved by a registered Professional Engineer.
5. DASMA Technical Data Sheet TDS-161 may be used for alternate jamb attachments.
6. 3/8" diameter lag screws required 1/4" pilot hole and 1-1/2" minimum required distance.
7. Masonry fasteners by others.

2x6 Attachment to Structure						
Structure Type	Fastener Type	Minimum Embedment	Minimum Edge Distance	Minimum on Center Spacing	Maximum on Center Spacing	Allowable Tension Load
2500 PSI Min. Concrete	1/4" Tapcon+ (Plus) with 1-1/8" OD Washer	2"	2.5	6"	24"	526
Southern Pine	3/8" x 3" Lag with 1-1/8" OD Washer	1.50"	1.50"	1.50"	24"	655
Spruce Pine Fir	3/8" x 3" LAG with 1-1/8" OD Washer	1.50"	1.50"	1.50"	23"	482

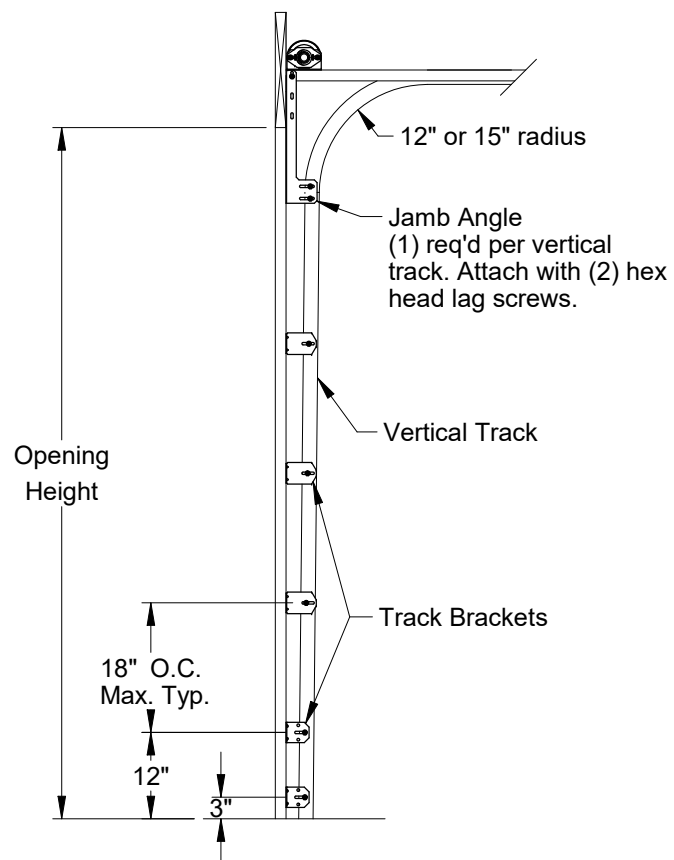
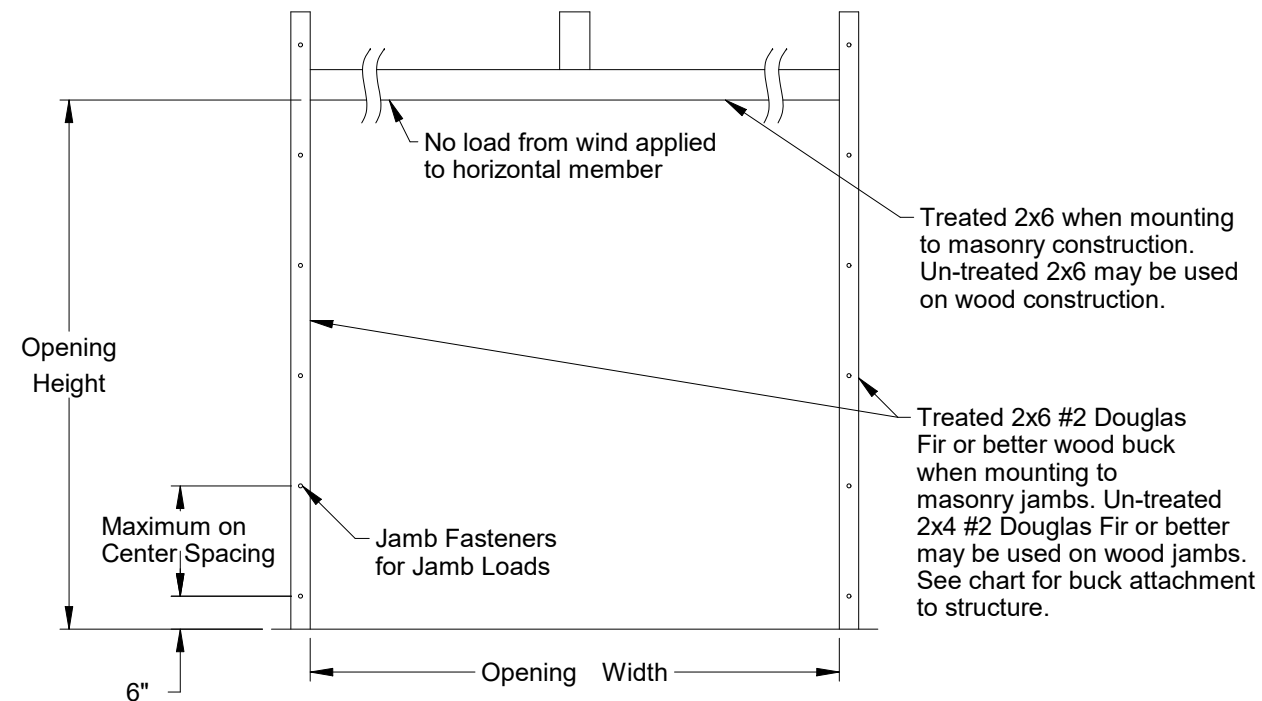

Typical Track Installation
Bracket Mount
Wood Jamba

Normal headroom track shown, low headroom, lift clearance and vertical lift track available.

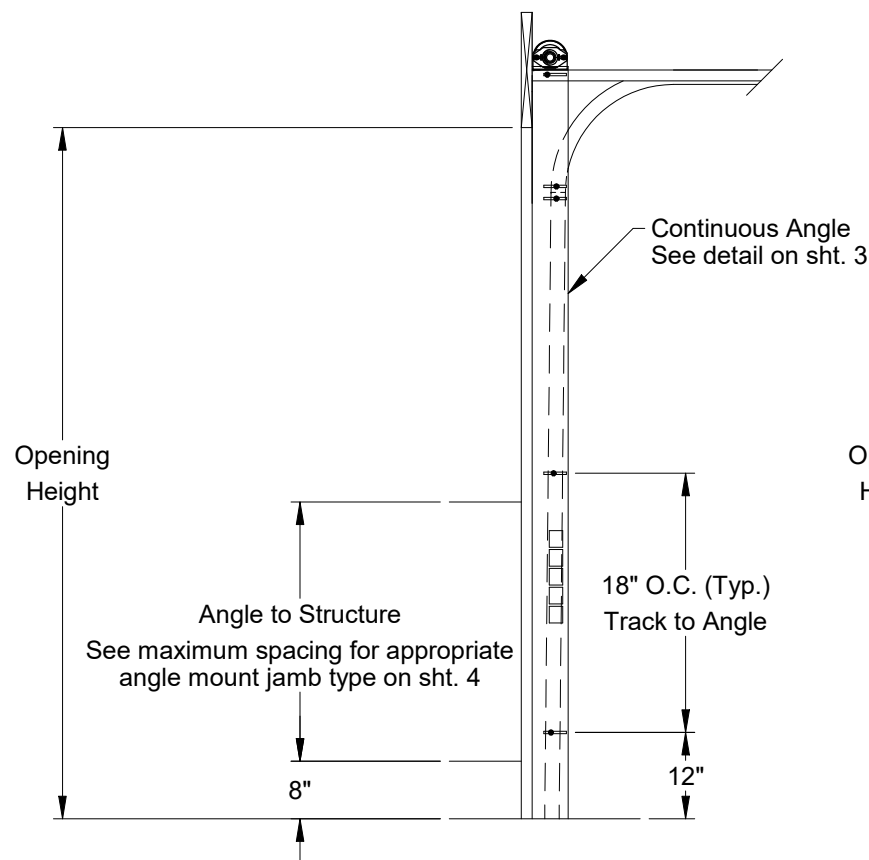

Typical Track Installation
Angle Mount
Wood, Steel or Concrete Jamba

Normal headroom track shown, low headroom, lift clearance and vertical lift track available.

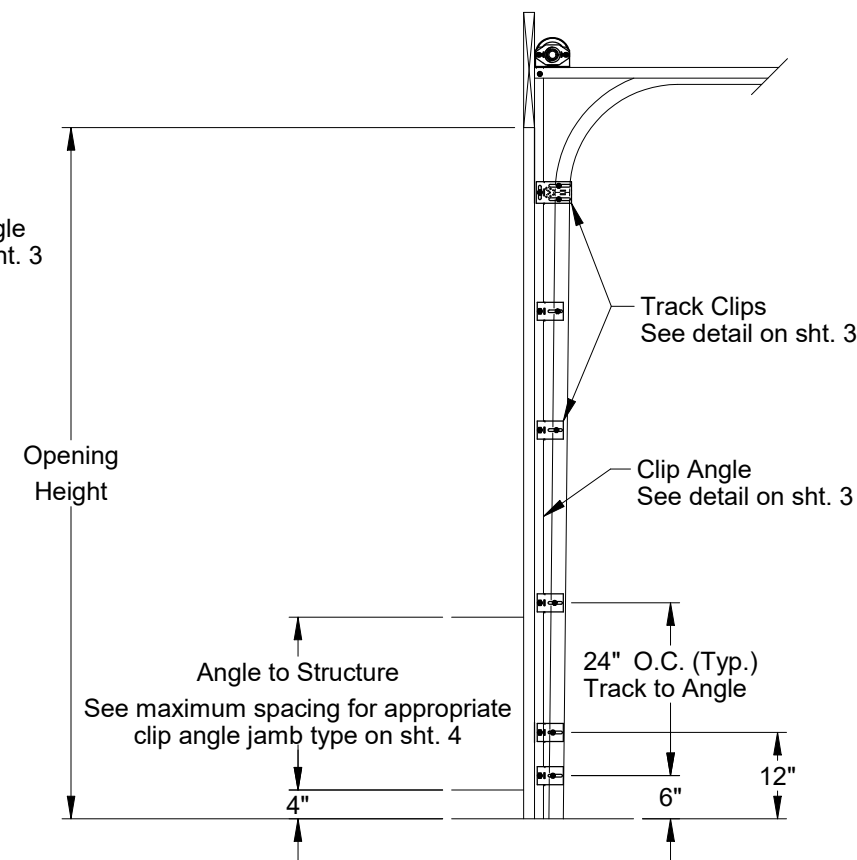

Typical Track Installation
Pre-Assembled Clip Angle
Wood, Steel or Concrete Jamba

Normal headroom track shown, lift clearance and vertical lift track available.



Scott A. Brown, P.E. Lic. No. 65940
Wendler Engineering Services, Inc.
698 Timber Creek Road, Dixon, IL 61021
FBPE CA Lic. No. 31544
Structural Adequacy for Wind Load

Scale: None	<p>1101 East River Road Dixon, IL. 61021</p>	Title: Spec, Wind Load EnergyCore	
Drawn by: R. Frey		No. P-3406	Sheet 2
Checked by: G. Wedekind			
Date: 10/04/22			
ECO: 8593.03			

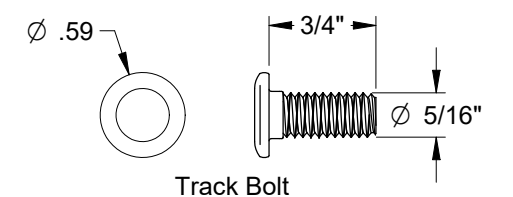
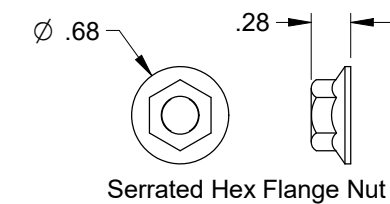
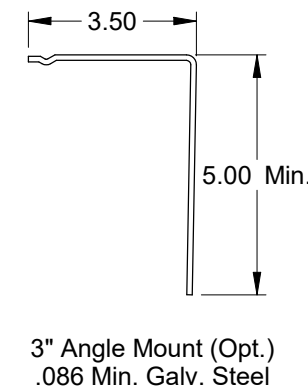
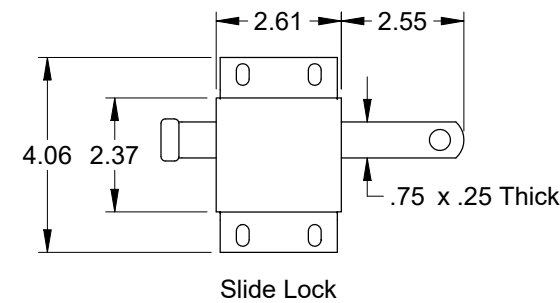
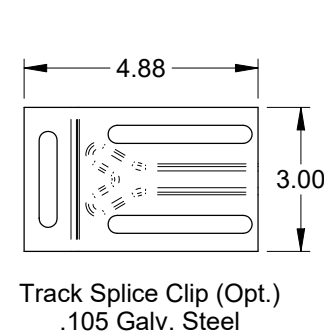
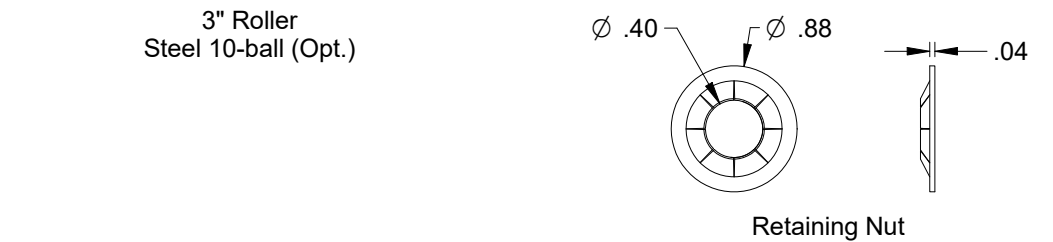
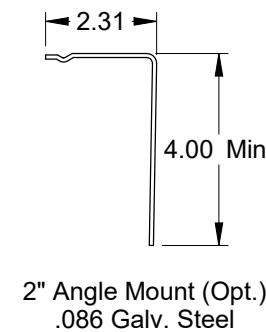
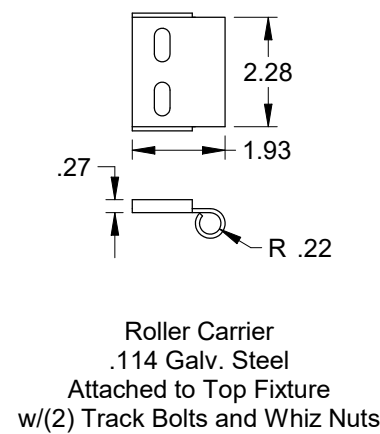
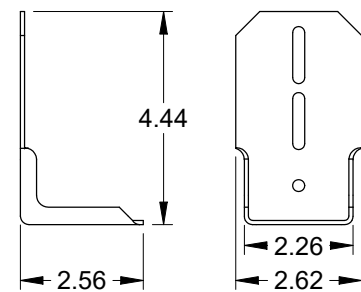
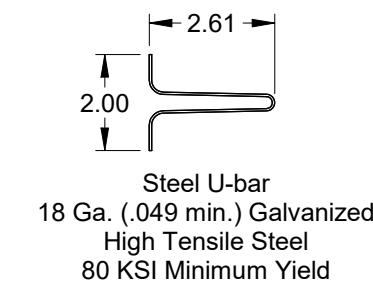
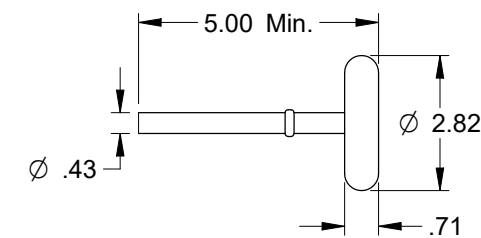
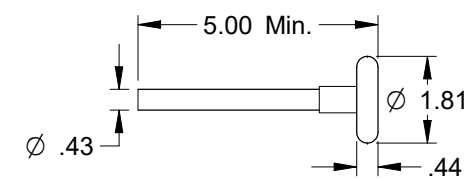
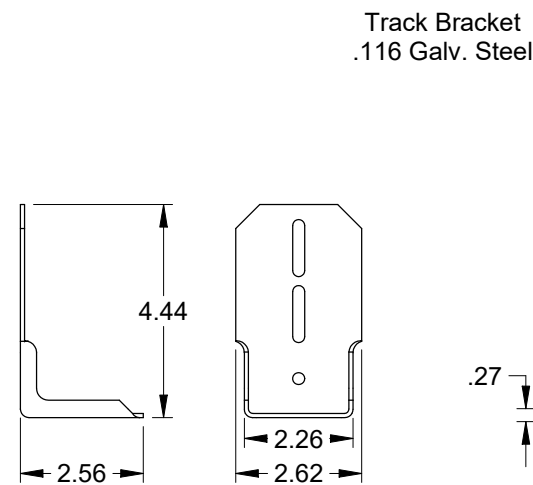
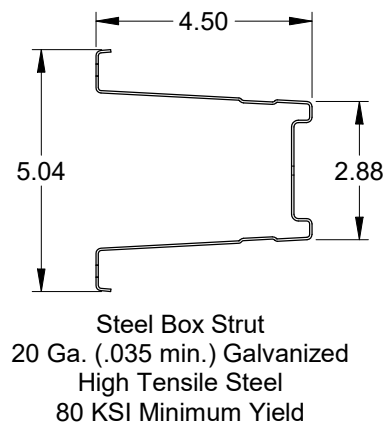
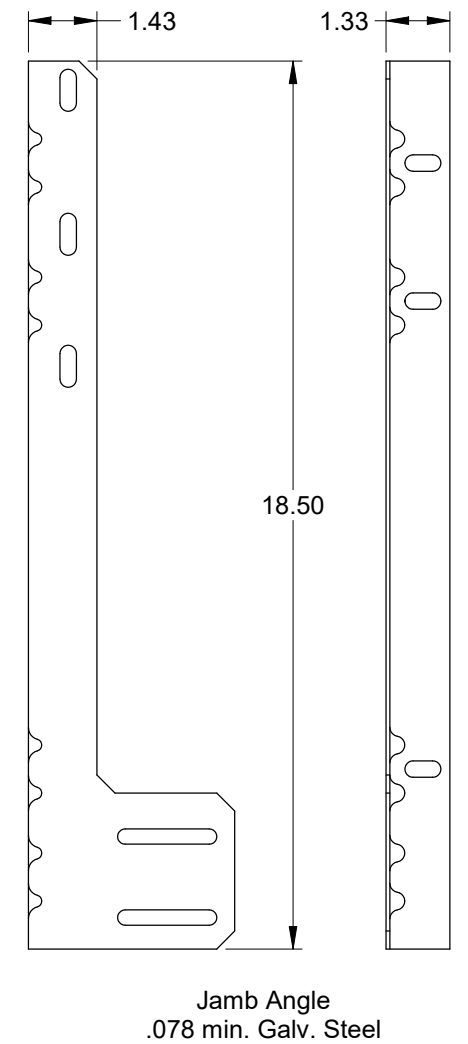
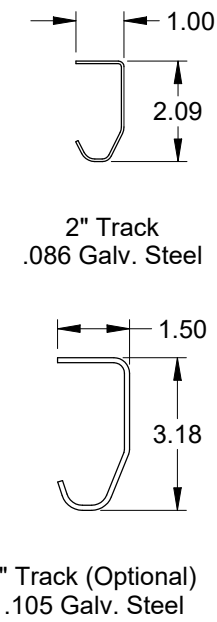
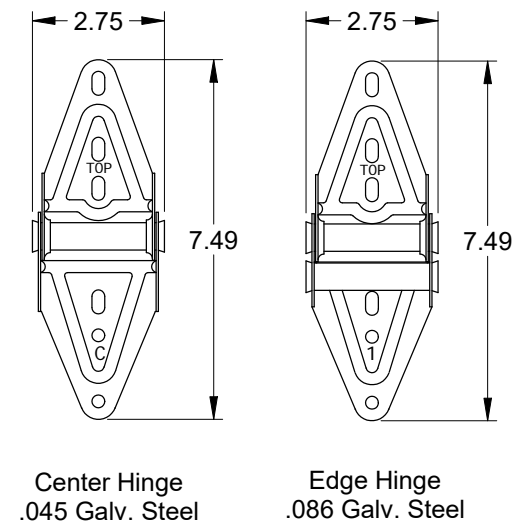
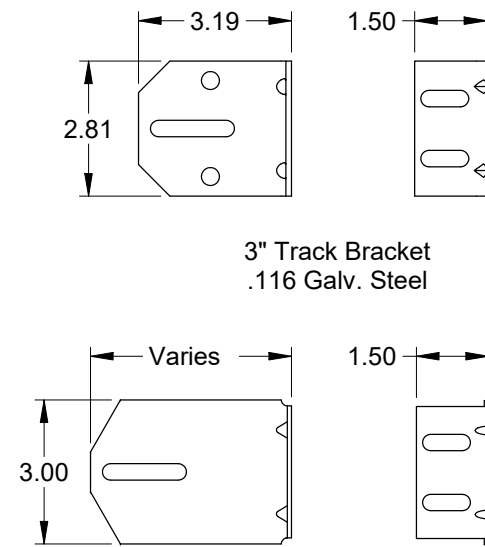
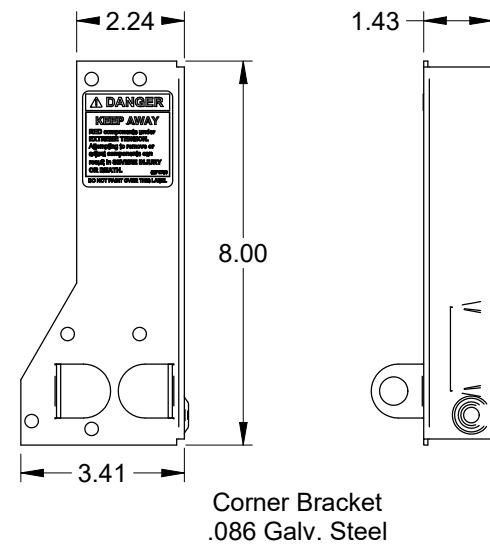

Scott A. Brown, P.E. Lic. No. 65940
Wendler Engineering Services, Inc.
698 Timber Creek Road, Dixon, IL 61021
FBPE CA Lic. No. 31544
Structural Adequacy for Wind Load

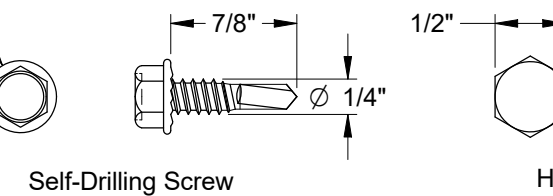
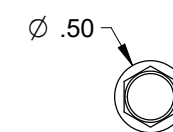
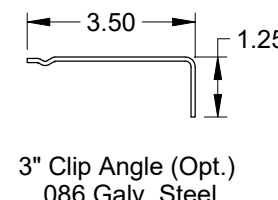
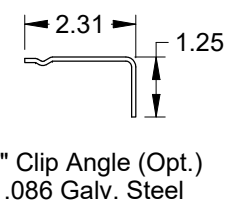
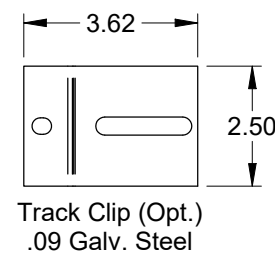

Printed copies of this document are not considered signed and sealed and the SHA authentication code must be verified on any electronic copies.

All parts shown are for illustration purposes only. The actual product may include equivalent parts due to availability.

Scale: None
Drawn by: R. Frey
Checked by: G. Wedekind
Date: 10/04/22
ECO: 8593.03



Title: Spec, Wind Load EnergyCore		
No. P-3406	Sheet 3	Rev A

Angle Mount					
Jamb Type	Fastener Type	Minimum Embedment (in.)	Minimum Edge Distance (in.)	Maximum on Center Spacing (in.)	Allowable Tension Load (lbs.)
2500 PSI Min. Concrete	3/8" ITW Trubolt	2-1/2"	2-1/2"	36"	893
	1/4" Tapcon+ (Plus) with 1-1/8" OD Washer	2"	1-5/8"	18"	687
	1/4" x 2-5/8" Screw-Bolt+ with 9/16" OD Washer	2-1/2"	1-1/2"	18"	651
Steel	5/16" x 1" SAE J78, Min. AISI 1022 with 5/16" Washer	3/16"	1-1/2"	36"	971
Wood	5/16" x 1-3/4" Lag with 5/16" Washer	1-1/2"	1-1/2"	12"	352
Grout Filled CMU Block	3/8" Simpson Titen HD	2-3/4"	4"	18"	480

Alternate fasteners may be used if approved by a registered Professional Engineer.

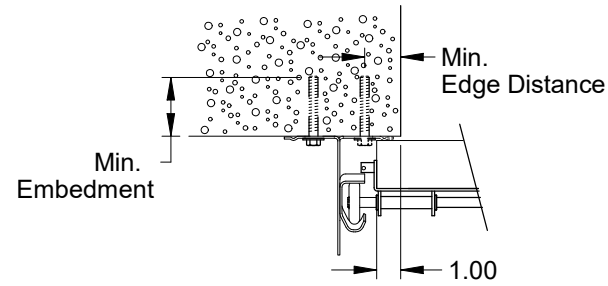

Track Assembly Attachment to 2500 PSI Min. Concrete
 2" Angle mount turned-out standard (solid)
 2" Angle mount turned-in optional (dashed)
 3" Angle mount available

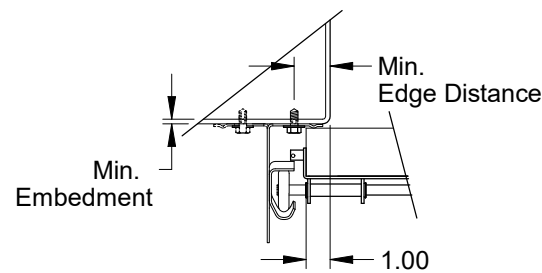

Track Assembly Attachment to 3/16" Min. Steel Jamb
 2" Angle mount turned-out standard (solid)
 2" Angle mount turned-in optional (dashed)
 3" Angle mount available

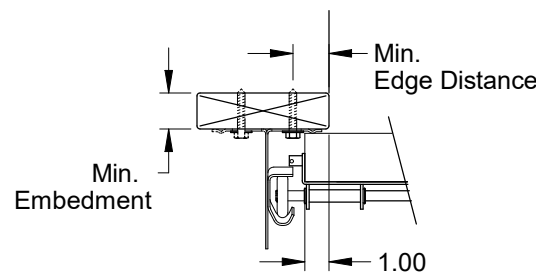

Track Assembly Attachment to Wood Jamb
 2" Angle mount turned-out standard (solid)
 2" Angle mount turned-in optional (dashed)
 3" Angle mount available

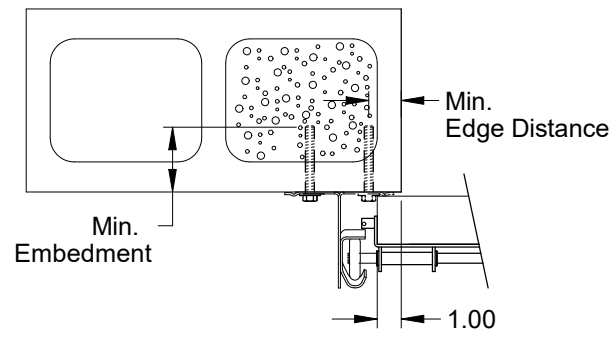

Track Assembly Attachment to Grout Filled CMU Block
 2" Angle mount turned-out standard (solid)
 2" Angle mount turned-in optional (dashed)
 3" Angle mount available



Scott A. Brown, P.E. Lic. No. 65940
 Wender Engineering Services, Inc.
 698 Timber Creek Road, Dixon, IL 61021
 FBPE CA Lic. No. 31544
 Structural Adequacy for Wind Load

Pre-Assembled Clip Angle					
Jamb Type	Fastener Type	Minimum Embedment (in.)	Minimum Edge Distance (in.)	Maximum on Center Spacing (in.)	Allowable Tension Load (Lbs.)
2500 PSI Min. Concrete	3/8" ITW Trubolt	2-1/2"	2-1/2"	24"	893
	1/4" Tapcon+ (Plus) with 1-1/8" OD Washer	2"	1-5/8"	24"	687
	1/4" x 2-5/8" Screw-Bolt+ with 9/16" OD Washer	2-1/2"	1-1/2"	24"	651
Steel	5/16" x 1" SAE J78, Min. AISI 1022 with 5/16" Washer	3/16"	1-1/2"	24"	971
Wood	5/16" x 1-3/4" Lag with 5/16" Washer	1-1/2"	1-1/2"	*12"	352
Grout Filled CMU Block	3/8" Simpson Titen HD	2-3/4"	4"	*12"	480

* Field drilling req'd.

Alternate fasteners may be used if approved by a registered Professional Engineer.

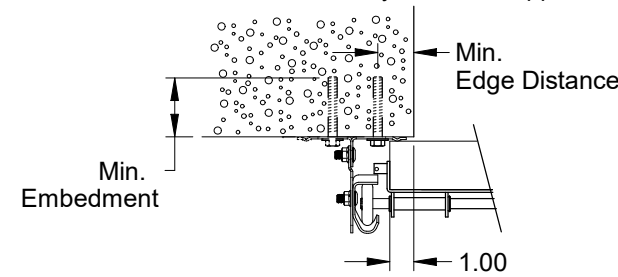

Pre-Assembled Track Assembly Attachment to 2500 PSI Min. Concrete
 2" Clip angle turned-in standard (solid)
 2" Clip angle turned-out optional (dashed)
 3" Clip angle available

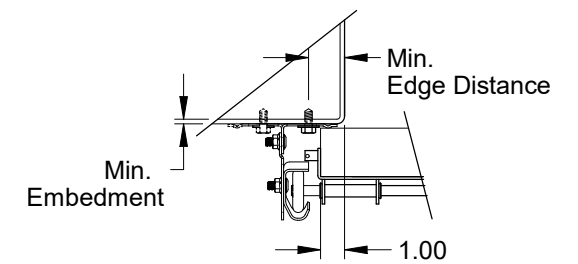

Pre-Assembled Track Assembly Attachment to 3/16" Min. Steel Jamb
 2" Clip angle turned-in standard (solid)
 2" Clip angle turned-out optional (dashed)
 3" Clip angle available

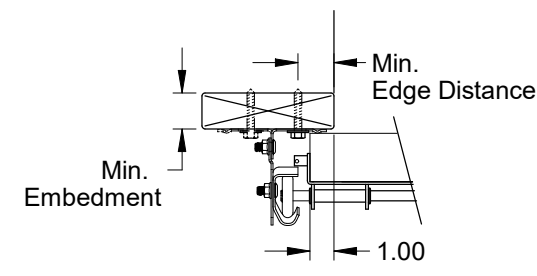

Pre-Assembled Track Assembly Attachment to Wood Jamb
 2" Clip angle turned-in standard (solid)
 2" Clip angle turned-out optional (dashed)
 3" Clip angle available

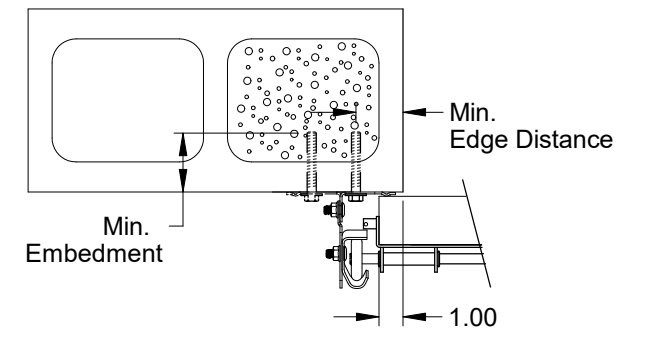

Pre-Assembled Track Assembly Attachment to Grout Filled CMU Block
 2" Clip angle turned-in standard (solid)
 2" Clip angle turned-out optional (dashed)
 3" Clip angle available

Scale: None
Drawn by: R. Frey
Checked by: G. Wedekind
Date: 10/04/22
ECO: 8593.03



Title: Spec, Wind Load EnergyCore	
No. P-3406	Rev A
Sheet 4	