

REVISIONS			
REV	DESCRIPTION	DATE	APPROVED

NOTES:

1. THE PRODUCT SHOWN HEREIN IS DESIGNED AND MANUFACTURED TO COMPLY WITH REQUIREMENTS OF THE FLORIDA BUILDING CODE INCLUDING THE HVHZ.
2. WOOD FRAMING AND MASONRY OPENING TO BE DESIGNED AND ANCHORED TO PROPERLY TRANSFER ALL LOADS TO STRUCTURE. FRAMING AND MASONRY OPENING IS THE RESPONSIBILITY OF THE ARCHITECT OR ENGINEER OF RECORD.
3. WHERE SHIM OR BUCK THICKNESS IS LESS THAN 1-1/2" UNITS MUST BE ANCHORED THROUGH THE FRAME IN ACCORDANCE WITH MANUFACTURER'S PUBLISHED INSTALLATION INSTRUCTIONS. ANCHORS SHALL BE SECURELY FASTENED DIRECTLY INTO MASONRY, CONCRETE OR OTHER STRUCTURAL SUBSTRATE MATERIAL.
4. WHERE WOOD BUCK THICKNESS IS 1-1/2" OR GREATER, BUCK SHALL BE SECURELY FASTENED TO MASONRY, CONCRETE OR OTHER STRUCTURAL SUBSTRATE. UNITS MAY BE ANCHORED THROUGH FRAME TO SECURED WOOD BUCK IN ACCORDANCE WITH MANUFACTURER'S PUBLISHED INSTALLATION INSTRUCTIONS.
5. WHERE 1X BUCK IS NOT USED DISSIMILAR MATERIALS MUST BE SEPARATED WITH APPROVED COATING OR MEMBRANE. SELECTION OF COATING OR MEMBRANE IS THE RESPONSIBILITY OF THE ARCHITECT OR ENGINEER OF RECORD.
6. BUCKS SHALL EXTEND BEYOND UNIT FRAME INTERIOR FACE SO THAT FULL FRAME SUPPORT IS PROVIDED.
7. SHIM AS NEEDED. AT EACH ANCHOR LOCATION WITH LOAD BEARING SHIM. SHIM WHERE SPACE OF 1/16" OR GREATER OCCURS. MAXIMUM ALLOWABLE SHIM STACK TO BE 1/4".
8. SHIMS SHALL BE LOCATED, APPLIED AND MADE FROM MATERIALS AND THICKNESS CAPABLE OF SUSTAINING APPLICABLE LOADS.
9. WIND LOAD DURATION FACTOR Cd=1.6 WAS USED FOR WOOD ANCHOR CALCULATIONS.
10. FRAME MATERIAL: ALUMINUM 6063-T5.
11. UNITS MUST BE GLAZED PER ASTM E1300, WITH SAFETY GLAZING.
12. APPROVED IMPACT PROTECTIVE SYSTEM IS REQUIRED FOR THIS PRODUCT IN WIND BORNE DEBRIS REGIONS.
13. FOR ANCHORING THROUGH FRAME INTO WOOD FRAMING OR 2X BUCK USE #10 WOOD SCREWS WITH SUFFICIENT LENGTH TO ACHIEVE A 1 1/4" MINIMUM EMBEDMENT INTO SUBSTRATE. LOCATE ANCHORS AS SHOWN IN ELEVATIONS AND INSTALLATION DETAILS.
14. FOR ANCHORING THROUGH FRAME INTO MASONRY/CONCRETE USE 3/16" TAPCONS WITH SUFFICIENT LENGTH TO ACHIEVE A 1 3/4" MINIMUM EMBEDMENT INTO SUBSTRATE WITH 2" MINIMUM EDGE DISTANCE. LOCATE ANCHORS AS SHOWN IN ELEVATIONS AND INSTALLATION DETAILS.
15. FOR ANCHORING THROUGH FRAME INTO METAL STRUCTURE USE #10 SMS OR SELF DRILLING SCREWS WITH SUFFICIENT LENGTH TO ACHIEVE 3 THREADS MINIMUM BEYOND STRUCTURE INTERIOR WALL. LOCATE ANCHORS AS SHOWN IN ELEVATIONS AND INSTALLATION DETAILS.
16. ALL FASTENERS TO BE CORROSION RESISTANT.
17. INSTALLATION ANCHORS SHALL BE INSTALLED IN ACCORDANCE WITH ANCHOR MANUFACTURER'S INSTALLATION INSTRUCTIONS AND ANCHORS SHALL NOT BE USED IN SUBSTRATES WITH STRENGTHS LESS THAN THE MINIMUM STRENGTH SPECIFIED BELOW:
 - A. WOOD: MINIMUM SPECIFIC GRAVITY OF G=0.42
 - B. CONCRETE: MINIMUM COMPRESSIVE STRENGTH OF 2,000 PSI.
 - C. MASONRY: GROUT/FILLED BLOCK PER ASTM C90 WITH Fm=2,000PSI MINIMUM.
 - D. METAL STRUCTURE: STEEL 18GA (.048") FY=33KSI/FU=52KSI OR ALUMINUM 6063-T5 FU=30KSI 1/8" THICK MINIMUM

TABLE OF CONTENTS	
SHEET NO.	DESCRIPTION
1	NOTES
2	ELEVATION AND GLAZING DETAILS
3 - 6	INSTALLATION DETAILS
7	COMPONENTS

E6 GLOBAL IPA, LLC. 12-1394, 369 GANGNAM-DAERO, SEOCHO-GU SEOUL 06621, SOUTH KOREA		
AZ57-HWF2 TWIN CORE ALUMINUM BIFOLD DOOR NON-IMPACT NOTES		
DRAWN: R.L.	DWG NO. 08-03852	REV -
SCALE NTS	DATE 11/18/2022	SHEET 1 OF 7
L. ROBERTO LOMAS P.E. 400 S. PALM AVE, INDIAN LANTIC, FL 32903 434-688-0609 rllomas@rlomaspe.com		

SIGNED: 12/19/2022

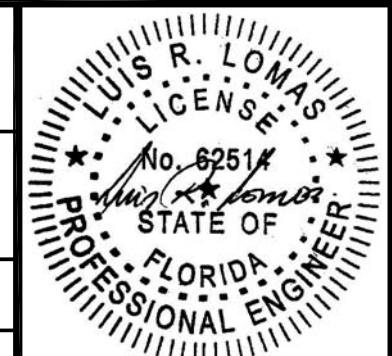

Luis R. Lomas P.E.
FL No.: 62514

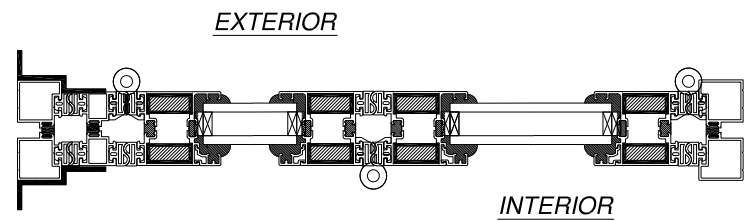

REVISIONS			
REV	DESCRIPTION	DATE	APPROVED

- NOTES:
 1. PANEL SIZE: 36" X 80"
 2. D.L.O. SIZE: 32 3/8" X 76 3/8"

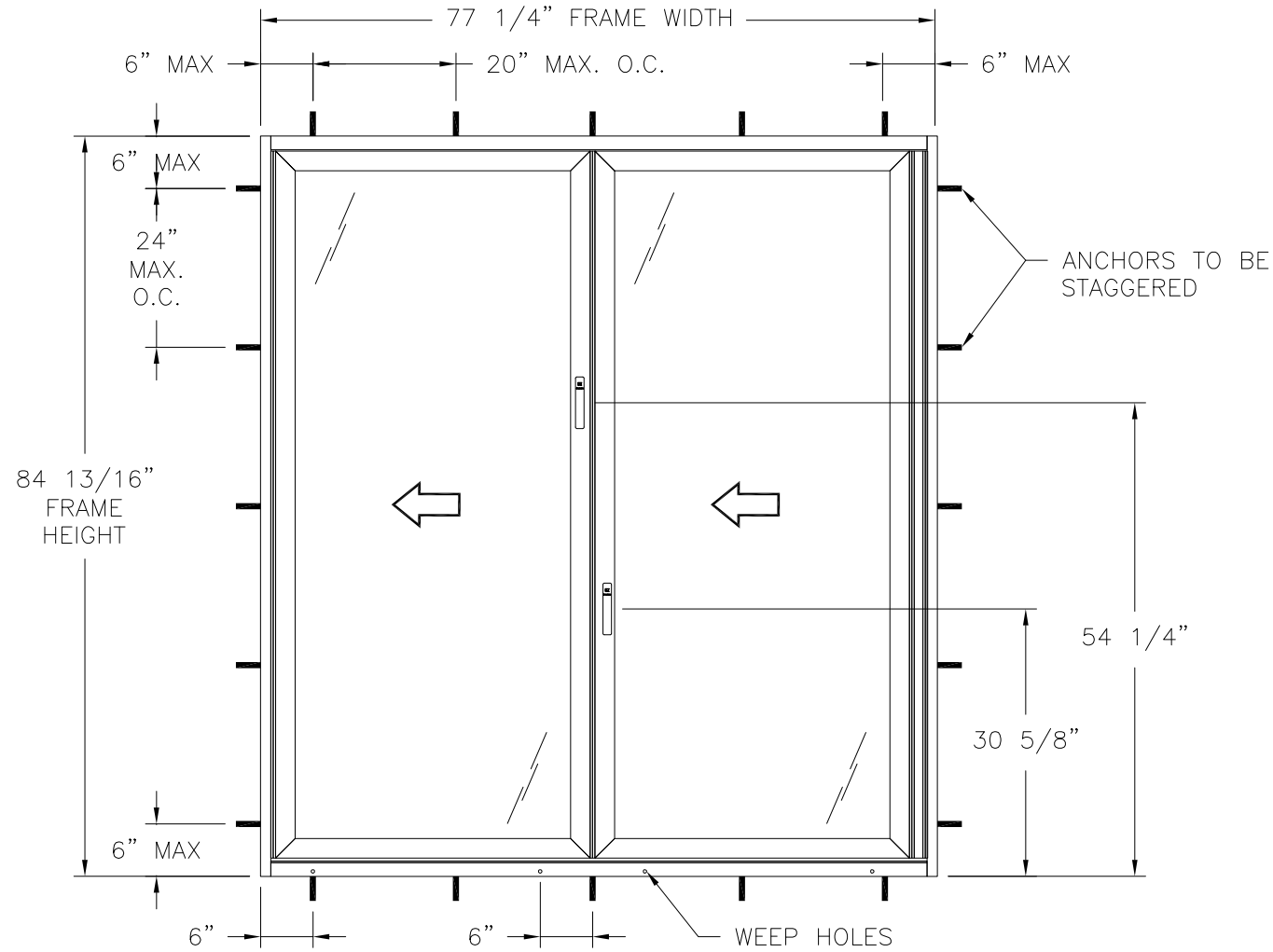

AZ57-HWF2 TWIN CORE ALUMINUM BIFOLD DOOR
 INTERIOR VIEW

DESIGN PRESSURE RATING	IMPACT RATING
±70.0PSF	NONE

HARDWARE SCHEDULE

A.	HINGE WITH ROLLER, 4" FROM EACH END OF THE STILES ON PANELS
B.	MULTI-POINT LOCK SHOOT BOLTS AT HEAD AND SILL OF EACH PANEL AND AT HANDLE LOCATION
C.	ALUMINUM CLIP RUNNING FULL LENGTH OF JAMB
D.	L-BRACKET (ALUMINUM 6063-T5) AT FRAME JAMB
E.	HANDLE (ZINC) AT PANEL STILE
F.	ALUMINUM 6063-T5 PANEL REINFORCEMENT (TWIN CORE) AT TOP, BOTTOM RAIL AND STILES
G.	(2) ALUMINUM REINFORCEMENT BAR ON EACH RAIL AND STILE

E6 GLOBAL IPA, LLC.
 12-1394, 369 GANGNAM-DAERO, SEOCHO-GU
 SEOUL 06621, SOUTH KOREA

AZ57-HWF2 TWIN CORE ALUMINUM BIFOLD DOOR
 NON-IMPACT
 ELEVATION

DRAWN: R.L.	DWG NO. 08-03852	REV -
SCALE NTS	DATE 11/18/2022	SHEET 2 OF 7

L. ROBERTO LOMAS P.E.
 400 S. PALM AVE, INDIALANTIC, FL 32903
 434-688-0609 rllomas@rlomaspe.com

SIGNED: 12/19/2022

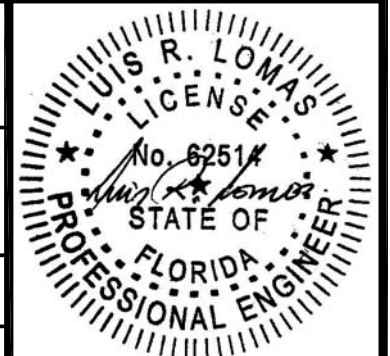

Luis R. Lomas P.E.
 FL No.: 62514

REVISIONS			
REV	DESCRIPTION	DATE	APPROVED

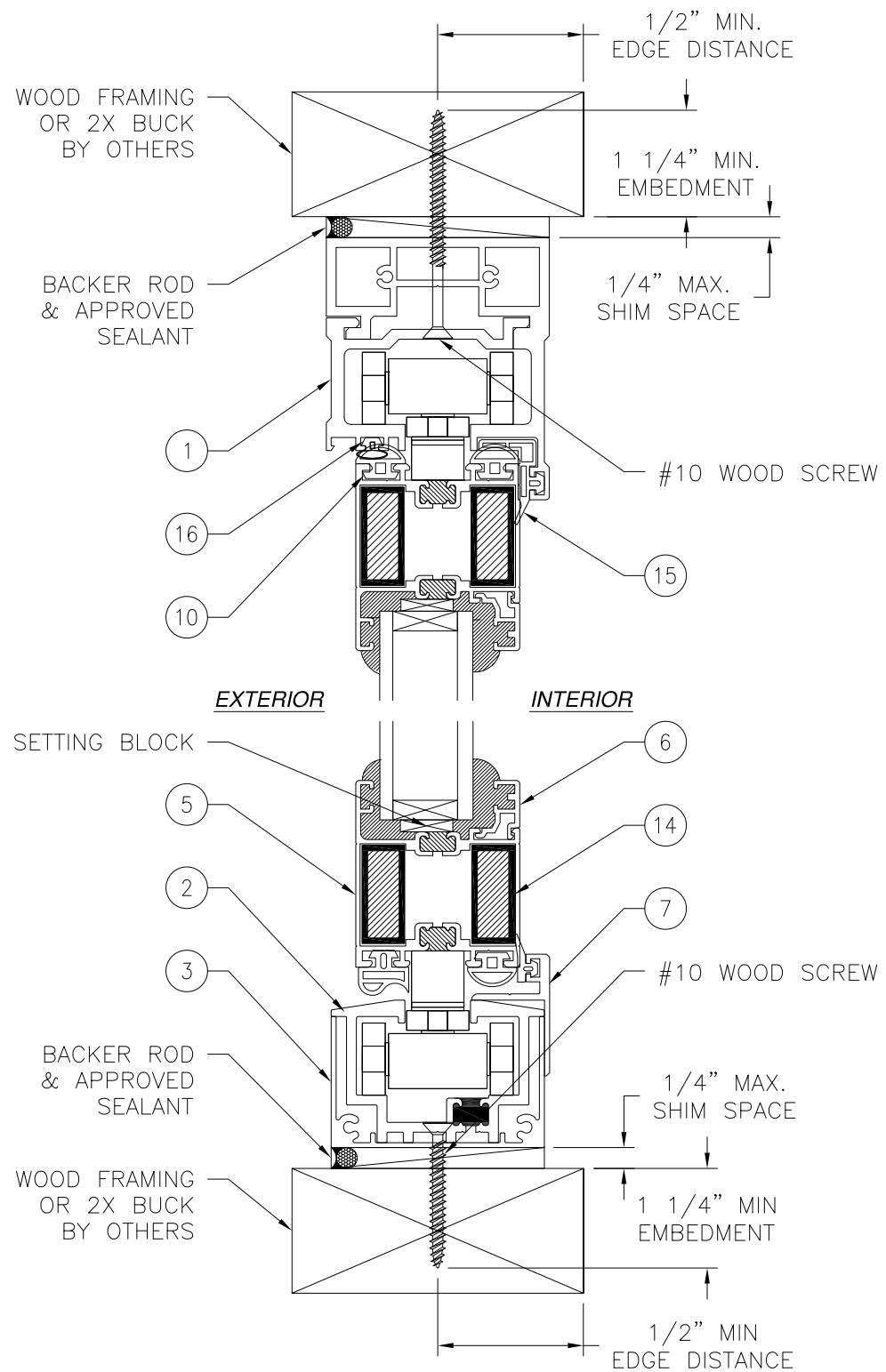

VERTICAL CROSS SECTION
WOOD FRAMING OR 2X BUCK INSTALLATION

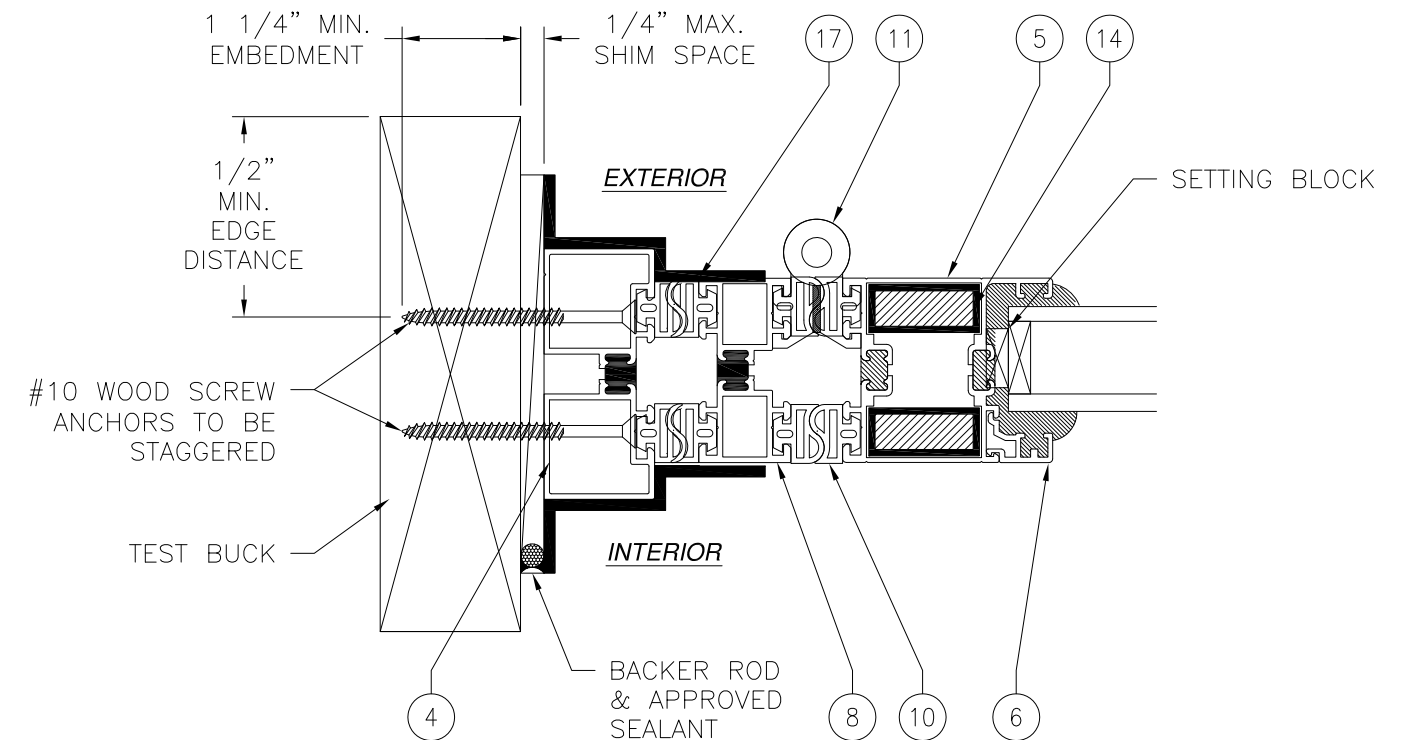

JAMB INSTALLATION DETAIL
WOOD FRAMING OR 2X BUCK INSTALLATION

- NOTES:**
1. INTERIOR AND EXTERIOR FINISHES, BY OTHERS, NOT SHOWN FOR CLARITY.
 2. PERIMETER AND JOINT SEALANT BY OTHERS TO BE DESIGNED IN ACCORDANCE WITH ASTM E2112

SIGNED: 12/19/2022

E6 GLOBAL IPA, LLC. 12-1394, 369 GANGNAM-DAERO, SEOCHO-GU SEOUL 06621, SOUTH KOREA		
AZ57-HWF2 TWIN CORE ALUMINUM BIFOLD DOOR NON-IMPACT INSTALLATION DETAILS		
DRAWN: R.L.	DWG NO. 08-03852	REV -
SCALE NTS	DATE 11/18/2022	SHEET 3 OF 7
L. ROBERTO LOMAS P.E. 400 S. PALM AVE, INDIALANTIC, FL 32903 434-688-0609 rllomas@rlomaspe.com		

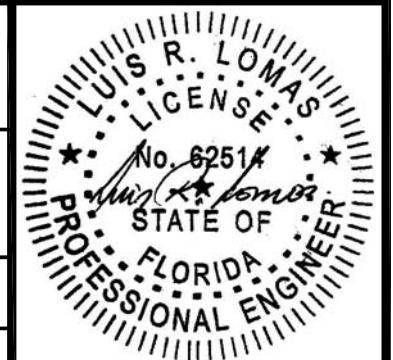

Luis R. Lomas P.E.
FL No.: 62514

REVISIONS			
REV	DESCRIPTION	DATE	APPROVED

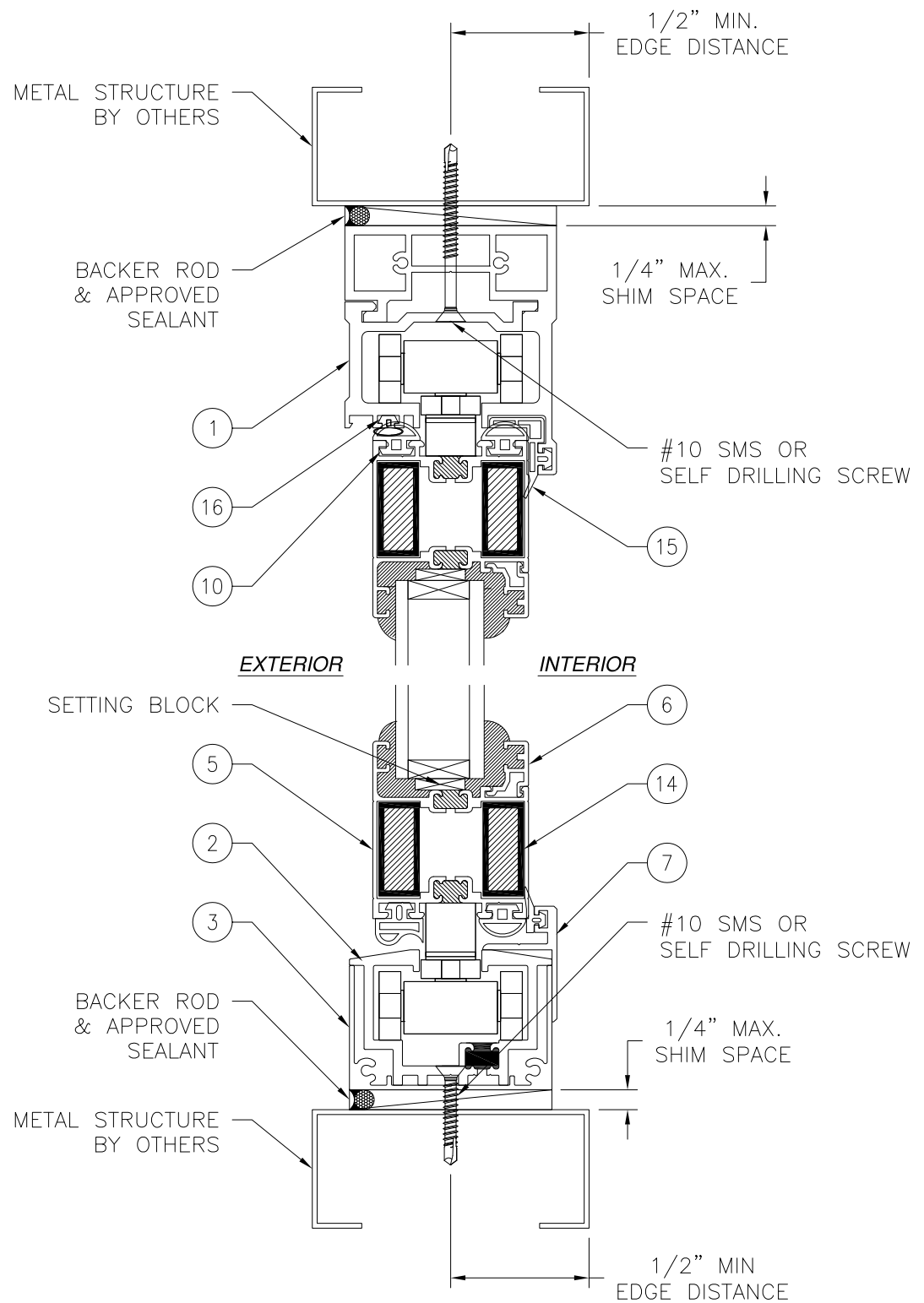

VERTICAL CROSS SECTION
METAL STRUCTURE INSTALLATION

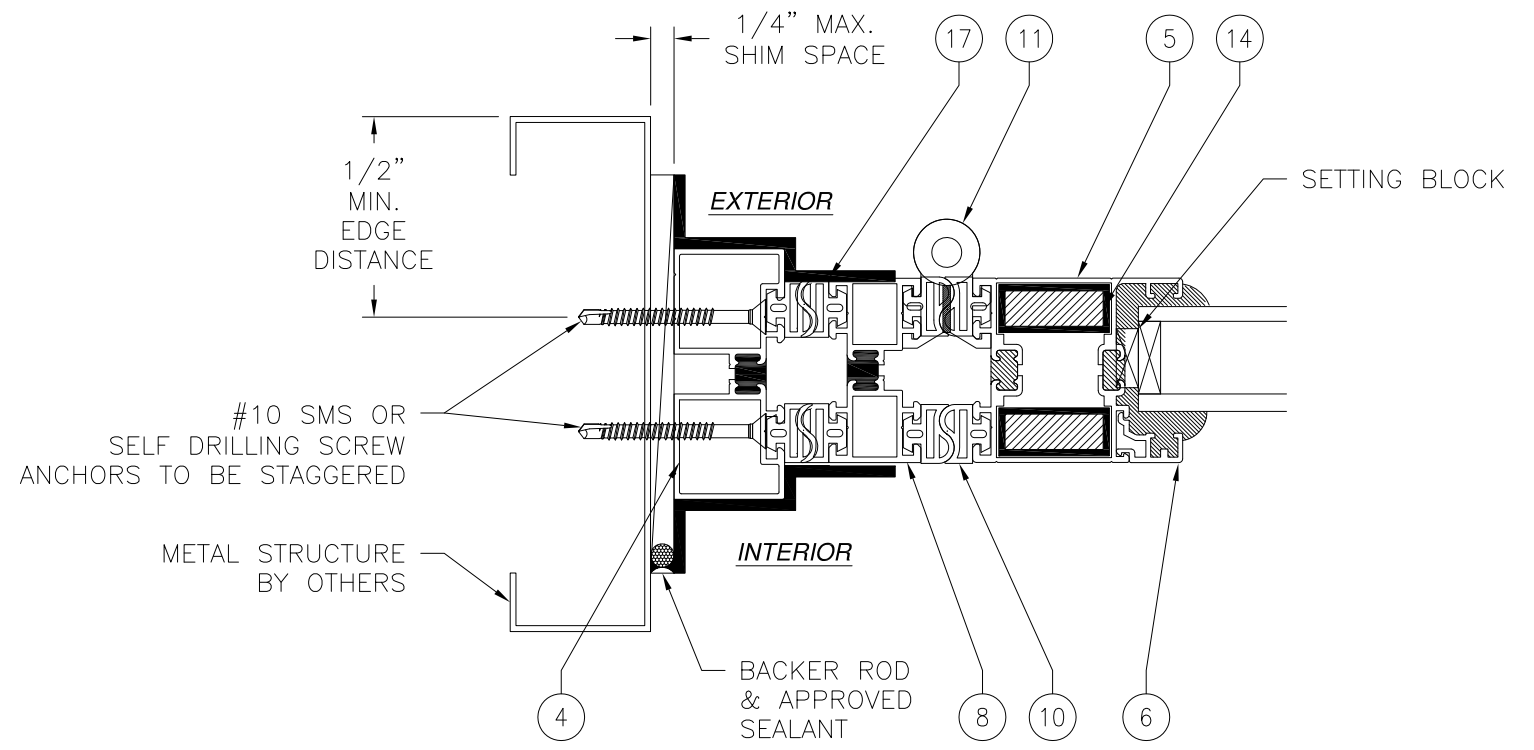

JAMB INSTALLATION DETAIL
METAL STRUCTURE INSTALLATION

- NOTES:**
1. INTERIOR AND EXTERIOR FINISHES, BY OTHERS, NOT SHOWN FOR CLARITY.
 2. PERIMETER AND JOINT SEALANT BY OTHERS TO BE DESIGNED IN ACCORDANCE WITH ASTM E2112

SIGNED: 12/19/2022

E6 GLOBAL IPA, LLC. 12-1394, 369 GANGNAM-DAERO, SEOCHO-GU SEOUL 06621, SOUTH KOREA		
AZ57-HWF2 TWIN CORE ALUMINUM BIFOLD DOOR NON-IMPACT INSTALLATION DETAILS		
DRAWN: R.L.	DWG NO. 08-03852	REV -
SCALE NTS	DATE 11/18/2022	SHEET 4 OF 7
L. ROBERTO LOMAS P.E. 400 S. PALM AVE, INDIALANTIC, FL 32903 434-688-0609 rllomas@rlomaspe.com		



Luis R. Lomas P.E.
FL No.: 62514

REVISIONS			
REV	DESCRIPTION	DATE	APPROVED

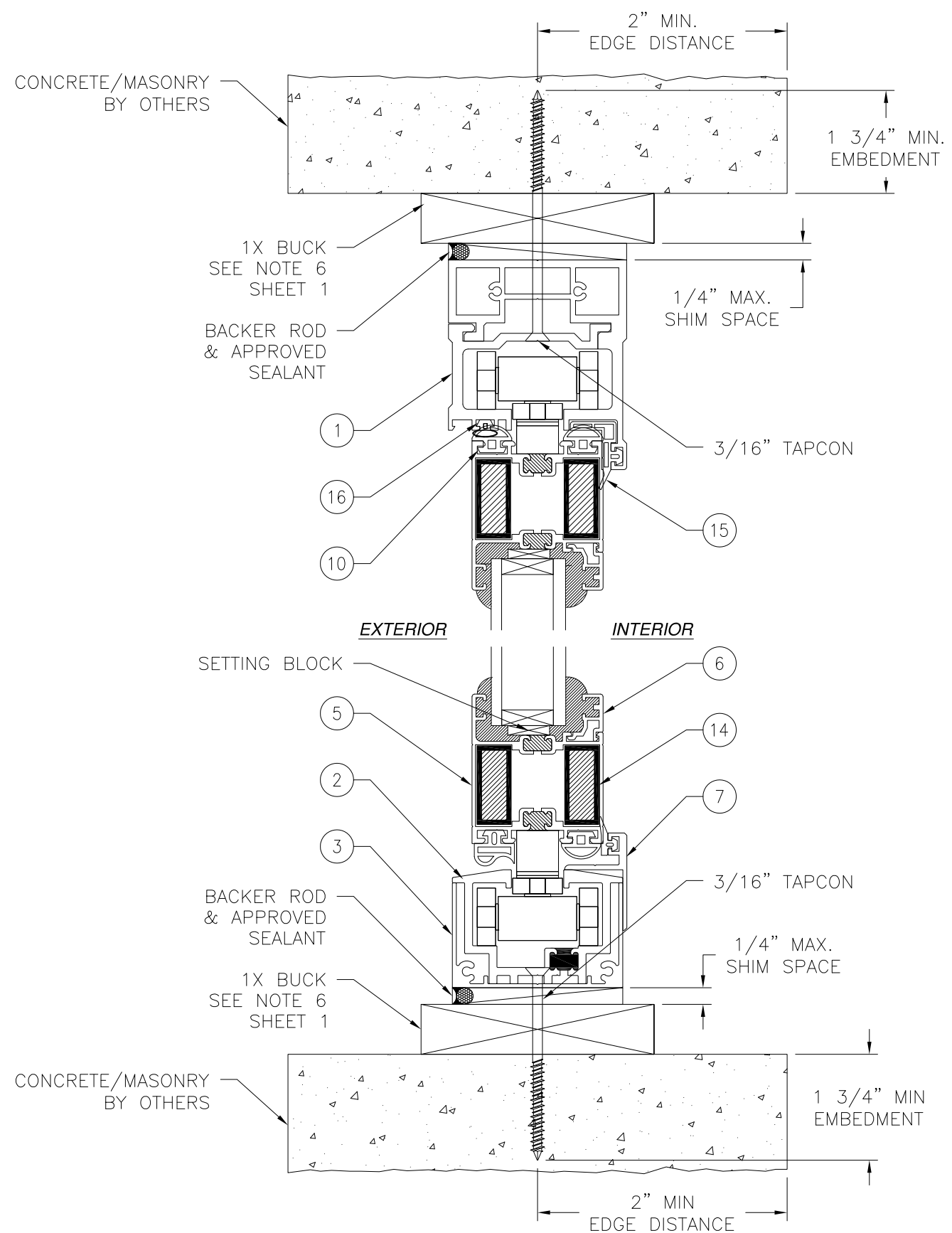

VERTICAL CROSS SECTION
CONCRETE/MASONRY W/1X BUCK INSTALLATION

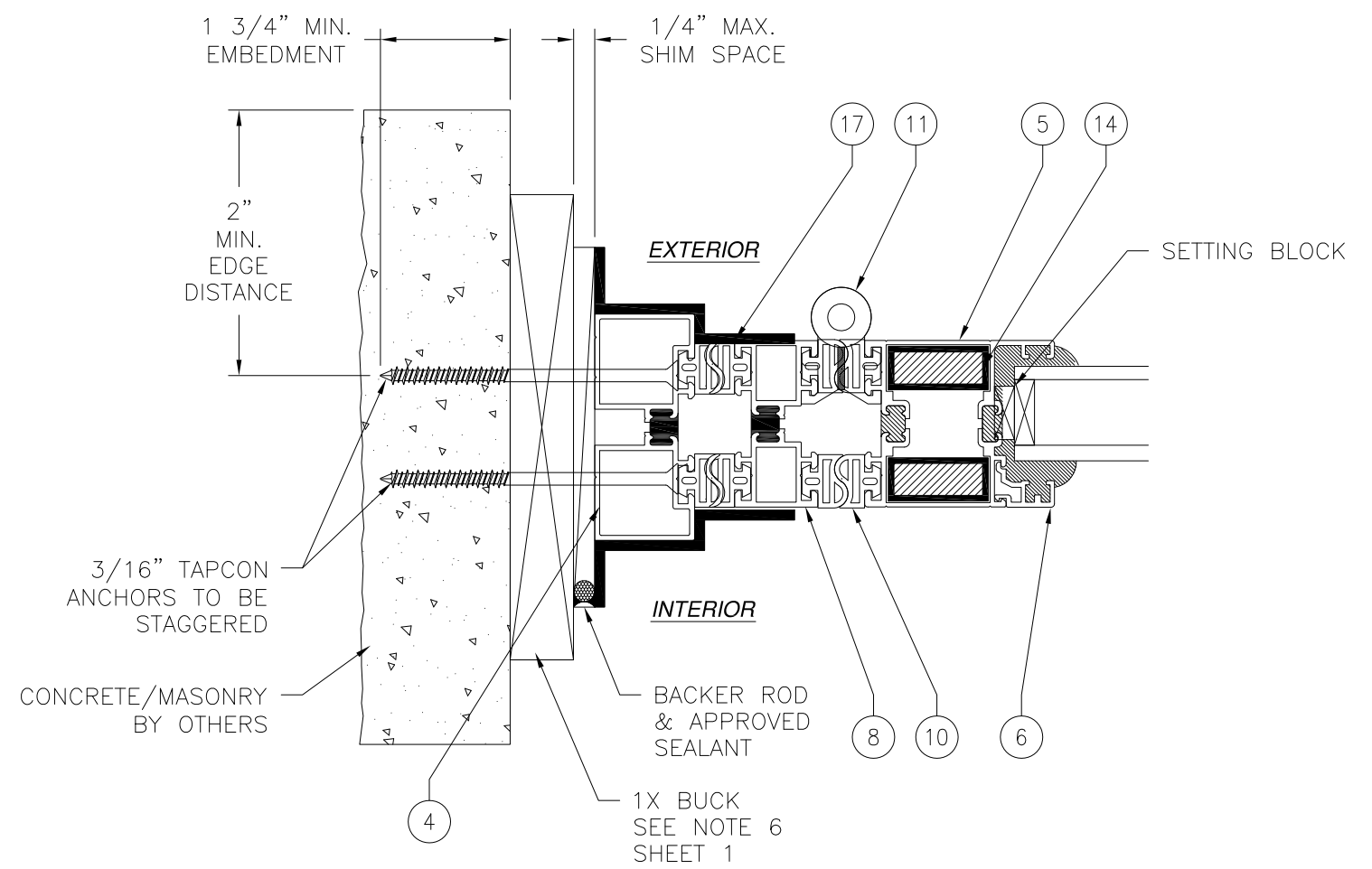

JAMB INSTALLATION DETAIL
CONCRETE/MASONRY W/1X BUCK INSTALLATION

- NOTES:**
1. INTERIOR AND EXTERIOR FINISHES, BY OTHERS, NOT SHOWN FOR CLARITY.
 2. PERIMETER AND JOINT SEALANT BY OTHERS TO BE DESIGNED IN ACCORDANCE WITH ASTM E2112

SIGNED: 12/19/2022

E6 GLOBAL IPA, LLC.
12-1394, 369 GANGNAM-DAERO, SEOCHO-GU
SEOUL 06621, SOUTH KOREA

AZ57-HWF2 TWIN CORE ALUMINUM BIFOLD DOOR
NON-IMPACT
INSTALLATION DETAILS

DRAWN: R.L.	DWG NO. 08-03852	REV -
SCALE NTS	DATE 11/18/2022	SHEET 5 OF 7

L. ROBERTO LOMAS P.E.
400 S. PALM AVE, INDIAN LANTIC, FL 32903
434-688-0609 rllomas@rlomaspe.com

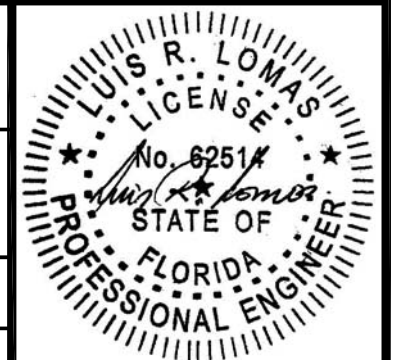

Luis R. Lomas P.E.
FL No.: 62514

REVISIONS			
REV	DESCRIPTION	DATE	APPROVED

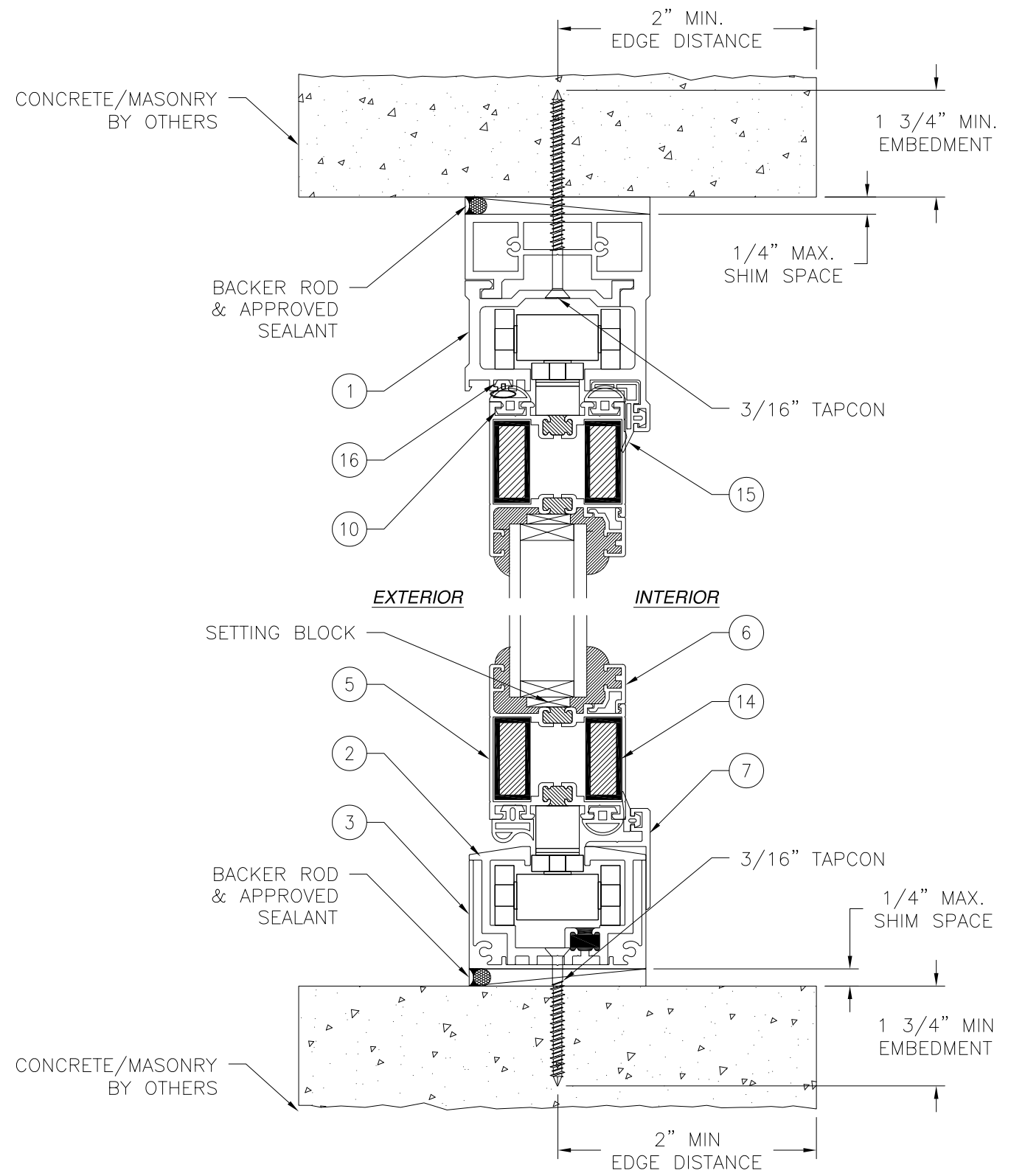

VERTICAL CROSS SECTION
CONCRETE/MASONRY INSTALLATION

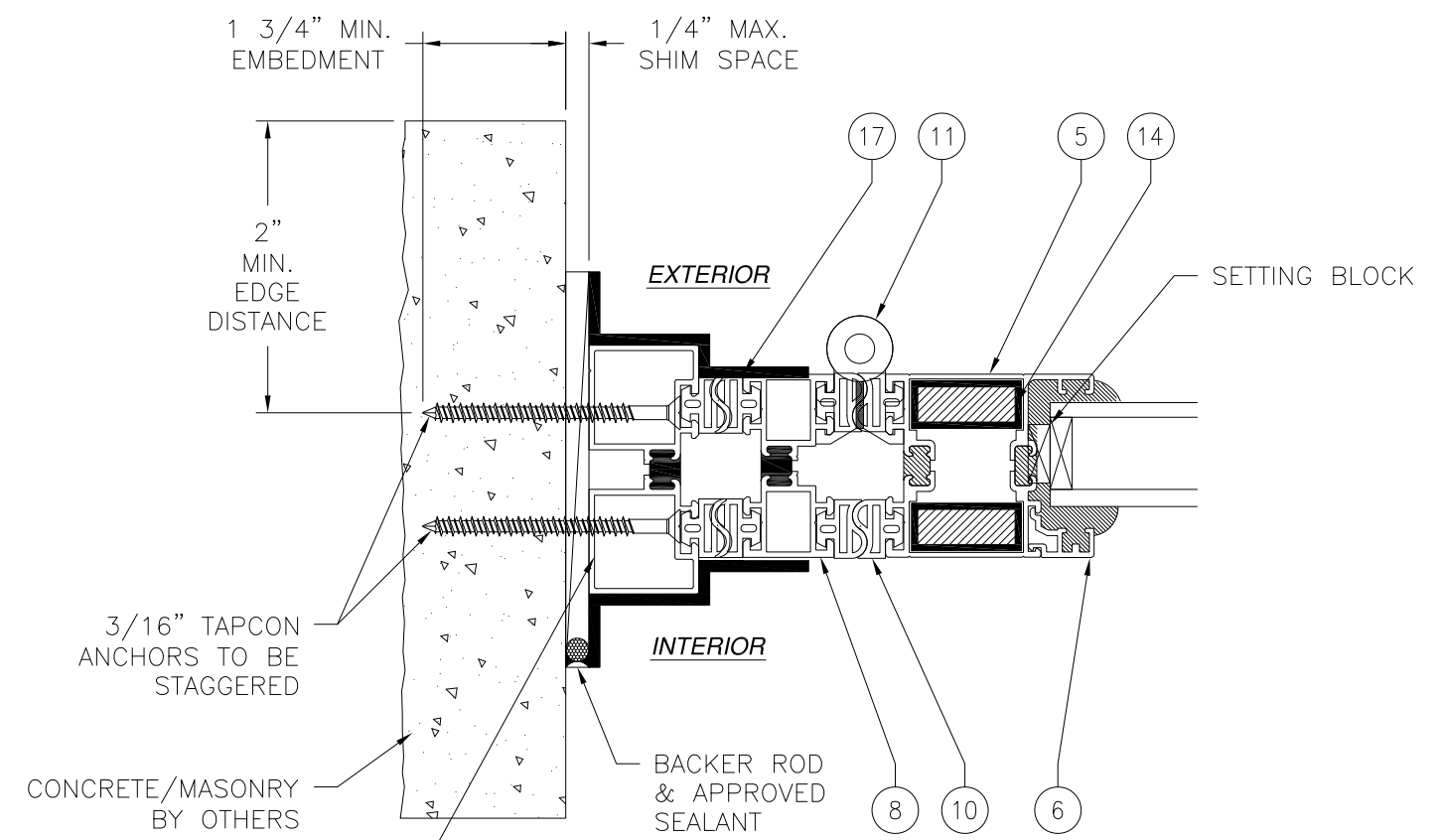

JAMB INSTALLATION DETAIL
CONCRETE/MASONRY INSTALLATION

- NOTES:**
1. INTERIOR AND EXTERIOR FINISHES, BY OTHERS, NOT SHOWN FOR CLARITY.
 2. PERIMETER AND JOINT SEALANT BY OTHERS TO BE DESIGNED IN ACCORDANCE WITH ASTM E2112

SIGNED: 12/19/2022

E6 GLOBAL IPA, LLC. 12-1394, 369 GANGNAM-DAERO, SEOCHO-GU SEOUL 06621, SOUTH KOREA		
AZ57-HWF2 TWIN CORE ALUMINUM BIFOLD DOOR NON-IMPACT INSTALLATION DETAILS		
DRAWN: R.L.	DWG NO. 08-03852	REV -
SCALE NTS	DATE 11/18/2022	SHEET 6 OF 7
L. ROBERTO LOMAS P.E. 400 S. PALM AVE, INDIALANTIC, FL 32903 434-688-0609 rllomas@rlomaspe.com		

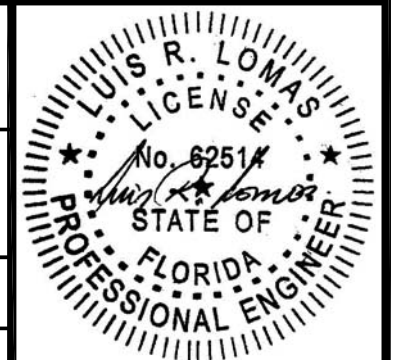

Luis R. Lomas P.E.
FL No.: 62514

BILL OF MATERIALS		
ITEM NO.:	DESCRIPTION	MATERIAL
1	TOP TRACK	ALUMINUM
2	BOTTOM TRACK	ALUMINUM
3	BOTTOM TRACK COVER	ALUMINUM
4	SIDE FRAME	ALUMINUM
5	DOOR FRAME	ALUMINUM
6	GLASS RETAINING STRIP	ALUMINUM
7	WINDOW FLANGE	ALUMINUM
8	SLIDE BAR	ALUMINUM
9	HANDLE	ZINC
10	DOOR GASKET	RUBBER
11	HINGE	ALUMINUM
12	MOHAIR	POLYPROPYLENE
13	BEARING SET	STAINLESS STEEL
14	TWIN CORE	ALUMINUM
15	TOP TRACK GASKET	RUBBER
16	O SHAPE GASKET	RUBBER
17	L BRACKET	ALUMINUM

REVISIONS			
REV	DESCRIPTION	DATE	APPROVED

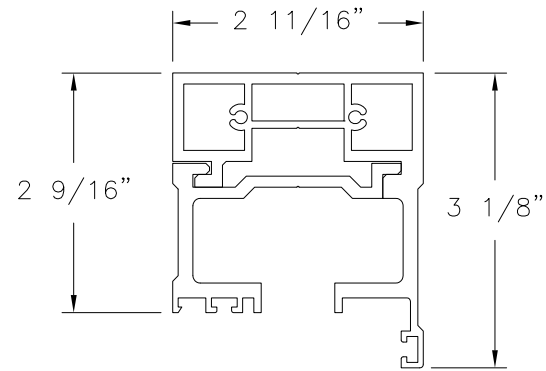

① **TOP TRACK**
ALUMINUM 6063-T5

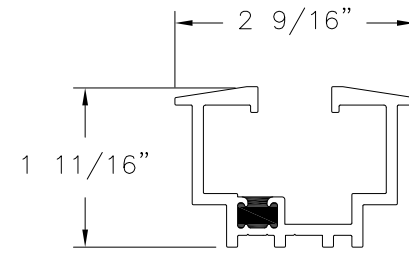

② **BOTTOM TRACK**
ALUMINUM 6063-T5

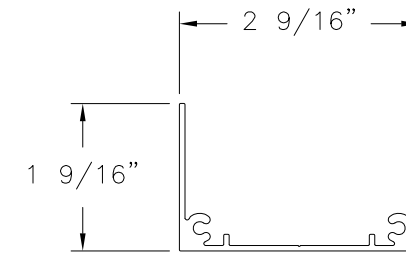

③ **BOTTOM TRACK COVER**
ALUMINUM 6063-T5

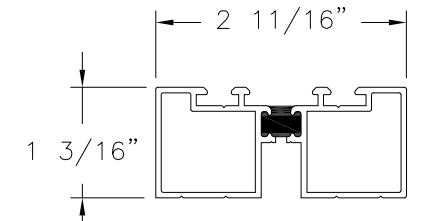

④ **SIDE FRAME**
ALUMINUM 6063-T5

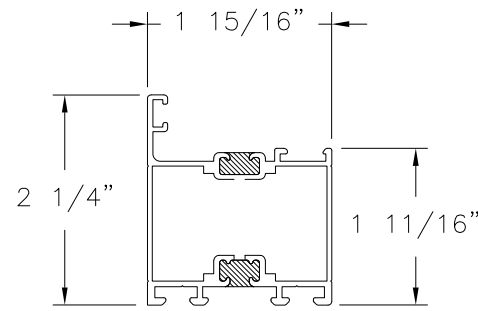

⑤ **DOOR FRAME**
ALUMINUM 6063-T5

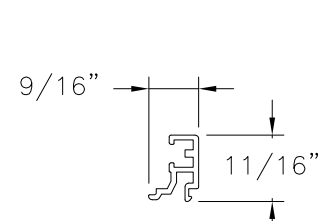

⑥ **GLASS RETAINING STRIP**
ALUMINUM 6063-T5

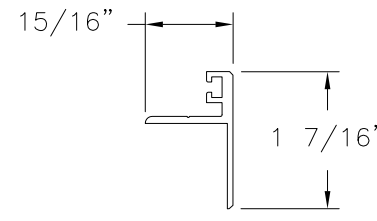

⑦ **WINDOW FLANGE**
ALUMINUM 6063-T5

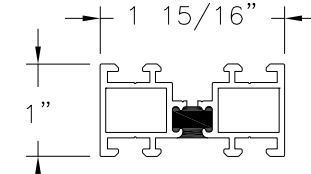

⑧ **SLIDE BAR**
ALUMINUM 6063-T5

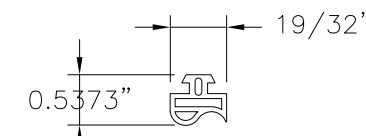

⑩ **SIDE DOOR GASKET**
RUBBER

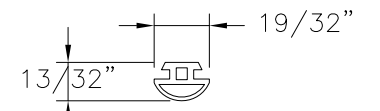

⑩ **TOP DOOR GASKET**
RUBBER

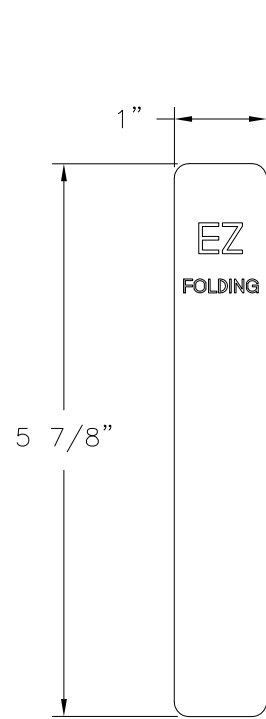

⑨ **HANDLE**
ZINC

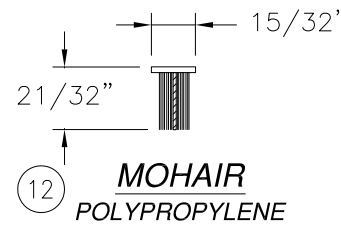

⑫ **MOHAIR**
POLYPROPYLENE

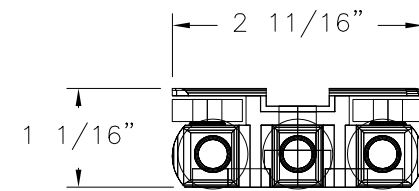

⑬ **TOP AND BOTTOM BEARING SET**
STAINLESS STEEL

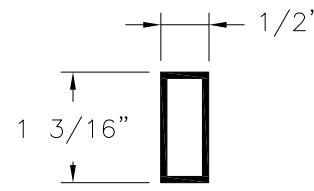

⑭ **TWIN CORE**
ALUMINUM 6063-T5

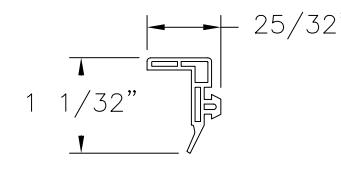

⑮ **TOP TRACK GASKET**
RUBBER

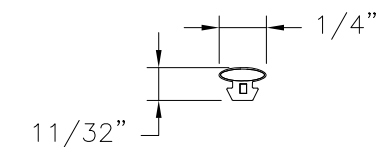

⑯ **O SHAPE GASKET**
RUBBER

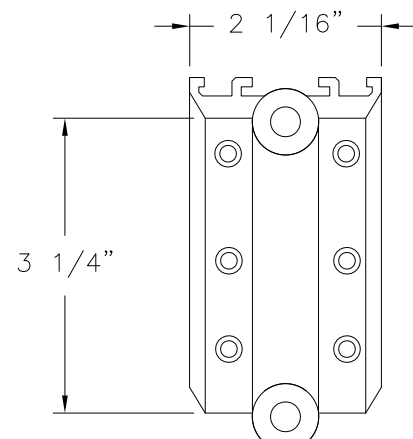

⑪ **HINGE**
ALUMINUM 6063-T5

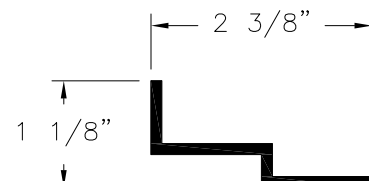

⑰ **L BRACKET**
ALUMINUM 6063-T5

SIGNED: 12/19/2022

E6 GLOBAL IPA, LLC.

12-1394, 369 GANGNAM-DAERO, SEOCHO-GU
SEOUL 06621, SOUTH KOREA

AZ57-HWF2 TWIN CORE ALUMINUM BIFOLD DOOR
NON-IMPACT
COMPONENTS

DRAWN: R.L.	DWG NO. 08-03852	REV -
SCALE NTS	DATE 11/18/2022	SHEET 7 OF 7

L. ROBERTO LOMAS P.E.
400 S. PALM AVE, INDIALANTIC, FL 32903
434-688-0609 rllomas@rlomaspe.com

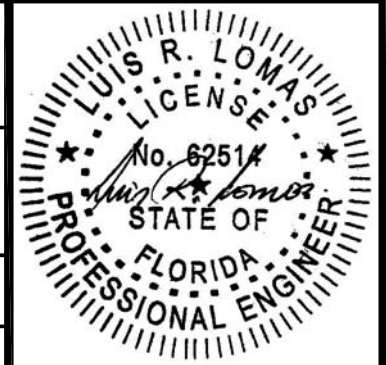

Luis R. Lomas P.E.
FL No.: 62514