

REVISIONS			
REV	DESCRIPTION	DATE	APPROVED

NOTES:

1. THE PRODUCT SHOWN HEREIN IS DESIGNED AND MANUFACTURED TO COMPLY WITH REQUIREMENTS OF THE FLORIDA BUILDING CODE.
2. WOOD FRAMING AND MASONRY OPENING TO BE DESIGNED AND ANCHORED TO PROPERLY TRANSFER ALL LOADS TO STRUCTURE. FRAMING AND MASONRY OPENING IS THE RESPONSIBILITY OF THE ARCHITECT OR ENGINEER OF RECORD.
3. ALLOWABLE STRESS INCREASE OF 1/3 WAS NOT USED IN THE DESIGN OF THE PRODUCT SHOWN HEREIN. WIND LOAD DURATION FACTOR Cd=1.6 WAS USED FOR WOOD ANCHOR CALCULATIONS.
4. APPROVED IMPACT PROTECTIVE SYSTEM IS NOT REQUIRED FOR THIS PRODUCT IN WIND BORNE DEBRIS REGIONS UP TO WIND ZONE 3.
5. DESIGN PRESSURE AND INSTALLATION DETAILS SHOWN IN THIS DOCUMENT APPLY ONLY TO THE MULLION. WINDOWS MUST BE APPROVED UNDER SEPARATE APPROVAL.
6. SINGLE UNITS TO BE MULLED ARE NOT LIMITED TO THOSE SHOWN IN THIS DRAWING. SINGLE UNITS TO BE MULLED TOGETHER MUST BE MANUFACTURED BY MI WINDOWS AND DOORS.
7. DESIGN PRESSURE OF MULLED UNIT SHALL BE CONTROLLED BY THE LESSER DESIGN PRESSURE OF THE MULLION OR THE INDIVIDUAL WINDOW UNIT.
8. VERTICAL MULLIONS ARE NOT PART OF THIS APPROVAL. VERTICAL MULLIONS USED TO MULL UNITS SIDE BY SIDE MUST HAVE SEPARATE APPROVAL.
9. FOR ADDITIONAL APPROVED CONFIGURATIONS SEE SHEET 2.

ANCHORING NOTES:

1. FOR ANCHORING INTO CONCRETE USE 1/4" TAPCON WITH SUFFICIENT LENGTH TO ACHIEVE A 1 3/4" MINIMUM EMBEDMENT INTO SUBSTRATE WITH 1 1/2" MINIMUM EDGE DISTANCE. LOCATE ANCHORS AS SHOWN IN ELEVATIONS AND INSTALLATION DETAILS.
2. FOR ANCHORING INTO WOOD FRAMING OR 2X BUCK USE #10 WOOD SCREW WITH SUFFICIENT LENGTH TO ACHIEVE A 1 1/4" MINIMUM EMBEDMENT INTO SUBSTRATE. LOCATE ANCHORS AS SHOWN IN ELEVATIONS AND INSTALLATION DETAILS.
3. FOR ANCHORING INTO METAL STRUCTURE USE #10 SMS OR SELF DRILLING SCREW WITH SUFFICIENT LENGTH TO ACHIEVE A 3 THREADS MINIMUM BEYOND STRUCTURE INTERIOR WALL. LOCATE ANCHORS AS SHOWN IN ELEVATIONS AND INSTALLATION DETAILS.
4. FOR ATTACHING WINDOW UNITS TO MULLION USE #10 SMS OR SELF DRILLING SCREWS WITH SUFFICIENT LENGTH TO ACHIEVE A MINIMUM EMBEDMENT OF THREE THREADS PAST THE MULLION WALL. LOCATE SCREWS 6" FROM EACH MULLION END AND 12" MAX. O.C. THEREAFTER. STAGGER SCREWS AT EACH WINDOW.
5. FOR WINDOW UNITS ANCHORING SCHEDULE REFER TO WINDOW APPROVED INSTALLATION INSTRUCTIONS.
6. ALL FASTENERS TO BE CORROSION RESISTANT.
7. INSTALLATION ANCHORS SHALL BE INSTALLED IN ACCORDANCE WITH ANCHOR MANUFACTURER'S INSTALLATION INSTRUCTIONS, AND ANCHORS SHALL NOT BE USED IN SUBSTRATES WITH STRENGTHS LESS THAN THE MINIMUM STRENGTH SPECIFIED BELOW:
 - A. WOOD – MINIMUM SPECIFIC GRAVITY OF G=0.42
 - B. CONCRETE – MINIMUM COMPRESSIVE STRENGTH OF 2,000 PSI.
 - C. METAL – STEEL 18GA (.048") FY=33KSI/FU=52 OR ALUMINUM 6063-T5 FU=30KSI .125" THICK MINIMUM.

SIGNED: 04/24/2023

TABLE OF CONTENTS	
SHEET NO.	DESCRIPTION
1	NOTES
2	ELEVATIONS AND DESIGN PRESSURE CHARTS
3	INSTALLATION DETAILS
4	INSTALLATION DETAILS & COMPONENTS

MI WINDOWS AND DOORS, LLC 650 WEST MARKET STREET GRATZ, PA 17030-0370		
M-9316 HORIZONTAL MULLION NOTES		
DRAWN: A.R.	DWG NO. 08-03683	REV -
SCALE NTS	DATE 01/26/21	SHEET 1 OF 4
L. ROBERTO LOMAS P.E. 1432 WOODFORD RD LEWISVILLE, NC 27023 434-688-0609 rllomas@rlomaspe.com		

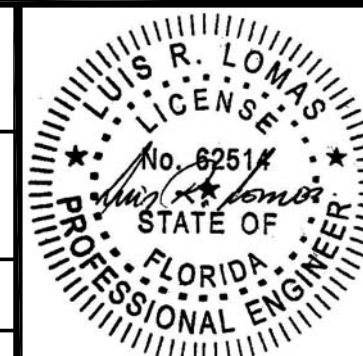

Luis R. Lomas P.E.
FL No.: 62514

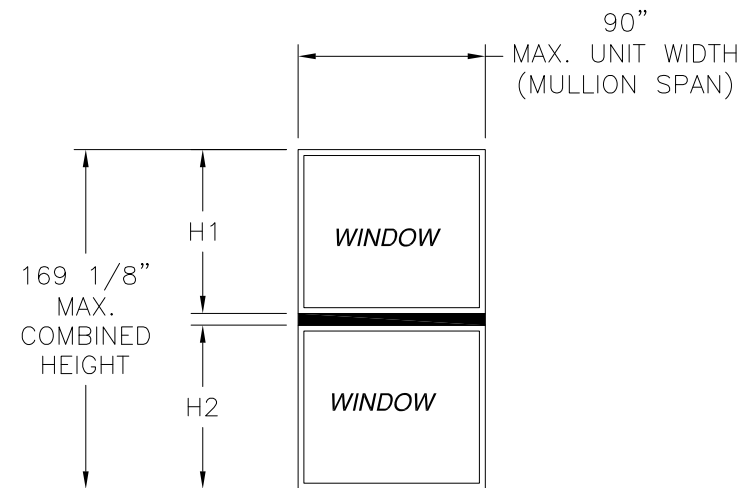

Chart #1
Maximum design pressure (psf)

Tributary height	Mullion span (in)										
	18.00	24.00	30.00	36.00	42.00	48.00	52.13	54.00	60.00	84.00	90.00
18.00	120.0	120.0	120.0	120.0	120.0	120.0	120.0	120.0	120.0	120.0	111.6
24.00	120.0	120.0	120.0	120.0	120.0	120.0	120.0	120.0	120.0	94.1	86.9
30.00	120.0	120.0	120.0	120.0	120.0	120.0	120.0	120.0	120.0	78.6	72.3
36.00	120.0	120.0	120.0	120.0	120.0	120.0	120.0	120.0	107.6	68.5	62.8
37.38	120.0	120.0	120.0	120.0	120.0	120.0	120.0	120.0	105.3	66.6	61.0
42.00	120.0	120.0	120.0	120.0	120.0	120.0	120.0	117.4	99.3	61.5	55.2
48.00	120.0	120.0	120.0	120.0	120.0	120.0	120.0	113.0	94.1	56.5	49.4
49.63	120.0	120.0	120.0	120.0	120.0	120.0	120.0	112.3	93.1	55.4	48.2
54.00	120.0	120.0	120.0	120.0	120.0	120.0	119.7	111.6	91.3	52.8	45.2
60.00	120.0	120.0	120.0	120.0	120.0	120.0	119.7	111.6	90.4	49.5	42.0
62.00	120.0	120.0	120.0	120.0	120.0	120.0	119.7	111.6	90.4	48.6	41.2
66.00	120.0	120.0	120.0	120.0	120.0	120.0	119.7	111.6	90.4	47.0	39.7
72.00	120.0	120.0	120.0	120.0	120.0	120.0	119.7	111.6	90.4	45.4	37.9
78.00	120.0	120.0	120.0	120.0	120.0	120.0	119.7	111.6	90.4	44.4	36.7
84.00	120.0	120.0	120.0	120.0	120.0	120.0	119.7	111.6	90.4	44.0	36.0

Large and small missile impact up to wind zone 3

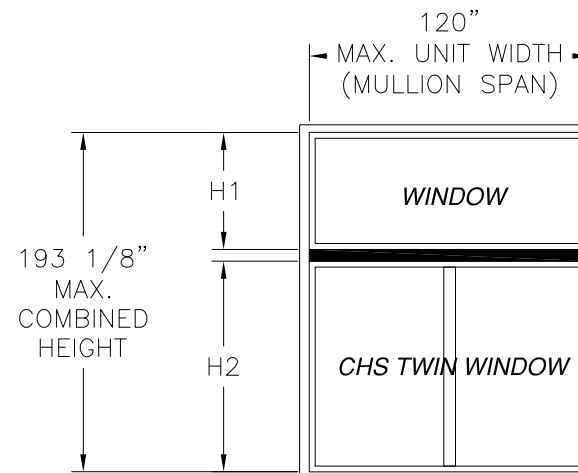

Chart #2
Maximum design pressure capacity chart (psf)

Tributary Height (in)	Mullion Span (in)							
	48.00	60.00	72.00	84.00	96.00	104.25	108.00	120.00
18.00	120.0	120.0	120.0	120.0	102.4	79.7	71.6	52.0
24.00	120.0	120.0	113.0	94.1	77.9	60.5	54.3	39.4
30.00	120.0	120.0	95.1	78.6	63.4	49.1	44.1	31.9
36.00	120.0	106.9	83.7	68.5	53.7	41.6	37.3	26.9
37.38	120.0	104.4	81.6	66.6	51.8	40.2	36.1	26.0
42.00	120.0	97.2	75.6	61.3	46.4	36.3	32.5	23.4
48.00	120.0	89.9	69.5	54.3	41.0	32.4	29.0	20.8
49.63	120.0	88.3	68.1	52.8	39.8	31.5	28.2	20.2
54.00	118.9	84.4	64.8	49.0	36.9	29.4	26.3	18.8
60.00	113.0	80.3	61.1	44.9	33.7	27.0	24.1	17.2
62.00	111.1	79.1	60.0	43.7	32.7	26.3	23.5	16.8
66.00	107.6	76.9	58.1	41.7	31.1	25.1	22.4	15.9
72.00	102.7	73.8	55.8	39.0	28.9	23.5	20.9	-
78.00	98.2	70.9	53.3	36.9	27.2	22.2	19.7	-
84.00	94.1	68.2	50.9	35.2	25.8	21.1	18.7	-

Large and small missile impact up to wind zone 3

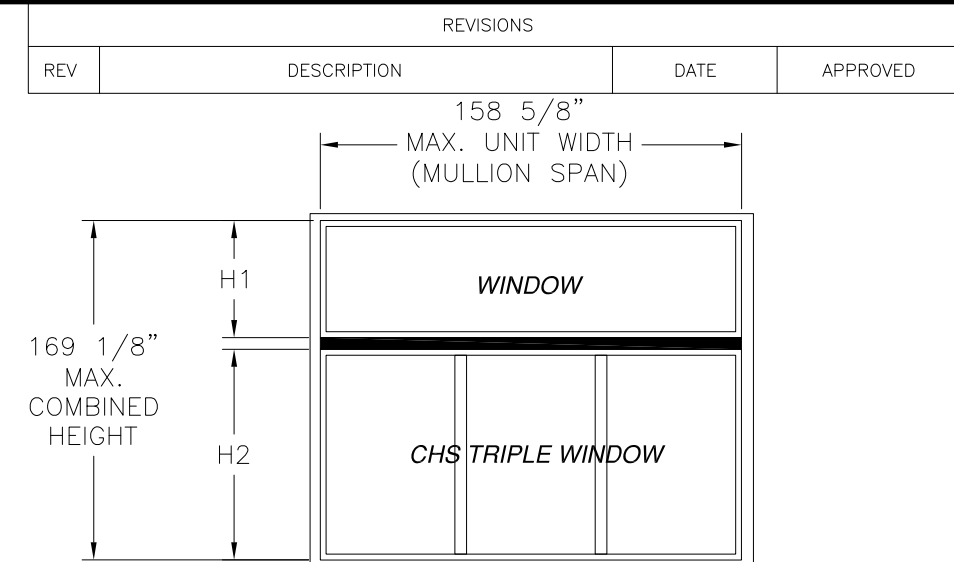

Chart #3
Maximum design pressure capacity chart (psf)

Tributary Height (in)	Mullion Span (in)						
	54.00	72.00	90.00	108.00	126.00	144.00	156.38
18.00	120.0	120.0	111.6	72.9	45.7	30.6	23.8
24.00	120.0	113.0	86.9	55.2	34.6	23.1	18.0
30.00	120.0	94.6	72.3	44.7	27.9	18.6	-
36.00	118.1	82.1	61.9	37.7	23.5	15.6	-
37.38	115.1	79.8	59.9	36.5	22.7	15.1	-
42.00	106.3	73.2	54.0	32.8	20.4	-	-
48.00	97.7	66.4	48.0	29.1	18.0	-	-
49.63	95.8	64.9	46.7	28.2	17.5	-	-
54.00	91.3	61.3	43.5	26.2	16.2	-	-
60.00	86.1	57.2	39.9	23.9	-	-	-
62.00	84.4	56.0	38.8	23.3	-	-	-
66.00	81.4	53.9	37.0	22.1	-	-	-
72.00	77.2	51.3	34.7	20.6	-	-	-
78.00	73.5	49.1	32.8	19.3	-	-	-
84.00	70.0	47.1	31.2	18.3	-	-	-

Large and small missile impact up to wind zone 3

REVISIONS			
REV	DESCRIPTION	DATE	APPROVED

DESIGN PRESSURE TABLE INSTRUCTIONS:

1. DEFINE REQUIRED DESIGN LOAD PER FLORIDA BUILDING CODE CHAPTER 16.
2. DETERMINE TRIBUTARY HEIGHT AND MULLION SPAN BASED ON PRODUCT TO BE INSTALLED. SEE FORMULA FOR TRIBUTARY HEIGHT.
3. LOCATE MULLION SPAN (UNIT WIDTH) AND TRIBUTARY HEIGHT. AT THE INTERSECTION OF COLUMN AND ROW CONTAINING THE MULLION SPAN AND TRIBUTARY WIDTH RESPECTIVELY IS THE MULLION RATING FOR PRODUCT IN STEP 2. MULLION RATING MUST BE EQUAL OR GREATER THAN REQUIRED DESIGN PRESSURE OBTAINED IN STEP 1.

$$\text{TRIBUTARY HEIGHT} = \frac{H1 + H2}{2}$$

MI WINDOWS AND DOORS, LLC

650 WEST MARKET STREET
GRATZ, PA 17030-0370

M-9316
HORIZONTAL MULLION
ELEVATIONS AND DESIGN PRESSURE CHARTS

DRAWN: A.R.	DWG NO. 08-03683	REV -
SCALE NTS	DATE 01/26/21	SHEET 2 OF 4

L. ROBERTO LOMAS P.E.
1432 WOODFORD RD LEWISVILLE, NC 27023
434-688-0609 rllomas@rlomaspe.com

SIGNED: 04/24/2023

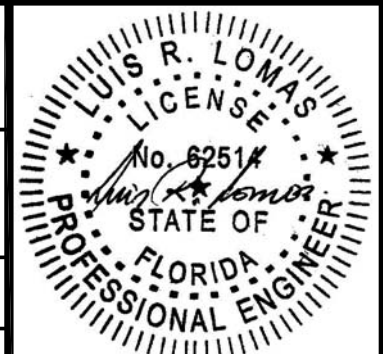

Luis R. Lomas P.E.
FL No.: 62514

REVISIONS			
REV	DESCRIPTION	DATE	APPROVED

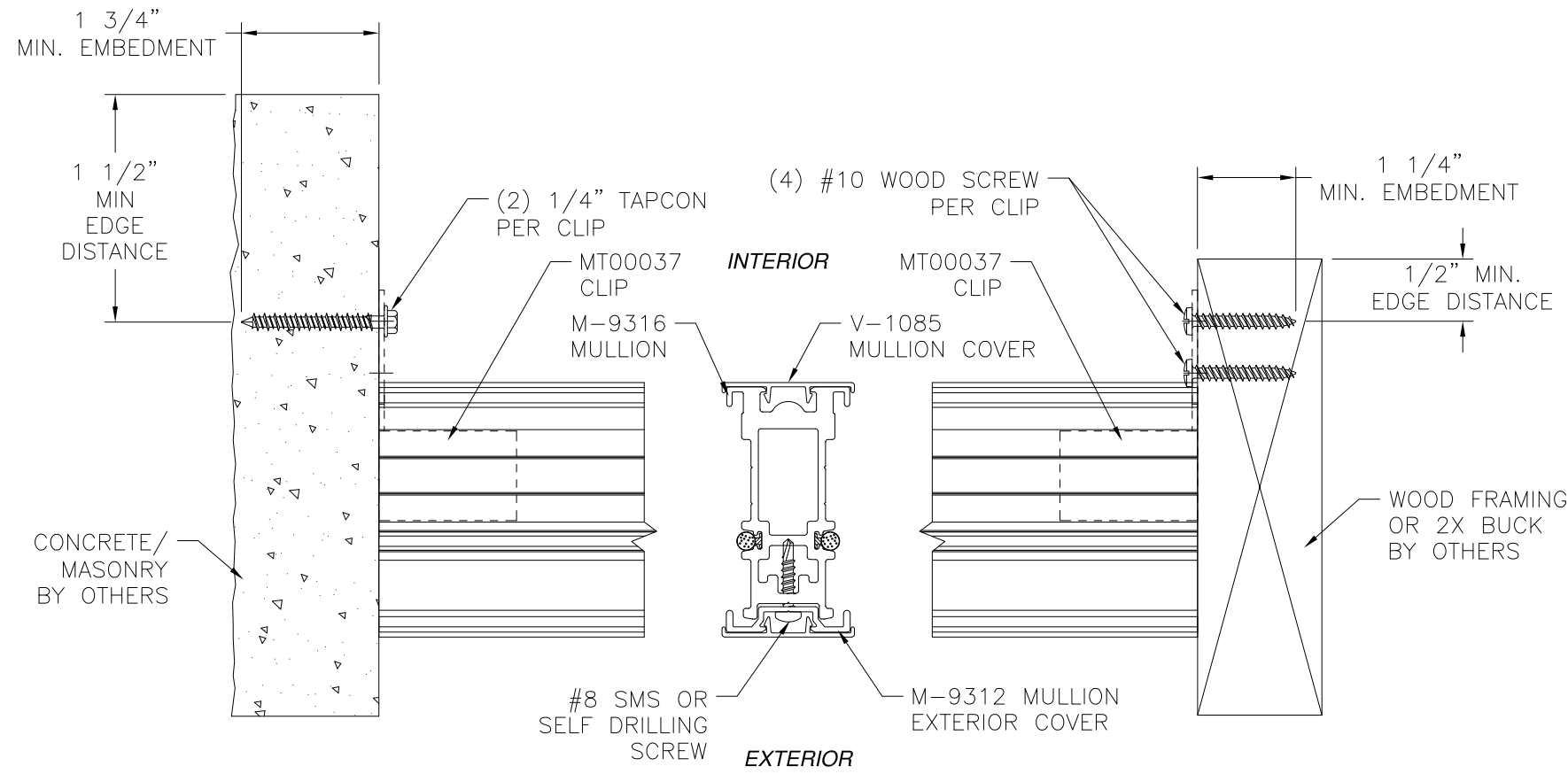

MULLION INSTALLATION
WOOD & CONCRETE

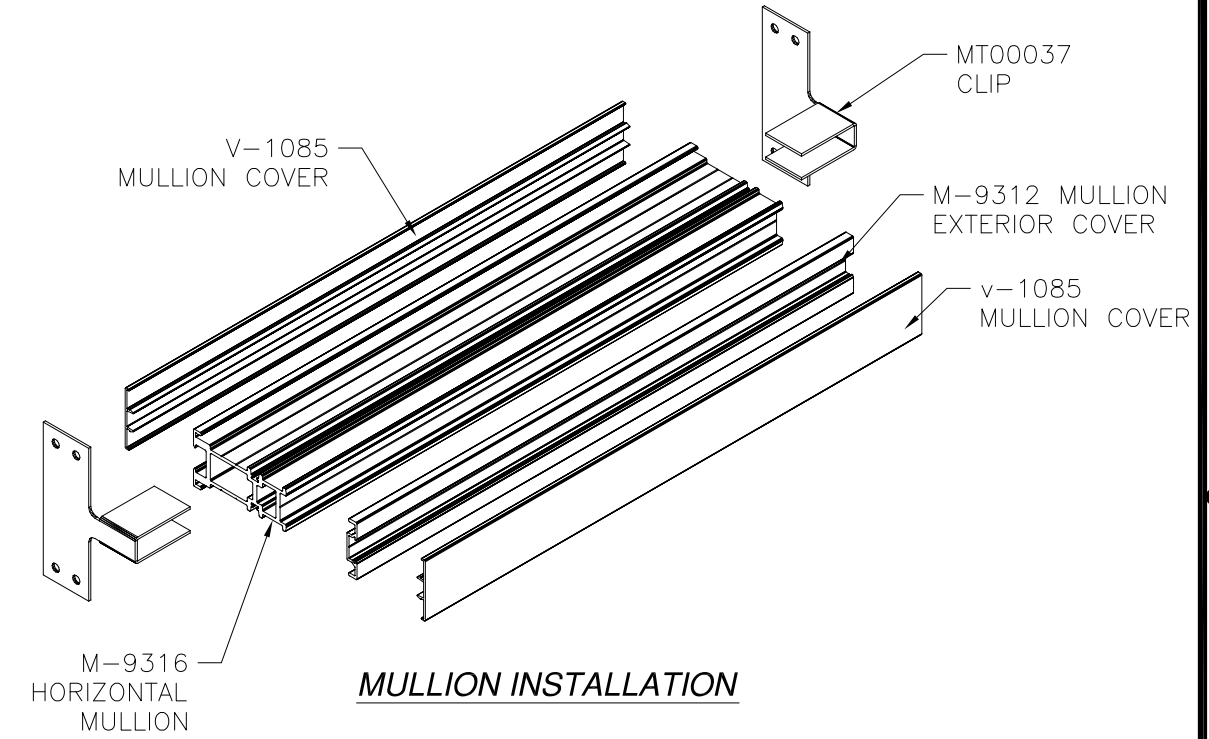

MULLION INSTALLATION

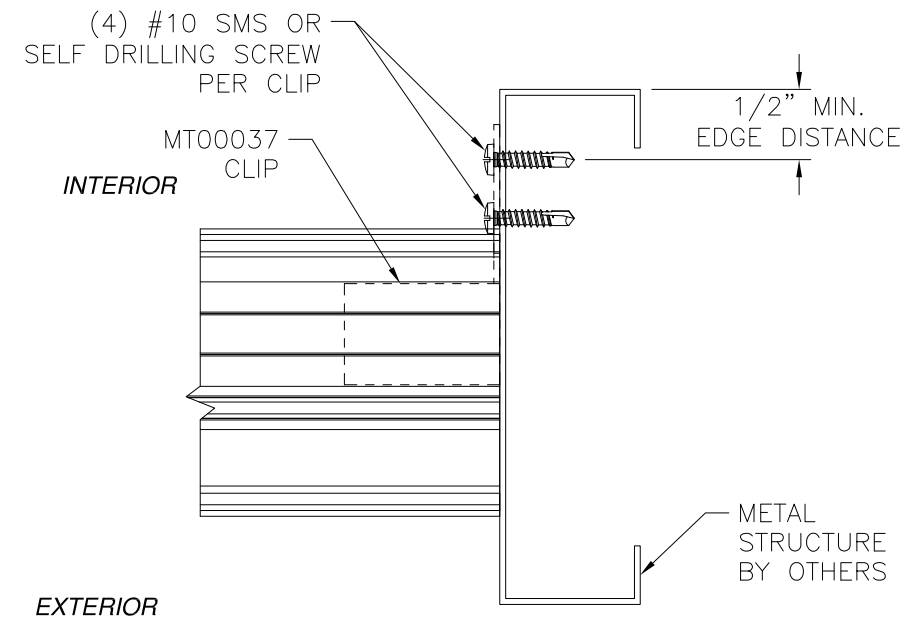

MULLION INSTALLATION
METAL STRUCTURE

SIGNED: 04/24/2023

MI WINDOWS AND DOORS, LLC
650 WEST MARKET STREET
GRATZ, PA 17030-0370

M-9316
HORIZONTAL MULLION
INSTALLATION DETAILS

DRAWN: A.R.	DWG NO. 08-03683	REV -
SCALE NTS	DATE 01/26/21	SHEET 3 OF 4

L. ROBERTO LOMAS P.E.
1432 WOODFORD RD LEWISVILLE, NC 27023
434-688-0609 rllomas@rlomaspe.com

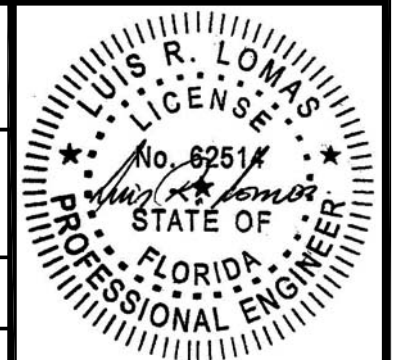

Luis R. Lomas P.E.
FL No.: 62514

REVISIONS			
REV	DESCRIPTION	DATE	APPROVED

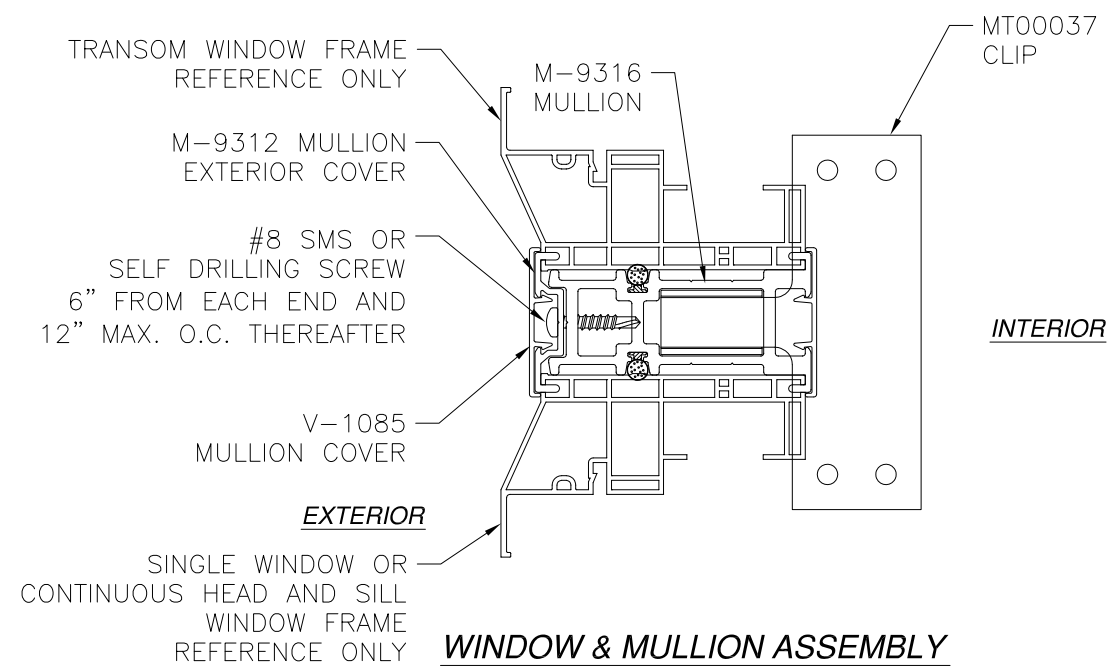
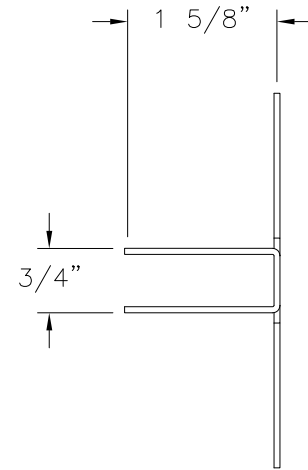
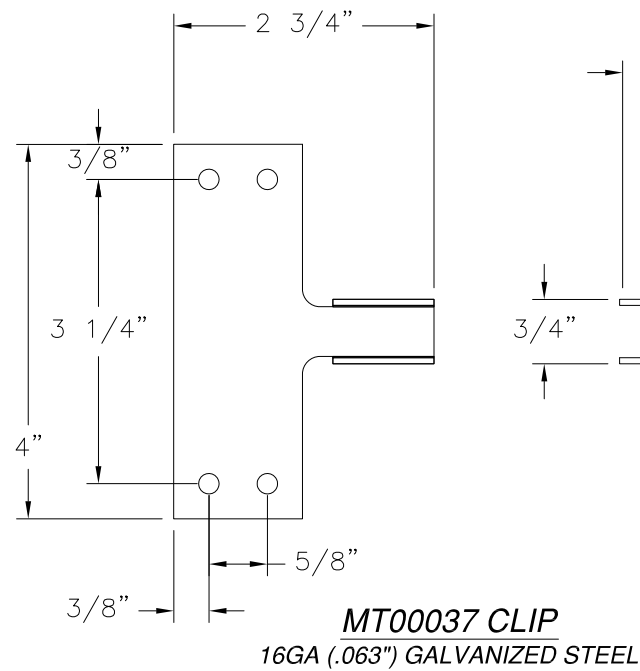
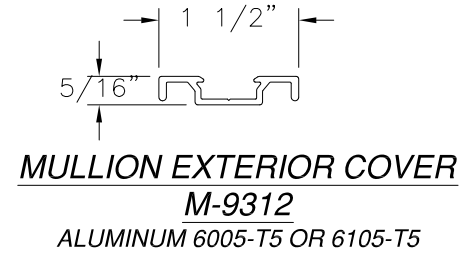
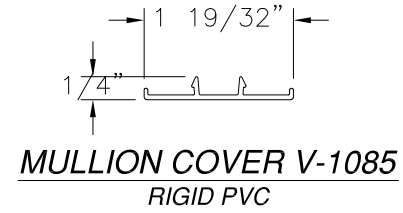
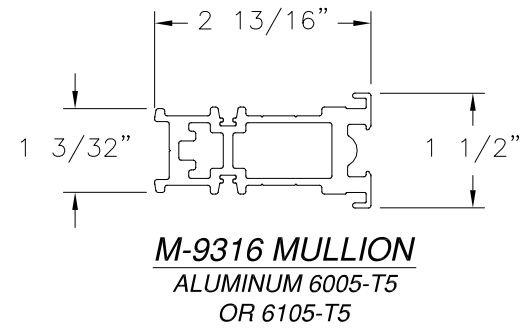

WINDOW & MULLION ASSEMBLY
MULLION CAN BE USED WITH VARIOUS WINDOW PROFILES

SIGNED: 04/24/2023

MI WINDOWS AND DOORS, LLC
650 WEST MARKET STREET
GRATZ, PA 17030-0370

M-9316
HORIZONTAL MULLION
COMPONENTS

DRAWN: A.R.	DWG NO. 08-03683	REV -
SCALE NTS	DATE 01/26/21	SHEET 4 OF 4

L. ROBERTO LOMAS P.E.
1432 WOODFORD RD LEWISVILLE, NC 27023
434-688-0609 rllomas@rlomaspe.com

Luis R. Lomas P.E.
FL No.: 62514