

GENERAL NOTES

1. THE PRODUCT SHOWN HEREIN CONSTRUCTED FROM LUXVIEW THERMALLY BROKEN ALUMINUM FRAMES HAS BEEN TESTED TO TAS201/202/203-94, AND MEETS THE REQUIREMENTS OF THE FLORIDA BUILDING CODE, 8TH EDITION (2023), INCLUDING THE HIGH VELOCITY HURRICANE ZONE.
2. THIS PRODUCT IS LARGE AND SMALL MISSILE IMPACT RESISTANT AND DOES NOT REQUIRE THE USE OF IMPACT PROTECTIVE DEVICES (SHUTTERS) IN WINDBORNE DEBRIS REGIONS.
3. THE DESIGN PRESSURES INDICATED IN THIS DRAWING ARE AS LIMITED BY ASTM E-1300 GLASS TABLES, AND TESTED WATER, STRUCTURAL, AND CYCLIC PRESSURES.
4. THIS DOCUMENT ADDRESSES PRODUCT ANCHORAGE TO ACHIEVE THE INDICATED DESIGN PRESSURES AT THE INDICATED SIZES, IN THE CONFIGURATION SHOWN IN THE ELEVATIONS. INSTALL PRODUCTS WITH MAXIMUM SHIM GAP, MINIMUM EDGE DISTANCE AND EMBEDMENT, AND WITH FASTENER TYPE AS SHOWN IN THE DETAILS AND AS INDICATED IN TABLE 1. FOR FULL PRODUCT CONSTRUCTION DETAILS SEE INTERTEK TEST REPORT N9351.03-550-44-r0.
6. THE 4/3 ALLOWABLE STRESS INCREASE FACTOR (SHORT-TERM INCREASE FACTOR) HAS NOT BEEN USED IN THE ANCHOR ANALYSIS FOR THIS SYSTEM. THE 1.6 Cd FACTOR WAS USED IN THE ANALYSIS OF ANCHORAGE INTO WOOD SUBSTRATE.
7. THE OPENING SUBSTRATE MATERIALS (FRAMING, MASONRY, BUCKS) AND ATTACHMENT OF BUCKS TO THE SUBSTRATE ARE BY OTHERS AND SHALL BE VERIFIED BY THE ARCHITECT OR ENGINEER OF RECORD OR AS APPROVED BY THE AUTHORITY HAVING JURISDICTION (AHJ). BUCKING, OPENINGS, & BUCKING FASTENERS MUST BE PROPERLY DESIGNED & INSTALLED BY OTHERS IN ACCORDANCE WITH THE FBC TO TRANSFER SUPERIMPOSED LOADS TO THE STRUCTURE. WITH MASONRY OPENINGS, WOOD BUCKS ARE OPTIONAL.
8. DISSIMILAR MATERIALS THAT COME INTO CONTACT SHALL BE COATED OR OTHERWISE PROTECTED TO PREVENT GALVANIC REACTIONS. WOOD BUCKS, IF USED, SHALL BE PRESSURE TREATED, WITH EITHER A TREATMENT OR COATING COMPATIBLE WITH THIS PRODUCT.
9. ALL ANCHORS USED SHALL BE OF A MATERIAL OR HAVE A COATING COMPATIBLE WITH THE PRESSURE TREATED WOOD BUCKS AND ALL OTHER WINDOW MATERIALS.
10. ALL HARDWARE & FASTENERS SHALL BE IN ACCORDANCE WITH THESE DRAWINGS, OR AS APPROVED, SIGNED, AND SEALED BY A FLORIDA REGISTERED PROFESSIONAL ENGINEER ON A SITE-SPECIFIC BASIS.
11. SEALING AND FLASHING STRATEGIES FOR OVERALL WATER INFILTRATION RESISTANCE OF THE INSTALLED PRODUCT SHALL BE THE RESPONSIBILITY OF OTHERS AND ARE NOT ADDRESSED BY THIS DOCUMENT.
12. FOR ADDITIONAL REQUIREMENTS SEE GENERAL ANCHOR NOTES, SHEET 2.

LUXVIEW SWING 77 OUTSWING DOOR

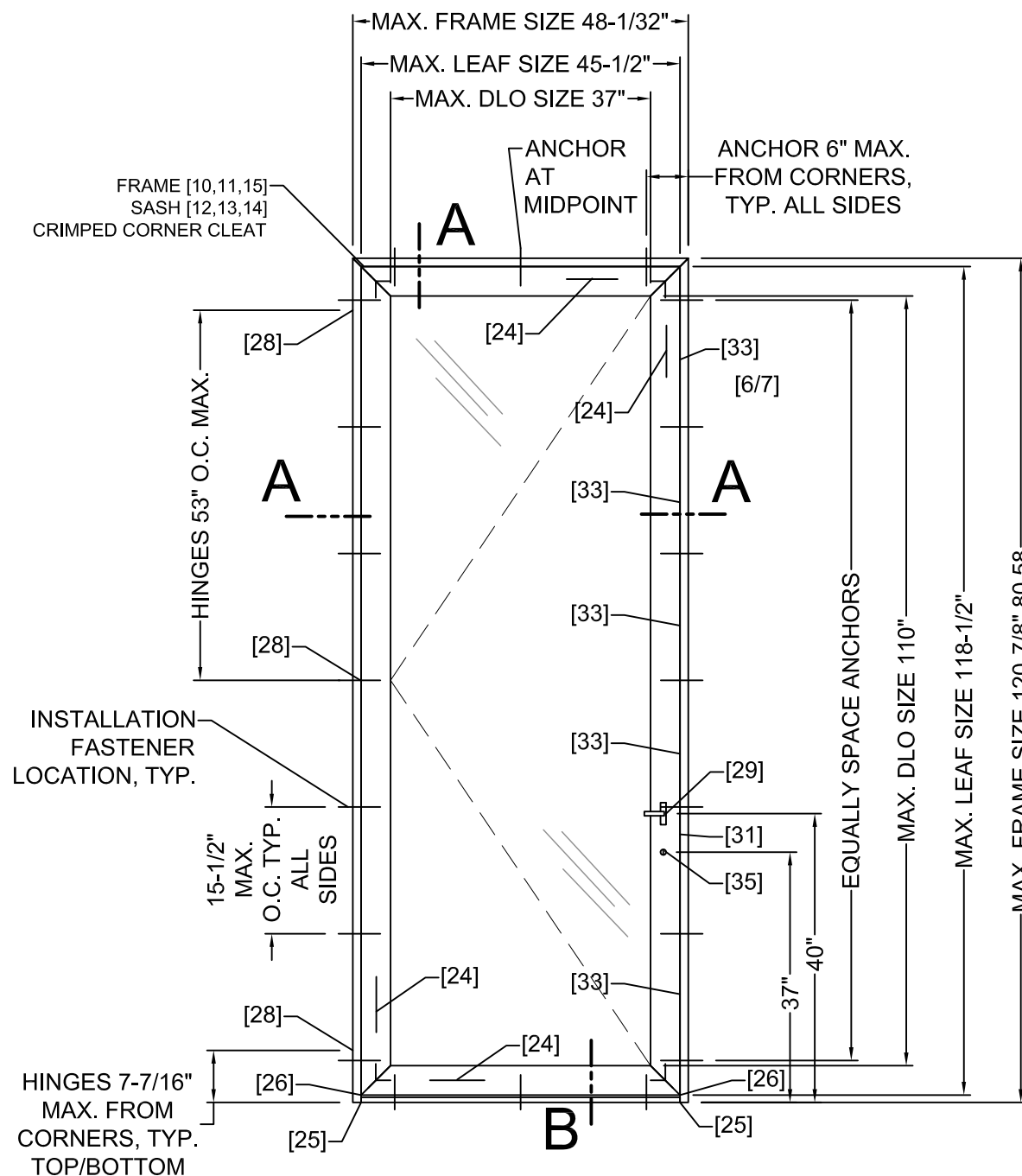

**TYP. ELEVATION
SEE DETAILS SHEET 3**

DESIGN PRESSURE RATING, PSF	IMPACT RATING
+50 / -65	LARGE AND SMALL MISSILE IMPACT

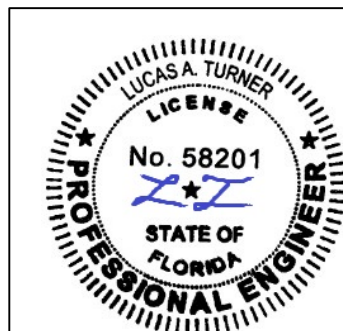

10/23/2023
 Lucas A. Turner, P.E.
 FL PE #58201
 Turner Engineering & Consulting, Inc.
 2428 Old Natchez Trc Trl
 Camden, TN 38320
 Ph. 941-380-1574

<p>LUXVIEW</p> <p>12605 Old Hickory Blvd Ste. 100 Antioch, TN 37013 615-200-7843</p>		Date: 6/26/2023
		Rev: A
Sheet Title: NOTES, ELEVATION	Dwg: FPA-SWING77	Scale: NTS
LUXVIEW PROPRIETARY COPYRIGHT 2023 LUXVIEW LLC	Sheet: 1 of 3	

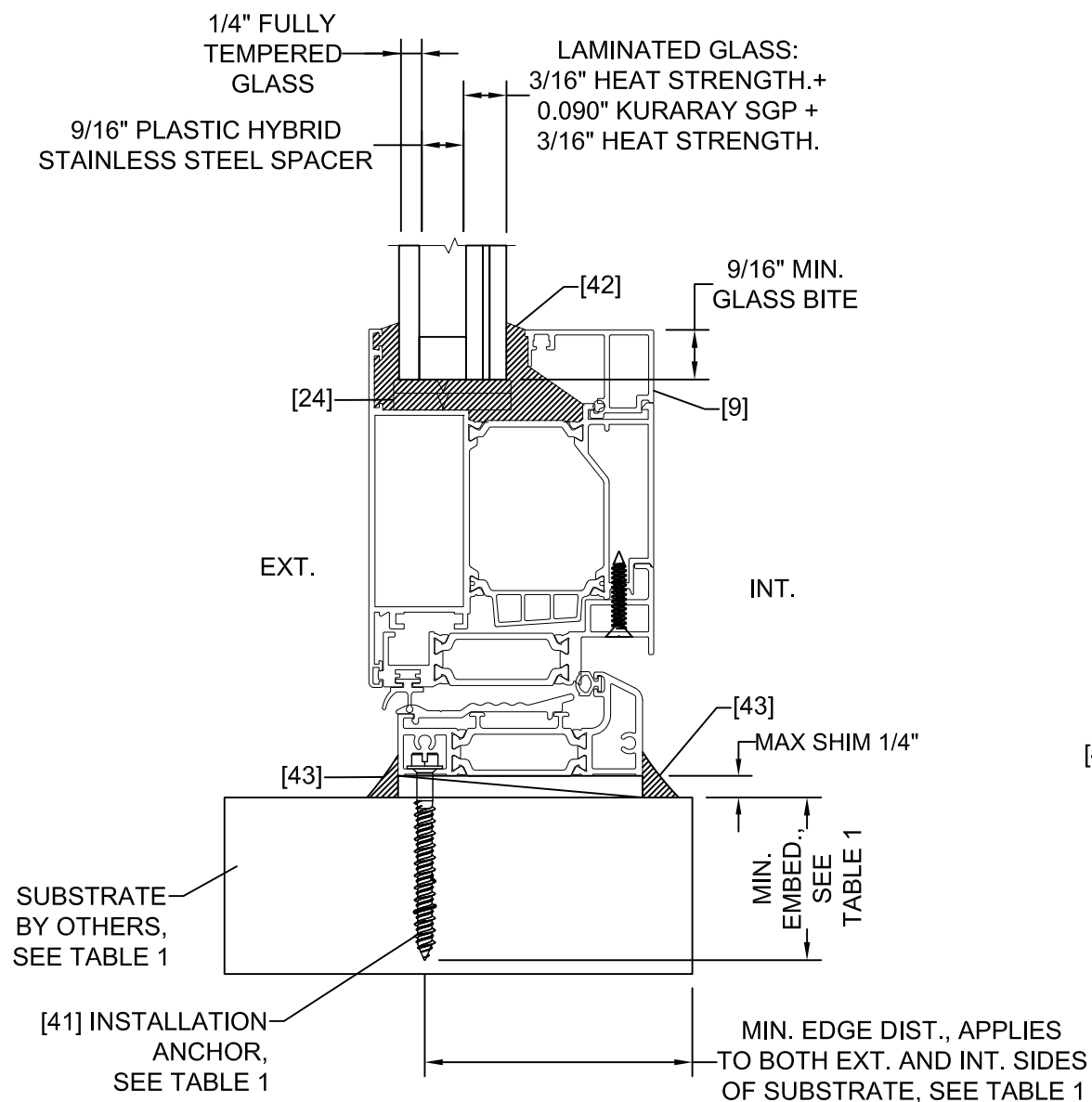

TYPICAL GLAZING DETAIL AND TYP. SILL INSTALLATION DETAIL

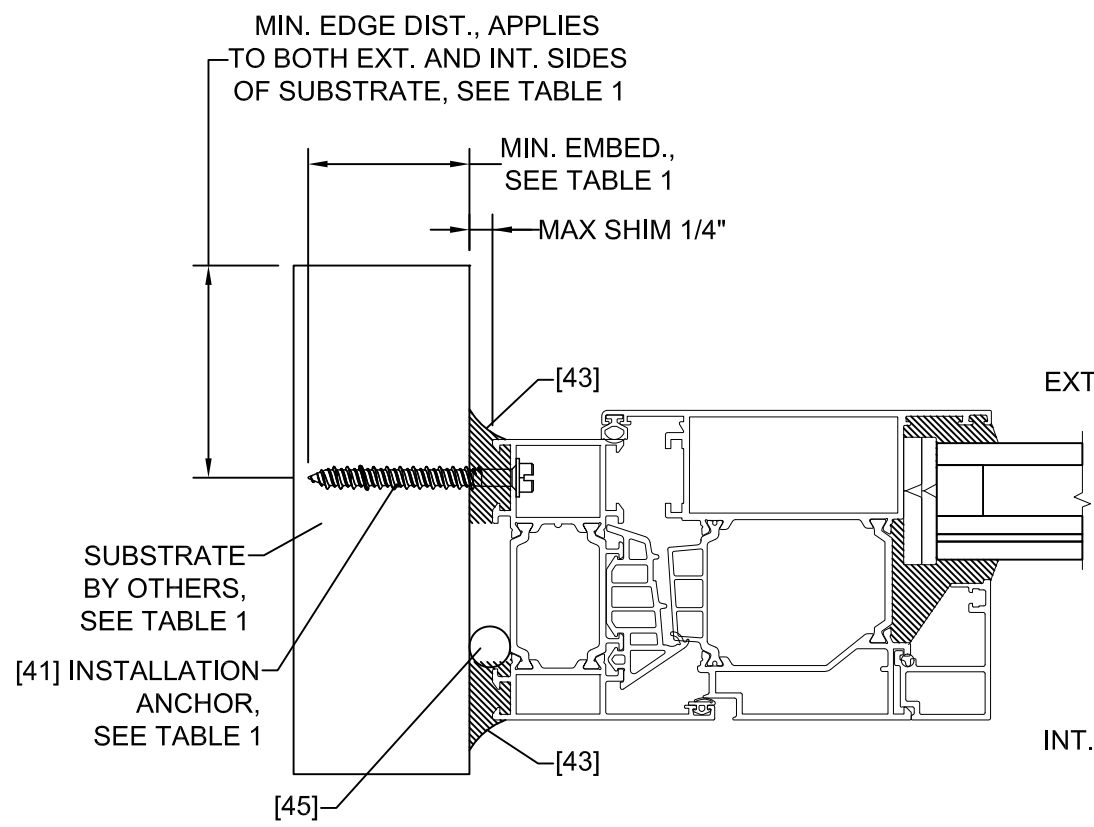

TYPICAL HEAD/JAMB INSTALLATION DETAIL

- GENERAL ANCHOR NOTES:**
1. INSTALL ONE ANCHOR AS INDICATED IN DETAIL ON SHEET 2 AT EACH LOCATION SHOWN IN THE ELEVATION ON SHEET 1.
 2. INSTALL SHIMS AT EACH ANCHOR LOCATION WHERE A GAP OF 1/16" OR GREATER EXISTS BETWEEN PRODUCT FRAME AND SUBSTRATE.
 3. SHIMS SHALL BE LOAD-BEARING (PLASTIC OR METALLIC) AND CAPABLE OF TRANSFERRING LOADS TO SUBSTRATE.
 4. SPECIFIED ANCHOR EMBEDMENT TO SUBSTRATE SHALL BE BEYOND WALL FINISH OR STUCCO, BY OTHERS. FOR ATTACHMENT TO METAL SUBSTRATES ENSURE FULL THREAD ENGAGEMENT THROUGH METAL WALL WITH MIN. 3 THREADS BEYOND.
 5. FOR MASONRY WITH WOOD BUCKS LESS THAN 1-1/2" THICK, EMBEDMENT SHALL BE BEYOND WOOD BUCKS AND INTO MASONRY. WOOD BUCKS ARE OPTIONAL WITH MASONRY INSTALLATIONS WHERE MASONRY EDGE DISTANCE CONDITIONS ARE MET WITH NO BUCKS. WOOD BUCKS 1-1/2" THICK OR GREATER SHALL HAVE EMBEDMENT INTO THE WOOD BUCKS.
 6. ENSURE 4" MIN. ON-CENTER SPACING BETWEEN ANY TWO INSTALLATION ANCHORS.

TABLE 1: INSTALLATION ANCHOR REQUIREMENTS TABLE
NOTE: ALL ANCHORS ARE PAN HEAD OR HEX WASHER HEAD

SUBSTRATE TYPE	ANCHOR TYPE	MIN. EMBED.	MIN. EDGE DISTANCE
CONCRETE (3.05 KSI MIN)	1/4" DEWALT ULTRACON+	1-3/8"	1"
GROUT-FILLED CMU (ASTM C-90)	1/4" DEWALT ULTRACON+	1-3/4"	1"
HOLLOW CMU (ASTM C-90)	1/4" DEWALT ULTRACON+	1-1/4"	2-1/2"
2X MIN. SPRUCE-PINE-FIR WOOD (G=0.42 MIN.)	1/4" DEWALT ULTRACON+	1-3/8"	1"
16 GAUGE (0.060") MIN. STEEL STUD, 33KSI YIELD MIN., OR 1/8" ALUM. 6063-T5 MIN.	1/4"-14 HILTI KWIK-FLEX OR ITW TEKS SELF-DRILLING SCREW	FULL + 3 THREADS	1/2"

LUXVIEW

Sheet Title:
ANCHORAGE, GLAZING

LUXVIEW PROPRIETARY
COPYRIGHT 2023 LUXVIEW LLC

12605 Old Hickory Blvd Ste. 100
Antioch, TN 37013
615-200-7843

Dwg: FPA-SWING77
Sheet: 2 of 3

Date:
6/26/2023

Rev: A
Scale: NTS

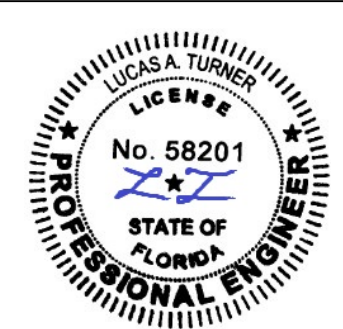

10/23/2023
Lucas A. Turner, P.E.
FL PE #58201
Turner Engineering
& Consulting, Inc.
2428 Old Natchez Trc Trl
Camden, TN 38320
Ph. 941-380-1574

Tag	Part #	Part Name	Material Type
1	LUX-HD77-0009	Perimeter Frame	6060-T66 Alum w/ Polyamide Strut
4	LUX-HD77-0002	Threshold	6060-T66 Alum w/ Polyamide Strut
5	LUX-HD77-0003	Threshold Cover	6060-T66 Alum
6	LUX-HD77-0004	Adapter	6060-T66 Alum w/ Polyamide Strut
7	LUX-HD77-0005	Sash Frame	6060-T66 Alum w/ Polyamide Strut
9	LUX-GZB-0003	Glazing Bead	6060-T66 Alum
10	LUX-CLT-0005	Frame Cleat Secondary	Cast Aluminum
11	LUX-CLT-0006	Frame Cleat Primary	Cast Aluminum
12	LUX-CLT-0016	Sash Cleat Primary	Cast Aluminum
13	LUX-CLT-0017	Sash Cleat Secondary	Cast Aluminum
14	LUX-CLT-0018	Alignment Corner	Aluminum
15	LUX-CLT-0007	Alignment Corner	Aluminum
19	LUX-GKT-0010	Central Gasket	EPDM
21	LUX-GKT-0011	Bubble Gasket	EPDM
22	LUX-GKT-0012	Gasket for LUX-77052	EPDM
23	LUX-CLT-0019	Vulcanized Corner	PVC
24	LUX-PRK-0008	Glazing Wedge 5mm	Polyamide
25	LUX-COV-0002	Low Threshold Cap Set	Polyamide
26	LUX-COV-0003	Cap for LUX-77052 Set	Polyamide
28	LUX-HIN-0002	Euro Groove HD Hinge by Luxview	Aluminum w/ Stainless Steel Pin
29	LUX-HDL-0010	Door Handle Set by Luxview	Cast Aluminum
31	LUX-HDL-0011	Locking Plate by Luxview	Cast Aluminum
32	LUX-HDL-0012	Locking point by Luxview	Cast Aluminum w/ Stainless Steel Pin
33	LUX-HDL-0013	Lock by Luxview	Stainless Steel
34	LUX-HDL-0014	Counter Plate by Luxview	Cast Aluminum
35	LUX-HDL-0015	110mm Cylinder by Luxview	Stainless Steel
40	LUX-FST-0009	Screws	18-8 Stainless Steel
41	-	Installation Anchor, See Table 1	
42	DOW995	Silicone	Silicone
43	DOW795	Silicone	Silicone
44	LUX-GKT-0013	Frame to Sash Gasket	EPDM
45	NOMSRSP38B300	3/8" Open Cell Backer Rod	Closed Cell Foam
46	LUX-FST-0010	8x1 Flat Head	18-8 Stainless Steel

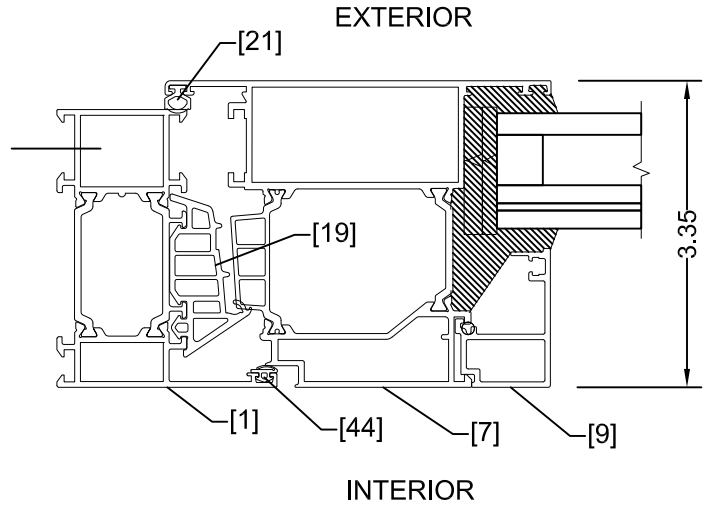

SECTION A
TYPICAL HEAD/JAMB SECTION DETAIL

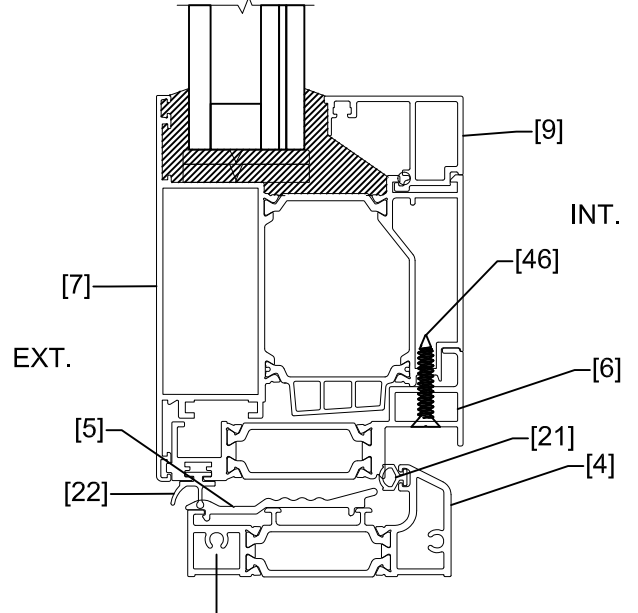

SECTION B
TYPICAL SILL SECTION DETAIL

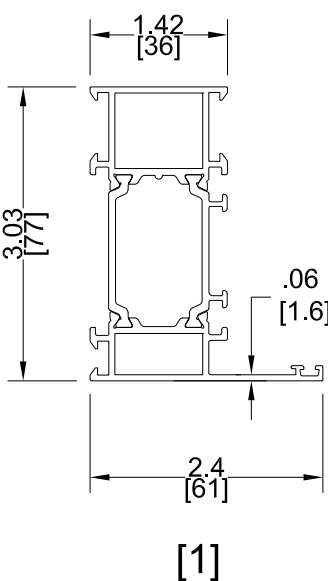

[1]

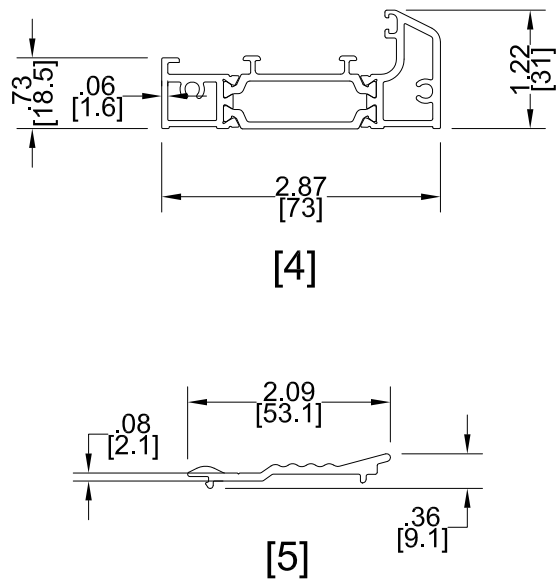

[4]

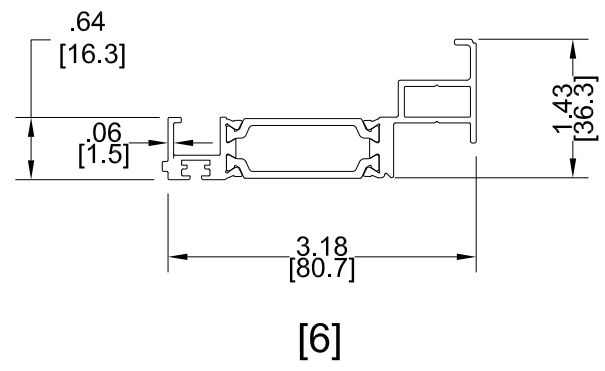

[6]

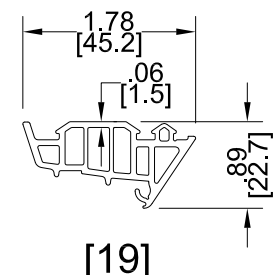

[19]

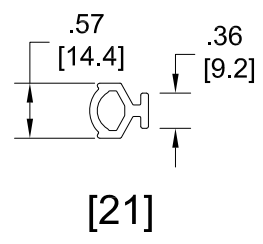

[21]

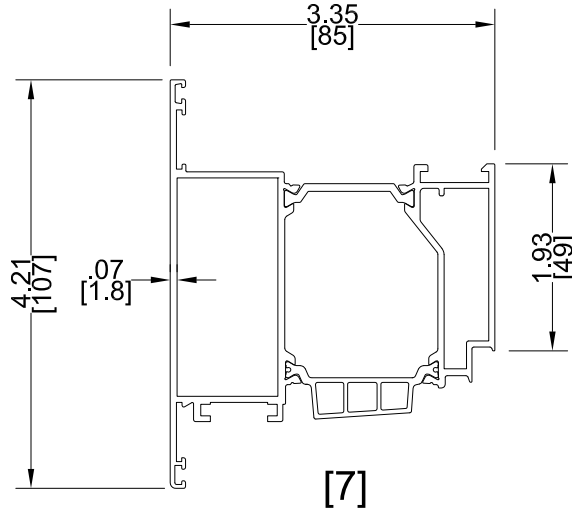

[7]

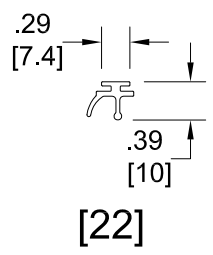

[22]

LUXVIEW

12605 Old Hickory Blvd Ste. 100
Antioch, TN 37013
615-200-7843

Sheet Title:
DETAILS, BOM, PART DRAWINGS

Date:
6/26/2023

LUXVIEW PROPRIETARY
COPYRIGHT 2023 LUXVIEW LLC

Dwg: FPA-SWING77
Sheet: 3 of 3

Rev: A
Scale: NTS



10/23/2023
Lucas A. Turner, P.E.
FL PE #58201
Turner Engineering
& Consulting, Inc.
2428 Old Natchez Trc Trl
Camden, TN 38320
Ph. 941-380-1574