



MIAMI-DADE COUNTY
PRODUCT CONTROL SECTION
 11805 SW 26 Street, Room 208
 Miami, Florida 33175-2474
 T (786) 315-2590 F (786) 315-2599
www.miamidade.gov/building

DEPARTMENT OF REGULATORY AND ECONOMIC RESOURCES (RER)
 BOARD AND CODE ADMINISTRATION DIVISION
NOTICE OF ACCEPTANCE (NOA)

Custom Window Systems, Inc.
 1900 SW 44th Avenue
 Ocala, FL 34474

SCOPE:

This NOA is being issued under the applicable rules and regulations governing the use of construction materials. The documentation submitted has been reviewed and accepted by Miami-Dade County RER - Product Control Section to be used in Miami Dade County and other areas where allowed by the Authority Having Jurisdiction (AHJ).

This NOA shall not be valid after the expiration date stated below. The Miami-Dade County Product Control Section (In Miami-Dade County) and/ or the AHJ (in areas other than Miami-Dade County) reserve the right to have this product or material tested for quality assurance purposes. If this product or material fails to perform in the accepted manner, the manufacturer will incur the expense of such testing and the AHJ may immediately revoke, modify, or suspend the use of such product or material within their jurisdiction. RER reserves the right to revoke this acceptance if it is determined by Miami-Dade County Product Control Section that this product or material fails to meet the requirements of the applicable building code.

This product is approved as described herein and has been designed to comply with the Florida Building Code, including the High Velocity Hurricane Zone.

DESCRIPTION: Series “CWS-310 (Fin Frame)” Aluminum Single Hung Window - N.I.

APPROVAL DOCUMENT: Drawing No. **CWS-1225**, titled “CWS 310 Aluminum Single Hung Fin Frame Non-Impact Window”, sheets 1 through 5 of 5, dated 11/17/23, prepared by the manufacturer, signed and sealed by Thomas J. Sotos, P.E., bearing the Miami-Dade County Product Control Revision stamp with the Notice of Acceptance number and expiration date by the Miami-Dade County Product Control Section.

MISSILE IMPACT RATING: None

LABELING: Each unit shall bear a permanent label with the manufacturer's name or logo, city, state, series, and following statement: "Miami-Dade County Product Control Approved", unless otherwise noted herein.

RENEWAL of this NOA shall be considered after a renewal application has been filed and there has been no change in the applicable building code negatively affecting the performance of this product.

TERMINATION of this NOA will occur after the expiration date or if there has been a revision or change in the materials, use, and/ or manufacture of the product or process. Misuse of this NOA as an endorsement of any product, for sales, advertising or any other purposes shall automatically terminate this NOA. Failure to comply with any section of this NOA shall be cause for termination and removal of NOA.

ADVERTISEMENT: The NOA number preceded by the words Miami-Dade County, Florida, and followed by the expiration date may be displayed in advertising literature. If any portion of the NOA is displayed, then it shall be done in its entirety.

INSPECTION: A copy of this entire NOA shall be provided to the user by the manufacturer or its distributors and shall be available for inspection at the job site at the request of the Building Official.

This NOA **revises NOA No. 23-1017.07** and consists of this page 1 and evidence pages E-1, E-2 and E-3, as well as approval document mentioned above.

The submitted documentation was reviewed by **Manuel Perez, P.E.**

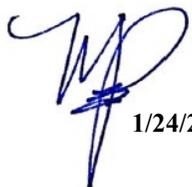

 1/24/24

NOA No. 24-0116.15
 Expiration Date: July 07, 2025
 Approval Date: February 01, 2024
 Page 1

NOTICE OF ACCEPTANCE: EVIDENCE SUBMITTED

1. EVIDENCE SUBMITTED UNDER PREVIOUS NOA's

A. DRAWINGS

1. Manufacturer's die drawings and sections.
(Submitted under NOA No. 05-0324.06)
2. Drawing No. **L7600-0402**, titled "SH-7600 Single Hung Fin Window", sheets 1 through 5 of 5, dated 09/20/04, with revision **H** dated 10/11/23, prepared by manufacturer, signed and sealed by Thomas J. Sotos, P.E.
(Submitted under NOA No. 23-1017.07)

B. TESTS

1. Test reports on: 1) Uniform Static Air Pressure Test, Loading per FBC, TAS 202-94
2) Large Missile Impact Test per FBC, TAS 201-94
3) Cyclic Wind Pressure Loading per FBC, TAS 203-94
along with marked-up drawings and installation diagram of a series SH-7700 aluminum single hung window, prepared by Hurricane Engineering & Testing, Inc., Test Reports No. **HETI-23-8048** and **HETI-23-8049**, dated 07/24/23, signed and sealed by Ram N. Tewari, P.E.
(Submitted under NOA No. 23-1017.07)
2. Test reports on: 1) Air Infiltration Test, per FBC, TAS 202-94
2) Uniform Static Air Pressure Test, Loading per FBC TAS 202-94
3) Water Resistance Test, per FBC, TAS 202-94
4) Forced Entry Test, per FBC 2411.3.2.1, and TAS 202-94
along with marked-up drawings and installation diagram of an aluminum single hung window-fin mounted, prepared by Fenestration Testing Laboratories, Inc., Test Report No. **FTL-5284**, dated on 09/14/07, and addendum letter dated 07/21/08, all signed and sealed by Michael R. Wenzel, P.E.
(Submitted under NOA No.07-1029.05)
3. Test reports on: 1) Air Infiltration Test, per FBC, TAS 202-94
2) Uniform Static Air Pressure Test, Loading per FBC TAS 202-94
3) Water Resistance Test, per FBC, TAS 202-94
4) Forced Entry Test, per FBC 2411.3.2.1, and TAS 202-94
along with marked-up drawings and installation diagram of aluminum single hung windows - (fin/flange mounted), prepared by Fenestration Testing Laboratory, Inc., Test Reports No. **FTL-4324**, **FTL-4350**, **FTL-4351**, **FTL-4346**, **FTL-4363**, **FTL-4323**, **FTL-4406** and **FTL-4405**, all dated 11/08/04 and 11/12/04, signed and sealed by Edmundo J. Largaespada, P.E.
(Submitted under NOA No.05-0324.06)

Manuel Perez, P.E.
Product Control Examiner
NOA No. 24-0116.15
Expiration Date: July 07, 2025
Approval Date: February 01, 2024

Custom Window Systems, Inc.

NOTICE OF ACCEPTANCE: EVIDENCE SUBMITTED

1. EVIDENCE SUBMITTED UNDER PREVIOUS NOA's (CONTINUED)

C. CALCULATIONS

1. Anchor verification calculations and structural analysis, complying with FBC, dated 08/04/09, prepared by manufacturer, signed and sealed by Thomas J. Sotos, P.E.
(Submitted under NOA No. 09-0720.06)
2. Glazing complies with ASTM E1300-04/09

D. QUALITY ASSURANCE

1. Miami-Dade Department of Regulatory and Economic Resources (RER).

E. MATERIAL CERTIFICATIONS

1. None.

F. STATEMENTS

1. Statement letter of conformance, complying with **FBC 8th Edition (2023)**, dated October 11, 2023, issued by the manufacturer, signed and sealed by Thomas J. Sotos, P.E.
(Submitted under NOA No. 23-1017.07)
2. Statement letter of no financial interest, dated October 11, 2023, issued by the manufacturer, signed and sealed by Thomas J. Sotos, P.E.
(Submitted under NOA No. 23-1017.07)
3. Proposal No. **23-0461R** issued by Product Control Section, dated June 13, 2023, and revised on June 16, 2023, signed by Manuel Perez, P.E.
(Submitted under NOA No. 23-1017.07)
4. Laboratory compliance letter for Test Report No. **FTL-5284**, issued by Fenestration Testing Laboratory, Inc., dated 09/14/07, signed and sealed by Michael R. Wenzel, P.E.
(Submitted under NOA No. 07-1029.05)
5. Laboratory compliance letter for Test Reports No. **FTL-4324, FTL-4350, FTL-4346, FTL-4363, FTL-4323, FTL-4406** and **FTL-4405**, issued by Fenestration Testing Laboratory, Inc., all dated 11/08/04 and 11/12/04, all signed and sealed by Edmundo J. Largaespada, P.E.
(Submitted under NOA No.05-0928.02)

G. OTHERS

1. Notice of Acceptance No. **20-0814.06**, issued to Lawson Industries, Inc. for their Series "SH-7600 (Fin Frame)" Aluminum Single Hung Window – N.I., approved on 10/15/20 and expiring on 07/07/25.

Manuel Pérez, P.E.
Product Control Examiner
NOA No. 24-0116.15
Expiration Date: July 07, 2025
Approval Date: February 01, 2024

Custom Window Systems, Inc.

NOTICE OF ACCEPTANCE: EVIDENCE SUBMITTED

2. NEW EVIDENCE SUBMITTED

A. DRAWINGS

1. Drawing No. **L7600-0402**, titled “SH-7600 Single Hung Fin Window”, sheets 1 through 5 of 5, dated 09/20/04, with revision **H** dated 10/11/23, prepared by manufacturer, signed and sealed by Thomas J. Sotos, P.E.

B. TESTS

1. None.

C. CALCULATIONS

1. None.

D. QUALITY ASSURANCE

1. Miami-Dade Department of Regulatory and Economic Resources (RER)

E. MATERIAL CERTIFICATIONS

1. None.

F. STATEMENTS

1. Statement letter of conformance, complying with **FBC 8th Edition (2023)**, dated December 18, 2023, issued by the manufacturer, signed and sealed by Thomas J. Sotos, P.E.
2. Statement letter of no financial interest, dated December 18, 2023, issued by the manufacturer, signed and sealed by Thomas J. Sotos, P.E.
3. Private Labeling Agreement document in conformance to Product Control guidelines dated 01/11/24, signed by Kevin E. Pine, vice president.

F. OTHERS

1. Notice of Acceptance No. **23-1017.07**, issued to Lawson Industries, Inc. for their Series “SH-7600 (Fin Frame)” Aluminum Single Hung Window – N.I., approved on 11/16/23 and expiring on 07/07/25.

Manuel Pérez, P.E.
Product Control Examiner
NOA No. 24-0116.15
Expiration Date: July 07, 2025
Approval Date: February 01, 2024



1900 SW 44TH AVE.
OCALA, FLORIDA 34474
WWW.CWS.CC

**CWS 310 SINGLE HUNG
ALUMINUM FIN FRAME
NON-IMPACT WINDOW**

NO.	DESCRIPTION:	BY:	DATE:
A			

THOMAS J. SOTOS
PROFESSIONAL ENGINEER
FL LIC. # 55225
SEAL

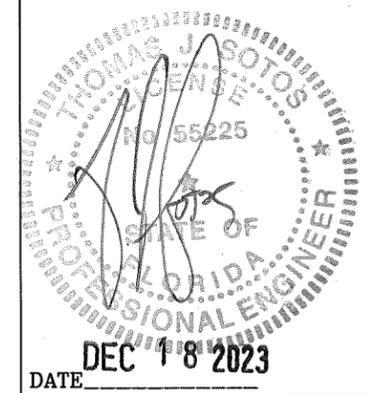

DATE: **DEC 18 2023**
SHEET DESCRIPTION:
APPROVED ELEVATIONS,
CONFIGURATIONS AND
NOTES

DRAWN BY: NELSON ERAZO
DATE: 11/17/2023

REV. BY: _____
DATE: _____

DWG #: CWS-1225
REV #:

SCALE: AS NOTED
SHEET 1 OF 5

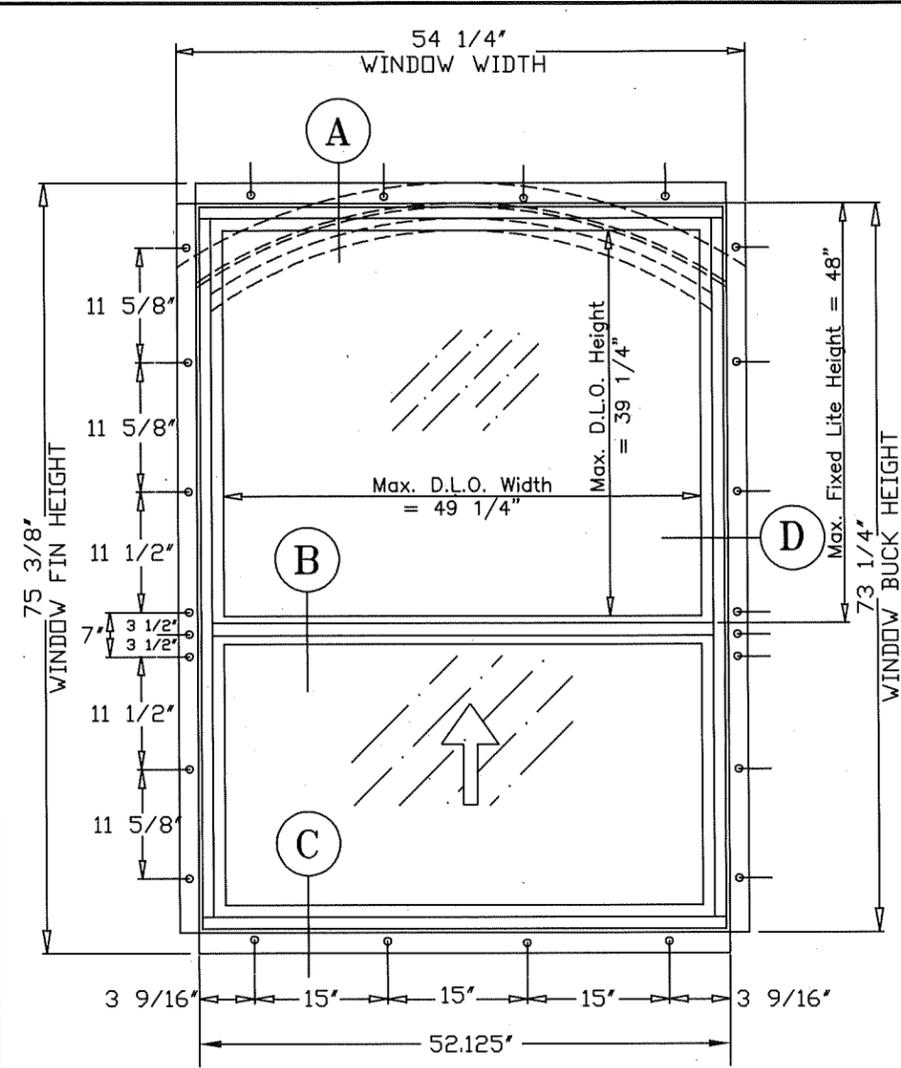

**UNEQUAL LITE VIEW WINDOW
ELEVATION**
(SEE TABLE V-1 & V-2 FOR DESIGN PRESSURE)

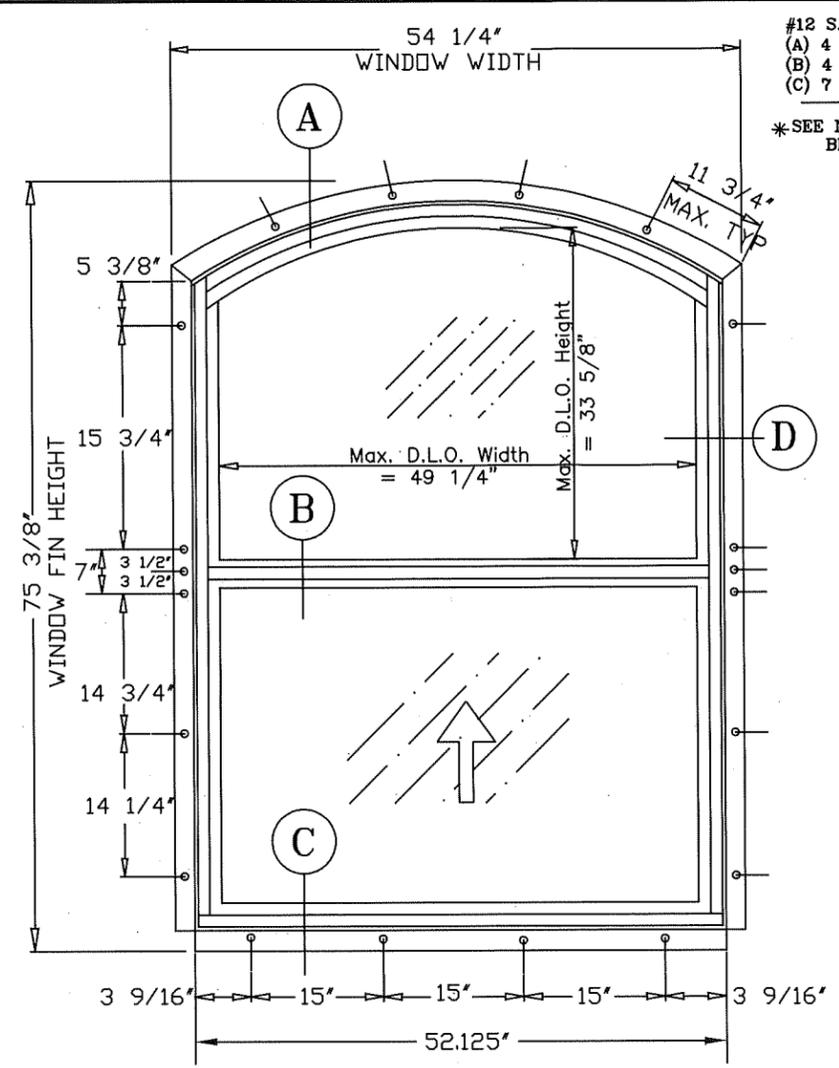

**RADIUS HEAD EQUAL LITE WINDOW
ELEVATION**

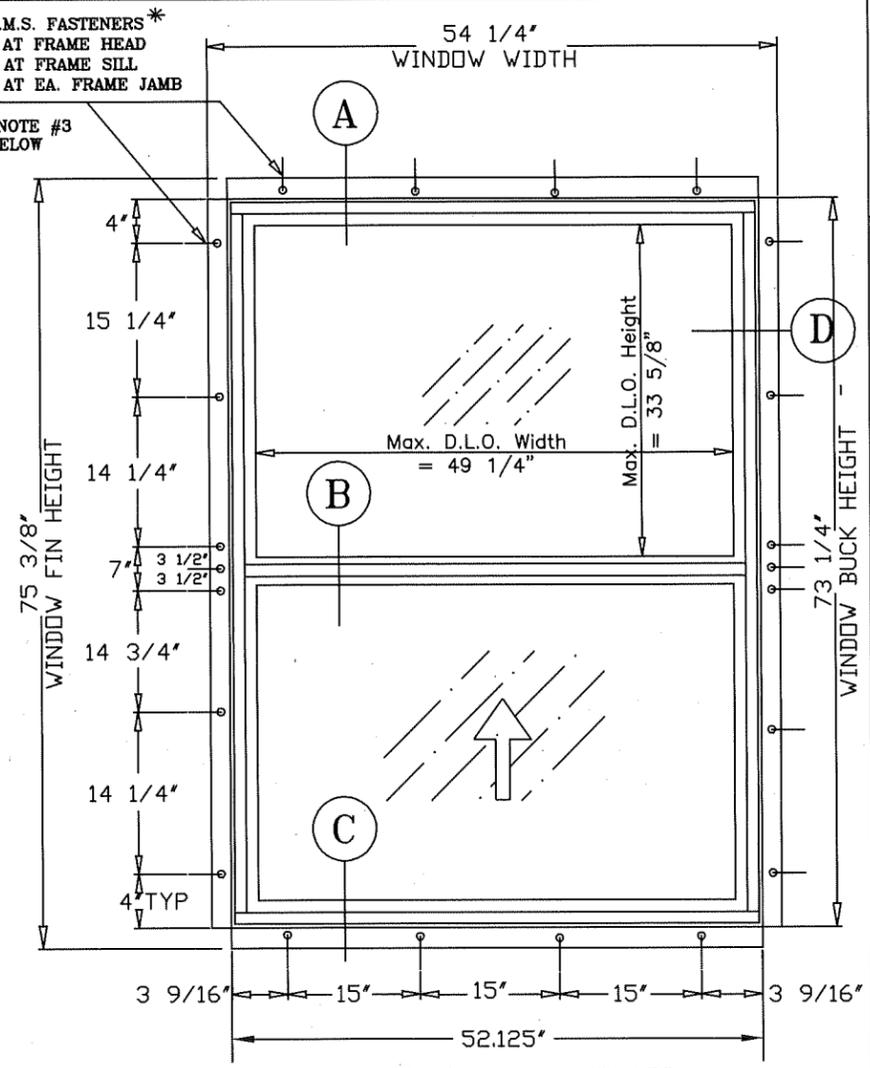

**EQUAL LITE WINDOW
ELEVATION**

#12 S.M.S. FASTENERS*
(A) 4 AT FRAME HEAD
(B) 4 AT FRAME SILL
(C) 7 AT EA. FRAME JAMB
*SEE NOTE #3 BELOW

CWS 310 ALUMINUM FIN FRAME NON-IMPACT SINGLE HUNG WINDOW

NOTES:

- THIS WINDOW SYSTEM IS DESIGNED AND TESTED TO COMPLY WITH THE REQUIREMENTS OF THE FLORIDA BUILDING CODE (2020-7th Edition & 2023-8th Edition) AND ASTM 1300-09. THIS PRODUCT IS NOT IMPACT RESISTANT. WINDOWS ARE TO BE PROTECTED WITH A MIAMI-DADE COUNTY APPROVED IMPACT RESISTANT SHUTTER.
- 1 X OR 2 X WOOD BUCKS SHALL BE INSTALLED AND ANCHORED SO THAT THE BUILDING RESISTS THE SUPERIMPOSED LOADS IN ACCORDANCE WITH REQUIREMENTS OF F.B.C. & TO BE REVIEWED BY BUILDING OFFICIAL.
- ANCHORS SHOWN ABOVE ARE AS PER TEST UNITS. EXTERIOR ANCHOR SPACINGS WILL VARY WITH UNIT DIMENSIONS, AND THE NUMBER OF ANCHORS REQUIRED, AS SPECIFIED ON THE LOAD TABLES AT SHEET 3 & 4.
- ANCHOR CONDITIONS NOT DESCRIBED IN THESE DRAWING'S ARE TO BE ENGINEERED ON A SITE SPECIFIC BASIS, UNDER SEPARATE APPROVAL AND TO BE REVIEWED BY BUILDING OFFICIAL.
- RADIUS HEAD WINDOWS ARE QUALIFIED FOR USE WITH ALL GLASS TYPES TABULATED HEREIN. HEREIN.
- VIEW WINDOWS ARE QUALIFIED FOR USE WITH 3/16" ANNEALED & 3/16" TEMPERED GLASS USING THE HEAVY DUTY MEETING RAIL ONLY.
- SEE SHEET #5 FOR SASH LOCK OPTIONS & NOTES.
- SEE SHEET #4 FOR GLAZING DETAILS & OPTIONS. (REFER TO SHEETS 3, & 4 FOR DESIGN PRESSURES.
- WOOD OPENING SHALL BE PROTECTED WITH AN APPROVED MOISTURE RESISTANT BARRIER (BY OTHERS), PRIOR TO WINDOW INSTALLATION. (SEE SHEET #2 FOR DETAIL & NOTES.
- APPROVAL APPLIES TO SINGLE UNITS, OR MULTIPLE UNITS AND MAY BE MULLED VERTICALLY OR HORIZONTALLY.
- MULLING SINGLE HUNG WINDOWS WITH OTHER TYPES OF MIAMI-DADE COUNTY APPROVED WINDOWS USING A MIAMI-DADE COUNTY APPROVED MULLION IN BETWEEN ARE ACCEPTABLE BUT THE LOWER PRESSURE FROM THE WINDOWS OR MULLION APPROVAL WILL APPLY TO THE ENTIRE MULLED SYSTEM.
- SEE SHEET # 5 FOR MULLION/METAL ATTACHMENT DETAILS & NOTES.

WINDOWS ARE TO BE PROTECTED WITH
MIAMI DADE COUNTY APPROVED IMPACT
RESISTANT SHUTTERS

PRODUCT REVISED
As complying with the Florida
Building Code
NOA-No. **24-0116.15**
Expiration Date: **07/07/2025**
By: *Manuel Perez*
Miami-Dade Product Control

**CWS 310 SINGLE HUNG
ALUMINUM FIN FRAME
NON-IMPACT WINDOW**

NO.	DESCRIPTION	BY	DATE
A			

THOMAS J. SOTOS
PROFESSIONAL ENGINEER
FL LIC. # 55225
SEAL

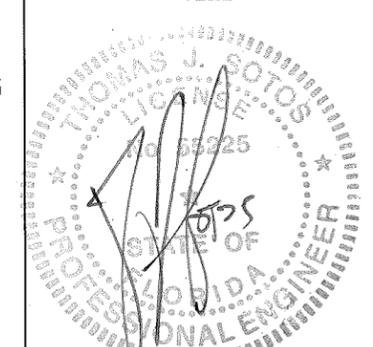

DATE: DEC 18 2023

SHEET DESCRIPTION:
CROSS SECTIONAL DETAILS
FOR STANDARD AND HEAVY
DUTY MEETING RAILS

DRAWN BY: NELSON ERAZO
DATE: 11/17/2023

REV. BY: DATE:

DWG #: CWS-1225
REV #:

SCALE: AS NOTED
SHEET 2 OF 5

WOOD BUCKS NOT BY CWS
MUST SUSTAIN IMPOSED LOADS

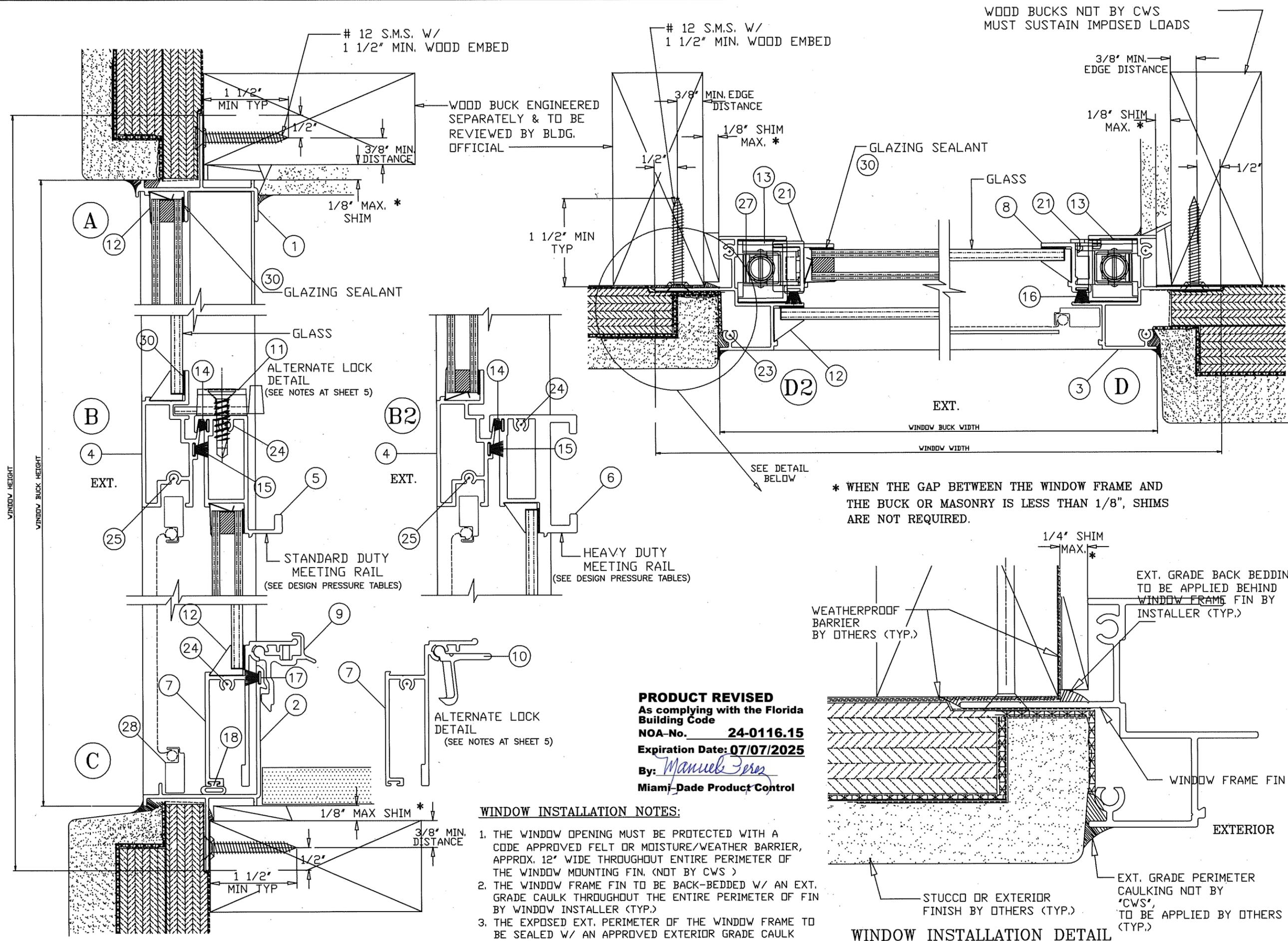

WINDOW HEIGHT

WINDOW BUCK HEIGHT

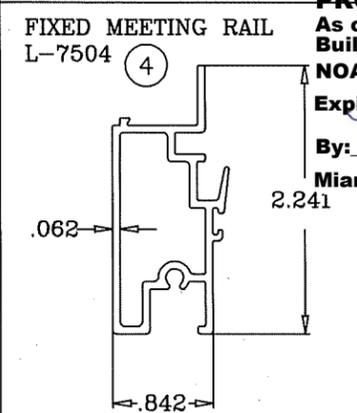
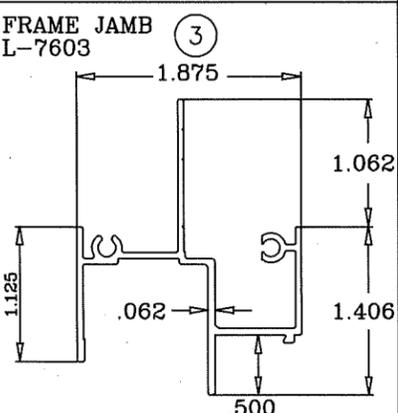
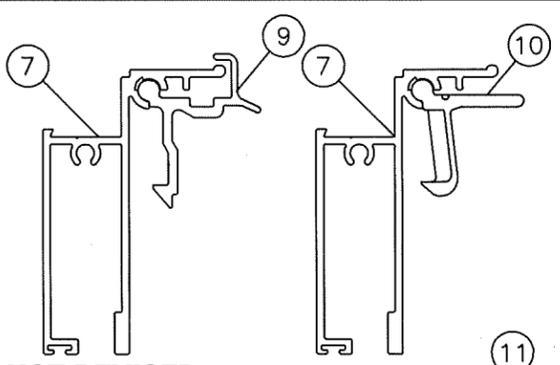
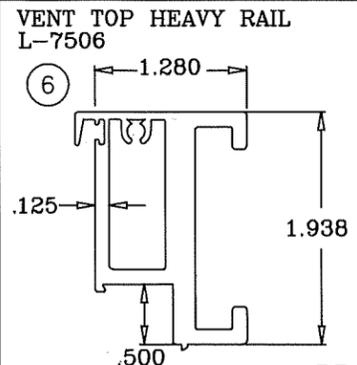
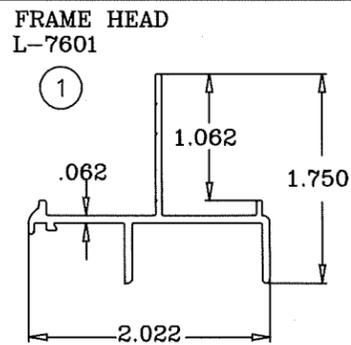

PRODUCT REVISED
 As complying with the Florida Building Code
 NOA-No. **24-0116.15**
 Expiration Date: **07/07/2025**
 By: *Manuel Perez*
 Miami-Dade Product Control

Lock Notes:
 1. BOTH EXTRUDED ALUMINUM AND PLASTIC LIFT HANDLE LOCKS ARE QUALIFIED FOR USE ON ALL WINDOWS.
 2. THE CAM LOCK IS QUALIFIED FOR USE ON ALL ANNEALED WINDOWS AND 1/8" TEMPERED WINDOWS ONLY.
 3. TWO (2) LOCKS ARE REQUIRED PER EACH SASH.

LOCK (LATCH AND SWEEP) OPTIONS

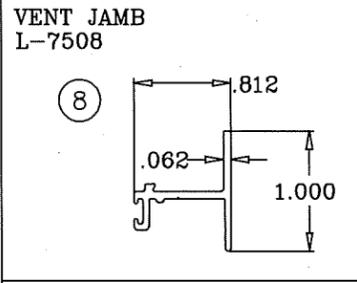
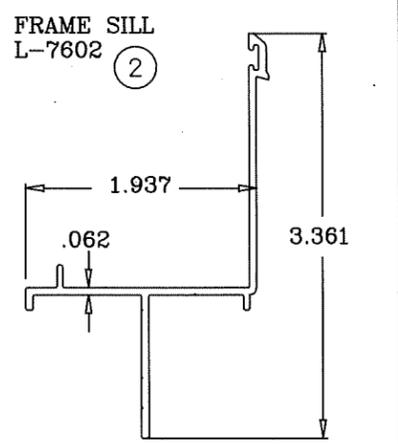
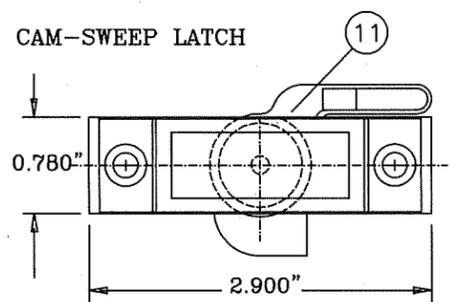

* NOTE:
 ALL DIMENSIONS ARE INCHES UNITS

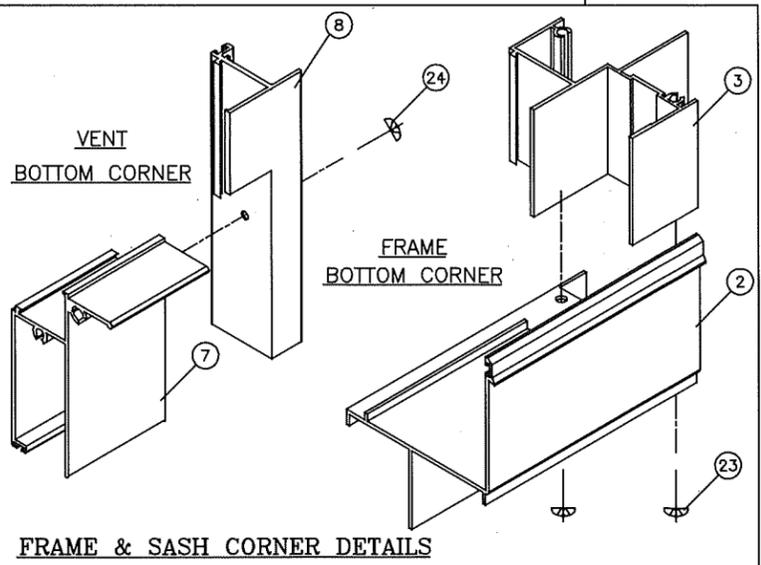
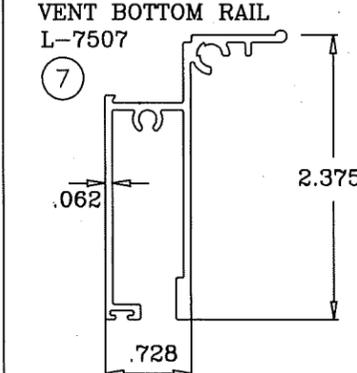
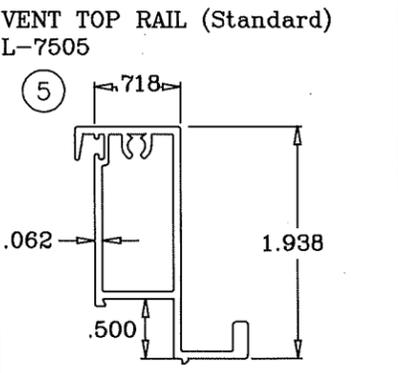
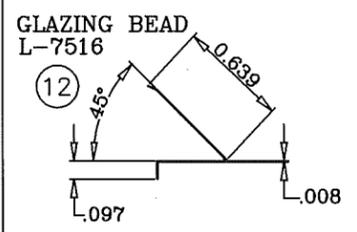
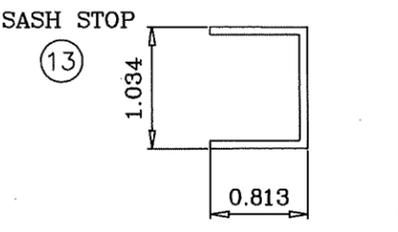

CWS 310 FIN WINDOW BILL OF MATERIALS					
ITEM #	PART #	DRWG. #	REQD.	DESCRIPTION	REMARKS
1	L-7601	LII-123	1	FRAME HEAD	6063-T6 ALUMINUM
2	L-7602	LII-122	1	FRAME SILL	6063-T6 ALUMINUM
3	L-7603	LII-128	2	FRAME JAMB	6063-T6 ALUMINUM
4	L-7504	LII-129	1	FIXED MEETING RAIL	6005-T5 ALUMINUM
5	L-7505	LII-125	1	VENT TOP RAIL STD. DUTY	6005-T5 ALUMINUM
6	L-7506	LII-126	1	VENT TOP RAIL HVY DUTY	6005-T5 ALUMINUM
7	L-7507	LII-136	1	VENT BOTTOM RAIL	6005-T5 ALUMINUM
8	L-7508	LII-124	1	VENT JAMB	6063-T5 ALUMINUM
9	*	*	2	VENT LATCH / LIFT LOCK	6063-T6 ALUMINUM
10	*	*	2	VENT LATCH / LIFT LOCK	INJECTED MOLDED
11	*	*	2	VENT LATCH / SWEEP	DIE CAST
12	L-7516	*	AS REQD.	GLAZING BEAD	ROLL FORMED ALUMINUM
13	*	*	2	VENT/SASH STOP	1 PER JAMB
14	*	SCHLEGEL	AS REQD.	TOP RAIL WEATHERSTRIP	.187' X 150' PILE
15	*	ULTRAFAB	AS REQD.	FXD. RAIL WEATHERSTRIP	.187' X 250' FIN SEAL
16	*	ULTRAFAB	AS REQD.	VENT JAMB WEATHERSTRIP	.187' X .280' FIN SEAL
17	*	ULTRAFAB	AS REQD.	FRAME SILL WEATHERSTRIP	.187' X .250' FIN SEAL
18	*	*	AS REQ'D.	BOTT. RAIL WEATHERSTRIP	3/8' DIA. BULB
19	*	*	2	VENT/SILL OPEN CELL PAD	1'x1'x1/2' FOAM PAD
20	*	*	2	SILL/JAMB JOINT GASKET	1/16' CLOSED CELL FOAM
21	L-7523	*	2	VENT TOP GUIDE / CAM	1 AT EACH END OF RAIL
22	L-7524	*	4	VENT JAMB FACE GUIDE	2 PER VENT JAMB
23	*	*	8	FRAME ASSEMBLY SCREWS	# 8 X 3/4' P.H. PHIL.
24	*	*	4	VENT ASSEMBLY SCREWS	# 8 X 1' P.H. PHILLIPS
25	*	*	2	FXD. MTG. RAIL SCREW	# 8 X 1' P.H. PHILLIPS
26	*	*	14	FRAME INSTALL'N SCREW	#10 X 1 1/4' F.H. / PHI.
27	L-7527	*	2	BLOCK & TACKLE BALANCE	1 PER JAMB
28	*	*	1	INSECT SCREEN	OPTIONAL
29	*	*	2	GLASS @ TOP & BOTDOM	See Detail @ Sheet 2 of 5
30	*	*	AS REQ'D	GLAZING SILICONE	See Detail @ Sheet 2 of 5
31 a	Truseal	774-25B-767	AS REQ'D	Insulated Swiggle Spacer	Black -1/4' air space
31 b	Quanex	*	AS REQ'D	Insulated SuperSpacer	Black -1/4' air space
31 c	Quanex	*	AS REQ'D	Insulated Duraseal Spacer	Black -1/4' air space

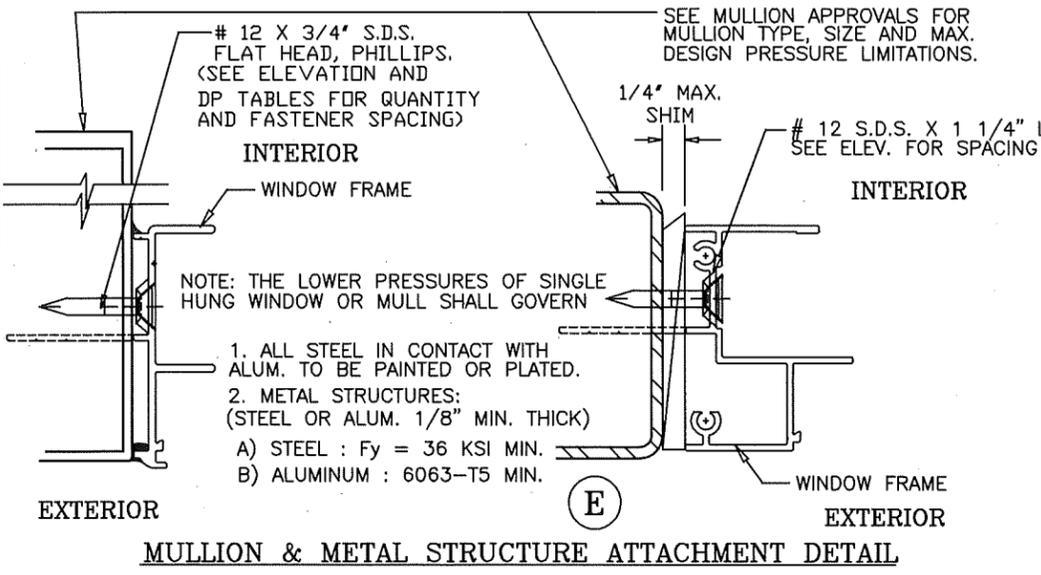

CWS 310 SINGLE HUNG ALUMINUM FIN FRAME NON-IMPACT WINDOW

NO.	DESCRIPTION	BY	DATE
A			

THOMAS J. SOTOS
 PROFESSIONAL ENGINEER
 FL LIC. # 55225

SEAL

DATE: **DEC 18 2023**

SHEET DESCRIPTION:
 BILL OF MATERIALS, EXTRUSION DETAILS, ASSEMBLY DETAILS, AND GLAZING DETAILS

DRAWN BY: NELSON ERAZO DATE: 11/17/2023

REV. BY: DATE:

DWG #: CWS-1225 REV #:

SCALE: AS NOTED SHEET 5 OF 5