

# DUCTMATE INDUSTRIES

COASTAL & INLAND HURRICANE HVAC UNIT BRACKET

VALID FOR USE INSIDE AND OUTSIDE THE HVHZ (SEE LIMITATIONS HEREIN)

NOT RATED FOR IMPACT RESISTANCE

THIS IS A NON-SITE-SPECIFIC STRUCTURAL PERFORMANCE EVALUATION. A DESIGN PROFESSIONAL SHALL BE RESPONSIBLE FOR CERTIFYING THE APPLICATION OF THIS INFORMATION TO ANY SITE-SPECIFIC LOCATION.

RICHARD NEET, P.E.  
PE# 86488 CA# 9885

DECEMBER 8, 2025

## DESIGN NOTES

1. THIS SYSTEM HAS BEEN DESIGNED TO MEET THE MAXIMUM ASD DESIGN WIND PRESSURES AS LISTED IN THE ANCHOR SCHEDULE ON SHEET 3. SEE ACCOMPANYING LIMITATIONS AND CONDITIONS:

ASD DESIGN WIND PRESSURES ARE TO BE CALCULATED ON A SITE-SPECIFIC BASIS IN ACCORDANCE WITH ASCE 7 "ABOVE GRADE SOLID SIGN" WIND PRESSURE METHODOLOGY. DESIGN PARAMETERS ARE NOT TO EXCEED THE FOLLOWING:

SITE-SPECIFIC PRESSURES SHALL BE LESS THAN OR EQUAL TO THE MAXIMUM ALLOWABLE ASD DESIGN WIND PRESSURES LISTED HEREIN IN THE ANCHOR SCHEDULE ON SHEET 3. PRESSURE VALUES IN THIS APPROVAL ARE ALLOWABLE STRESS DESIGN (ASD) PRESSURES.

## GENERAL NOTES

- THIS SYSTEM HAS BEEN DESIGNED AND SHALL BE FABRICATED IN ACCORDANCE WITH THE REQUIREMENTS OF THE FLORIDA BUILDING CODE 8TH EDITION (2023). FOR USE WITHIN AND OUTSIDE THE HIGH VELOCITY HURRICANE ZONE (HVHZ). CONTRACTOR SHALL INVESTIGATE AND CONFORM TO ALL LOCAL BUILDING CODE AMENDMENTS WHICH MAY APPLY AND GOVERN.
- MAXIMUM DIMENSIONS AND WEIGHT OF UNIT SHALL CONFORM TO SPECIFICATIONS STATED HEREIN.
- ALL MECHANICAL SPECIFICATIONS (CLEAR SPACE, TONNAGE, ETC.) SHALL BE AS PER MANUFACTURER RECOMMENDATIONS AND ARE THE EXPRESS RESPONSIBILITY OF THE CONTRACTOR. THIS DOCUMENT CERTIFIES ANCHORAGE CRITERIA FOR UNIT SIZES AND WEIGHTS THAT COMPLY WITH THE SPECIFICATIONS HEREIN AND REQUIRES THAT THE EXISTING STRUCTURE BE APPROVED BY OTHERS. REFERENCE MANUFACTURER'S UNIT DOCUMENTATION FOR DETAILED UNIT SPECIFICATIONS.
- WIND LOAD DURATION FACTOR Cd = 1.6 HAS BEEN USED FOR WOOD ANCHOR DESIGN.
- ALL FASTENERS TO BE #12 X 3/4" OR GREATER 2024-T4, 18-8 SERIES 300 NON-MAGNETIC STAINLESS STEEL, OR CADMIUM PLATED OR OTHERWISE CORROSION RESISTANT MATERIAL AND SHALL COMPLY ANY APPLICABLE FEDERAL, STATE, AND LOCAL CODES.
- BOLTS SHALL CONFORM TO A.S.T.M. A325, ANCHOR BOLTS SHALL CONFORM TO TO A.S.T.M. A307. ALL BOLTS SHALL BE HOT DIPPED GALVANIZED, OR STAINLESS STEEL & MEET THE REQUIREMENTS OF ASTM A325.
- ALL MEMBERS SHALL BE ASTM A36 FOR SHAPES OR A653 FOR SHEET STEEL (GRADE 33 MIN) WITH Fy = 36 KSI OR BETTER. THE CONTRACTOR IS RESPONSIBLE TO INSULATE ALL MEMBERS FROM DISSIMILAR MATERIALS TO PREVENT ELECTROLYSIS.
- FOR STEEL MEMBERS ALL ANCHORS SHALL BE SPACED WITH 3xDIAMETER MIN. SPACING TO ADJACENT ANCHORS AND 1.5xDIAMETER MIN. END DISTANCE.
- ELECTRICAL GROUND, WHEN REQUIRED, TO BE DESIGNED & INSTALLED BY OTHERS.
- ENGINEER SEAL AFFIXED HERETO VALIDATES STRUCTURAL DESIGN AS SHOWN ONLY. USE OF THIS SPECIFICATION BY CONTRACTOR, et. al. INDEMNIFIES & SAVES HARMLESS THIS ENGINEER FOR ALL COST & DAMAGES INCLUDING LEGAL FEES & APPELLATE FEES RESULTING FROM MATERIAL FABRICATION, SYSTEM RESULTING FROM MATERIAL FABRICATION, SYSTEM ERECTION, CONSTRUCTION PRACTICES BEYOND THAT WHICH IS CALLED FOR BY LOCAL, STATE, & FEDERAL CODES & FROM DEVIATIONS OF THIS PLAN.
- IT IS ASSUMED THAT THE ROLE OF THIS ENGINEER FOR THIS PROJECT IS THAT OF SPECIALTY ENGINEER AND NOT THE ENGINEER OF RECORD. CONSEQUENTLY, THE ARCHITECT/ENGINEER OF RECORD SHALL BE RESPONSIBLE FOR THE INTEGRITY OF ALL SUPPORTING SURFACES TO THIS DESIGN WHICH SHALL BE COORDINATED BY THE PERMITTING CONTRACTOR.
- THIS DOCUMENT IS GENERIC AND DOES NOT PERTAIN TO ANY SPECIFIC PROJECT SITE. INFORMATION CONTAINED HEREIN IS BASED ON CONTRACTOR-SUPPLIED DATA AND MEASUREMENTS. ENGINEERING EXPRESS SHALL NOT BE HELD RESPONSIBLE OR LIABLE IN ANY WAY FOR ERRONEOUS OR INACCURATE DATA OR MEASUREMENTS. DIMENSIONS ARE SHOWN TO ILLUSTRATE DESIGN FORCES AND OTHER DESIGN CRITERIA. THEY MAY VARY SLIGHTLY, BUT MUST REMAIN WITHIN THE LIMITATIONS SPECIFIED HEREIN. WORK SHALL BE FIELD VERIFIED BY OTHERS PRIOR TO CONSTRUCTION. ENGINEERING EXPRESS SHALL BE NOTIFIED AND GIVEN AN OPPORTUNITY TO REEVALUATE OUR WORK UPON DISCOVERY OF ANY INACCURATE INFORMATION PRIOR TO MODIFICATION OF EXISTING FIELD CONDITIONS AND FABRICATION AND INSTALLATION OF MATERIALS. ALTERATIONS OR ADDITIONS TO THIS DOCUMENT ARE NOT PERMITTED AND INVALIDATE OUR CERTIFICATION.
- EXCEPT AS EXPRESSLY PROVIDED HEREIN, NO ADDITIONAL CERTIFICATIONS OR AFFIRMATIONS ARE INTENDED.

### NOTE REGARDING USE OF THIS DOCUMENT & USE OUTSIDE FLORIDA:

THIS IS A NON-SITE-SPECIFIC STRUCTURAL PERFORMANCE EVALUATION. THIS PRODUCT EVALUATION IS VALID FOR USE IN FLORIDA ONLY. USE OF THIS EVALUATION REQUIRES A REVIEW & CERTIFICATION BY A LOCAL DESIGN PROFESSIONAL WHO SHALL BE RESPONSIBLE FOR THE PROPER ADAPTATION OF THIS GENERAL PERFORMANCE EVALUATION TO ANY SITE-SPECIFIC PROJECT. CONTACT THIS OFFICE AT [ENGINEERINGEXPRESS.COM/QUOTE](http://ENGINEERINGEXPRESS.COM/QUOTE) FOR ASSISTANCE WITH YOUR PROJECT-SPECIFIC NEEDS & FOR ADAPTATION & CERTIFICATION OF THIS DOCUMENT OUTSIDE OF FLORIDA.

### ENGINEER SIGNATURE & SEAL NOTICE:

\*PRINTED COPIES OF THIS DOCUMENT ARE NOT CONSIDERED SIGNED & SEALED. SIGNATURE MUST BE VERIFIED ON ANY ELECTRONIC COPIES.  
\*FOR FLORIDA STATEWIDE PRODUCT APPROVALS (FSAs) REGISTERED & APPROVED WITH THE STATE OF FLORIDA: ORIGINAL, SEALED COPIES OF APPROVED FLORIDA PRODUCT APPROVALS ARE NOT REQUIRED FOR PERMIT. SEE [ECALC.IO/SEAL](http://ECALC.IO/SEAL) TO LEARN MORE.

### VISIT [ECALC.IO/67540](http://ECALC.IO/67540)

FOR SITE-SPECIFIC DEVIATIONS & MORE INFORMATION ABOUT THIS DOCUMENT OR SCAN THIS QR CODE  
VISIT [ENGINEERINGEXPRESS.COM/STORE](http://ENGINEERINGEXPRESS.COM/STORE) FOR ADDITIONAL PLANS, REPORTS & RESOURCES



### TERMINOLOGY:

THE FOLLOWING ABBREVIATIONS MAY APPEAR IN THIS APPROVAL:

"ADDTL" FOR "ADDITIONAL", "AHJ" FOR "AUTHORITY HAVING JURISDICTION", "ALUM" FOR "ALUMINUM", "ASD" FOR "ALLOWABLE STRESS DESIGN", "EA." FOR "EACH", "E.D."/"EDGE"/"EDGE DIST." FOR "EDGE DISTANCE", "ELEV" FOR "ELEVATION", "EMBED" FOR "EMBEDMENT", "EQ"/"EQUIV." FOR "EQUIVALENT", "EXT" FOR "EXTERIOR", "FBC" FOR "FLORIDA BUILDING CODE", "G" FOR "SPECIFIC GRAVITY", "GA" FOR "GAUGE", "GALV" FOR "GALVANIZED", "GFB" FOR "GROUT-FILLED BLOCK", "GR" FOR "GRADE", "H" FOR "HEIGHT", "HOLLOW" FOR "HOLLOW BLOCK", "HORIZ" FOR "HORIZONTAL", "HVHZ" FOR "HIGH-VELOCITY HURRICANE ZONE", "INT" FOR "INTERIOR", "MAX" FOR "MAXIMUM", "MIN" FOR "MINIMUM", "N.T.S." FOR "NOT TO SCALE", "O.C." FOR "ON-CENTER", "P.E." FOR "PROFESSIONAL ENGINEER", "PERP" FOR "PERPENDICULAR", "QTY" FOR "QUANTITY", "REF." FOR "REFERENCE", "SCHED." FOR "SCHEDULE", "SDS" FOR "SELF-DRILLING SCREWS", "SMS" FOR "SHEET METAL SCREWS", "SPECS" FOR "SPECIFICATIONS", "SS" FOR "STAINLESS STEEL", "TYP." FOR "TYPICAL", "ULT" FOR "ULTIMATE LOADS", "U.N.O." FOR "UNLESS NOTED OTHERWISE", "UTS" OR "Fu" FOR "ULTIMATE TENSILE STRENGTH/STRESS", "VERT" FOR "VERTICAL", "W" FOR "WIDTH", "W/" FOR "WITH", "W/O" FOR "WITHOUT", "YS" FOR "YIELD STRENGTH", AND "Ø" FOR "DIAMETER".

VISIT [ECALC.IO/GLOSSARY](http://ECALC.IO/GLOSSARY) OR CONTACT ENGINEERING EXPRESS FOR ADDITIONAL ABBREVIATION/TERMINOLOGY CLARIFICATIONS.

PAGE INDEX	
DESCRIPTION	PAGE #
1	DESIGN & GENERAL NOTES
2	BRACKET SPECIFICATIONS
3	ANCHOR SCHEDULE

FL 47567.1

**ENGINEERING EXPRESS**

POSTAL ADDRESS:  
2234 NORTH FEDERAL HWY # 7664  
BOCA RATON, FL 33431  
ENGINEERINGEXPRESS.COM

DUCTMATE INDUSTRIES

210 FIFTH STREET  
CHARLEROI, PA 15022  
1-800-245-3188

COASTAL AND INLAND HURRICANE HVAC UNIT BRACKET  
FLORIDA BUILDING CODE EIGHTH EDITION (2023)  
FLORIDA STATEWIDE APPROVAL (FSA)

REMARKS	DRWN	CHKD	DATE
INIT ISSUE	EPR	RWN	06/10/25
REV. (ORDER 21152)	EPR	RWN	12/15/25

COPYRIGHT ENGINEERING EXPRESS®

23-67540

SCALE: NTS UNLESS NOTED

1 OF 3

12/8/2025 2:49 PM ERICREITEI z:\shared\projects\23-123-67540 2023 fbc update -coastal & inland hurricane hvac unit bracket\work\2023 fbc\isa\drawings & ca\2023-67540q - f47567.1 - dwg.dwg

# COASTAL & INLAND HURRICANE HVAC UNIT BRACKET

RICHARD NEET, P.E.  
PE# 86488 CA# 9885

DECEMBER 8, 2025



FL

## SYSTEM CONFIGURATIONS

PART NO.	A DIM.	B DIM. (MAX)
AIRBRACE	30"	36"
AIRBRACE45S	36"	45"
AIRBRACE55S	48"	55"

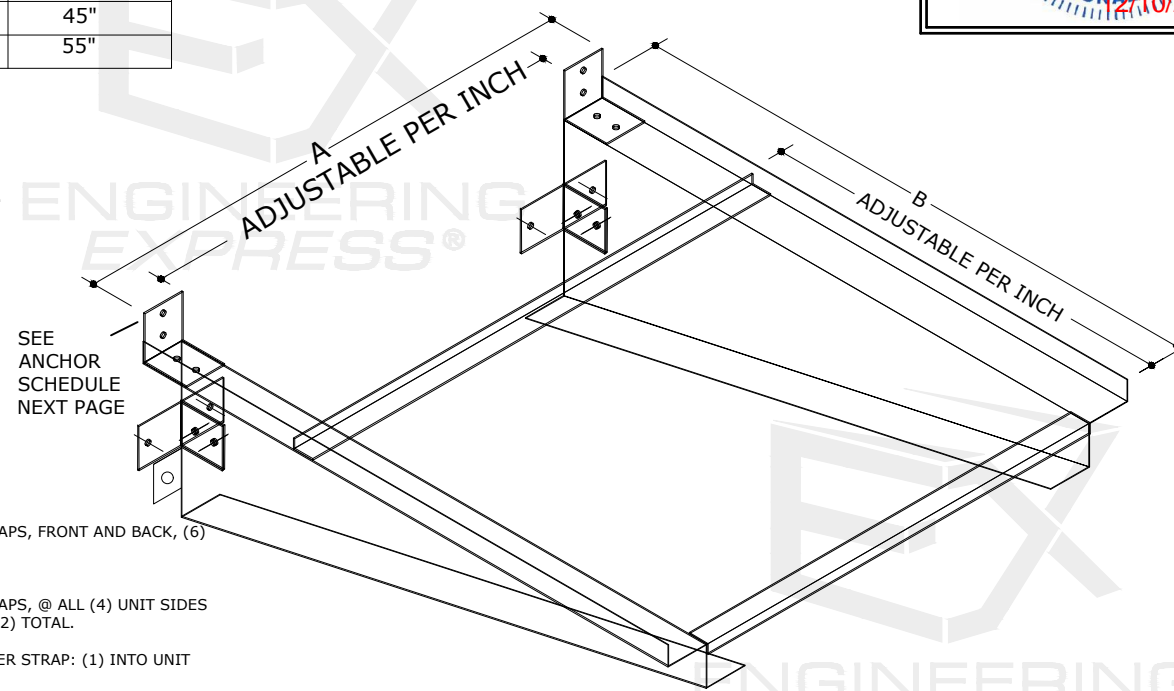
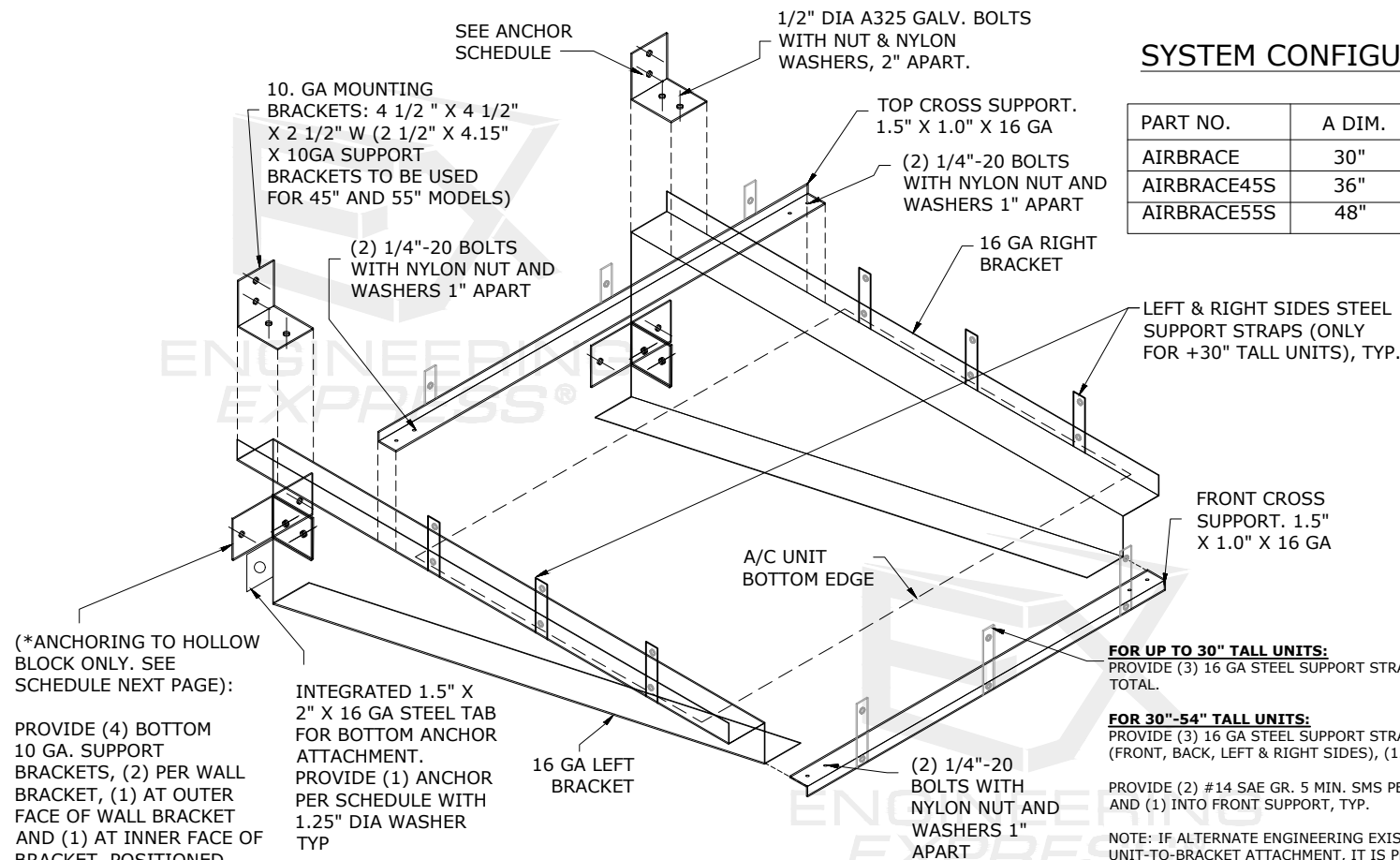

1 HVAC MOUNTING BRACKET  
2 SCALE: NTS  
EXPLODED VIEW

2 HVAC MOUNTING BRACKET  
2 SCALE: NTS  
ISOMETRIC VIEW

BRACKETS SHALL BE 4-1/2" X 4-1/2" X 2-1/2" W (2-1/2" X 4.15" X 10GA FOR 45" AND 55" WALL BRACKET MODELS).

ATTACH SUPPORT BRACKET TO HOLLOW BLOCK HOST BY OTHERS WITH (1) ANCHOR PER SUPPORT BRACKET, TYP. SEE ANCHOR SCHEDULE NEXT PAGE.

ATTACH SUPPORT BRACKETS TOGETHER THROUGH THE WALL BRACKET WITH (2) 1/2" DIA A325 GALV. BOLTS WITH NUT & NYLON WASHERS, 2" APART, TYP.

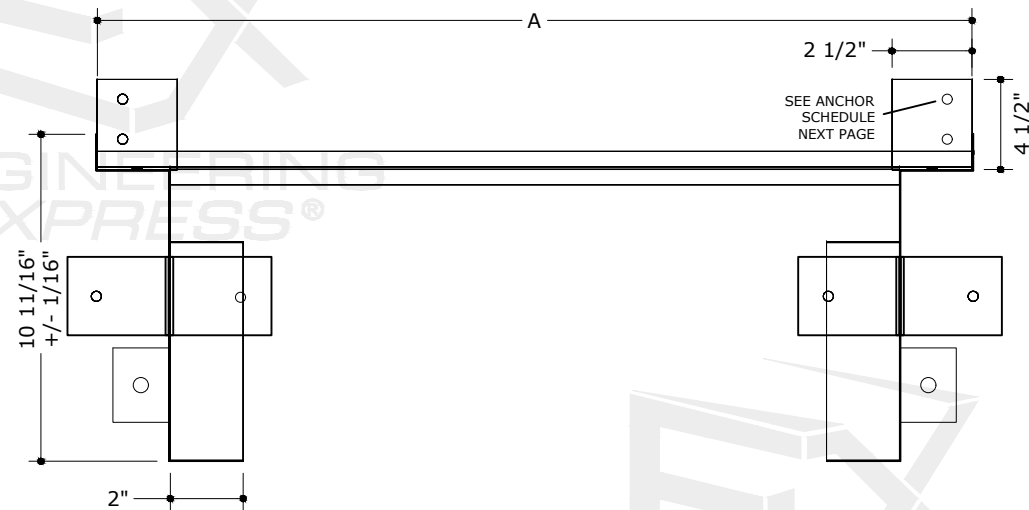

3 HVAC MOUNTING BRACKET  
2 SCALE: NTS  
FRONT ELEVATION

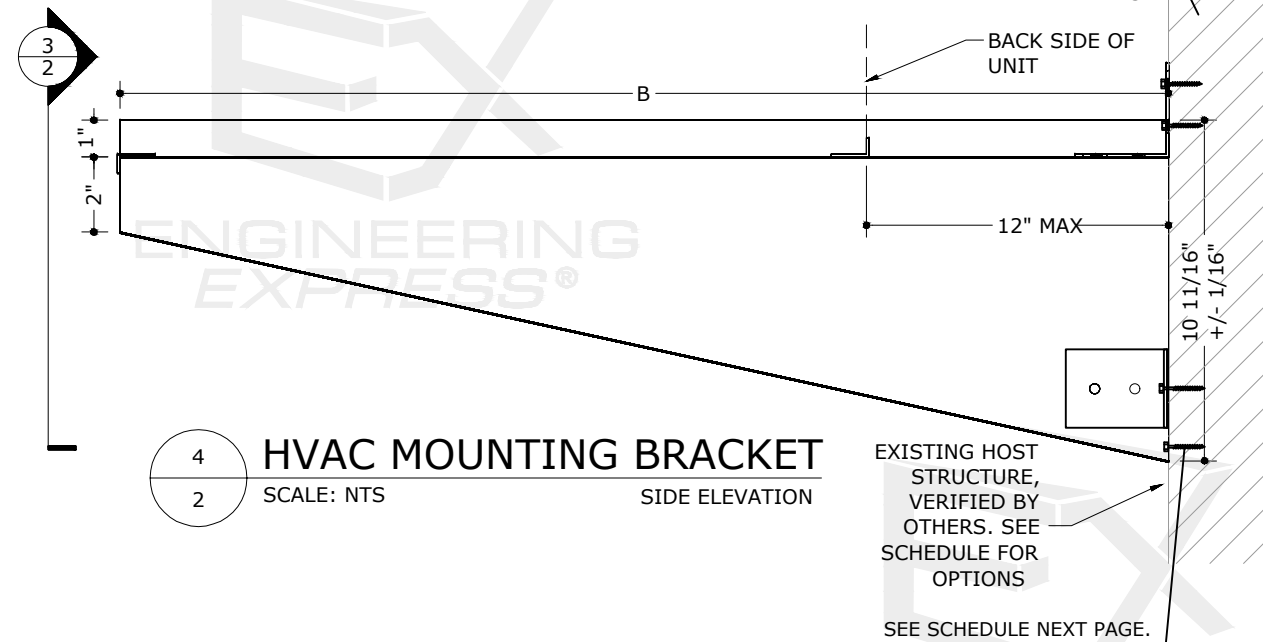

4 HVAC MOUNTING BRACKET  
2 SCALE: NTS  
SIDE ELEVATION

EMBEDMENT LISTED IS TO BE INTO SUBSTRATE LISTED & DOES NOT INCLUDE STUCCO OR FINISHES.

FL 47567.1

**ENGINEERING EXPRESS**  
POSTAL ADDRESS:  
2234 NORTH FEDERAL HWY # 7664  
BOCA RATON, FL 33431  
ENGINEERINGEXPRESS.COM

**DUCTMATE INDUSTRIES**  
210 FIFTH STREET  
CHARLEROI, PA 15022  
1-800-245-3188  
COASTAL AND INLAND HURRICANE HVAC UNIT BRACKET  
FLORIDA BUILDING CODE EIGHTH EDITION (2023)  
FLORIDA STATEWIDE APPROVAL (FSA)

REMARKS	DRWN	CHKD	DATE
INIT ISSUE	EPR	RWN	06/10/25
REV. (ORDER 21152)	EPR	RWN	12/15/25

23-67540

SCALE: NTS UNLESS NOTED

12/8/2025 2:54 PM ERICREITEI z:\shared\projects\23-123-67540 2023 fbc update -coastal & inland hurricane hvac unit bracket\work\2023 fbc\isa\drawings & cad\23-67540q - fl47567.1 - dwg.dwg

**ALLOWABLE (ASD) DESIGN PRESSURE & ANCHOR SCHEDULE:**

AIRBRACE36S MAXIMUM ALLOWABLE (ASD) WIND PRESSURE, psf						
MAX. UNIT DIMENSION [WXDXH], in	ALLOWABLE UNIT NET WEIGHT RANGE, lb	F'M=1.5 KSI MIN., ASTM C90 HOLLOW CONCRETE BLOCK	F'M=1.5KSI MIN., ASTM C90 GROUT-FILLED CONCRETE BLOCK	F'C=3KSI MIN, NORMAL-WEIGHT UNCRACKED CONCRETE	1/8" THICK IMN, ASTM A36 MIN. GALV. STEEL	G=0.55 MIN. WOOD
26X26X26	50 - 250	± 40	± 65	± 65	± 65	± 65
30x30x30		± 40	± 65	± 65	± 65	± 65
30x30x36		± 40	± 65	± 65	± 65	± 65
30x30x42		± 40	± 65	± 65	± 65	± 65
28x26x30		± 40	± 65	± 65	± 65	± 65
28x26x36		± 40	± 65	± 65	± 65	± 65
28x26x42		± 40	± 65	± 65	± 65	± 65
AIRBRACE45S MAXIMUM ALLOWABLE (ASD) WIND PRESSURE, psf						
MAX. UNIT DIMENSION [WXDXH], in	ALLOWABLE UNIT NET WEIGHT RANGE, lb	F'M=1.5 KSI MIN., ASTM C90 HOLLOW CONCRETE BLOCK	F'M=1.5KSI MIN., ASTM C90 GROUT-FILLED CONCRETE BLOCK	F'C=3KSI MIN, NORMAL-WEIGHT UNCRACKED CONCRETE	1/8" THICK IMN, ASTM A36 MIN. GALV. STEEL	G=0.55 MIN. WOOD
36x36x30	50 - 300 (FOR HOLLOW CMU)	± 40	± 65	± 65	± 65	± 65
36x36x36		± 40	± 65	± 65	± 65	± 65
36x36x42		± 35	± 65	± 65	± 65	± 65
36x36x54	50 - 375 (FOR OTHER HOST MATERIAL OPTIONS)	± 35	± 65	± 65	± 65	± 65
37x34x30		± 40	± 65	± 65	± 65	± 65
37x34x36		± 40	± 65	± 65	± 65	± 65
37x34x42		± 35	± 65	± 65	± 65	± 65
37x34x54		± 35	± 65	± 65	± 65	± 65
AIRBRACE55S MAXIMUM ALLOWABLE (ASD) WIND PRESSURE, psf						
MAX. UNIT DIMENSION [WXDXH], in	ALLOWABLE UNIT NET WEIGHT RANGE, lb	F'M=1.5 KSI MIN., ASTM C90 HOLLOW CONCRETE BLOCK	F'M=1.5KSI MIN., ASTM C90 GROUT-FILLED CONCRETE BLOCK	F'C=3KSI MIN, NORMAL-WEIGHT UNCRACKED CONCRETE	1/8" THICK IMN, ASTM A36 MIN. GALV. STEEL	G=0.55 MIN. WOOD
48x48x30	50 - 300 (FOR HOLLOW CMU)	± 35	± 65	± 65	± 65	± 65
48x48x36		± 35	± 65	± 65	± 65	± 65
48x48x42		± 35	± 65	± 65	± 65	± 65
48x48x48		± 35	± 65	± 65	± 65	± 65
48x48x54		± 35	± 65	± 65	± 65	± 65
46x43x30	50 - 425 (FOR OTHER HOST MATERIAL OPTIONS)	± 35	± 65	± 65	± 65	± 65
46x43x36		± 35	± 65	± 65	± 65	± 65
46x43x42		± 35	± 65	± 65	± 65	± 65
46x43x48		± 35	± 65	± 65	± 65	± 65
46x43x54		± 35	± 65	± 65	± 65	± 65

**ANCHORING DIRECTIVE:**

- HOLLOW BLOCK: PROVIDE (5) ANCHORS PER WALL BRACKET: (2) AT THE TOP SUPPORT BRACKET, (2) AT THE BOTTOM SUPPORT BRACKETS, AND (1) AT THE BOTTOM INTEGRATED TAB. HOLLOW BLOCK ANCHORS SHALL BE: 5/16" Ø DEWALT ULTRACON SCREW ANCHORS WITH 1-1/4" EMBED., 1-7/8" MIN. SPACING, AND 3-1/8" MIN. EDGE DIST. TO ANY EDGE/END OF THE HOLLOW BLOCK HOST STRUCTURE.
- GROUT-FILLED CONCRETE BLOCK: PROVIDE (2) ANCHORS PER WALL BRACKET: (1) AT THE TOP SUPPORT BRACKET, AND (1) AT THE BOTTOM INTEGRATED TAB. ANCHORS SHALL BE: 1/2" Ø DEWALT SCREW-BOLT+ WITH 4" EMBED AND 12" MIN. EDGE DIST., TYP.
- CONCRETE: PROVIDE (2) ANCHORS PER WALL BRACKET: (1) AT THE TOP SUPPORT BRACKET, AND (1) AT THE BOTTOM INTEGRATED TAB. ANCHORS SHALL BE: 1/2" Ø DEWALT SCREW-BOLT+ WITH 3.5" EMBED AND 8" MIN. EDGE DIST., TYP.
- STEEL: PROVIDE (3) ANCHORS PER WALL BRACKET: (2) AT THE TOP SUPPORT BRACKET, AND (1) AT THE BOTTOM INTEGRATED TAB. ANCHORS SHALL BE 1/2" Ø SAE GR 5 UNC BOLTS.
- WOOD: PROVIDE (3) ANCHORS PER WALL BRACKET: (2) AT THE TOP SUPPORT BRACKET, AND (1) AT THE BOTTOM INTEGRATED TAB. ANCHORS SHALL BE 1/2" Ø LAG SCREWS WITH 2.5" MIN. THREAD PENETRATION & 3/4" MIN. EDGE DIST., TYP.

EMBED. SHALL BE THE FULL EMBEDMENT INTO THE HOLLOW BLOCK; EMBEDMENT DEPTH DOES NOT INCLUDE THICKNESS OF ANY WOOD BUCKS, STUCCO, OR FINISHES. HOST STRUCTURE INTEGRITY SHALL BE BY OTHERS. SEE SCHEDULE FOR HOST STRUCTURE MINIMUM SPECIFICATIONS, TYP.

THIS MOUNTING BRACKET SYSTEM IS CERTIFIED ONLY FOR ATTACHMENTS TO THE SIDE OF BUILDINGS, NOT FOR ROOFTOP CONDITIONS OR INSTALLATIONS. THIS PRODUCT IS NOT APPROVED FOR MISSILE IMPACT UNDER ANY CIRCUMSTANCE.

FL 47567.1

**ENGINEERING EXPRESS**  
 POSTAL ADDRESS:  
 2234 NORTH FEDERAL HWY # 7664  
 BOCA RATON, FL 33431  
 ENGINEERINGEXPRESS.COM

**DUCTMATE INDUSTRIES**  
 210 FIFTH STREET  
 CHARLOTTE, PA 15022  
 1-800-245-3188  
 COASTAL AND INLAND HURRICANE HVAC UNIT BRACKET  
 FLORIDA BUILDING CODE EIGHTH EDITION (2023)  
 FLORIDA STATEWIDE APPROVAL (FSA)

REMARKS	DRWN	CHKD	DATE
INIT ISSUE	EPR	RWN	06/10/25
REV. (ORDER 21152)	EPR	RWN	12/15/25

23-67540

SCALE: NTS UNLESS NOTED

ERICREITEI z:\shared\projects\23-123-67540 2023 fbc update - coastal & inland hurricane hvac unit bracket\work\2023 fbc\isa\drawings & ca\23-67540q - fl47567.1 - dwg.dwg  
 12/8/2025 2:54 PM