

SERIES PW5520V IMPACT RESISTANT, VINYL PICTURE WINDOW

FLORIDA PRODUCT APPROVAL #5012

DESIGN PRESSURE RATING
SEE TABLE 1

IMPACT RATING
RATED FOR LARGE & SMALL MISSILE IMPACT RESISTANCE MISSILE LEVEL D, WINDZONE 4

1) THIS PRODUCT HAS BEEN DESIGNED & TESTED TO COMPLY WITH THE REQUIREMENTS OF THE CURRENT FLORIDA BUILDING CODE.

2) SHUTTERS ARE NOT REQUIRED WHEN USED IN WIND-BORNE DEBRIS REGIONS.

3) MASONRY ANCHORS MAY BE USED INTO WOOD AS PER TABLES 2 & 3. ALL WOOD BUCKS LESS THAN 1-1/2" THICK ARE TO BE CONSIDERED 1X INSTALLATIONS. 1X WOOD BUCKS ARE OPTIONAL IF UNIT IS INSTALLED DIRECTLY TO SUBSTRATE. WOOD BUCKS DEPICTED AS 2X ARE 1-1/2" THICK OR GREATER. 1X AND 2X BUCKS (WHEN USED) SHALL BE DESIGNED TO PROPERLY TRANSFER LOADS TO THE STRUCTURE. WOOD BUCK DESIGN AND INSTALLATION IS THE RESPONSIBILITY OF THE ENGINEER OR ARCHITECT OF RECORD.

4) ANCHOR EMBEDMENT TO BASE MATERIAL SHALL BE BEYOND WALL DRESSING OR STUCCO. USE ANCHORS OF SUFFICIENT LENGTH. ANCHORS AND FRAME CORNERS SHOULD BE SEALED. OVERALL SEALING/FLASHING STRATEGY FOR WATER RESISTANCE OF INSTALLATION SHALL BE DONE BY OTHERS AND IS BEYOND THE SCOPE OF THESE INSTRUCTIONS.

5) SHIMS ARE REQUIRED AT EACH ANCHOR LOCATION WHERE THE PRODUCT IS NOT FLUSH TO THE SUBSTRATE. USE SHIMS CAPABLE OF TRANSFERRING APPLIED LOADS. WOOD BUCKS, BY OTHERS, MUST BE SUFFICIENTLY ANCHORED TO RESIST LOADS IMPOSED ON THEM BY THE WINDOW.

6) THE ANCHORAGE METHODS SHOWN HAVE BEEN DESIGNED TO RESIST THE WIND LOADS CORRESPONDING TO THE REQUIRED DESIGN PRESSURE. THE 33-1/3% STRESS INCREASE HAS NOT BEEN USED IN THE DESIGN OF THIS PRODUCT. THE 1.6 LOAD DURATION FACTOR WAS USED FOR THE EVALUATION OF ANCHORS INTO WOOD. ANCHORS THAT COME INTO CONTACT WITH OTHER DISSIMILAR MATERIALS SHALL MEET THE REQUIREMENTS OF THE FLORIDA BUILDING CODE FOR CORROSION RESISTANCE.

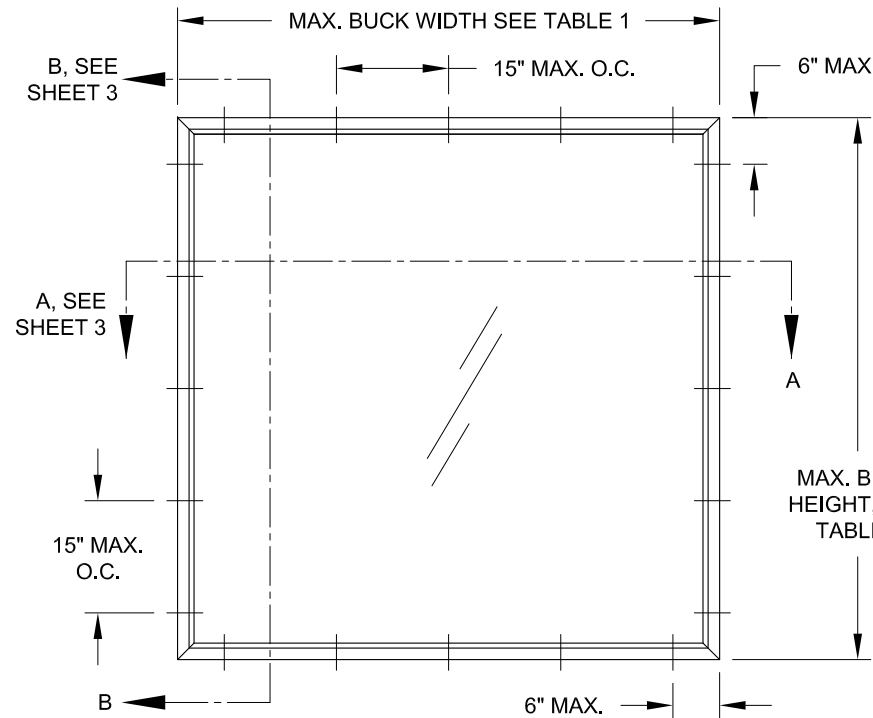

TYP. EQUAL-LEG/BOX & FLANGE FRAME (SHAPES SIMILAR)

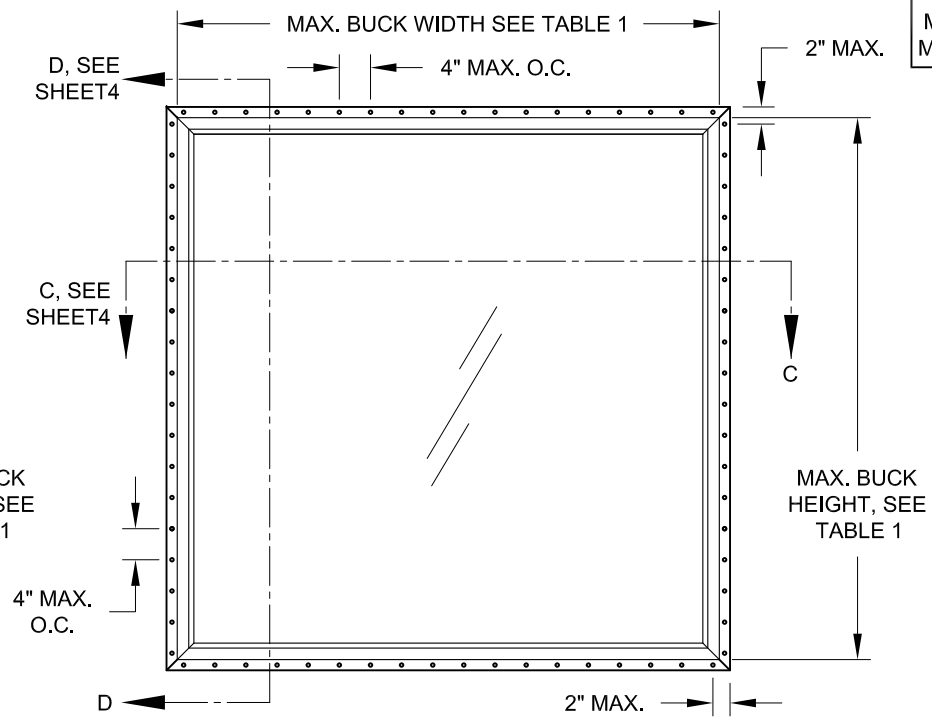

TYP. INTEGRAL FIN & J-CHANNEL FRAME (SHAPES SIMILAR)

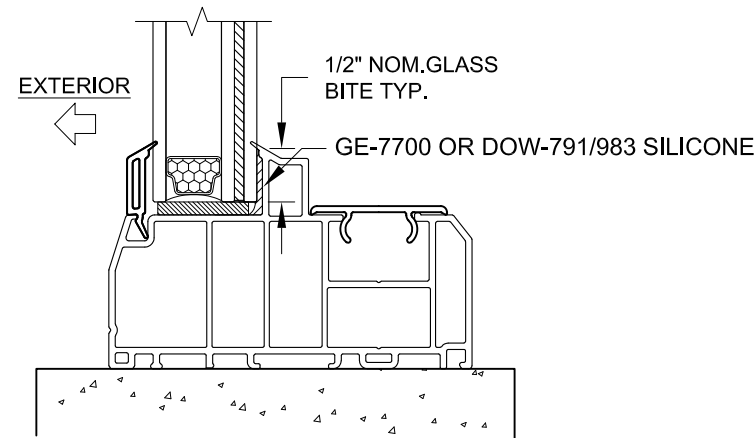

TYP. GLAZING DETAIL

SHAPES MAY BE USED BY INSCRIBING THE SHAPE IN A BLOCK AND OBTAINING DESIGN PRESSURES FOR THAT BLOCK SIZE FROM THE TABLE ON THIS SHEET.

TABLE 1:

Window Buck Size		Design Pressure		Product Rating
Width	Height	(+) psf	(-) psf	
84	54	65.0*	65.0*	CW-PG70
84	54	70.0	70.0	CW-PG70
84	72	70.0	70.0	CW-PG70
96	63	70.0	70.0	CW-PG70
75	48	50.0	50.0	CW-PG50
36	72	50.0	50.0	CW-PG50

* IMPACT/CYCLE DESIGN PRESSURE IS LIMITED FOR UNITS USING AN ANNEALED GLASS CAP.

Rev. #	C
Date	08/01/22
Method	UPDATED CERT. METHOD

PREPARED BY A. LYNN MILLER
1070 TECHNOLOGY DRIVE
N. VENICE, FL 34275
(941) 480-1600

REGISTRATION #29296
COPYRIGHT © 2022 PGT, INC., LIMITED LICENSE
TO MAKE COPIES FOR PERMITTING.

1070 TECHNOLOGY DRIVE
N. VENICE, FL 34275
(941) 480-1600

VINYL PICTURE WINDOW (LM)

ELEVATION & GENERAL NOTES

JENS ROSOWSKI

06/12/11

1 OF 4

PW5520V

PW5520FPA-LM

ANTHONY LYNN MILLER
LICENSE
No. 58705
08/08/22
STATE OF FLORIDA
PROFESSIONAL ENGINEER
A. LYNN MILLER, P.E.
P.E.# 58705

TABLE 2: ANCHORS INSTALLED THROUGH FRAME

Anchor	Substrate	Min. Edge Distance	Min. Embedment
#10 SMS (steel, 18-8 S.S. or 410 S.S.) Max. DP of 50.0 psf	P.T. Southern Pine (SG=0.55)	7/16"	1-3/8"
	Steel, A36	3/8"	0.050"
	Steel Stud, A653 Gr. 33	3/8"	0.0346" (20 Ga.)
#12 SMS (steel, 18-8 S.S. or 410 S.S.)	Aluminum, 6063-T5	3/8"	0.0713" (14 Ga.)
	P.T. Southern Pine (SG=0.55)	9/16"	1-3/8"
	Steel, A36	3/8"	0.050"
3/16" Ultracon Max. DP of 50.0 psf	Steel Stud, A653 Gr. 33	3/8"	0.0346" (20 Ga.)
	Aluminum, 6063-T5	3/8"	0.0713" (14 Ga.)
	P.T. Southern Pine (SG=0.55)	7/16"	1-3/8"
3/16" Ultracon+ Max. DP of 50.0 psf	Concrete (min. 2.85 ksi)	1"	1-3/8"
	UngROUTED CMU, (ASTM C-90)	2-1/2"	1-1/4"
	P.T. Southern Pine (SG=0.55)	7/16"	1-3/8"
1/4" Ultracon	Concrete (min. 3 ksi)	1"	1-3/8"
	UngROUTED CMU, (ASTM C-90)	1"	1-1/4"
	P.T. Southern Pine (SG=0.55)	1"	1-3/8"
1/4" Ultracon+	Concrete (min. 2.85 ksi)	1"	1-3/4"
	UngROUTED CMU, (ASTM C-90)	2-1/2"	1-1/4"
	P.T. Southern Pine (SG=0.55)	1"	1-3/8"
1/4" Crete-Flex (410 S.S.)	Concrete (min. 3 ksi)	1-3/16"	1-3/4"
	UngROUTED CMU, (ASTM C-90)	1"	1-1/4"
	P.T. Southern Pine (SG=0.55)	1"	1-3/8"
1/4" Aggre-Gator (18-8 S.S.)	Concrete (min. 3.35 ksi)	1"	1-3/4"
	UngROUTED CMU, (ASTM C-90)	2-1/2"	1-1/4"
	P.T. Southern Pine (SG=0.55)	1"	1-3/8"
1/4" Aggre-Gator (18-8 S.S.)	Concrete (min. 3.275 ksi)	1-1/2"	1-3/8"
	UngROUTED CMU, (ASTM C-90)	2"	1-1/4"
	P.T. Southern Pine (SG=0.55)	1"	1-3/8"

- "UNGRouted CMU" VALUES MAY BE USED FOR GROUTED CMU APPLICATIONS.
- PANHEAD, FLATHEAD OR HEXHEAD ARE ACCEPTABLE.
- ANCHOR LENGTH TO BE SO THAT A MIN. OF 3 THREADS EXTEND BEYOND THE METAL SUBSTRATE.

TABLE 3: ANCHORS INSTALLED THROUGH INTEGRAL FIN

Anchor	Substrate	Min. Edge Distance	Min. Embedment
2-1/2" x .131" Common Nail Max. DP of 50.0	P.T. Southern Pine (SG=.55)	9/16"	2-7/16"
	P.T. Southern Pine (SG=.55)	9/16"	2-7/16"
2-1/2" x .145" Ring-shank Nail	P.T. Southern Pine (SG=.55)	9/16"	2-7/16"
	P.T. Southern Pine (SG=.55)	9/16"	2-7/16"
#10 SMS (steel, 18-8 S.S. or 410 S.S.)	P.T. Southern Pine (SG=.55)	3/4"	1-3/8"
	Aluminum, 6063-T5	3/8"	0.050"
	Steel Stud, Gr. 33	3/8"	0.0346" (20 Ga.)
	Steel, A36	3/8"	0.050"

1) PANHEAD, FLATHEAD OR HEXHEAD ARE ACCEPTABLE.

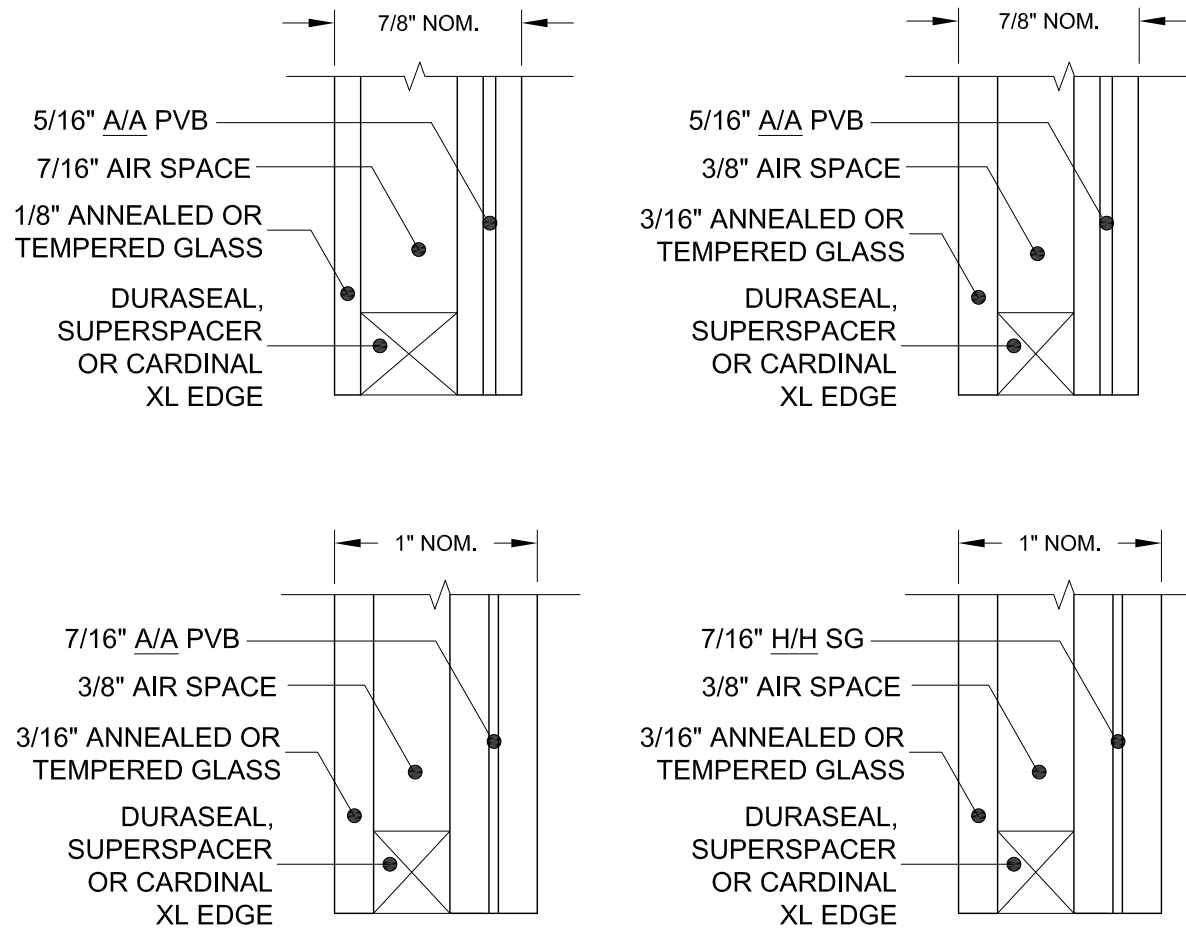

GLAZING TYPES

VISIBLE LIGHT FORMULAS

WIDTH: BUCK WIDTH - 4-5/16"
HEIGHT: BUCK HEIGHT - 4-5/16"

VISIBLE LIGHT WIDTH OR HEIGHT (ALSO REFERRED TO AS DAYLIGHT OPENING) IS MEASURED FROM BEADING TO BEADING.

PVB = KURARAY TROSIFOL PVB INTERLAYER BY KURARAY AMERICA, INC.
A = ANNEALED
H = HEAT STRENGTHENED

Rev. # 08/01/22
Date
Updated Cert. Method
C

PREPARED BY A. LYNN MILLER 1070 TECHNOLOGY DRIVE N. VENICE, FL 34275 (941) 480-1600	REGISTRATION #29296 COPYRIGHT © 2022 PGT, INC., LIMITED LICENSE TO MAKE COPIES FOR PERMITTING.	06/12/11 Date	JENS ROSOWSKI By	PW5520FPA-LM No. DWG
	1070 TECHNOLOGY DRIVE N. VENICE, FL 34275 (941) 480-1600	VINYL PICTURE WINDOW (LM) ANCHORS AND GLAZING DETAILS	PW5520V Sheet	2 OF 4 Sheet

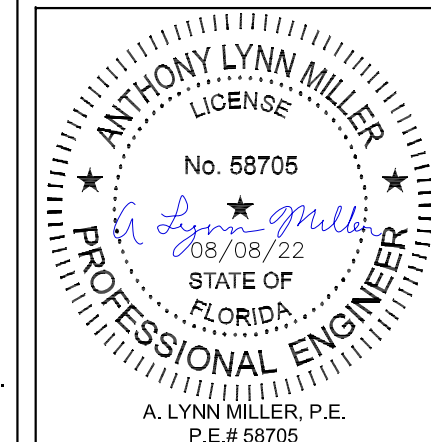

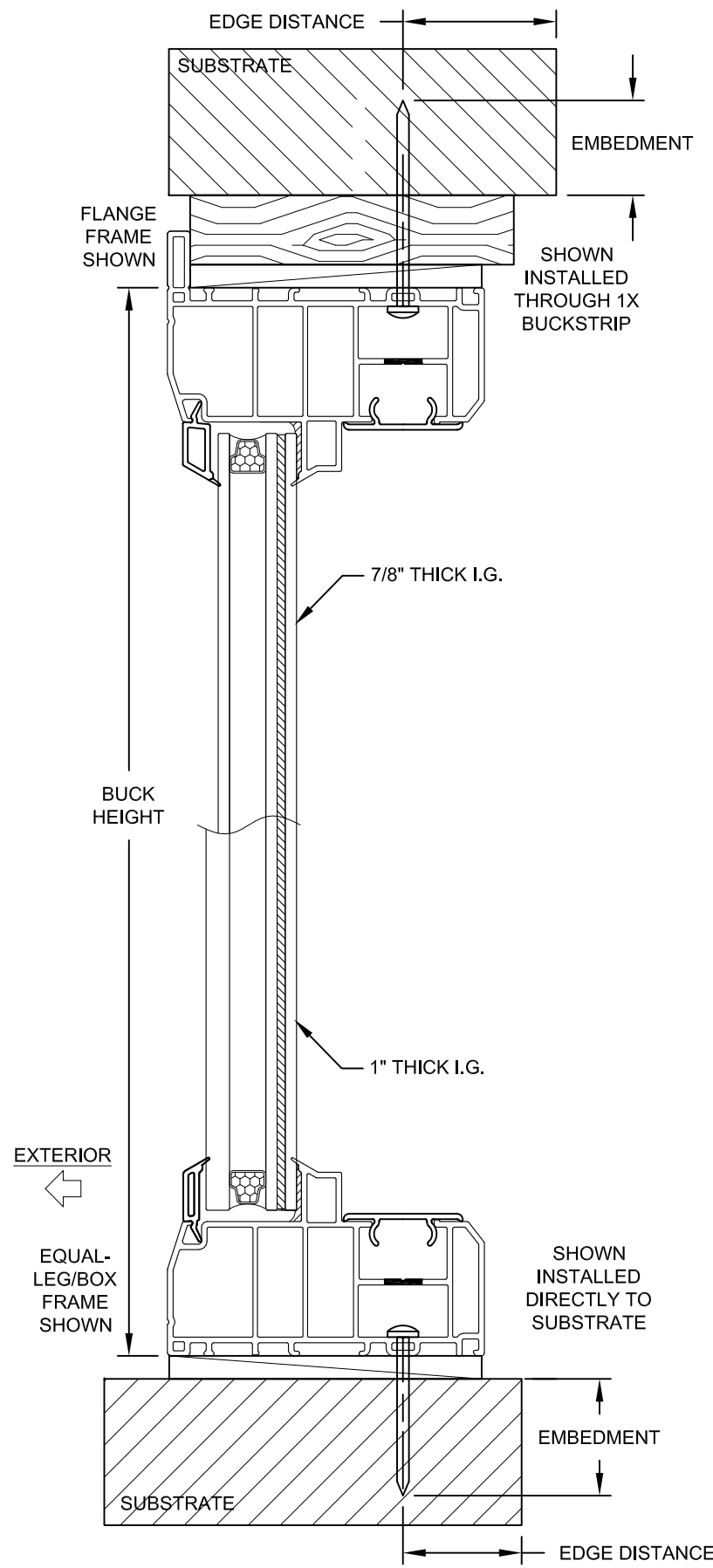

VERTICAL SECTION B-B

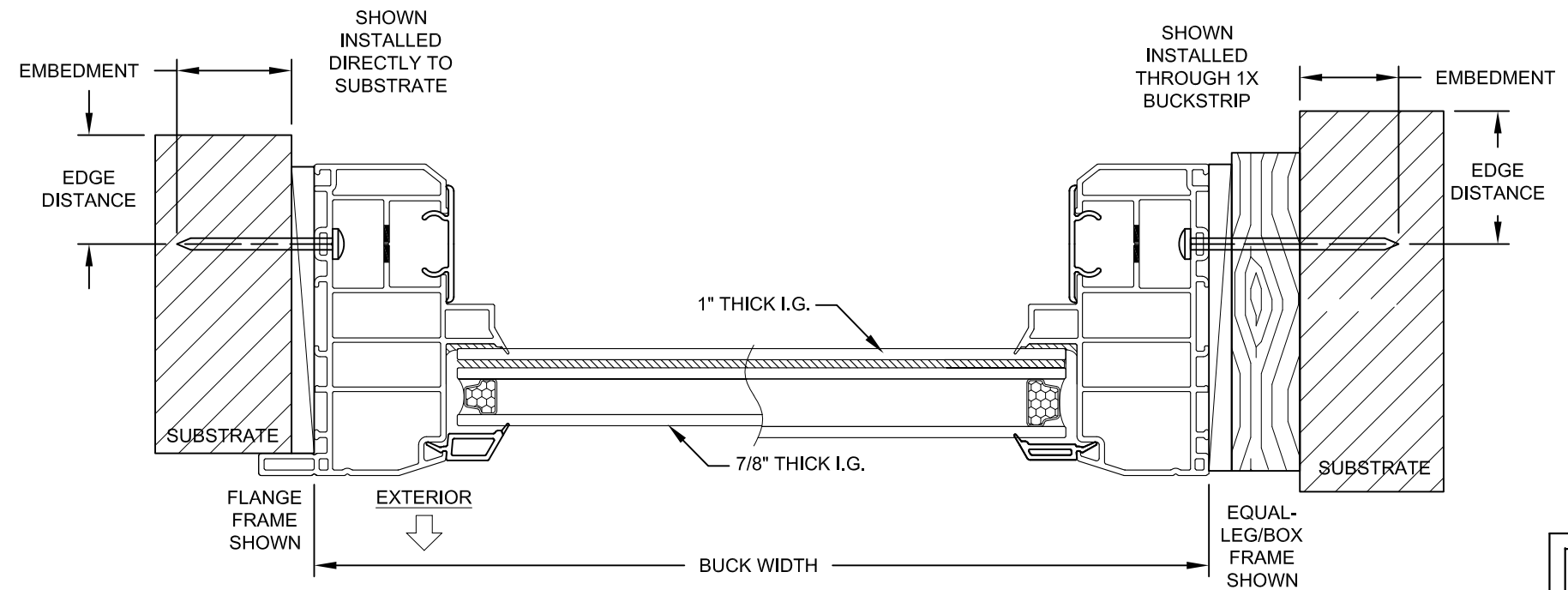

HORIZONTAL SECTION A-A

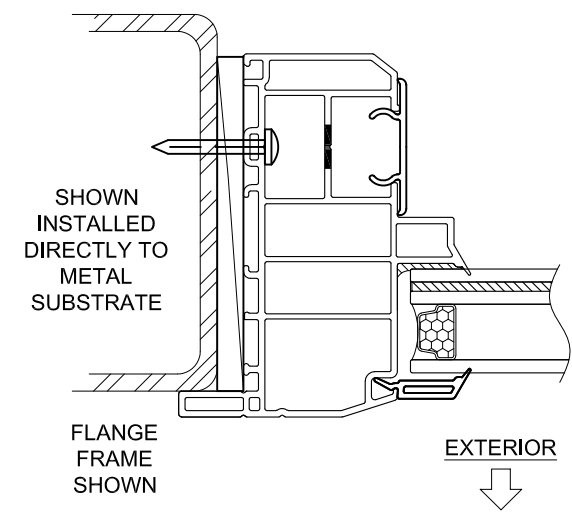

INSTALLATION NOTES:

- 1) SEE SHEET 1 FOR SPACING REQUIREMENTS.
- 2) SEE TABLE(S) ON SHEET 2 FOR ANCHORAGE AND SUBSTRATE REQUIREMENTS.
- 3) MAX. SHIM THICKNESS TO BE 1/4".
- 4) GLASS SHOWN IS FOR ILLUSTRATIVE PURPOSES ONLY AND MAY DIFFER TO MEET DESIGN REQUIREMENTS.
- 5) FIN AND/OR FLANGE MAY BE REMOVED TO CREATE OTHER FRAME TYPES.

PREPARED BY A. LYNN MILLER 1070 TECHNOLOGY DRIVE N. VENICE, FL 34275 (941) 480-1600	REGISTRATION #29296 COPYRIGHT © 2022 PGT, INC., LIMITED LICENSE TO MAKE COPIES FOR PERMITTING.	Date 06/12/11	Drawn By JENS ROSOWSKI	DWG No. PW5520FPA-LM
	1070 TECHNOLOGY DRIVE N. VENICE, FL 34275 (941) 480-1600	VINYL PICTURE WINDOW (LM) FLANGE/EQUAL-LEG INSTALLATION	Sheet PW5520V	3 OF 4

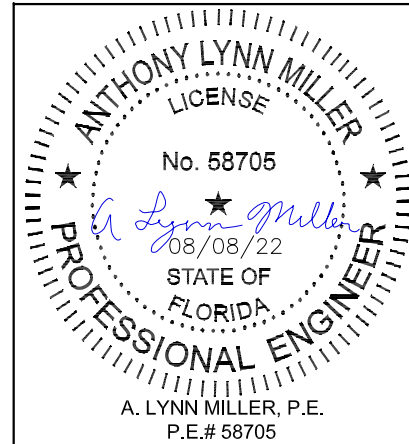

Rev. #	08/01/22
Date	
Rev.	UPDATED CERT. METHOD
	C

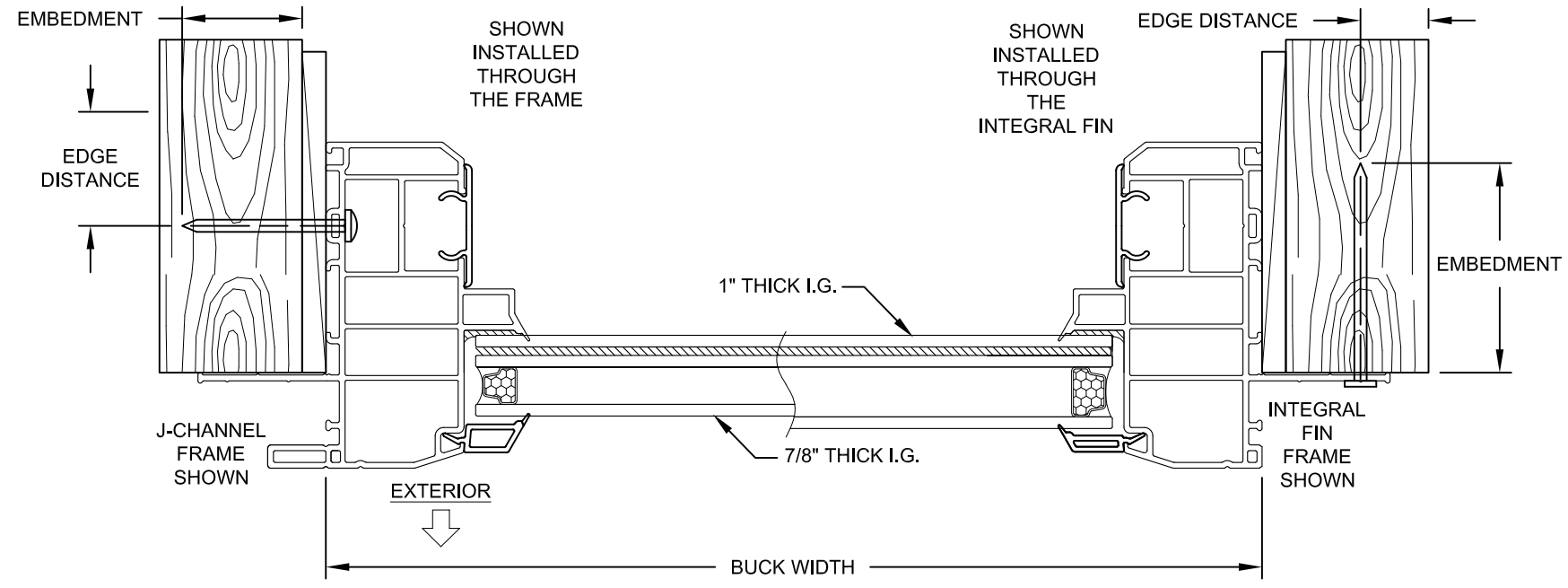
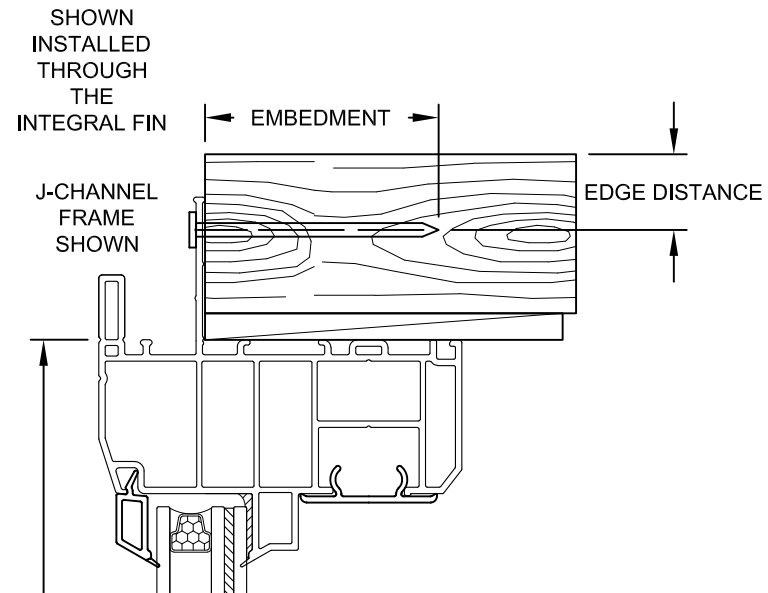

HORIZONTAL SECTION C-C

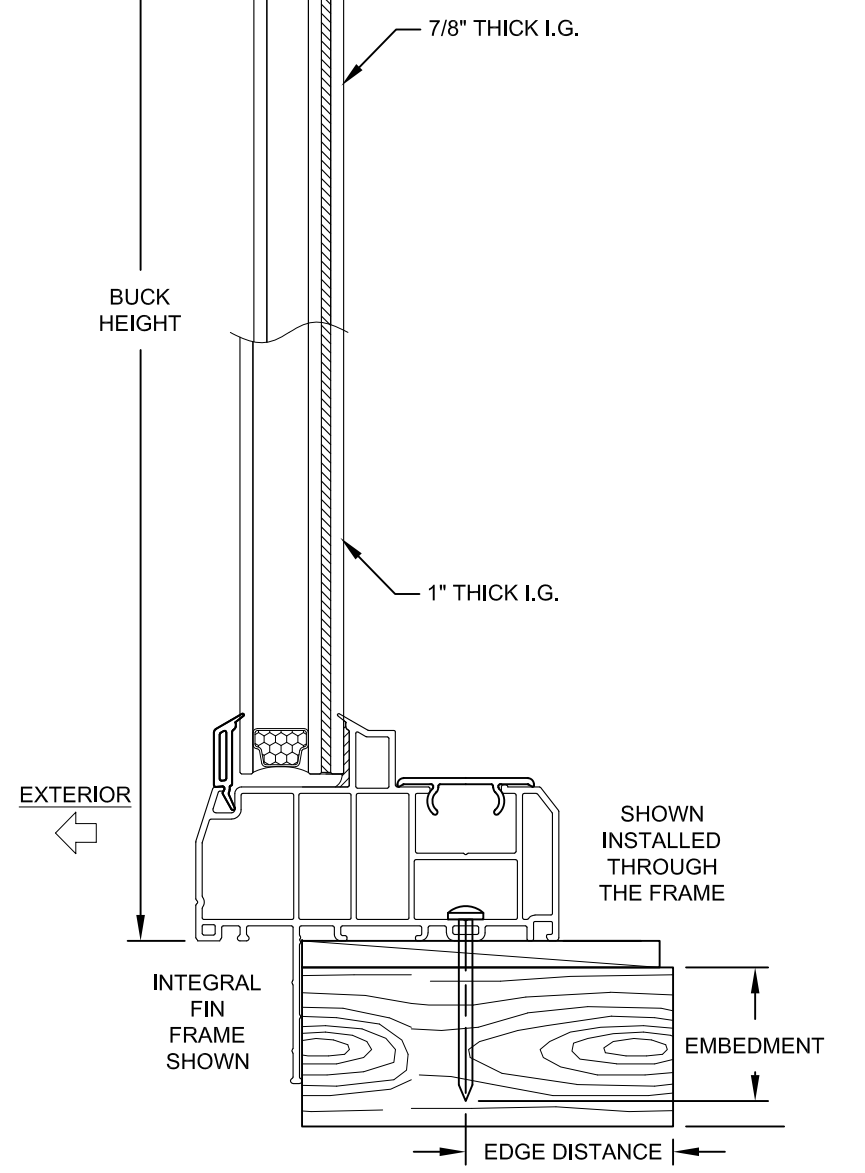

VERTICAL SECTION D-D

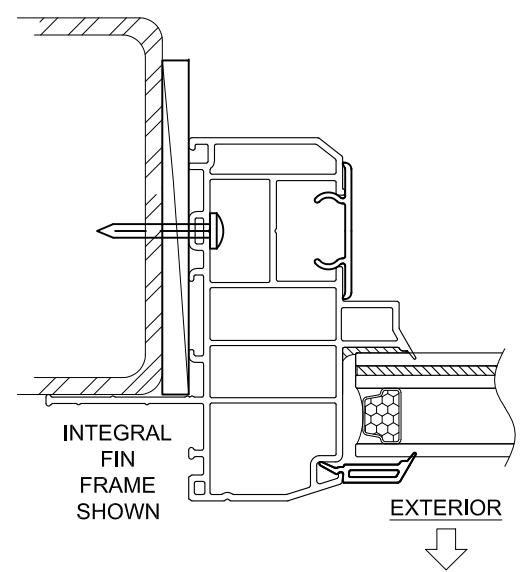

INSTALLATION THROUGH THE FRAME, INTO METAL

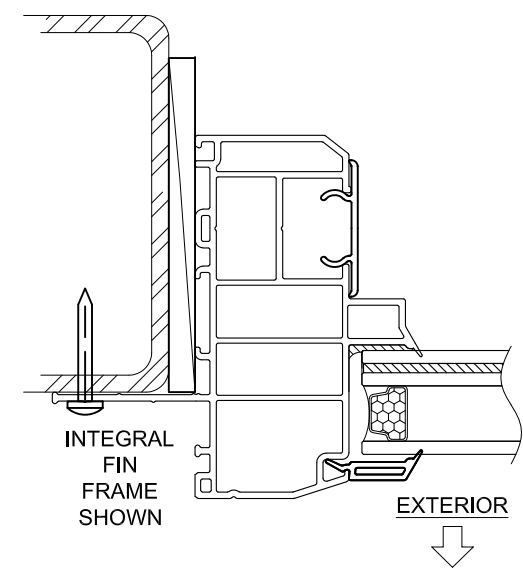

INSTALLATION THROUGH THE INTEGRAL FIN, INTO METAL

INSTALLATION NOTES:

- 1) SEE SHEET 1 FOR SPACING REQUIREMENTS.
- 2) SEE TABLE(S) ON SHEET 2 FOR ANCHORAGE AND SUBSTRATE REQUIREMENTS.
- 3) MAX. SHIM THICKNESS TO BE 1/4".
- 4) GLASS SHOWN IS FOR ILLUSTRATIVE PURPOSES ONLY AND MAY DIFFER TO MEET DESIGN REQUIREMENTS.
- 5) FIN AND/OR FLANGE MAY BE REMOVED TO CREATE OTHER FRAME TYPES.

PREPARED BY A. LYNN MILLER 1070 TECHNOLOGY DRIVE N. VENICE, FL 34275 (941) 480-1600	REGISTRATION #29296 COPYRIGHT © 2022 PGT, INC., LIMITED LICENSE TO MAKE COPIES FOR PERMITTING.	Date 06/12/11	Drawn By JENS ROSOWSKI	DWG No. PW5520FPA-LM
	1070 TECHNOLOGY DRIVE N. VENICE, FL 34275 (941) 480-1600	VINYL PICTURE WINDOW (LM)	Sheet 4 OF 4	Series PW5520V

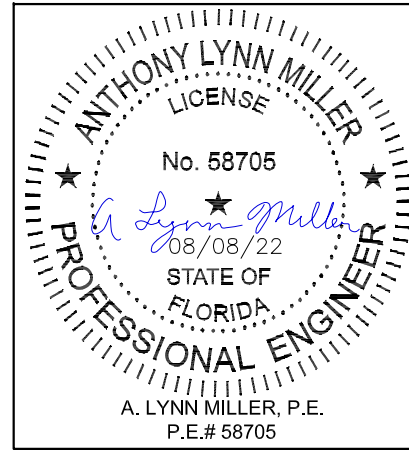

A. LYNN MILLER, P.E.
P.E.# 58705