



NEMO|etc.

Certificate of Authorization #32455
353 Christian Street, Unit #13
Oxford, CT 06478
(203) 262-9245

ENGINEER

EVALUATE

TEST

CONSULT

CERTIFY

EVALUATION REPORT

CertainTeed Corporation

20 Moores Road
Malvern, PA 19355
(610) 651-5847

Evaluation Report 3532.09.05-R16

FL5444-R15

Date of Issuance: 09/22/2005

Revision 16: 08/14/2019

SCOPE:

This Evaluation Report is issued under **Rule 61G20-3** and the applicable rules and regulations governing the use of construction materials in the State of Florida. The documentation submitted has been reviewed by Robert Nieminen, P.E. for use of the product under the Florida Building Code and Florida Building Code, Residential Volume. The products described herein have been evaluated for compliance with the **6th Edition (2017) Florida Building Code** sections noted herein.

DESCRIPTION: CertainTeed Asphalt Roof Shingles.

LABELING: Labeling shall be in accordance with the requirements of the Accredited Quality Assurance Agency noted herein and **FBC 1507.2.7.1 / R905.2.6.1**

CONTINUED COMPLIANCE: This Evaluation Report is valid until the named product(s) changes, the referenced Quality Assurance documentation changes, or provisions of the Code that relate to the product change. Acceptance of this Evaluation Report by the named client constitutes agreement to notify Robert Nieminen, P.E. of any changes to the product(s), the Quality Assurance or the production facility location(s). NEMO|etc. requires a complete review of this Evaluation Report relative to updated Code requirements with each Code Cycle.

ADVERTISEMENT: The Evaluation Report number preceded by the words "NEMO|etc. Evaluated" may be displayed in advertising literature. If any portion of the Evaluation Report is displayed, then it shall be done in its entirety.

INSPECTION: Upon request, a copy of this entire Evaluation Report shall be provided to the user by the manufacturer or its distributors and shall be available for inspection at the job site at the request of the Building Official.

This Evaluation Report consists of pages 1 through 15.

Prepared by:

Robert J.M. Nieminen, P.E.

Florida Registration No. 59166, Florida DCA ANE1983

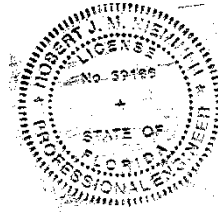

The facsimile seal appearing was authorized by Robert Nieminen, P.E. on 08/14/2019. This does not serve as an electronically signed document.

CERTIFICATION OF INDEPENDENCE:

1. NEMO|etc. does not have, nor does it intend to acquire, or will it acquire, a financial interest in any company manufacturing or distributing products it evaluates.
2. NEMO|etc. is not owned, operated or controlled by any company manufacturing or distributing products it evaluates.
3. Robert Nieminen, P.E. does not have nor will acquire, a financial interest in any company manufacturing or distributing products for which the evaluation reports are being issued.
4. Robert Nieminen, P.E. does not have, nor will acquire, a financial interest in any other entity involved in the approval process of the product.
5. This is a building code evaluation. Neither NEMO|etc. nor Robert Nieminen, P.E. are, in any way, the Designer of Record for any project on which this Evaluation Report, or previous versions thereof, is/was used for permitting or design guidance unless retained specifically for that purpose.

ROOFING SYSTEMS EVALUATION:
1. SCOPE:

Product Category: Roofing
Sub-Category: Asphalt Shingles

Compliance Statement: CertainTeed Asphalt Roof Shingles, as produced by CertainTeed Corporation, have demonstrated compliance with the following sections of the 6th Edition (2017) Florida Building Code and 6th Edition (2017) Florida Building Code, Residential Volume through testing in accordance with the following Standards. Compliance is subject to the Installation Requirements and Limitations / Conditions of Use set forth herein.

2. STANDARDS:

<u>Section</u>	<u>Property</u>	<u>Standard</u>	<u>Year</u>
1507.2.5, R905.2.4	Physical Properties	ASTM D3462	2010
1507.2.7.1, R905.2.6.1	Wind Resistance	ASTM D3161	2016
1507.2.7.1, R905.2.6.1	Wind Resistance	ASTM D7158	2011

3. REFERENCES:

<u>Entity</u>	<u>Examination</u>	<u>Reference</u>	<u>Date</u>
PRI (TST 5878)	ASTM D3161	256T0015	08/12/2019
UL (TST 1740)	ASTM D3161	94NK9632	05/15/1998
UL (TST 1740)	ASTM D3161	99NK26506	11/23/1999
UL (TST 1740)	ASTM D3161	03CA12702	05/27/2003
UL (TST 1740)	ASTM D3161	03CA12702	06/16/2003
UL (TST 1740)	ASTM D3161	03NK29847	10/03/2003
UL (TST 1740)	ASTM D3161	04CA11329	05/24/2004
UL (TST 1740)	ASTM D3161	04CA32986	12/03/2004
UL (TST 1740)	ASTM D3161	05NK07049	04/15/2005
UL (TST 1740)	ASTM D3161	05NK16778	05/12/2005
UL (TST 1740)	ASTM D3161	05CA16778	05/12/2005
UL (TST 1740)	ASTM D3161	05NK14836	05/22/2005
UL (TST 1740)	ASTM D3161	05NK22800	06/22/2005
UL (TST 1740)	ASTM D3462	R684	09/21/2005
UL (TST 1740)	ASTM D7158	05NK08037	06/28/2006
UL (TST 1740)	ASTM D3161 & D3462	09CA28873	07/23/2009
UL (TST 1740)	ASTM D3462	10CA41303	10/07/2010
UL (TST 1740)	ASTM D3161	10CA41303	10/08/2010
UL (TST 1740)	ASTM D7158	10CA41303	10/27/2010
UL (TST 1740)	ASTM D3161 & D3462	10CA44960	11/11/2010
UL LLC (TST 9628)	ASTM D3161, D3462 & D7158	13CA32897	11/21/2013
UL LLC (TST 9628)	ASTM D3161, D3462	TFWZ.R684	04/22/2014
UL LLC (TST 9628)	ASTM D7158	TGAH.R684	04/22/2014
UL LLC (TST 9628)	ASTM D3161 & D3462	4786334434	09/16/2014
UL LLC (TST 9628)	ASTM D3161 & D3462	4786570826	02/12/2015
UL LLC (TST 9628)	ASTM D3161	4786821352	02/21/2015
UL LLC (TST 9628)	ASTM D3161, D3462 & D7158	4786570717	12/16/2015
UL LLC (TST 9628)	ASTM D3161 & D3462	4787195678	02/09/2016
UL LLC (TST 9628)	ASTM D3161, D3462 & D7158	4787592174	10/21/2016
UL LLC (TST 9628)	ASTM D3161, D3462 & D7158	4787380356	10/26/2016
UL LLC (TST 9628)	ASTM D3462	4787380357	10/13/2016
UL LLC (TST 9628)	ASTM D7158	4787380357	11/08/2016
UL LLC (TST 9628)	ASTM D3161	4787380357	11/09/2016
UL LLC (TST 9628)	ASTM D3161, D3462 & D7158	4787586427	01/25/2017
UL LLC (TST 9628)	ASTM D3161 & D3462	4788042412	11/15/2017
UL LLC (TST 9628)	ASTM D3161, D3462 & D7158	4788362767	03/03/2018
UL LLC (QUA 9625)	Quality Control	Service Confirmation	Exp. 03/09/2020

4. PRODUCT DESCRIPTION:

4.1 Asphalt Shingles:

- 4.1.1 **CT20™, XT™ 25, XT™ 30 and XT™ 30 IR** are fiberglass reinforced, 3-tab asphalt roof shingles.
- 4.1.2 **Arcadia™, Belmont®, Belmont® IR, Carriage House Shingle®, Grand Manor Shangle®, Landmark™, Landmark™ IR, Landmark™ Pro, Landmark™ Pro Solaris, Landmark™ Premium, Landmark™ TL, Landmark™ Solaris, Landmark™ Solaris IR and Landmark™ Solaris Gold/Platinum** are fiberglass reinforced, laminated asphalt roof shingles.
- 4.1.3 **NorthGate™** is a fiberglass reinforced, laminated, SBS modified bitumen roof shingle.
- 4.1.4 **Presidential Shake™, Presidential Shake™ IR, Presidential Shake TL™ and Presidential Solaris™** are fiberglass reinforced, architectural asphalt roof shingles.
- 4.1.5 **Hatteras™, Highland Slate™ and Highland Slate™ IR** are fiberglass reinforced, 4-tab asphalt roof shingles.
- 4.1.6 **Patriot™** is a fiberglass reinforced asphalt roof strip-shingle (with no cut-outs) providing a laminated appearance through an intermittent shadow line with contrasting blend drops for color definition.

4.2 Hip & Ridge Shingles:

- 4.2.1 **Presidential Accessory, Accessory for Hatteras, Shangle Ridge™, Shadow Ridge™, Cedar Crest™, Cedar Crest™ IR, NorthGate Ridge and NorthGate Accessory** are fiberglass reinforced accessory shingles for hip and ridge installation.

4.3 Accessory Starter Strips:

- 4.3.1 **High-Performance Starter** is a starter shingle, measuring 10" x 36", comprised of a fiber glass mat base and ceramic-coated mineral granules embedded in asphalt. These starter shingles are designed for use with **Grand Manor Shangle®, Hatteras™ and Highland Slate™**.
- 4.3.2 **Presidential Starter** is a starter shingle, measuring 13-1/4" x 40" (overall), comprised of a fiber glass mat base and ceramic-coated mineral granules embedded in asphalt with a reinforcement on its underside (for impact resistance considerations). These starter shingles, applied using two (2) overlapping layers, are designed for use with **Presidential Shake™ and Presidential Shake TL™**.
- 4.3.3 **Presidential Starter IR** is a starter shingle, measuring 13-1/4" x 40" (overall), comprised of a fiber glass mat base and ceramic-coated mineral granules embedded in asphalt. These starter shingles, applied using two (2) overlapping layers, are designed for use with **Presidential Shake™ IR**.
- 4.3.4 **SwiftStart® Starter Shingle** is a starter strip for asphalt roof shingles. Its overall size of 15-1/4" x 38-3/4" yields two (2) 7-5/8" x 38-3/4" starter pieces per shingle.
- 4.3.5 **Universal Starter** is a starter shingle, measuring 7" x 36" (overall), comprised of a fiber glass mat base and ceramic-coated mineral granules embedded in asphalt. These starter shingles are designed for use with any CertainTeed shingle measuring 12" x 36" having a weather exposure ≤ 5".
- 4.4 Any of the above listed shingles may be produced in AR (algae resistant) versions.

5. LIMITATIONS:

- 5.1 This is a building code evaluation. Neither NEMO|etc. nor Robert Nieminen, P.E. are, in any way, the Designer of Record for any project on which this Evaluation Report, or previous versions thereof, is/was used for permitting or design guidance unless retained specifically for that purpose.
- 5.2 This Evaluation Report is not for use within FBC HVHZ jurisdictions.
- 5.3 Fire Classification is not part of this Evaluation Report; refer to current Approved Roofing Materials Directory for fire ratings of this product.

5.4 **Wind Classification:**

- 5.4.1 All shingles noted herein are Classified in accordance with **FBC Tables 1507.2.7.1** and **R905.2.6.1** to **ASTM D3161, Class F** and/or **ASTM D7158, Class H**, indicating the shingles are acceptable for use in all wind zones up to $V_{asd} = 150$ mph ($V_{ult} = 194$ mph). Refer to Section 6 for installation requirements to meet this wind rating.
- 5.4.2 **Presidential Accessory, Accessory for Hatteras, Shangle Ridge, Shadow Ridge, Cedar Crest, NorthGate Ridge and NorthGate Accessory hip & ridge shingles** have been evaluated in accordance with **ASTM D3161, Class F**. All except **Shadow Ridge (produced in Oxford, NC), NorthGate Ridge and NorthGate Accessory** require use of **BASF Sonolastic NP 1 adhesive** or **Henkel PL® Polyurethane Roof & Flashing Sealant**, applied as specified in manufacturer's application instructions, for use in wind zones up to $V_{asd} = 150$ mph ($V_{ult} = 194$ mph). Refer to Section 6 for installation requirements to meet this wind rating.
- 5.4.3 **High-Performance Starter, Presidential Starter, Presidential Starter IR, SwiftStart® Starter Shingle and Universal Starter** have been evaluated in accordance with **ASTM D3161, Class F**. Refer to Section 6 for installation requirements to meet this wind rating.
- 5.4.3.1 **High-Performance Starter** shingles are limited to use with **Grand Manor Shangle®, Hatteras™** and **Highland Slate™** shingles.
- 5.4.3.2 **Presidential Starter** shingles must be applied using two (2) overlapping layers and are limited to use with **Presidential Shake™** and **Presidential Shake TL™** shingles.
- 5.4.3.3 **Presidential Starter IR** shingles must be applied using two (2) overlapping layers and are limited to use with **Presidential Shake™ IR** shingles.
- 5.4.3.4 **Universal Starter** shingles are limited to use with CertainTeed shingles measuring 12" x 36" having a weather exposure $\leq 5"$.
- 5.4.4 Classification by **ASTM D7158** applies to **exposure category B or C** and a **building height of 60 feet or less**. Calculations by a qualified design professional are required for conditions outside these limitations. Contact the shingle manufacturer for data specific to each shingle.
- 5.4.4.1 **Analysis in accordance with ASTM D7158** indicates the measured uplift resistance (R_T) for the CertainTeed asphalt Roof shingles listed in Section 4.1.1 through 4.1.6 (*except Presidential Solaris™, Landmark™ Pro Solaris and Landmark™ Solaris Gold/Platinum*) exceeds the calculated uplift force (F_T) at a maximum design wind speed of **$V_{asd} = 150$ mph ($V_{ult} = 194$ mph)** for **residential buildings** located in **Exposure D conditions with no topographical variations (flat terrain)** having a **mean roof height less than or equal to 60 feet**. The shingles are permissible under Code for installation in these conditions using the installation procedures detailed in this Evaluation Report and CertainTeed minimum requirements, subject to minimum codified fastening requirements established within any local jurisdiction, which shall take precedence.
- 5.5 All products in the roof assembly shall have quality assurance audits in accordance with **FAC Rule 61G20-3**.

6. INSTALLATION:

- 6.1 Roof deck, slope, underlayment and fasteners shall comply with **FBC 1507.2 / R905.2** and the shingle manufacturer’s minimum requirements.
- 6.1.1 Underlayment shall be acceptable to **CertainTeed Corporation** and shall hold current Florida Statewide Product Approval, or be Locally Approved per **Rule 61G20-3**, per **FBC Sections 1507.2.3, 1507.2.4 or R905.2.3**.
- 6.2 Installation of asphalt shingles shall comply with the **CertainTeed Corporation** current published instructions, using minimum four (4) nails per shingle in accordance with **FBC 1507.2.7** or **Section R905.2.6** and the minimum requirements herein.
- 6.2.1 Fasteners shall be in accordance with manufacturer’s published requirements, but not less than **FBC 1507.2.6 or R905.2.5**. Staples are not permitted.
- 6.2.2 Where the roof slope exceeds 21 units vertical in 12 units horizontal, use the “Steep Slope” directions.
- 6.3 CertainTeed asphalt shingles are acceptable for use in reroof (tear-off) or recover applications, subject to the limitations set forth in **FBC Section 1511 or R908** and CertainTeed published installation instructions.

6.4 HIGH-PERFORMANCE STARTER:

- 6.4.1 Eaves: For the first starter shingle in each roof corner, use five (5) nails as shown below. All other starter shingles require four (4) nails per shingle. Nails must be of sufficient length to penetrate into the deck 3/4" or through the thickness of the decking, whichever is less. Nails are to be 11 or 12 gauge, corrosion-resistant roofing nails with 3/8" heads. Apply the 10" starter shingle with its factory-applied sealant stripes at the shingle’s lower-most edge and nail firmly into the roof deck as near as possible *(maximum 3") to the eaves edge while avoiding the sealant. With the starter shingle well fastened to the deck and the sealant low on the starter shingle, it can firmly adhere to the first course shingles. *If nailing within 3" is not possible, nail as closely as possible, then lift and adhere the starter shingle to the underlayment and to the supporting structure with CertainTeed FlintBond™ Asphalt Roofing Cement-Caulk Grade, or approved equal.

Rakes: Prior to installation of the field shingles, starter shingles may be applied up the slope along the rake edge with sealant edge placed closest to the rake edge. Fasten as indicated below.

HIGH-PERFORMANCE STARTER SHINGLES

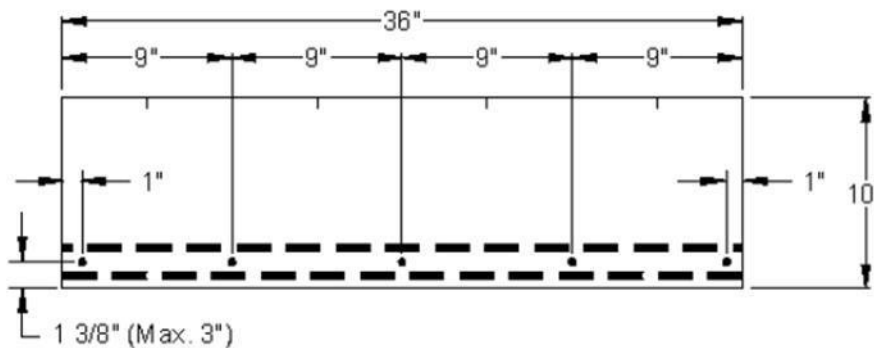

6.5 PRESIDENTIAL STARTER AND PRESIDENTIAL STARTER IR:

6.5.1 General: These shingles shall be applied by using two (2) overlapping layers. Begin application of the bottom/lower layer of starter shingles by cutting and applying a 13-3/4" x 20" piece at the lower left rake/eaves corner overhanging rakes and eaves 1/4" to 3/4". Continue along the eaves with full-size 13-1/4" x 40" starter shingles. Each top/upper starter course shingle shall have its 2" top section removed at the perforations, resulting in 11-1/4" x 40" shingles. The colored granule portion of the "top" starter shingles shall be located nearest the lowermost eave edge. Install the first top/upper starter shingle so that it is flush to the left side and bottom edges of the first bottom/lower starter shingle. This first top/upper starter shingle shall be 11-1/4" x 38". Continue along the eaves with 11-1/4" x 40" top/upper starter shingles ensuring that the lower edges are flush with the lower edges of the bottom/lower layer. Reference the product's wrapper for more specific details.

Eaves: Fasten as shown below. Rakes: After applying the starter shingles at the eaves, but prior to installing the field shingles, starter shingles may be applied up the slope at the rake edge. Fasten as shown below.

Fastening: Four nails are required per shingle. Nails shall be of sufficient length to penetrate into the deck 3/4" or through the thickness of the decking, whichever is less. Nails are to be 11 or 12 gauge, corrosion-resistant roofing nails with 3/8" heads.

Presidential Starter and Presidential IR Starter Shingles

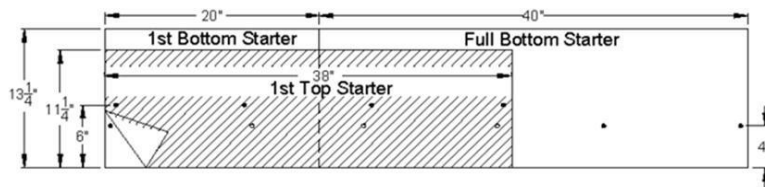

6.6 UNIVERSAL STARTER:

6.6.1 General: While Universal Starter Strip shingles are specifically designed to be used with shingles 36" length and having a weather exposure of ≤ 5", they may be installed beneath shingles of any length if special precautions are taken. **IMPORTANT:** In all cases the end joints of the starter and the first course shingles shall NEVER BE LESS THAN 3-1/2" apart.

Eaves: The sealant on starter courses should face out and lie as close as possible to the eaves edge of the roof. Fasten as described below. Rakes: After applying the starter shingles at the eaves, but prior to installing the field shingles, starter shingles may be applied up the slope at the rake edge with sealant facing out and nearest to the outer roof edge. Fasten as described below.

Fastening: Use four nails on these starter shingles as shown below. The sealant on starter courses shall lie as close as possible to the eaves edge of the roof. Nails shall be of sufficient length to penetrate into the deck 3/4" or through the thickness of the decking, whichever is less. Nails are to be 11 or 12 gauge, corrosion-resistant roofing nails with 3/8" heads.

UNIVERSAL STARTER SHINGLES

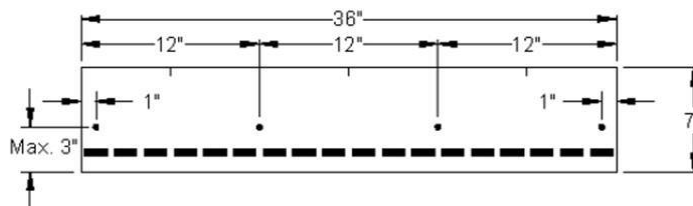

6.7 SWIFTSTART® STARTER SHINGLE:

Fastening: Use four nails, located as shown below

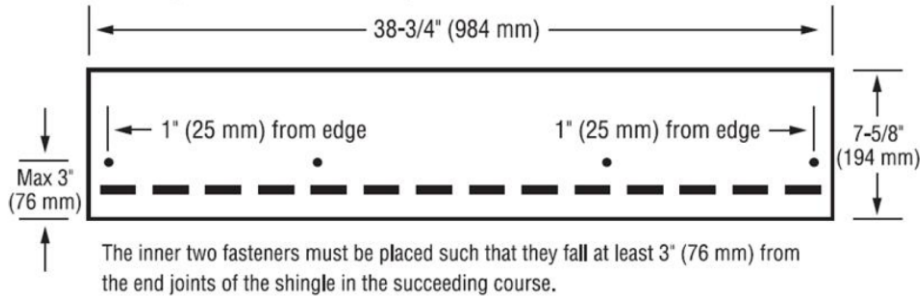

6.8 CT20™, XT™ 25, XT™ 30, XT™ 30 IR:

LOW AND STANDARD SLOPE

ENGLISH

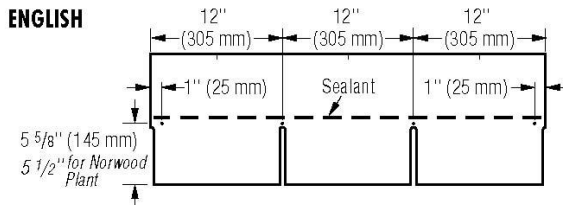

METRIC

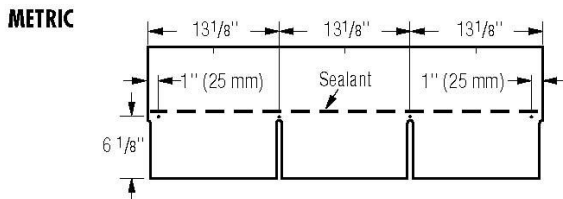

Figure 11-3: Use **four** nails for every full shingle.

STEEP SLOPE

Use **four** nails and six spots of asphalt roofing cement* for every full shingle (Figure 11-4). Asphalt roofing cement meeting ASTM D4586 Type II is suggested.

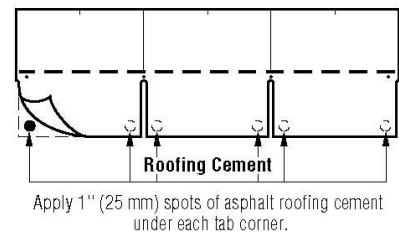

Figure 11-4: Use **four** nails and six spots of asphalt cement on steep slopes.

***CAUTION:** Excessive use of roofing cement can cause shingles to blister.

6.8.1 Hip & Ridge for CT20™, XT™ 25, XT™ 30, XT™ 30 IR: Cut Shingles

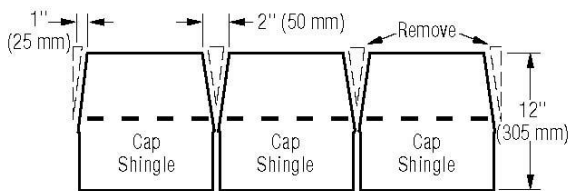

Figure 11-24: Cut tabs, then trim back to make cap shingles (English dimensions shown).

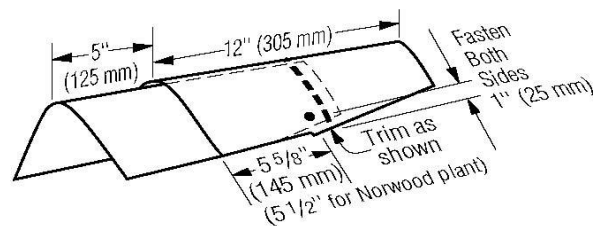

Figure 11-25: Installation of caps along the hips and ridges.

6.8.1.1 For ASTM D3161, Class F performance use BASF "Sonolastic® NP1™" adhesive or Henkel "PL® Polyurethane Roof & Flashing Sealant", in accordance with CertainTeed requirements.

6.9 ARCADIA™:

LOW AND STANDARD SLOPE

Use SIX nails for every full shingle located as shown below.

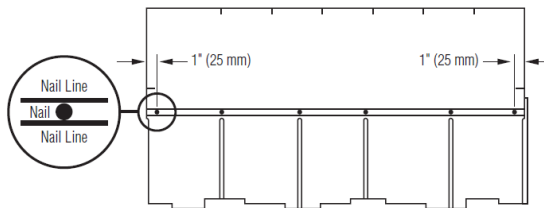

Figure 2: Use six nails for every full shingle.

STEEP SLOPE

Use SIX nails and FOUR spots of asphalt roofing cement for every full shingle as shown below. Apply asphalt roofing cement 1" (25 mm) from edge of shingle. Asphalt roofing cement meeting ASTM D 4586 Type II is suggested.

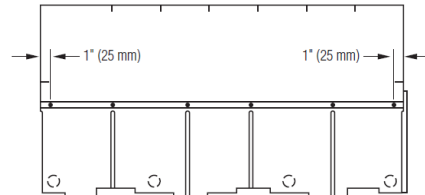
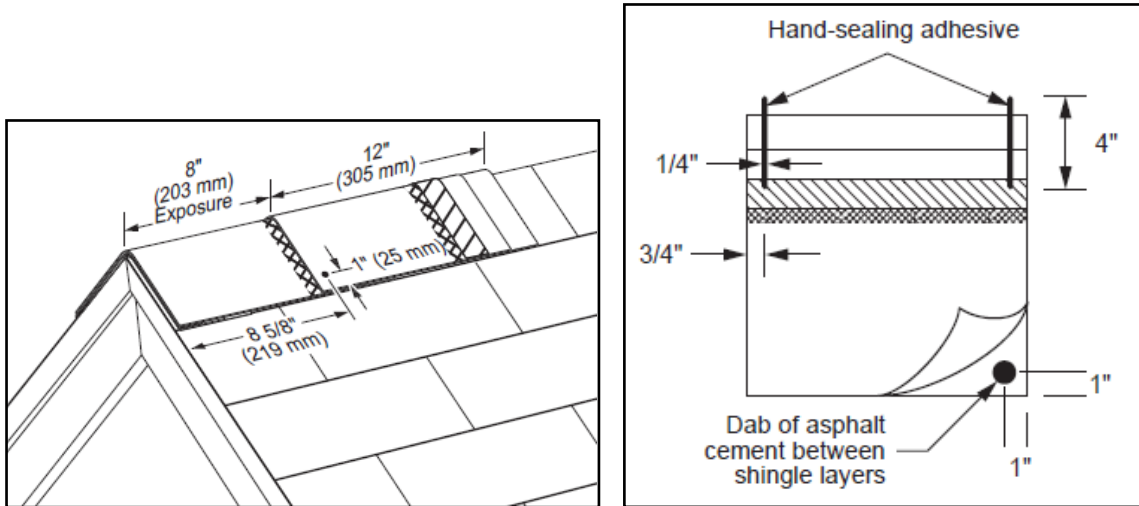

Figure 3: Use six nails and four spots of asphalt roofing cement on steep slopes.

6.9.1 Hip & Ridge for Arcadia™: Cedar Crest™, Cedar Crest™ IR

Use two (2), minimum 1¾-inch long fasteners per shingle. For the starter shingle, place fastener 1-inch from each side edge and about 2-inch up from the starter shingle’s exposed butt edge, ensuring minimum ¾-inch embedment into the deck, or full penetration through the deck. For each full Cedar Crest shingle, place fasteners 8-5/8-inch up from its exposed butt edge and 1-inch from each side edge.

For **ASTM D3161, Class F** performance use BASF “**Sonolastic® NP1™**” adhesive or Henkel “**PL® Polyurethane Roof & Flashing Sealant™**”, in accordance with CertainTeed requirements, to **hand-seal Cedar Crest shingles**. Apply NP 1 or PL adhesive from the middle of the shingle’s raised overlay on the top piece and extending approximately 4-inch along the sides of the headlap along a line ¾ to 1-inch from each side of the shingle’s headlap. Immediately align and apply the overlying shingle, gently pressing tab sides into the adhesive, and install nails. To secure the other side, apply a 1-inch diameter spot of NP 1 or PL adhesive between the shingle layers.



6.10 BELMONT® OR BELMONT® IR:

**Low and Standard Slope
(2:12 to 21:12):**

Use FIVE nails for every full Belmont shingle, located as shown below.

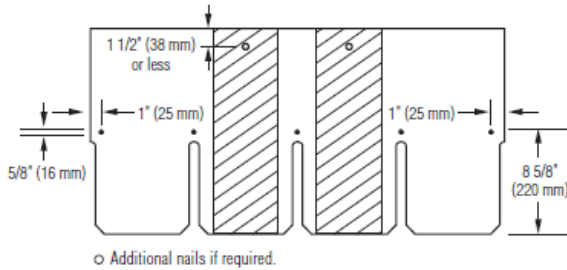

Steep Slope (greater than 21:12):

Use SEVEN nails and EIGHT spots of asphalt roofing cement** for every full Belmont shingle. Apply asphalt roofing cement 1" (25mm) from edge of shingle. See below. Asphalt roofing cement meeting ASTM D4586 Type II is suggested.

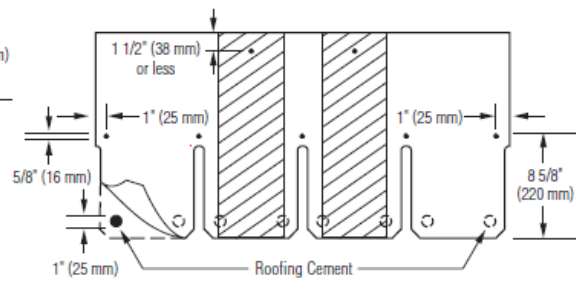

6.10.1 Hip & Ridge for Belmont® or Belmont® IR:

6.10.1.1 Option 1: For Belmont®, refer to instructions herein for Cedar Crest™ or Cedar Crest™ IR hip and ridge shingles. For Belmont® IR, refer to instructions herein for Cedar Crest™ IR hip and ridge shingles.

6.10.1.2 Option 2: For Belmont®: Shangle® Ridge

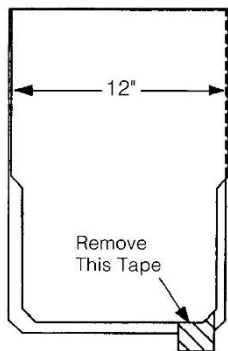

Figure 17-18: Shangle® Ridge.

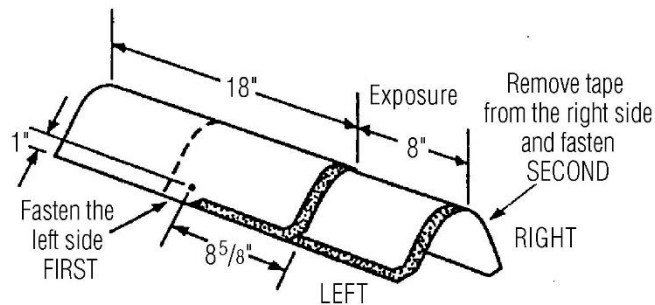

Figure 17-19: Installation of Shangle® Ridge shingles on hips and ridges.

6.10.1.3 For ASTM D3161, Class F performance use BASF “Sonolastic® NP1™” adhesive or Henkel “PL® Polyurethane Roof & Flashing Sealant”, in accordance with CertainTeed requirements.

6.11 CARRIAGE HOUSE SHANGLE® AND GRAND MANOR SHANGLE®:

LOW AND STANDARD SLOPE

Use **five** nails for every full Shangle.

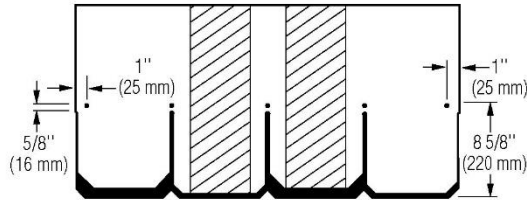

Figure 17-4: Use five nails for every full Grand Manor Shangle, Carriage House Shangle, or Centennial Slate.

STEEP SLOPE

Use **seven** nails and three spots of asphalt roofing cement for every full Grand Manor Shangle. Use **five** nails and three spots of asphalt roofing cement for every full Carriage House Shangle and Centennial Slate. Apply asphalt roofing cement 1" (25 mm) from edge of shingle (Figure 17-5). Asphalt roofing cement meeting ASTM D4586 Type II is suggested.

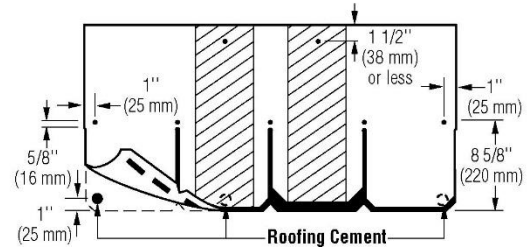
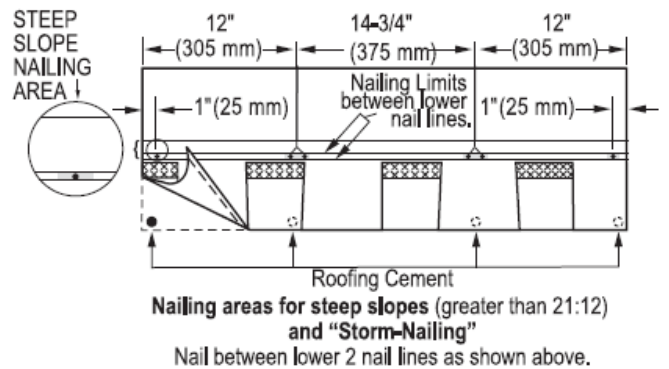
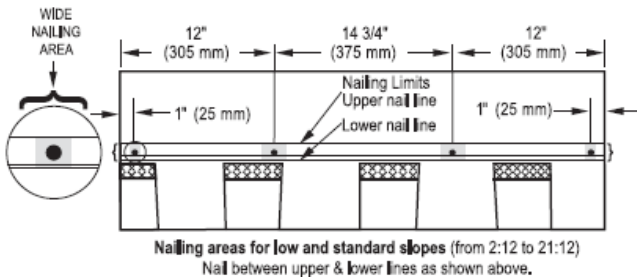

Figure 17-5: When installing Grand Manor Shangles on steep slopes, use seven nails and three spots of asphalt roofing cement.

6.11.1 **Hip & Ridge for Carriage House Shangle® and Grand Manor Shangle:** Refer to instructions herein for Shangle® Ridge hip and ridge shingles

6.12 LANDMARK™, LANDMARK™ IR, LANDMARK™ PRO, LANDMARK™ PRO SOLARIS, LANDMARK™ PREMIUM, LANDMARK™ SOLARIS, LANDMARK™ SOLARIS IR, LANDMARK™ SOLARIS GOLD/PLATINUM OR NORTHGATE:



6.12.1 **Hip & Ridge for Landmark™, Landmark™ IR, Landmark™ Pro, Landmark™ Pro Solaris, Landmark™ Premium, Landmark™ Solaris, Landmark™ Solaris IR, Landmark™ Solaris Gold/Platinum or NorthGate:**

6.12.1.1 **Option 1:** Shadow Ridge™ or NorthGate Accessory

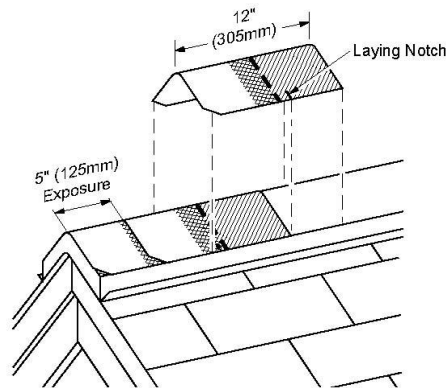
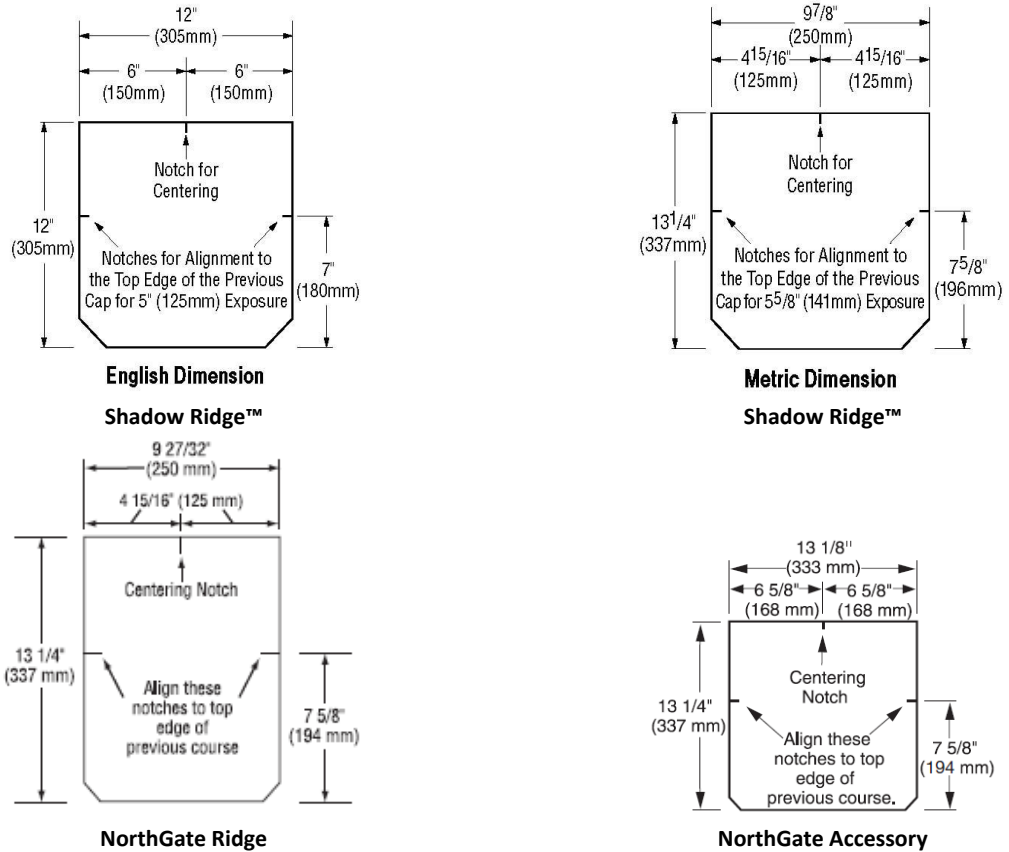

Figure 13-20: Use laying notches to center shingles on hips and ridges, and to locate the correct exposure.

6.12.1.2 Optional for Shadow Ridge™ *produced in Oxford, NC*: For ASTM D3161, Class F performance use BASF “Sonolastic® NP1™” adhesive or Henkel “PL® Polyurethane Roof & Flashing Sealant”, in accordance with CertainTeed requirements.

6.12.1.3 **Option 2:** Refer to instructions herein for Cedar Crest™, Cedar Crest™ IR hip and ridge shingles.

6.13 LANDMARK™ TL:

LANDMARK TL

LANDMARK TL

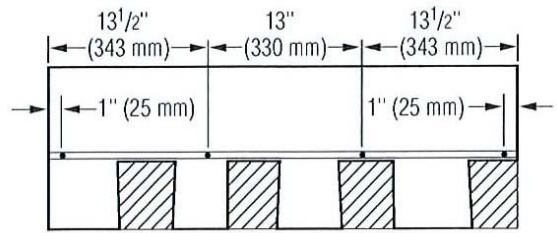

Figure 13-4: Use four nails for every full shingle.

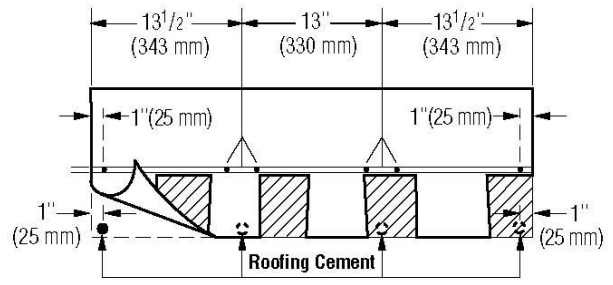

Figure 13-5: Use six nails and four spots of asphalt roofing cement on steep slopes.

6.13.1 **Hip & Ridge for Landmark™ TL:** Refer to Option 1 or 2 for Landmark™.

6.14 PRESIDENTIAL SHAKE™, PRESIDENTIAL SHAKE™ IR, PRESIDENTIAL SHAKE TL™, PRESIDENTIAL SOLARIS™:

LOW AND STANDARD SLOPE:

For low and standard slopes, use five nails for each full Presidential shingle as shown below.

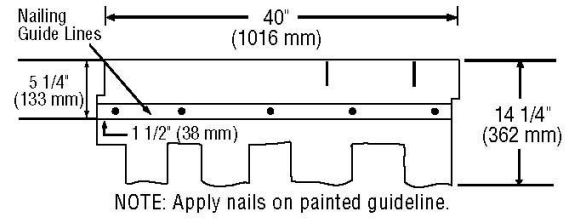

Figure 16-6: Fastening Presidential and Presidential TL Shake shingles on low and standard slopes.

STEEP SLOPE:

For steep slopes, use nine nails for each full Presidential shingle and apply 1" diameter spots of asphalt roofing cement under each shingle tab. After applying 5 nails in between the nailing guide lines, apply 4 nails 1" above tab cutouts making certain tabs of overlying shingle cover nails.

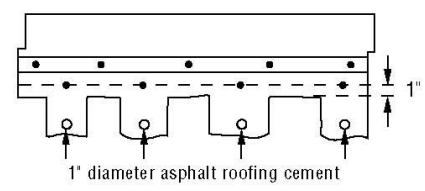

Figure 16-7: Fastening Presidential and Presidential TL Shake shingles on steep slopes.

6.14.1 **Hip & Ridge for Presidential Shake™, Presidential Shake™ IR, Presidential Shake TL™, Presidential Solaris™:**

6.14.1.1 **Option 1:** Presidential Accessory

PRESIDENTIAL ACCESSORY

Presidential accessory shingles can be used for covering hips and ridges. Apply shingles up to the ridge (expose no more than 7" from the bottom edge of the "tooth." Fasten each accessory with two fasteners. The fasteners must be 1 3/4" long or longer, so they penetrate either 3/4" into the deck or completely through the deck. Presidential accessory comes in two different sizes: Accessory produced in Birmingham, AL is 12" x 12"; Portland, OR produces 9 7/8" x 13 1/4" accessory.

6.14.1.2 For **ASTM D3161, Class F** performance use BASF "Sonolastic® NP1™" adhesive or Henkel "PL® Polyurethane Roof & Flashing Sealant", in accordance with CertainTeed requirements.

6.14.1.3 **Option 2:** Refer to instructions herein for **Cedar Crest™, Cedar Crest™ IR** hip and ridge shingles.

6.15 HATTERAS™:

LOW, STANDARD AND STEEP SLOPE:

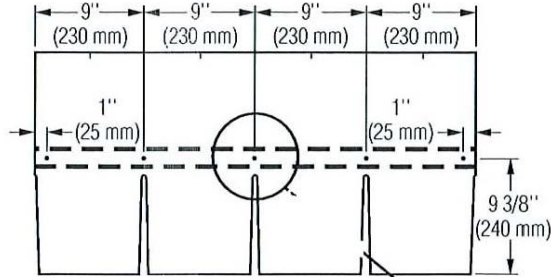

Figure 15-3: Fastening Hatteras Shingles on Low and Standard Slopes

For low and standard slopes, use five nails for each full Hatteras shingle as shown above.

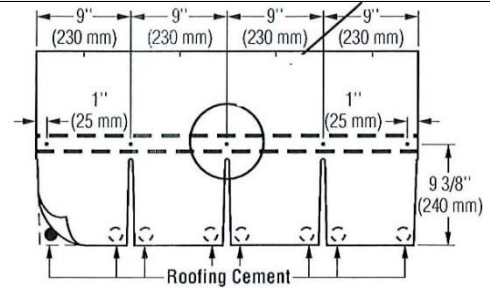

Figure 15-4: Fastening Hatteras Shingles on Steep Slopes

For steep slopes, use five nails and eight spots of asphalt roofing cement for each full Hatteras shingle as shown above. Apply 1" (25mm) diameter spots of roofing cement (ASTM D 4586 Type II suggested) under each tab corner. Press shingle into place; do not expose cement.

CAUTION: Too much roofing cement can cause shingles to blister.

6.15.1 Hip & Ridge for Hatteras™:

6.15.1.1 Option 1: Accessory for Hatteras

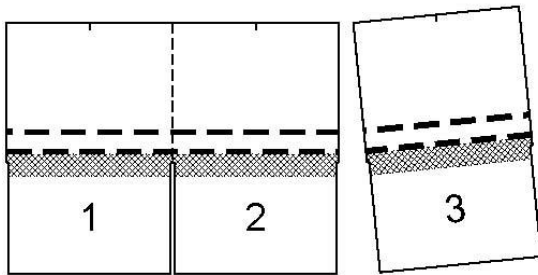
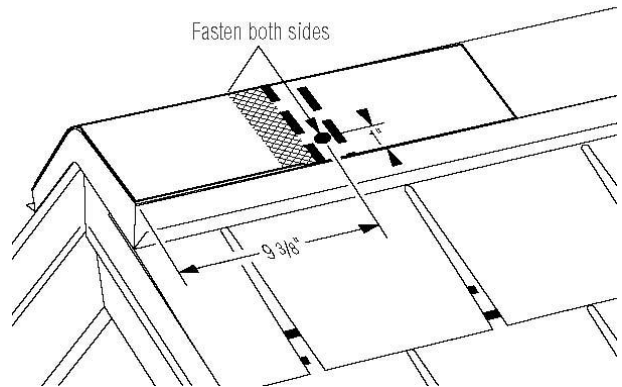

Figure 15-14: 18 three-piece units separate to make 54 Hatteras Accessory shingles.



6.15.1.2 Option 2: Cut Hatteras Shingles

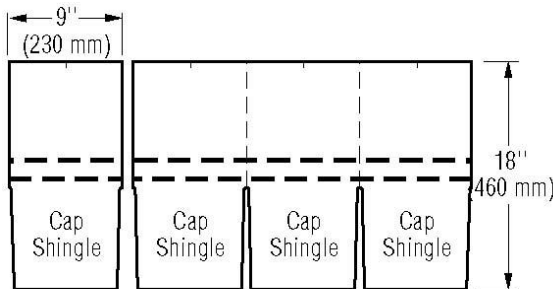

Figure 15-20: Cut Hatteras shingles to make cover cap.

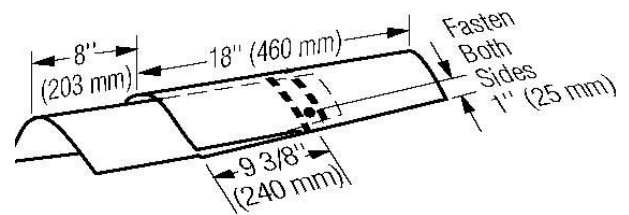

Figure 15-21: Installation of caps along hips and ridges.

6.15.1.3 For ASTM D3161, Class F performance use BASF "Sonolastic® NP1™" adhesive or Henkel "PL® Polyurethane Roof & Flashing Sealant", in accordance with CertainTeed requirements.

6.16 HIGHLAND SLATE™, HIGHLAND SLATE™ IR:

LOW AND STANDARD SLOPE:

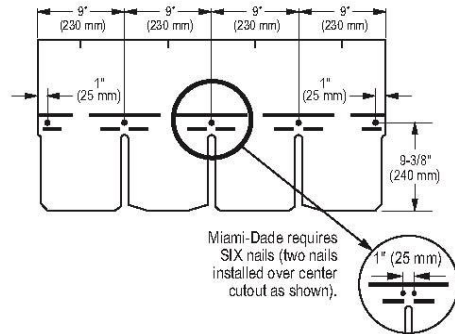

Figure 11-3: Use FIVE nails for every Highland Slate shingle.

STEEP SLOPE:

Use FIVE nails and EIGHT spots of asphalt roofing cement* for each full Highland Slate shingle. For Miami-Dade, SIX nails are required. Apply 1" diameter spots of asphalt roofing cement under each tab corner. Asphalt roofing cement meeting ASTM D4586 Type II is suggested.

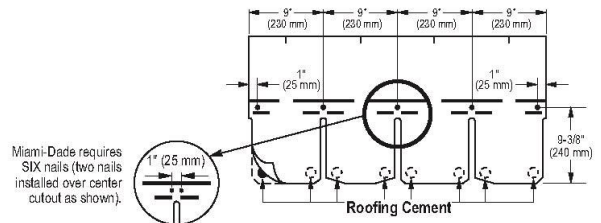

Figure 11-3A: Use FIVE nails and eight spots of asphalt roofing cement under each tab corner.

*CAUTION: Excessive use of roofing cement can cause shingles to blister.

6.16.1 **Hip & Ridge for Highland Slate™, Highland Slate™ IR:** Refer to instructions herein for Cedar Crest™, Cedar Crest™ IR or Shangle Ridge™ hip and ridge shingles.

6.17 PATRIOT™:

LOW AND STANDARD SLOPE

Use FOUR nails for every full shingle located as shown below.

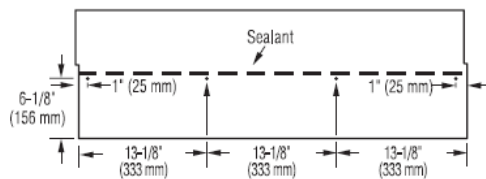

STEEP SLOPE

Use FOUR nails and four spots of asphalt roofing cement for every full shingle as shown below. Asphalt roofing cement meeting ASTM D4586 Type II is suggested. Apply 1" (25 mm) spots of asphalt roofing cement as shown.

CAUTION: Excessive use of roofing cement can cause shingles to blister.

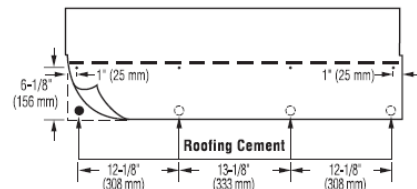

6.17.1 **Hip & Ridge for Patriot™:** Refer to instructions herein for Cedar Crest™, Cedar Crest™ IR, Shadow Ridge™, NorthGate or Shangle Ridge™ hip and ridge shingles.

7. LABELING:

- 7.1 Each unit shall bear a permanent label with the manufacturer's name, logo, city, state and logo of the Accredited Quality Assurance Agency noted herein.
- 7.2 Asphalt shingle wrappers shall indicate compliance with one of the required classifications detailed in **FBC Table 1507.2.7.1 / R905.2.6.1**.

8. BUILDING PERMIT REQUIREMENTS:

As required by the Building Official or Authority Having Jurisdiction to properly evaluate the installation of this product.

9. MANUFACTURING PLANTS:

Contact the named QA entity for information on which plants produce products covered by **Florida Rule 61G20-3** QA requirements.

10. QUALITY ASSURANCE ENTITY:

UL LLC – QUA9625; (414) 248-6409; karen.buchmann@us.ul.com

- END OF EVALUATION REPORT -