

SINGLE HUNG - LARGE MISSILE IMPACT

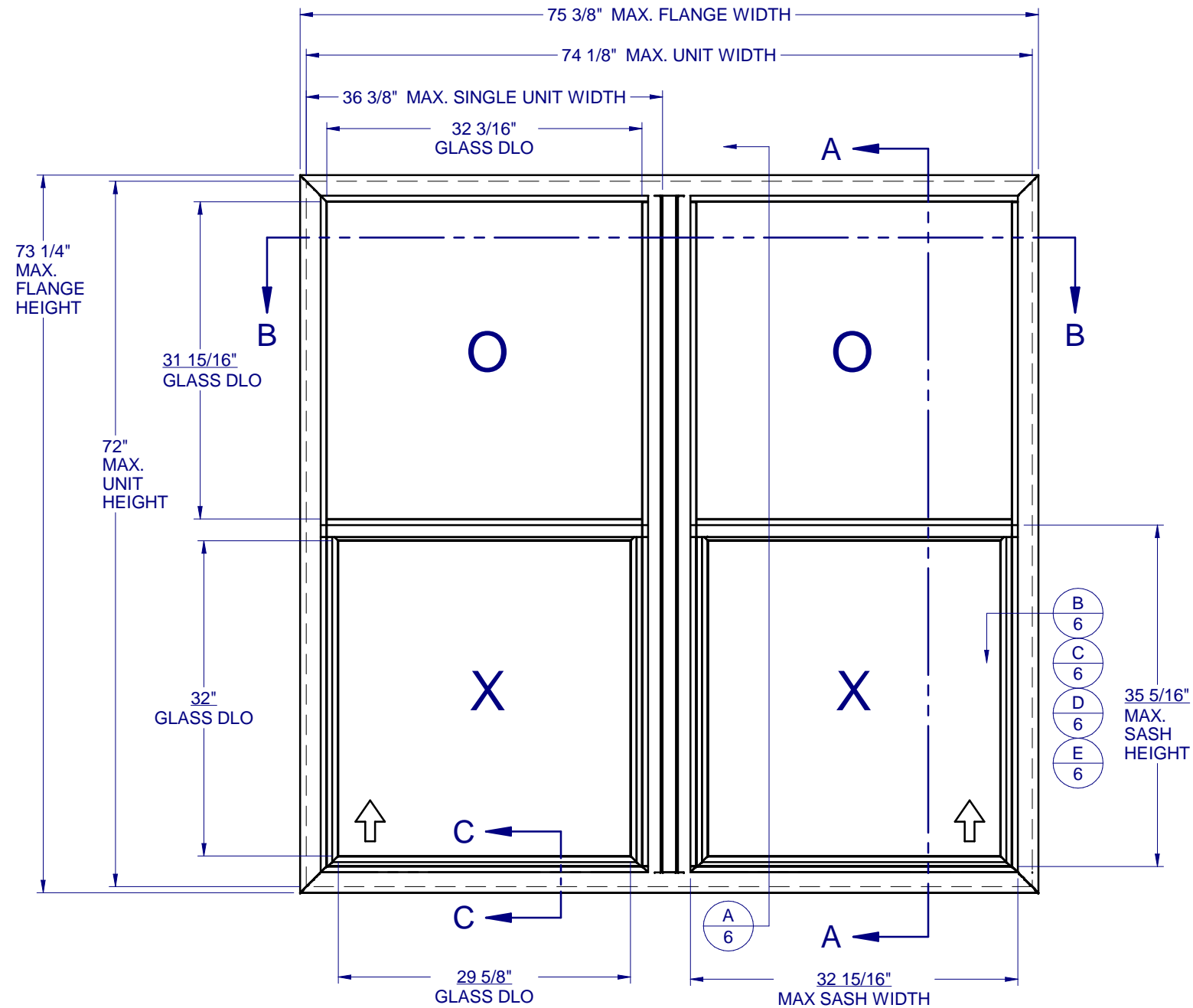

GENERAL NOTES:

1. THE PRODUCT SHOWN HEREIN IS DESIGNED AND MANUFACTURED TO COMPLY WITH THE FLORIDA BUILDING CODE (FBC), CURRENT EDITION INCLUDING THE HIGH VELOCITY HURRICANE ZONE (HVHZ) AND IS RATED FOR WIND ZONE 4 MISSILE LEVEL D IMPACT USE AS DEFINED IN ASTM E 1996 PER THE FBC.
2. GLAZING OPTIONS: (SEE SHEET 2)
3. CONFIGURATIONS: "O/X - O/X".
4. DESIGN PRESSURE RATING:
 - NEGATIVE DESIGN LOADS BASED ON, TESTED PRESSURE AND GLASS TABLES ASTM E-1300-04e01/09.
 - POSITIVE DESIGN LOADS BASED ON, TESTED PRESSURE, WATER INFILTRATION TEST PRESSURE AND GLASS TABLES ASTM E-1300-04e01/09.
5. ANCHORAGE: THE 33 1/3% STRESS INCREASE HAS NOT BEEN USED IN THE DESIGN OF THIS PRODUCT. SEE SHEET 6 FOR ANCHOR DETAILS. WINDLOAD DURATION FACTOR Cd=1.6 WAS USED FOR WOOD ANCHOR CALCULATIONS.
6. PRODUCT APPROVED FOR IMPACT RESISTANCE. SHUTTERS ARE NOT REQUIRED. THE IMPACT ROTARY LOCKS ARE INTENDED TO BE LEFT UNLATCHED DURING NORMAL OPERATION OF THIS PRODUCT, BUT MUST BE ENGAGED PRIOR TO EXPOSURE TO HURRICANE WINDS AND FLYING DEBRIS.
7. ALL FRAMES AND VENTS FULLY WELDED. SMALL JOINT SEAM SEALANT USED AT FIXED MEETING RAIL, INTERNAL MULL ENDS AND JAMBS.
8. SERIES / MODEL DESIGNATION SH-8100 CONTINUOUS FRAME.
9. THE DESIGNATION X AND O STAND FOR THE FOLLOWING:
X = OPERABLE SASH, O = FIXED SASH
10. SECTION CALLOUTS APPLY TO ALL ELEVATIONS IN A SIMILAR LOCATION.
11. EXTERNAL WEEP SLOT = 1/4" x 1-1/4" LOCATED 4" FROM BOTH ENDS.



8100 PVC SINGLE HUNG IMPACT

PROPRIETARY AND CONFIDENTIAL
 THE INFORMATION CONTAINED IN THIS DRAWING IS THE SOLE PROPERTY OF CUSTOM WINDOW SYSTEMS, INC. ANY REPRODUCTION IN PART OR AS A WHOLE WITHOUT THE WRITTEN PERMISSION OF CUSTOM WINDOW SYSTEMS, INC IS PROHIBITED.

FLORIDA APPROVAL NO.:
5823



9/13/2023

LUCAS A. TURNER, P.E.
 FL PE # 58201
 Turner Engineering & Consulting, Inc.
 2428 Old Natchez Trc Trl
 Camden, TN 38320
 PH. 941-380-1574

SHEET DESCRIPTION:

GENERAL NOTES AND ELEVATIONS

DRAWN BY: MCS	DATE: 8/24/2023
DWG #: CWS-491	REV.: F
SCALE: 1:15	SHEET 1 OF 6

TABLE OF CONTENTS

GENERAL NOTES & ELEVATIONS.....	1
GLAZING DETAIL.....	2
SECTION VIEWS.....	3
BOM & EXTRUSIONS.....	4
ANCHOR SCHEDULE & NOTES.....	5
INSTALLATION DETAILS.....	6

LOCATION	MAX. UNIT SIZE	DESIGN PRESSURE RATING	IMPACT RATING
NON-HVHZ	74-1/8" x 72"	+/- 65 PSF	LARGE MISSILE IMPACT
HVHZ		+/- 67.5 PSF	



1900 SW 44TH AVE.
OCALA, FLORIDA 34474
WWW.CWS.CC

**8100 PVC
SINGLE HUNG
IMPACT**

PROPRIETARY AND CONFIDENTIAL
THE INFORMATION CONTAINED IN THIS DRAWING IS THE SOLE PROPERTY OF CUSTOM WINDOW SYSTEMS, INC. ANY REPRODUCTION IN PART OR AS A WHOLE WITHOUT THE WRITTEN PERMISSION OF CUSTOM WINDOW SYSTEMS, INC IS PROHIBITED.

FLORIDA APPROVAL NO.:

5823

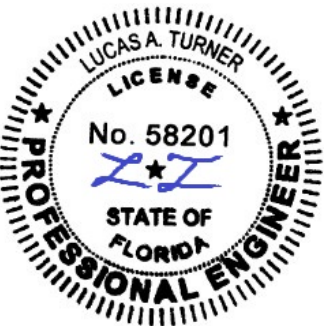

9/13/2023

LUCAS A. TURNER, P.E.
FL PE # 58201
Turner Engineering & Consulting, Inc.
2428 Old Natchez Trc Trl
Camden, TN 38320
PH. 941-380-1574

SHEET DESCRIPTION:

GLAZING DETAIL

DRAWN BY:	DATE:
MCS	8/24/2023
DWG #:	REV.:
CWS-491	F
SCALE:	SHEET
1:1	2 OF 6

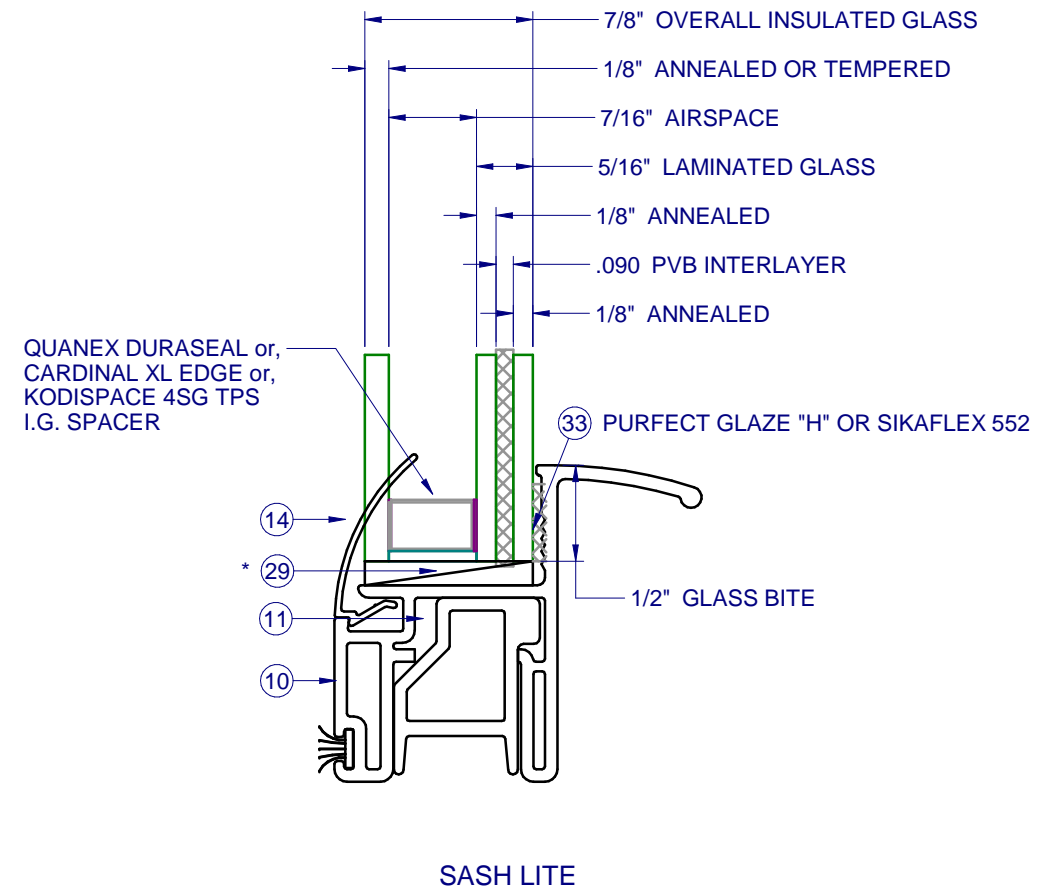
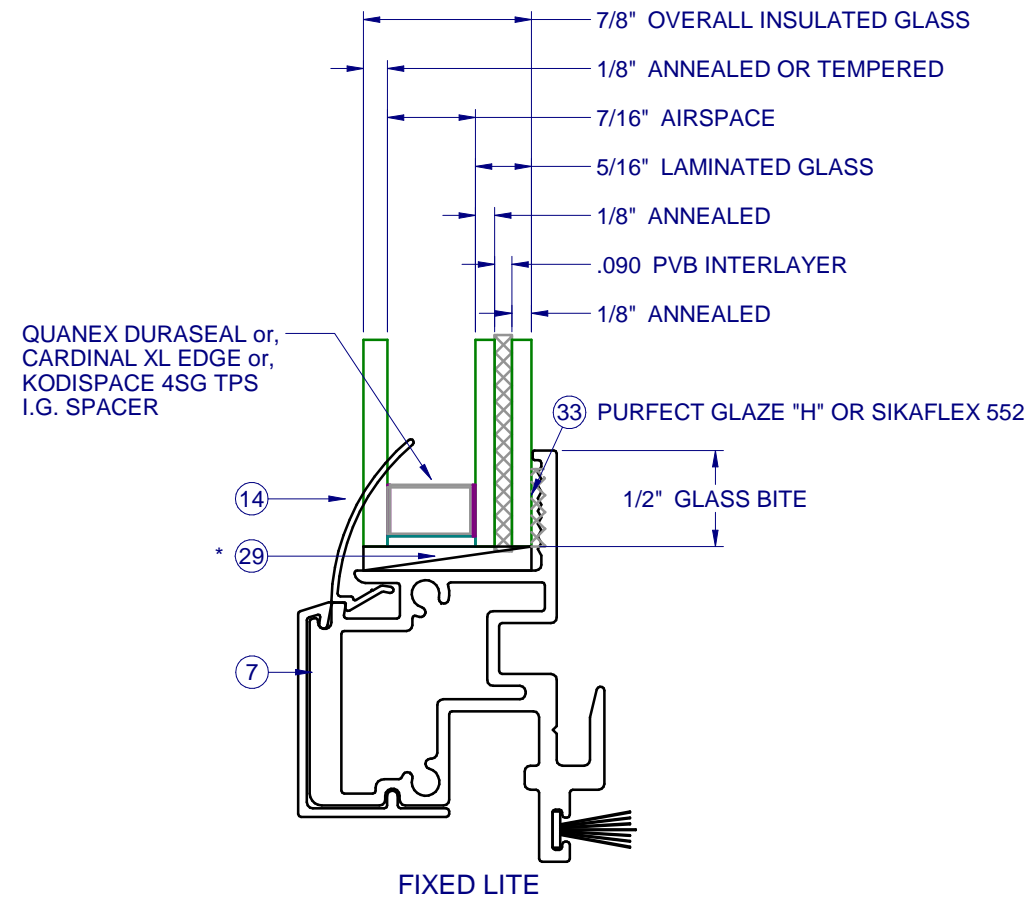

* SETTING BLOCKS PER FBC 2411.3.3.1



1900 SW 44TH AVE.
OCALA, FLORIDA 34474
WWW.CWS.CC

**8100 PVC
SINGLE HUNG
IMPACT**

PROPRIETARY AND CONFIDENTIAL
THE INFORMATION CONTAINED IN
THIS DRAWING IS THE SOLE
PROPERTY OF CUSTOM WINDOW
SYSTEMS, INC. ANY
REPRODUCTION IN PART OR AS A
WHOLE WITHOUT THE WRITTEN
PERMISSION OF CUSTOM WINDOW
SYSTEMS, INC IS PROHIBITED.

FLORIDA APPROVAL NO.:

5823

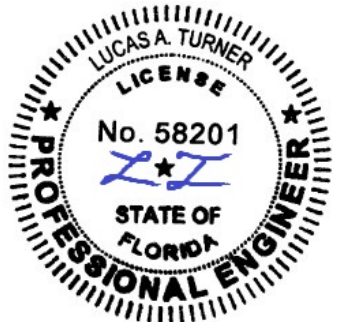

9/13/2023

LUCAS A. TURNER, P.E.
FL PE # 58201
Turner Engineering &
Consulting, Inc.
2428 Old Natchez Trc Trl
Camden, TN 38320
PH. 941-380-1574

SHEET DESCRIPTION:

SECTION VIEWS

DRAWN BY:	DATE:
MCS	8/24/2023
DWG #:	REV.:
CWS-491	F
SCALE:	SHEET
1:2	3 OF 6

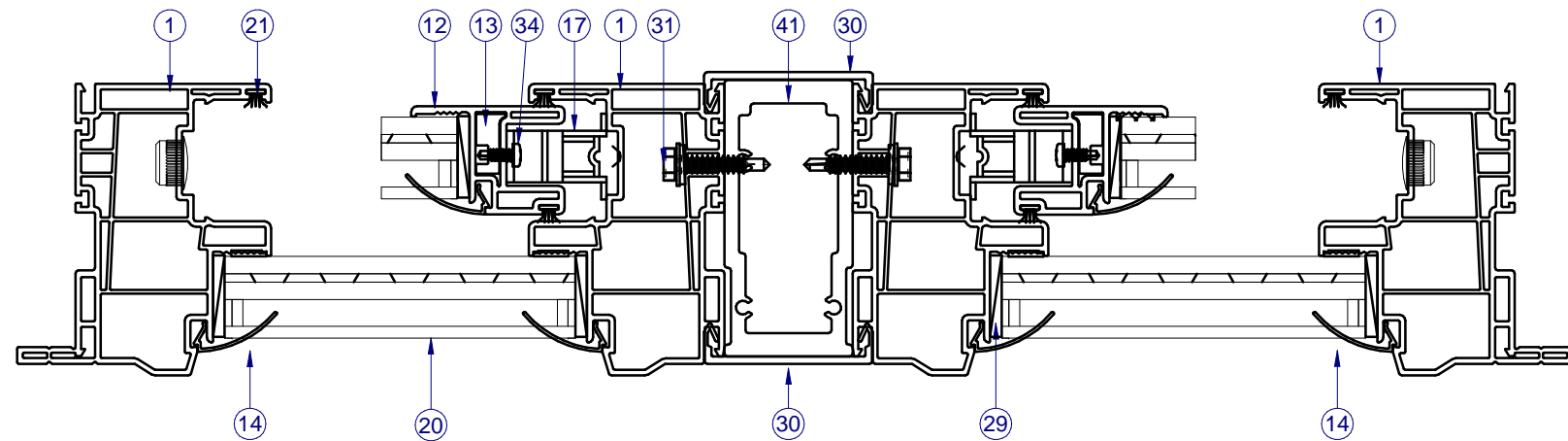

SECTION VIEW B-B

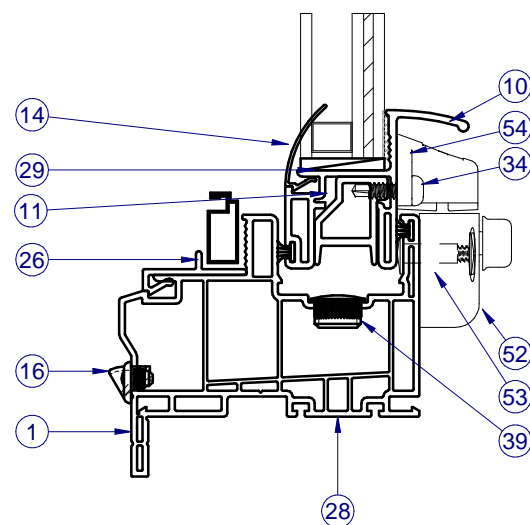
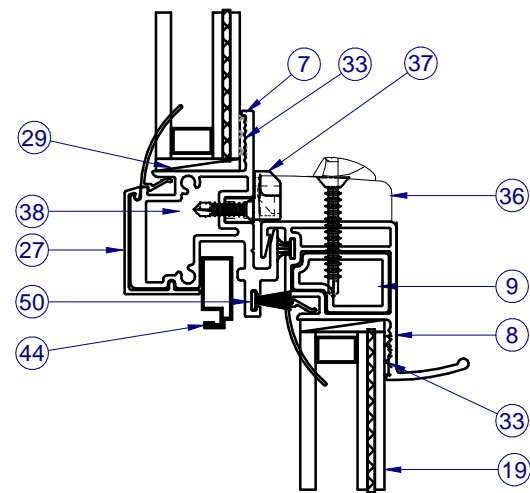
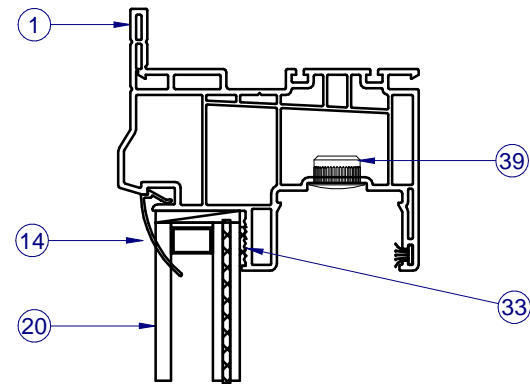

SECTION VIEW A-A

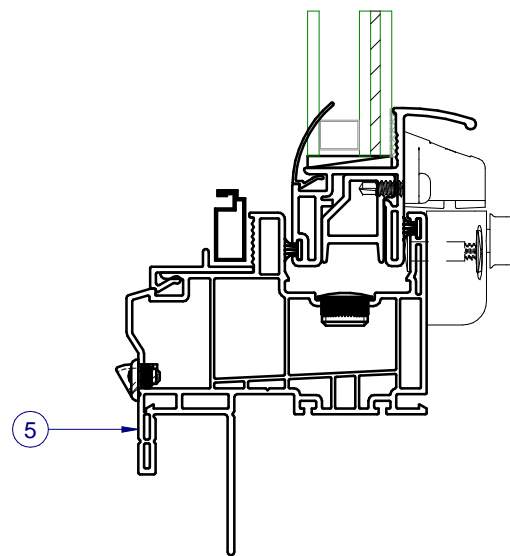

SECTION VIEW C-C
ALTERNATE FIN FRAME

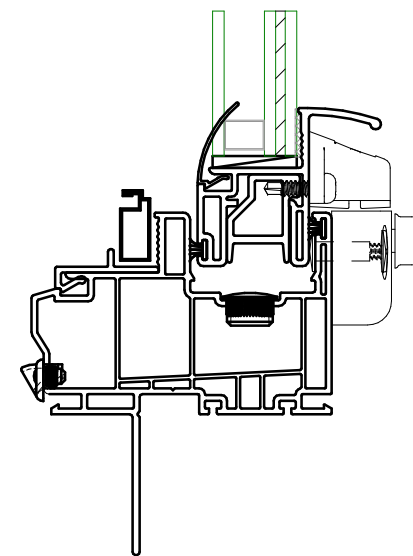

SECTION VIEW C-C
ALTERNATE FIN ONLY FRAME

ITEMS NOT SHOWN FOR CLARITY:
6, 15, 18, 25, 32 42, 45, 48

PARTS LIST			
ITEM	PART #	DESCRIPTION	MATERIAL
1	H-6222	Main Frame, Flg,	Vinyl
5	H-6231	Frame, Fin	Vinyl
6	S-5087	SASH STOP	Vinyl
7	H-2121	Alum. Fixed Meet. Rail	Alum
8	H-6224	Sash Top Rail	Vinyl
9	H-2124	Reinforcement for STR	Alum
10	H-6223	Sash Bottom Rail	Vinyl
11	H-2123	Reinforcement for SBR	Alum
12	H-6225	Sash Side Rail	Vinyl
13	S-2129	Reinforcement for SSR	Alum
14	S-6237	Glazing Bead	Vinyl
15	P-4056	SASH CAM FOR PVC WINDOW	Plastic
16	P-4479	Weep Housing & Flap Assm.	Plastic
17		Sash Balance	Steel
18	P-3295	Take Out Clip	Steel
19	Sash	SEE SHEET 2	GLASS
20	Fixed	SEE SHEET 2	GLASS
21	P-3305	Wstp., 0.270 x 0.187 High Density	Nylon
22	P-4638	#8 x 2-1/2 PH Mod. Truss, Type A,	Steel
23		#10 x 1 1/2" Panhead SMS	Steel
25	S-6227	Screen Support	Vinyl
26	S-6226	Screen Catch	Vinyl
27	S-6228	Fixed Rail Cover	Vinyl
29	P-5612	Setting Block, .12 x 1 x 2	Rubber
30	S-6018	Mullbar Cover	Vinyl
31	P-3767	#10 x 1 Hex Head Tek	Steel
32	P-3342	Seam Sealer, SM-5504	
33		SikaFlex 552 or Purfect Glaze "H"	
34	P-3541	#8 x 1/2 Quadrex PH TEK	Steel
35	P-4051	#8 x 1 1/4" PH Flat Tek	Steel
36	P-3783	Lock	Steel
37	P-4069	Keeper	Steel
38	P-3539	#8 x 3/4" Phillips Square SMS	Steel
39	P-5588	Hole Plug	Plastic
41	H-2127	Internal Mullbar	Alum
44	P-3218	Screen frame	Alum
45	P-4754	SCREEN CORNER KEY (Rollform	Plastic
46	P-5576	Screen Spline, .125" Black PE Rib	Rubber
47	P-3195	Screen Spring	Steel
48	P-4755	SCREEN CORNER KEY (Rollform	Alum
49	P-4770	30" BetterVue Insect Screen, 18 x	Fiberglass
50	P-4959	Wstp., 0.420 x 0.187 back	Nylon
51	P-3541	#8 x 1/2, Pan Head, Tek	Steel
52	P-4951	SWEEP LOCK	
53	P-4633	Binding Post and Screw	
54	P-4952	SWEEP KEEPER	

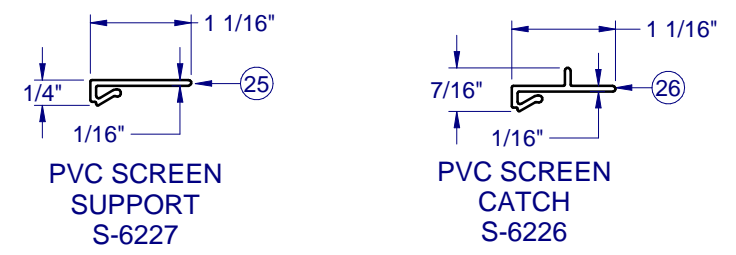
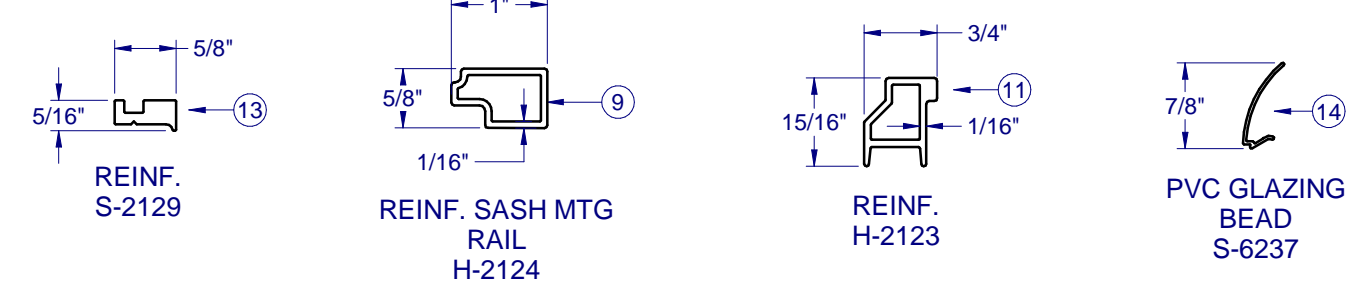
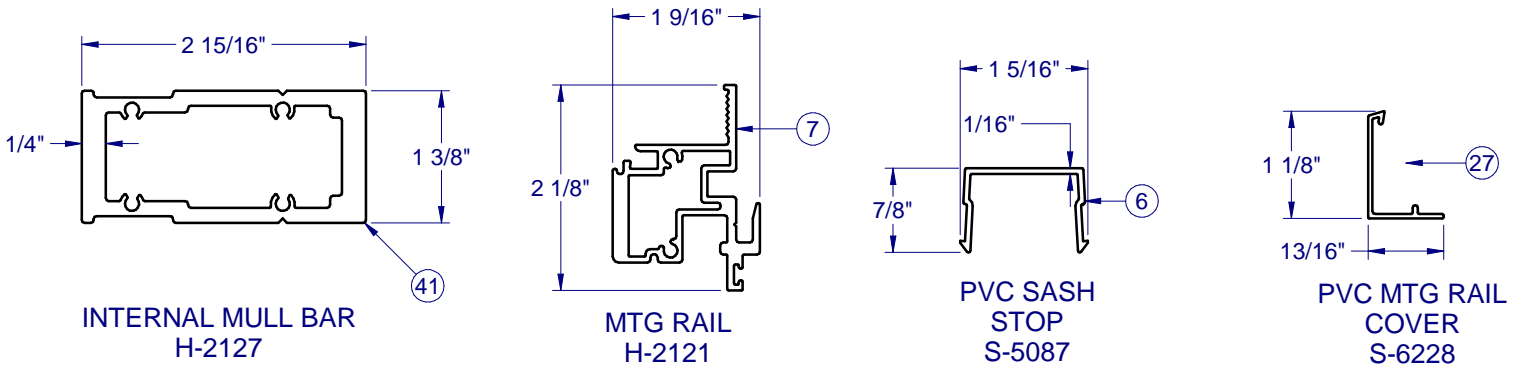
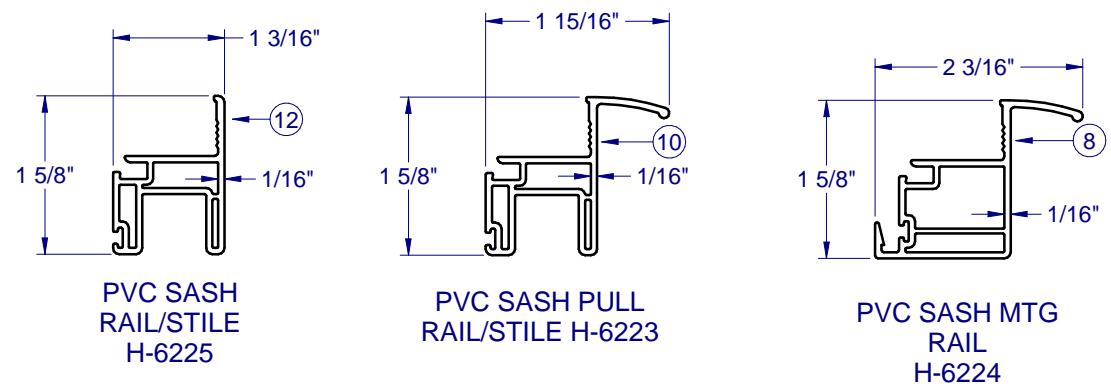
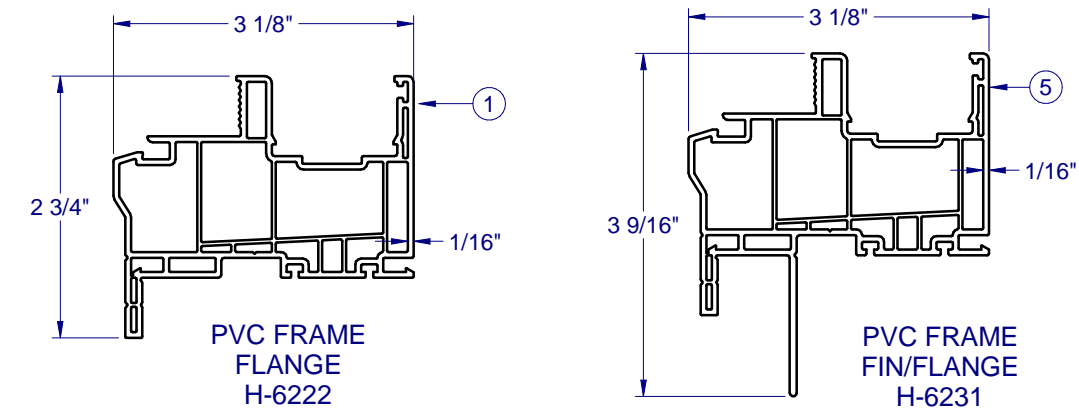

LINE ITEMS NOT USED:
42-43

NOTE: ALL ALUMINUM EXTRUSIONS ARE 6063-T6 UNLESS OTHERWISE NOTED.

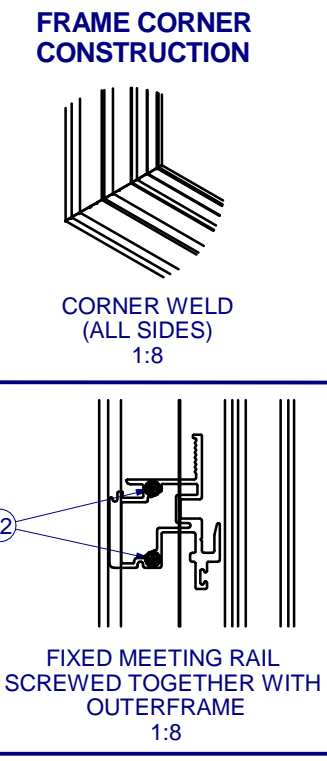

CWS
1900 SW 44TH AVE.
OCALA, FLORIDA 34474
WWW.CWS.CC

8100 PVC SINGLE HUNG IMPACT

PROPRIETARY AND CONFIDENTIAL
THE INFORMATION CONTAINED IN THIS DRAWING IS THE SOLE PROPERTY OF CUSTOM WINDOW SYSTEMS, INC. ANY REPRODUCTION IN PART OR AS A WHOLE WITHOUT THE WRITTEN PERMISSION OF CUSTOM WINDOW SYSTEMS, INC IS PROHIBITED.

FLORIDA APPROVAL NO.:
5823

9/13/2023

LUCAS A. TURNER, P.E.
FL PE # 58201
Turner Engineering & Consulting, Inc.
2428 Old Natchez Trc Trl
Camden, TN 38320
PH. 941-380-1574

SHEET DESCRIPTION:
BOM AND EXTRUSIONS

DRAWN BY: MCS	DATE: 8/24/2023
DWG #: CWS-491	REV.: F
SCALE: 1:2	SHEET 4 OF 6

**8100 PVC
SINGLE HUNG
IMPACT**

PROPRIETARY AND CONFIDENTIAL
THE INFORMATION CONTAINED IN
THIS DRAWING IS THE SOLE
PROPERTY OF CUSTOM WINDOW
SYSTEMS, INC. ANY
REPRODUCTION IN PART OR AS A
WHOLE WITHOUT THE WRITTEN
PERMISSION OF CUSTOM WINDOW
SYSTEMS, INC IS PROHIBITED.

FLORIDA APPROVAL NO.:
5823



9/13/2023

LUCAS A. TURNER, P.E.
FL PE # 58201
Turner Engineering &
Consulting, Inc.
2428 Old Natchez Trc Trl
Camden, TN 38320
PH. 941-380-1574

SHEET DESCRIPTION:

**ANCHOR SCHEDULE AND
NOTES**

DRAWN BY: MCS	DATE: 8/24/2023
DWG #: CWS-491	REV.: F
SCALE: 1:20	SHEET 5 OF 6

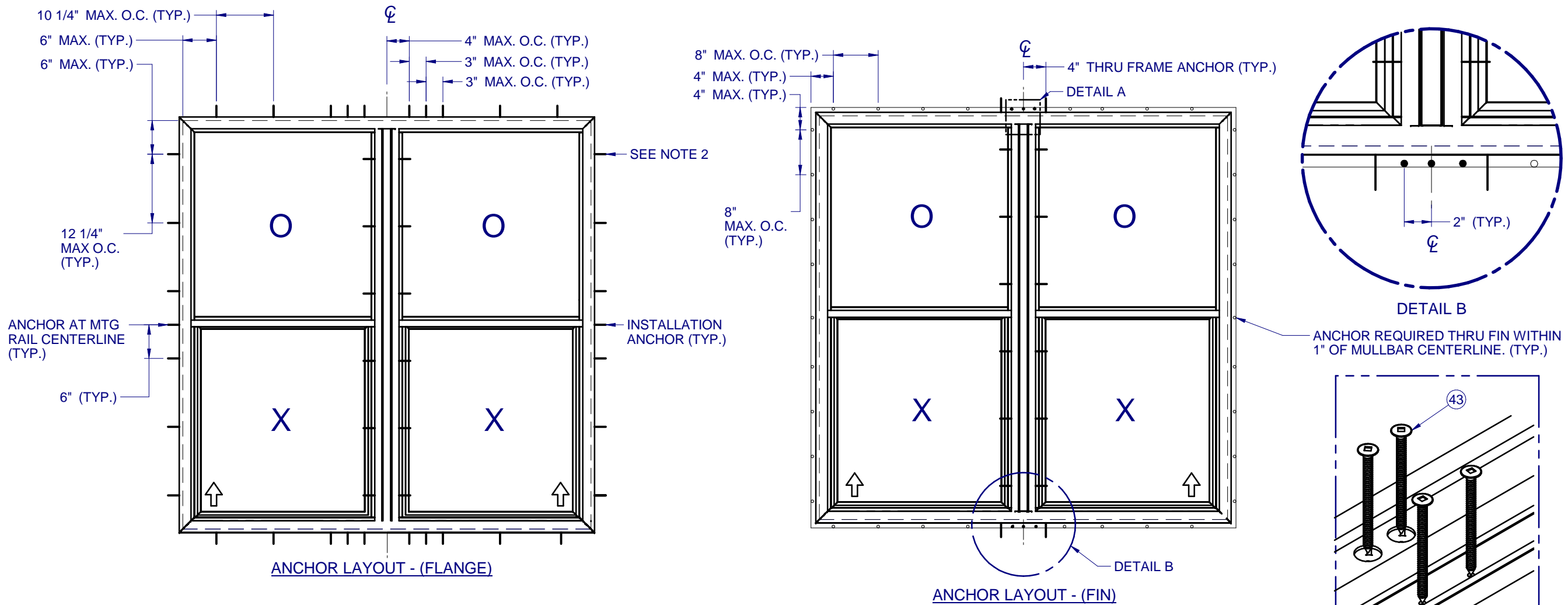

NOTES:

1. INSTALL ONE ANCHOR AT EACH INSTALLATION LOCATION. SILL ANCHOR SPACING SAME AS HEAD.
2. SHIM AS REQ AT EACH INSTALLATION ANCHOR USING LOAD BEARING SHIMS. MAX. ALLOWABLE SHIM STACK TO BE 1/4". USE SHIMS WHERE SPACE GREATER THAN 1/16" IS PRESENT. LOAD BEARING SHIMS SHALL BE CONSTRUCTED OF HIGH DENSITY PLASTIC OR BETTER. WOOD SHIMS ARE NOT ALLOWED.
3. ANCHOR TYPE, SIZE, SPACING AND EMBEDMENT SHALL BE AS SPECIFIED IN THESE DRAWINGS, SEE TABLE 1, SHEET 6.
4. ALL INSTALLATION ANCHORS MUST BE MADE OF OR PROTECTED WITH A CORROSION RESISTANT MATERIAL OR COATING. DISSIMILAR METALS OR MATERIALS IN CONTACT WITH PRESSURE TREATED WOOD MUST BE PROTECTED TO PREVENT REACTION.
5. INSTALLATION ANCHORS SHALL BE IN ACCORDANCE WITH ANCHOR MANUFACTURER'S INSTALLATION INSTRUCTIONS, AND ANCHORS SHALL NOT BE USED IN SUBSTRATES WITH STRENGTHS LESS THAN THE MINIMUM SPECIFIED IN TABLE 1, SHEET 6.
6. ANCHOR EMBEDMENT TO SUBSTRATE SHALL BE BEYOND WALL DRESSING OR STUCCO. FOR CONCRETE/CMU OPENINGS, EMBEDMENT SHALL BE BEYOND WOOD BUCKS, IF USED, INTO SUBSTRATE. INSTALLATIONS TO SOLID CONCRETE OR GROUT-FILLED CMU MAY INCLUDE BUT DO NOT REQUIRE 1X WOOD BUCKS BETWEEN THE PRODUCT AND THE SUBSTRATE. INSTALLATIONS TO HOLLOW CMU REQUIRE THE USE OF 1X BUCKS BETWEEN THE PRODUCT AND SUBSTRATE.
7. A MINIMUM CENTER-TO-CENTER SPACING SHALL BE MAINTAINED BETWEEN ALL FASTENERS: 3" FOR MASONRY, 1" FOR WOOD AND METAL.
8. WOOD OR MASONRY OPENINGS, BUCKS AND BUCK FASTENERS SHALL BE PROPERLY DESIGNED BY THE ARCHITECT OR ENGINEER OF RECORD AND INSTALLED TO TRANSFER WIND LOADS TO THE STRUCTURE. SUBSTRATES SHALL MEET THE MINIMUM STRENGTH REQUIREMENTS AS SHOWN IN TABLE 1, SHEET 6. CONCRETE AND MASONRY SUBSTRATES MAY NOT BE CRACKED.
9. SEALING AND FLASHING STRATEGIES FOR OVERALL WATER RESISTANCE OF INSTALLATION SHALL BE DONE BY OTHERS FOLLOWING THE CURRENT VERSION OF THE REFERENCE DOCUMENTS: FMA/AAMA 100(FIN WINDOWS), FMA/AAMA 200(FLANGE WINDOWS), FMA/WDMA 250(BOX WINDOWS), FMA/AAMA/WDMA 300(EXTERIOR DOORS)



1900 SW 44TH AVE.
OCALA, FLORIDA 34474
WWW.CWS.CC

8100 PVC SINGLE HUNG IMPACT

PROPRIETARY AND CONFIDENTIAL
THE INFORMATION CONTAINED IN THIS DRAWING IS THE SOLE PROPERTY OF CUSTOM WINDOW SYSTEMS, INC. ANY REPRODUCTION IN PART OR AS A WHOLE WITHOUT THE WRITTEN PERMISSION OF CUSTOM WINDOW SYSTEMS, INC IS PROHIBITED.

FLORIDA APPROVAL NO.:
5823



9/13/2023

LUCAS A. TURNER, P.E.
FL PE # 58201
Turner Engineering & Consulting, Inc.
2428 Old Natchez Trc Trl
Camden, TN 38320
PH. 941-380-1574

SHEET DESCRIPTION:

INSTALLATION DETAILS

DRAWN BY: MCS	DATE: 8/24/2023
DWG #: CWS-491	REV.: F
SCALE: 1:2	SHEET 6 OF 6

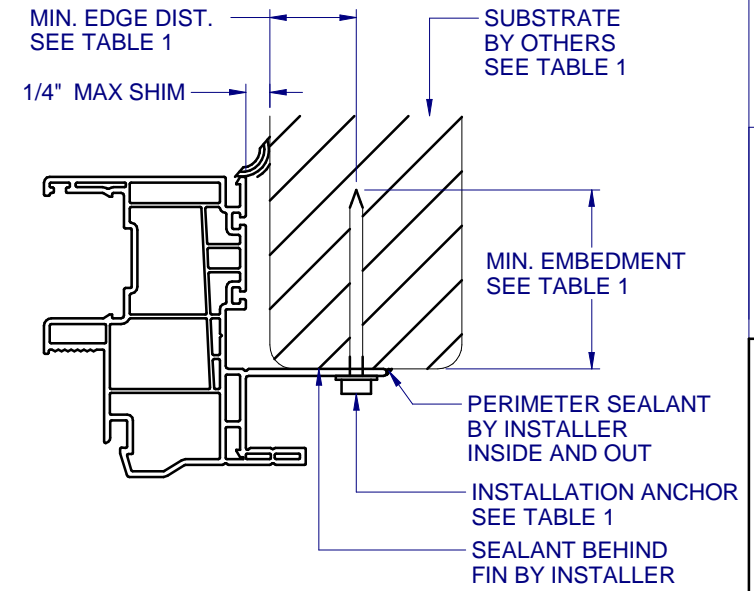
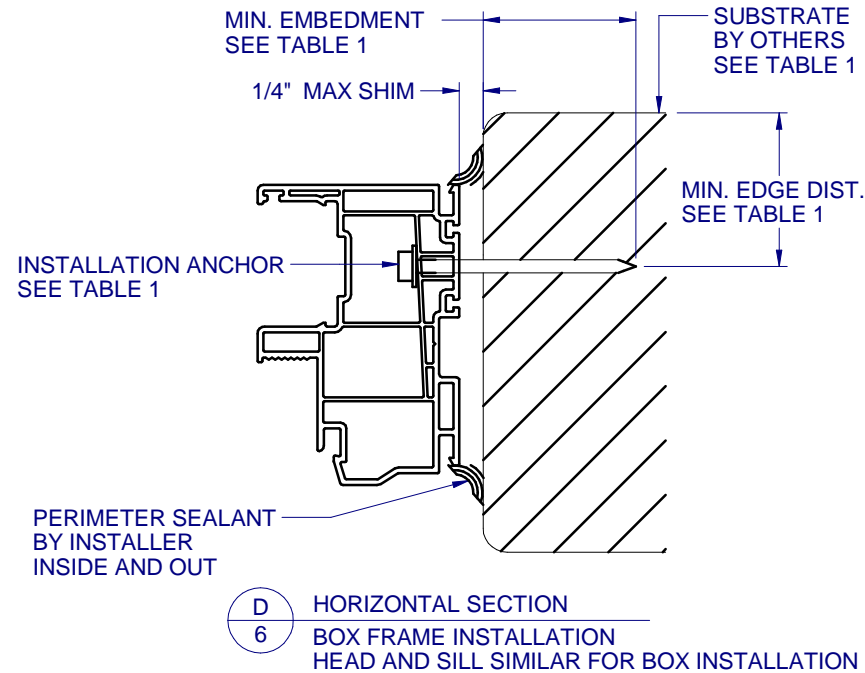
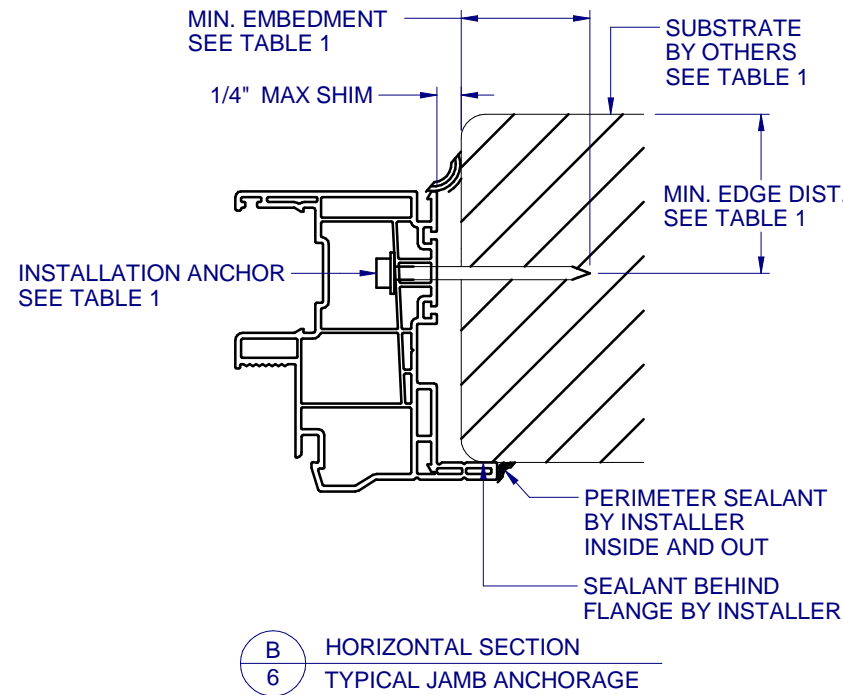
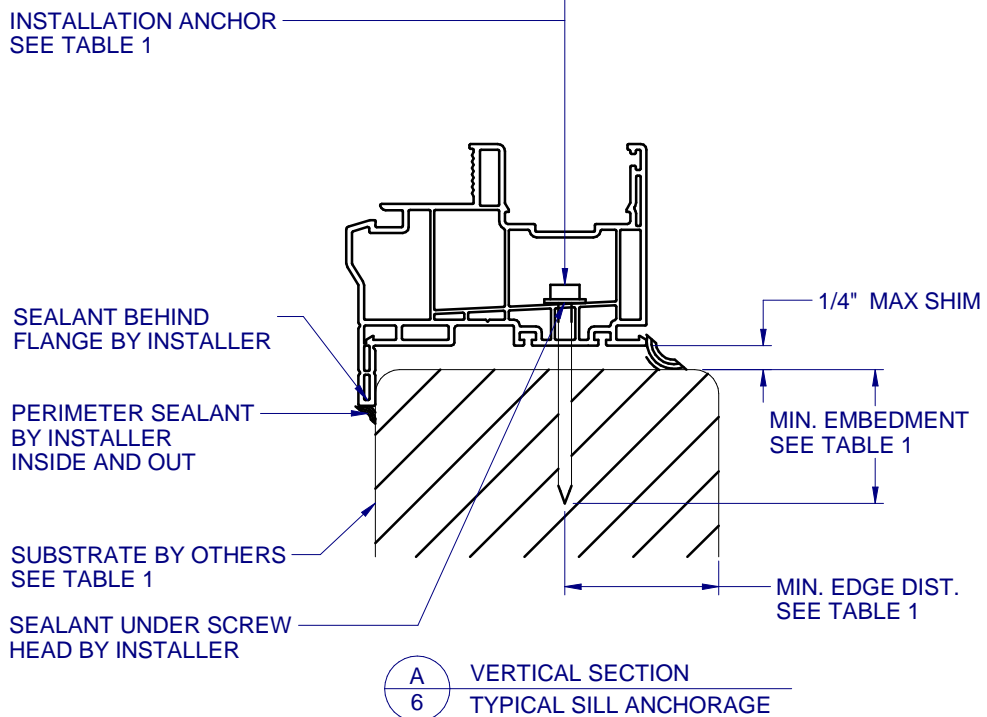
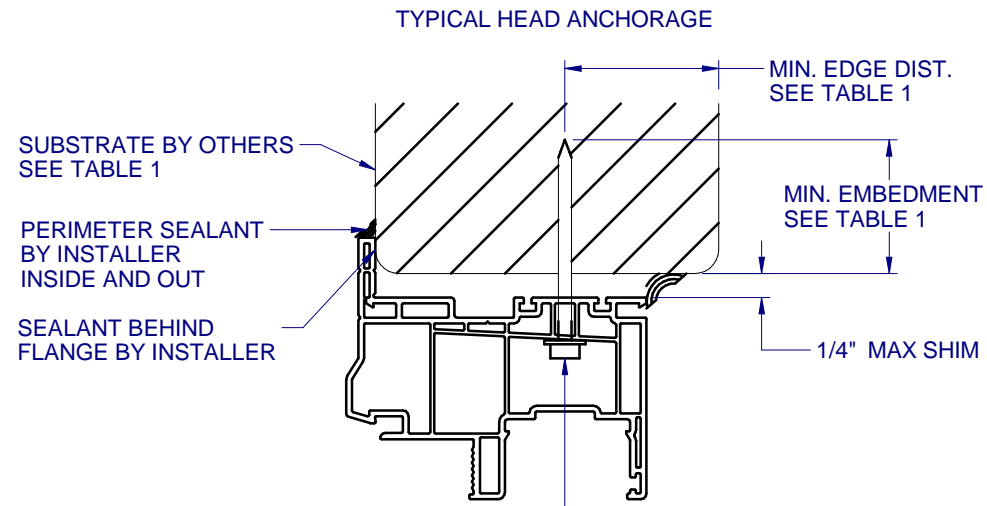

C HORIZONTAL SECTION
6 TYPICAL FIN ANCHORAGE
HEAD AND SILL SIMILAR FOR FIN INSTALLATION

NOTE: ADDITIONAL THRU-FRAME ANCHORS (AS SHOWN IN DET. B/6) REQ'D AT THE MULL, SEE SHEET 5 ANCHOR LAYOUT.

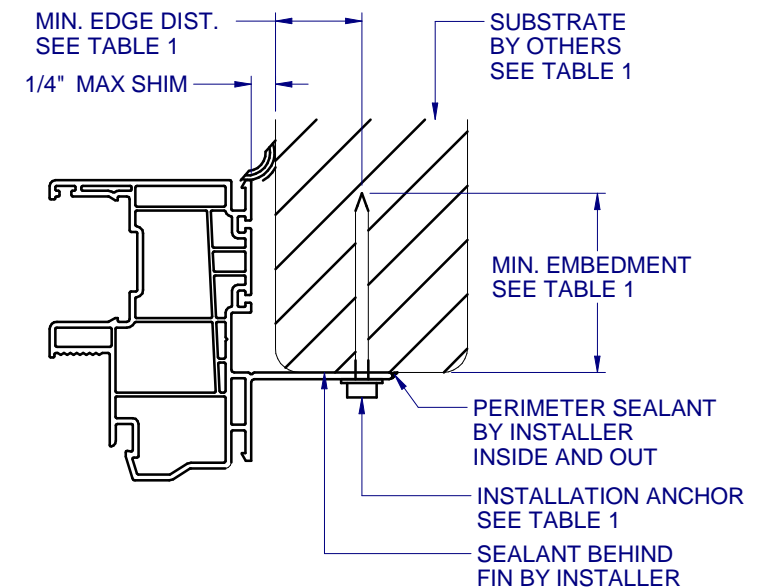

E HORIZONTAL SECTION
6 TYPICAL FIN ANCHORAGE
HEAD AND SILL SIMILAR FOR FIN INSTALLATION

FLANGE REMOVAL NOTE: PARTIALLY OR FULLY REMOVING THE FLANGE, UP TO AND INCLUDING A BOX-FRAME APPLICATION IS ACCEPTABLE PROVIDED:

- MIN. 1/4" FILLET OF CONSTRUCTION-GRADE ADHESIVE CAULK IS APPLIED INSIDE AND OUT, FULL PERIMETER, BY INSTALLER.
- PRODUCT ANCHORAGE IS IN ACCORDANCE WITH REQUIREMENTS AS SHOWN FOR FLANGE WINDOWS.

TABLE 1: APPROVED INSTALLATION FASTENERS

FRAME TYPE	SUBSTRATE TYPE	ANCHOR TYPE	MIN. EMBEDMENT	MIN. EDGE DIST.
FLANGE	CONCRETE (2.0 KSI MIN.)	3/16" ITW TAPCON	1"	1-1/8"
FLANGE	HOLLOW OR GROUT-FILLED CMU (117 PCF MIN.)	3/16" ITW TAPCON	1"	2"
FLANGE	CONCRETE (3.05 KSI MIN.)	3/16" DEWALT ULTRACON+	1-3/4"	1"
FLANGE	HOLLOW OR GROUT-FILLED CMU (ASTM C-90)	3/16" DEWALT ULTRACON+	1-1/4"	2-1/2"
FLANGE	2X MIN. SPRUCE-PINE-FIR (G=0.42)	3/16" ITW TAPCON OR DEWALT ULTRACON+	1-3/8"	7/8"
FLANGE	2X MIN. SPRUCE-PINE-FIR (G=0.42)	#10 WOOD SCREW	1-3/8"	7/8"
FLANGE	16 GAUGE (0.060") MIN. STEEL STUD (33 KSI YIELD MIN)	#10-16 HILTI KWIK-FLEX OR ITW TEKS SELF-DRILLING SCREW	FULL THREAD THRU 0.060"	7/16"
FLANGE	1/8" ALUM. (6063-T5 MIN.) OR 1/8" STEEL (33 KSI MIN.)	#10 GRADE 5 SELF-TAPPING / DRILLING SCREW	FULL THREAD THRU 0.125"	7/16"
FIN	2X MIN. SPRUCE-PINE-FIR (G=0.42)	#8 WOOD SCREW	1-1/2"	7/16"