

# CASEMENT - LARGE MISSILE IMPACT

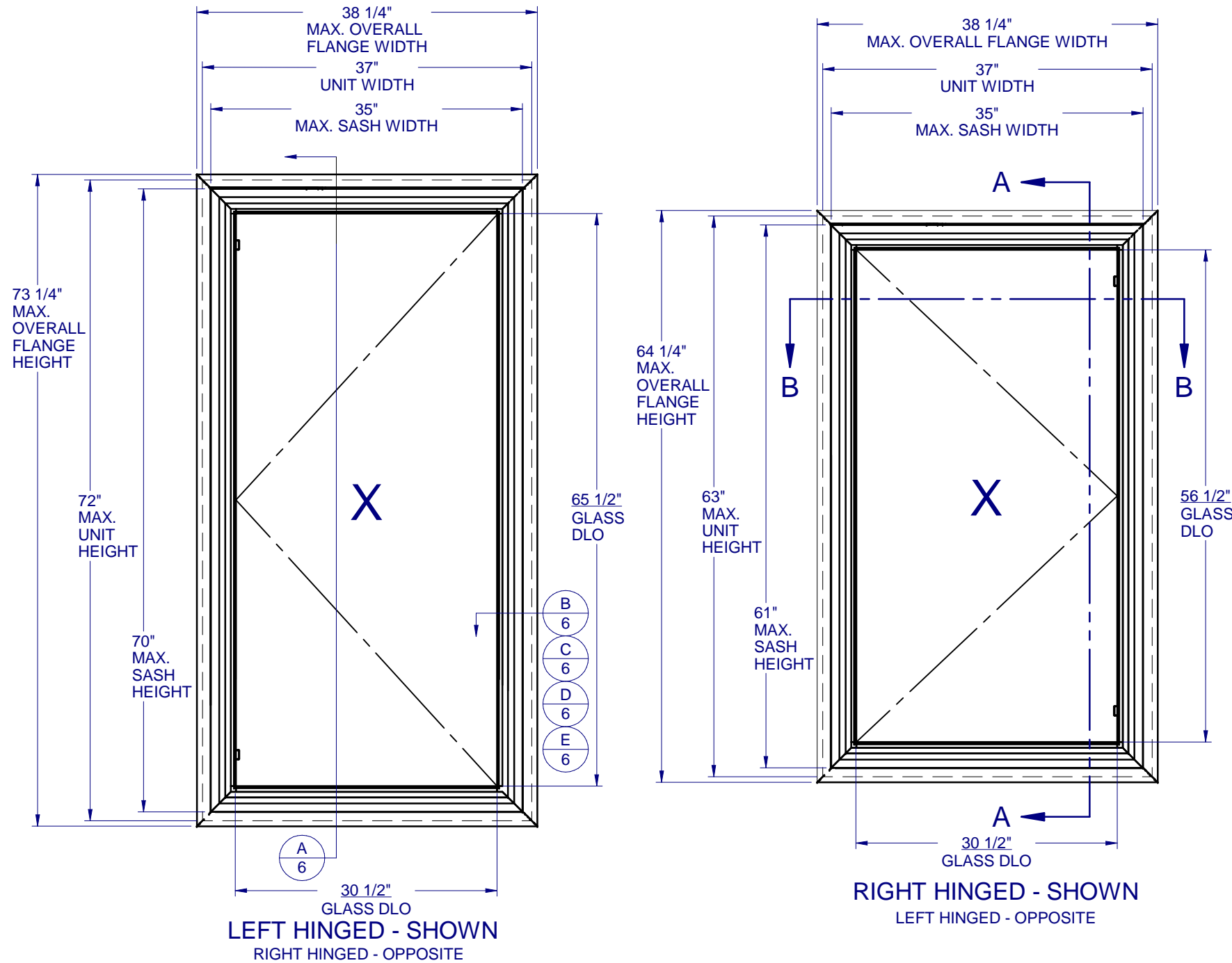

## GENERAL NOTES:

1. THE PRODUCT SHOWN HEREIN IS DESIGNED AND MANUFACTURED TO COMPLY WITH THE FLORIDA BUILDING CODE (FBC), CURRENT EDITION INCLUDING THE HIGH VELOCITY HURRICANE ZONE (HVHZ) AND IS RATED FOR WIND ZONE 4 MISSILE LEVEL D IMPACT USE AS DEFINED IN ASTM E 1996 PER THE FBC.
2. GLAZING OPTIONS: (SEE SHEET 2)
3. CONFIGURATIONS: ALL WINDOWS ARE OPEN TO OUTSIDE LEFT OR RIGHT.
4. DESIGN PRESSURES:  
 -NEGATIVE DESIGN LOADS BASED ON TESTED PRESSURE AND GLASS TABLES ASTM E-1300-04e01/09.  
 -POSITIVE DESIGN LOADS BASED ON TESTED PRESSURE, WATER INFILTRATION TEST PRESSURE, AND GLASS TABLES ASTM E-1300-04e01/09.
5. ANCHORAGE: THE 33 1/3% STRESS INCREASE HAS NOT BEEN USED IN THE DESIGN OF THIS PRODUCT. SEE SHEET 6 FOR INSTALLATION DETAIL. WIND LOAD DURATION FACTOR Cd=1.6 WAS USED FOR WOOD ANCHOR CALCULATIONS.
6. PRODUCTS APPROVED FOR IMPACT RESISTANCE. SHUTTERS ARE NOT REQUIRED.
7. ALL FRAMES AND VENTS FULLY WELDED.
8. SERIES/MODEL DESIGNATION CA-8400.
9. THE DESIGNATION X STANDS FOR THE FOLLOWING:  
 X = OPERABLE SASH
10. SECTION CALLOUTS APPLY TO ALL ELEVATIONS IN A SIMILAR LOCATION.



## 8400 PVC CASEMENT IMPACT

PROPRIETARY AND CONFIDENTIAL  
 THE INFORMATION CONTAINED IN THIS DRAWING IS THE SOLE PROPERTY OF CUSTOM WINDOW SYSTEMS, INC. ANY REPRODUCTION IN PART OR AS A WHOLE WITHOUT THE WRITTEN PERMISSION OF CUSTOM WINDOW SYSTEMS, INC IS PROHIBITED.

FLORIDA APPROVAL NO.:  
 6890



8/15/2023

LUCAS A. TURNER, P.E.  
 FL PE # 58201  
 Turner Engineering & Consulting, Inc.  
 2428 Old Natchez Trc Trl  
 Camden, TN 38320  
 PH. 941-380-1574

SHEET DESCRIPTION:

## GENERAL NOTES AND ELEVATIONS

DRAWN BY: MCS	DATE: 8/9/2023
DWG #: CWS-161	REV.: F
SCALE: 1:15	SHEET 1 OF 6

## TABLE OF CONTENTS

- GENERAL NOTES & ELEVATIONS.....1
- GLAZING DETAILS.....2
- SECTION VIEWS.....3
- BOM & EXTRUSIONS.....4
- ANCHOR SCHEDULE & NOTES.....5
- INSTALLATION DETAILS.....6

LOCATION	MAX. UNIT SIZE	DESIGN PRESSURE RATING	IMPACT RATING
NON-HVHZ	37" x 63"	+/- 65 PSF	LARGE MISSILE IMPACT
HVHZ		+/- 67.5 PSF	
NON-HVHZ	37" x 72"	+/- 65 PSF	
HVHZ		+/- 67.5 PSF	



1900 SW 44TH AVE.  
OCALA, FLORIDA 34474  
WWW.CWS.CC

**8400 PVC  
CASEMENT  
IMPACT**

PROPRIETARY AND CONFIDENTIAL  
THE INFORMATION CONTAINED IN  
THIS DRAWING IS THE SOLE  
PROPERTY OF CUSTOM WINDOW  
SYSTEMS, INC. ANY  
REPRODUCTION IN PART OR AS A  
WHOLE WITHOUT THE WRITTEN  
PERMISSION OF CUSTOM WINDOW  
SYSTEMS, INC IS PROHIBITED.

FLORIDA APPROVAL NO.:

6890

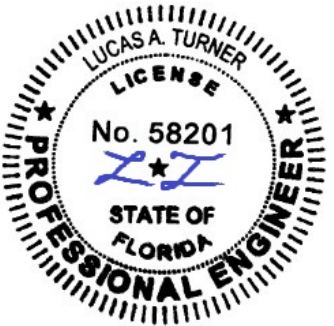

8/15/2023

LUCAS A. TURNER, P.E.  
FL PE # 58201  
Turner Engineering &  
Consulting, Inc.  
2428 Old Natchez Trc Trl  
Camden, TN 38320  
PH. 941-380-1574

SHEET DESCRIPTION:

**GLAZING DETAILS**

DRAWN BY: MCS	DATE: 8/9/2023
DWG #: CWS-161	REV.: F
SCALE: 1:1	SHEET 2 OF 6

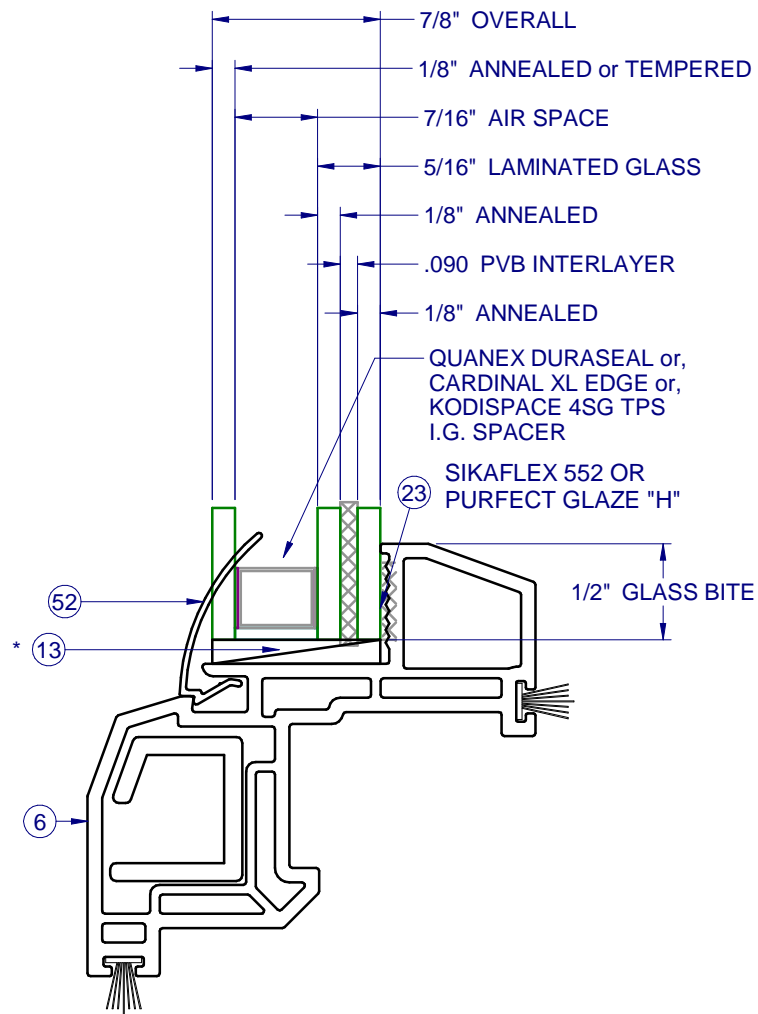

GLASS TYPE A

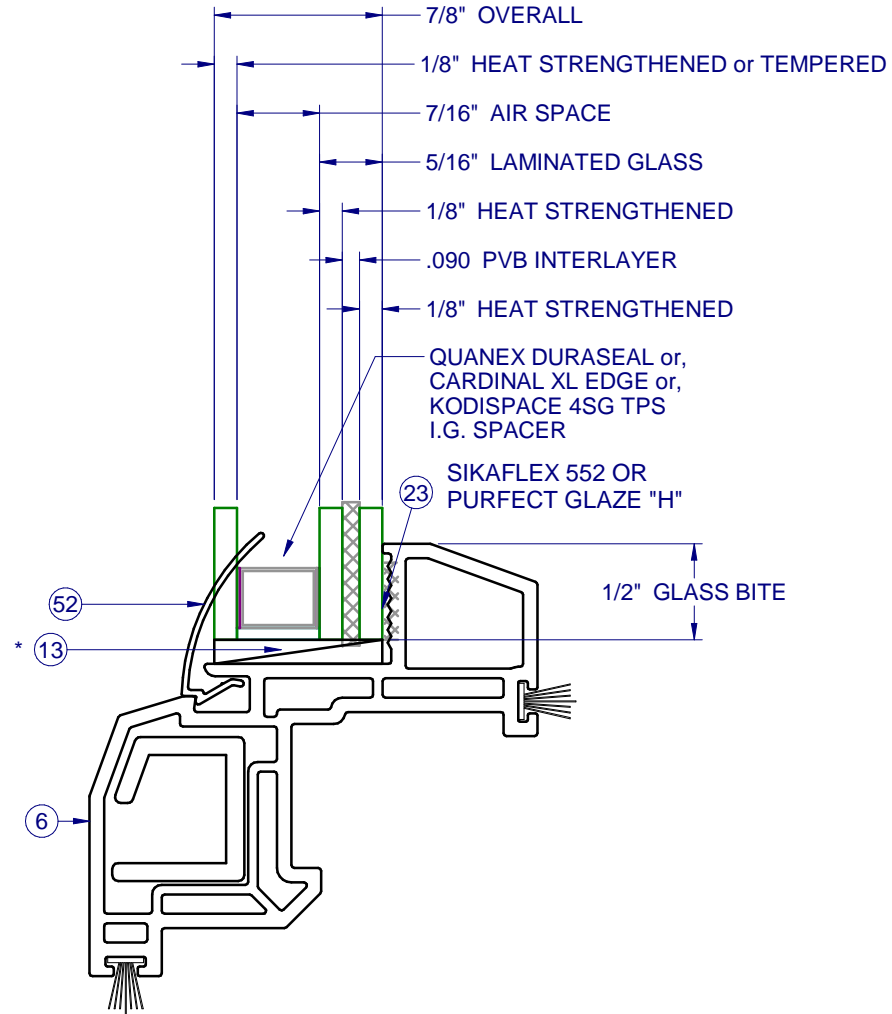

GLASS TYPE B

\* SETTING BLOCKS PER FBC 2411.3.3.1

MAX. UNIT SIZE	MAX. POS. DP	GLASS TYPE
37" x 63"	+67.5	A
37" x 72"	+67.5	B



1900 SW 44TH AVE.  
OCALA, FLORIDA 34474  
WWW.CWS.CC

**8400 PVC  
CASEMENT  
IMPACT**

PROPRIETARY AND CONFIDENTIAL  
THE INFORMATION CONTAINED IN  
THIS DRAWING IS THE SOLE  
PROPERTY OF CUSTOM WINDOW  
SYSTEMS, INC. ANY  
REPRODUCTION IN PART OR AS A  
WHOLE WITHOUT THE WRITTEN  
PERMISSION OF CUSTOM WINDOW  
SYSTEMS, INC IS PROHIBITED.

FLORIDA APPROVAL NO.:

6890

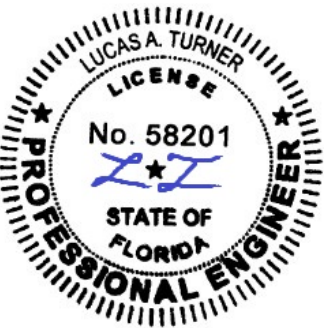

8/15/2023

LUCAS A. TURNER, P.E.  
FL PE # 58201  
Turner Engineering &  
Consulting, Inc.  
2428 Old Natchez Trc Trl  
Camden, TN 38320  
PH. 941-380-1574

SHEET DESCRIPTION:

**SECTION VIEWS**

DRAWN BY:	DATE:
MCS	8/9/2023
DWG #:	REV.:
CWS-161	F
SCALE:	SHEET
1:2	3 OF 6

INTERIOR

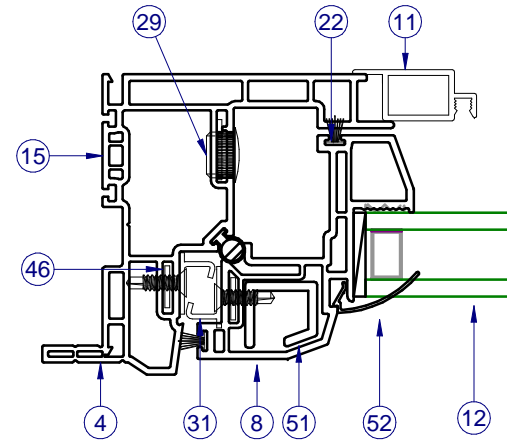

SECTION VIEW B-B

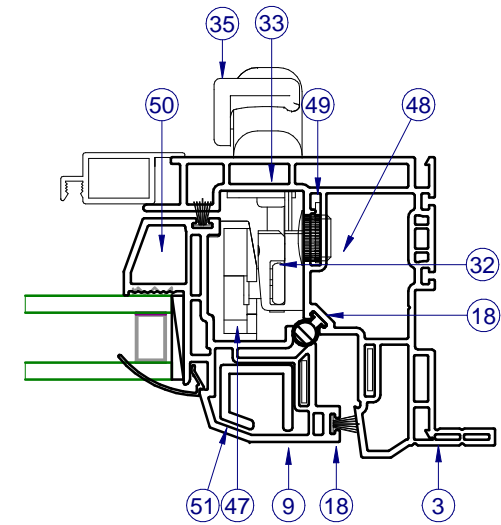

INTERIOR

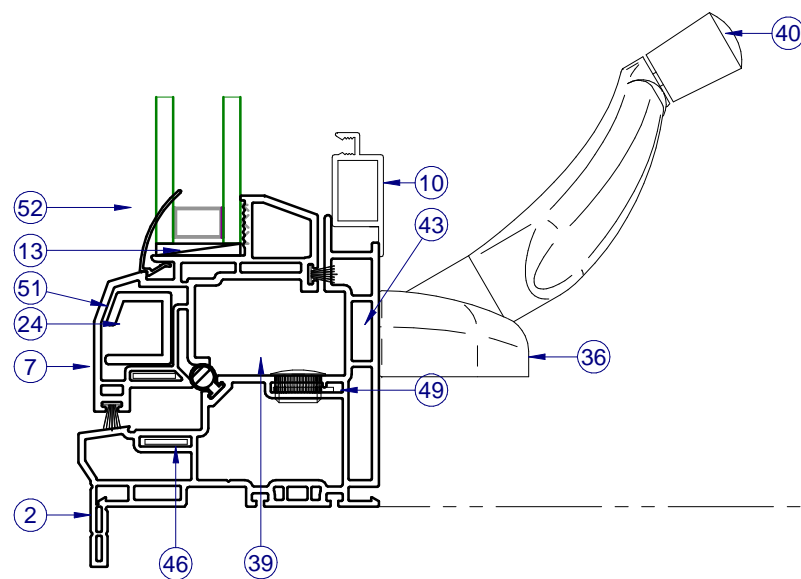

SECTION VIEW A-A

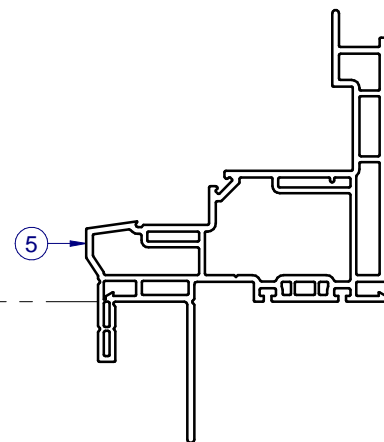

ALTERNATE FIN FRAME

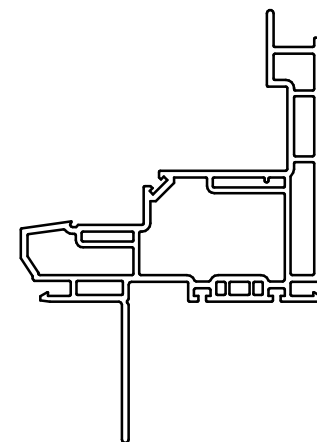

ALTERNATE FIN ONLY FRAME

ITEMS NOT SHOWN FOR CLARITY:  
14, 16-17, 19-20, 25, 27, 32, 34, 37-38, 42, 44-45, 50

PARTS LIST			
ITEM	PART #	DESCRIPTION	MATERIAL
1	H-6235	FR., CASE., MAIN, HEAD	PVC
2	H-6235	FR., CASE., MAIN, SILL	PVC
3	H-6235	FR., CASE., MAIN, JB., RIGHT	PVC
4	H-6235	FR., CASE., MAIN, JB., LEFT	PVC
5	H-6235	FR., CASE., W/ FIN	PVC
6	H-6234	SASH, CASE., TOP RAIL	PVC
7	H-6234	SASH, CASE., BOT. RAIL	PVC
8	H-6234	SASH, CASE., SIDE RAIL, HINGE	PVC
9	H-6234	SASH, CASE., SIDE RAIL, LOCK	PVC
10	H-1592	SCREEN RAIL, SIDE/BTM	ALUM
11	H-1593	SCREEN RAIL, TOP/SIDE	ALUM
12	GLASS	SEE SHEET 2	
13	P-5612	Setting Block, .12 x 1 x 2	RUBBER
14	P-4755	Screen Corner Key W/ Safety Pull Tab	
16	P-3195	SCREEN SPRING, NO HOLE TENSION	
17	P-3197	SCREEN CORNER KEY	NYLON
18	P-5573	WSTP., BULB, HOLLOW, T-SLOT, .187 X .358	RUBBER
19	P-3228	SCREEN SPLINE, .155 DIA, BLK	
20		SPACER, SEE SHEET 3	
21	P-3342	SEAM SEALER, SM-5504	SILICONE
22	P-3305	WSTP., .270 X .187 High Density	
23		PURFECT GLAZE "H", SIKAFLEX 552	
24	P-3539	#8 X 3/4" QUAD PH TEK, ZINC, SCREW	
25	P-3565	36" - 18x14 CHARCOAL SCREEN	
26	P-3587	#8 X 1" PH FH TEK 2, SS, SCREW	SS
29	P-5588	CAP PLUG, 1/2" HOLE	NYLON
31	P-3940	SNUBBER, SS, PVC	
32	P-4003	TIE BAR GUIDE, ROTO. HDWE.	SS
33	P-4004	#8-32 X 1/2" PH PH, MS, SS (ROTO HDWE. LOCK)	SS
34	P-4005	SUPPORT PLATE, LOCK, SS, ROTO HDWE. (Use w/ P-4006)	SS
35	P-4006	LOCK, MULTI-POINT, ROTO HDWE., WHITE	SS
36	P-4501	OPERATOR, DUAL ARM, LH (ROTO X-Drive SS)	SS
37	P-4009	TRACK & SLIDER ASSM., ROTO OPER., ROTO HDWE., (13")	SS
38	P-4010	STUD BRKT., ROTO OPER., L.H., ROTO HDWE.	SS
39	P-4012	SHIM, ROTO OPERATOR, ROTO HDWE. (4.8mm)	NYLON
40	P-4503	HANDLE, FOLDING, ROTO OPER., ROTO HDWE. (X-Drive SS)	ZINC
41	P-4018	HINGE TRACK, 13 INCH (ROTO HDWE)	SS
42	P-4020	SUPPORT WASHER, ROTO OPER., ROTO HDWE., 1/16"	SS
43	P-4521	#8-32 x 3/4" Trilobe Truss Head	SS
44	P-4024	GASKET, ROTO OPER., ROTO HDWE., 1/16"	
45	P-4031-P-4040	TIE-BARS, ROTO HDWE. 1-5 LOCKPOINTS, SS (BY OA HGT.)	SS
46	P-4050	REINF. COIL-ALUMINUM, 5052-H32 (.050 X .437), HD	ALUM
47	P-4043	STRIKE, MULTIPOINT	NYLON
48	P-4146	#8 x 3/4" PH FLAT TEK, SS	SS
49	P-4491	REINF. COIL-ALUMINUM, 5052-H32 (.062 X .656), HD	ALUM
50	P-4641	#8 x 5/8" PH FLAT TEK, #7 HEAD, SS	SS
51	S-1505	REINF. CASE. SASH	ALUM
52	S-6237	GLZ. BD., 7/8"	PVC

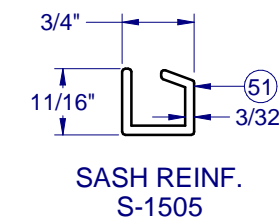
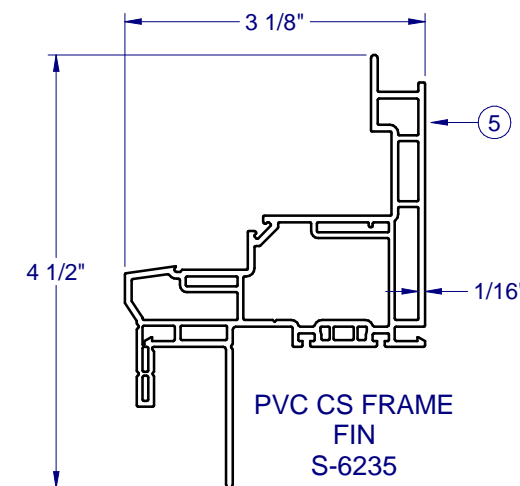
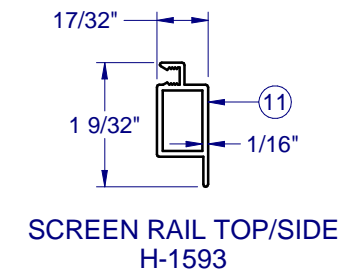
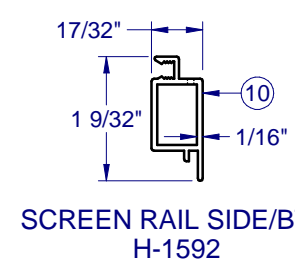
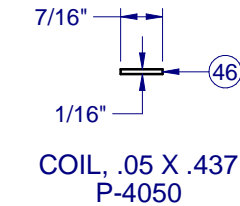
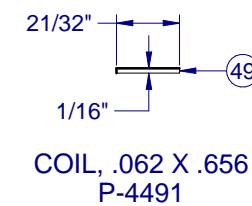
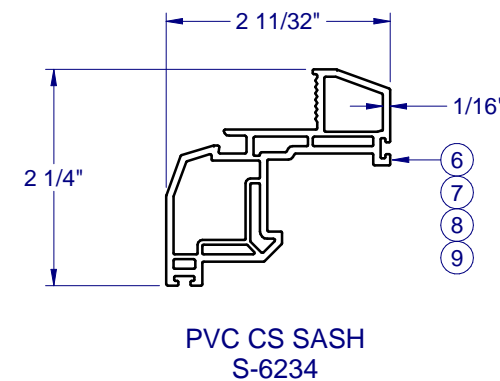
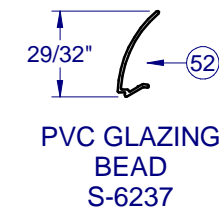
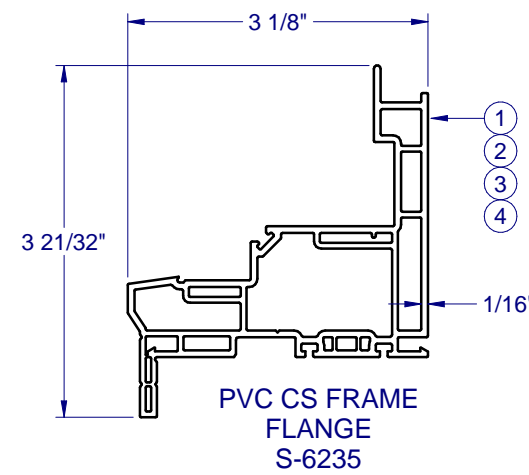

**FRAME AND SASH CORNER CONSTRUCTION**

CORNER WELD (ALL SIDES) 1:8

1900 SW 44TH AVE.  
OCALA, FLORIDA 34474  
WWW.CWS.CC

**8400 PVC CASEMENT IMPACT**

PROPRIETARY AND CONFIDENTIAL

THE INFORMATION CONTAINED IN THIS DRAWING IS THE SOLE PROPERTY OF CUSTOM WINDOW SYSTEMS, INC. ANY REPRODUCTION IN PART OR AS A WHOLE WITHOUT THE WRITTEN PERMISSION OF CUSTOM WINDOW SYSTEMS, INC IS PROHIBITED.

FLORIDA APPROVAL NO.: 6890

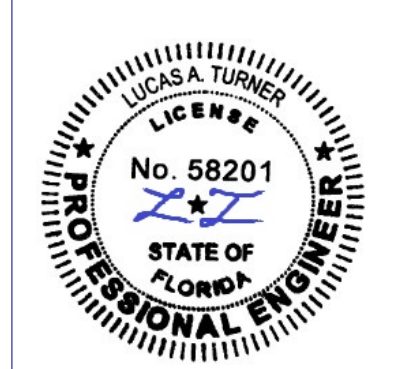

8/15/2023

LUCAS A. TURNER, P.E.  
FL PE # 58201  
Turner Engineering & Consulting, Inc.  
2428 Old Natchez Trc Trl  
Camden, TN 38320  
PH. 941-380-1574

SHEET DESCRIPTION:  
**BOM AND EXTRUSIONS**

DRAWN BY: <b>MCS</b>	DATE: <b>8/9/2023</b>
DWG #: <b>CWS-161</b>	REV.: <b>F</b>
SCALE: <b>1:2</b>	SHEET <b>4 OF 6</b>

NOTE: ALL ALUMINUM EXTRUSIONS ARE 6063-T6 UNLESS OTHERWISE NOTED.



## 8400 PVC CASEMENT IMPACT

PROPRIETARY AND CONFIDENTIAL  
THE INFORMATION CONTAINED IN  
THIS DRAWING IS THE SOLE  
PROPERTY OF CUSTOM WINDOW  
SYSTEMS, INC. ANY  
REPRODUCTION IN PART OR AS A  
WHOLE WITHOUT THE WRITTEN  
PERMISSION OF CUSTOM WINDOW  
SYSTEMS, INC IS PROHIBITED.

FLORIDA APPROVAL NO.:

6890

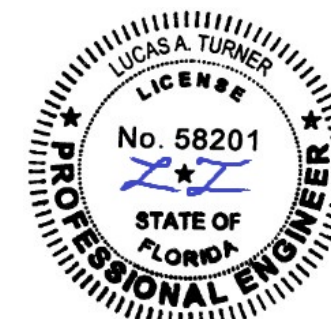

8/15/2023

LUCAS A. TURNER, P.E.  
FL PE # 58201  
Turner Engineering &  
Consulting, Inc.  
2428 Old Natchez Trc Trl  
Camden, TN 38320  
PH. 941-380-1574

SHEET DESCRIPTION:

ANCHOR SCHEDULE &  
NOTES

DRAWN BY:	DATE:
MCS	8/9/2023
DWG #:	REV.:
CWS-161	F
SCALE:	SHEET
1:20	5 OF 6

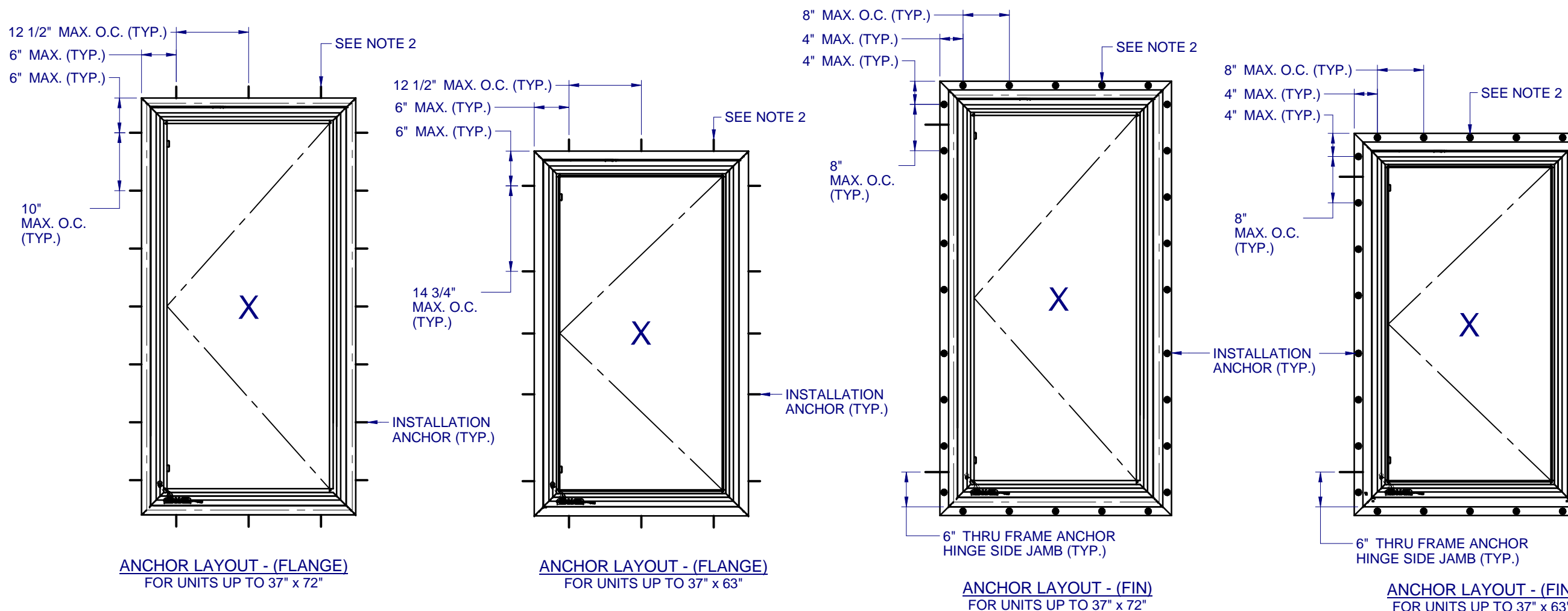

### NOTES:

1. INSTALL ONE ANCHOR AT EACH INSTALLATION LOCATION. SILL ANCHOR SPACING SAME AS HEAD.
2. SHIM AS REQ AT EACH INSTALLATION ANCHOR USING LOAD BEARING SHIMS. MAX. ALLOWABLE SHIM STACK TO BE 1/4". USE SHIMS WHERE SPACE GREATER THAN 1/16" IS PRESENT. LOAD BEARING SHIMS SHALL BE CONSTRUCTED OF HIGH DENSITY PLASTIC OR BETTER. WOOD SHIMS ARE NOT ALLOWED.
3. ANCHOR TYPE, SIZE, SPACING AND EMBEDMENT SHALL BE AS SPECIFIED IN THESE DRAWINGS, SEE TABLE 1, SHEET 6.
4. ALL INSTALLATION ANCHORS MUST BE MADE OF OR PROTECTED WITH A CORROSION RESISTANT MATERIAL OR COATING. DISSIMILAR METALS OR MATERIALS IN CONTACT WITH PRESSURE TREATED WOOD MUST BE PROTECTED TO PREVENT REACTION.
5. INSTALLATION ANCHORS SHALL BE IN ACCORDANCE WITH ANCHOR MANUFACTURER'S INSTALLATION INSTRUCTIONS, AND ANCHORS SHALL NOT BE USED IN SUBSTRATES WITH STRENGTHS LESS THAN THE MINIMUM SPECIFIED IN TABLE 1, SHEET 6.
6. ANCHOR EMBEDMENT TO SUBSTRATE SHALL BE BEYOND WALL DRESSING OR STUCCO. FOR CONCRETE/CMU OPENINGS, EMBEDMENT SHALL BE BEYOND WOOD BUCKS, IF USED, INTO SUBSTRATE. INSTALLATIONS TO SOLID CONCRETE OR GROUT-FILLED CMU MAY INCLUDE BUT DO NOT REQUIRE 1X WOOD BUCKS BETWEEN THE PRODUCT AND THE SUBSTRATE. INSTALLATIONS TO HOLLOW CMU REQUIRE THE USE OF 1X BUCKS BETWEEN THE PRODUCT AND SUBSTRATE.
7. A MINIMUM CENTER-TO-CENTER SPACING SHALL BE MAINTAINED BETWEEN ALL FASTENERS: 3" FOR MASONRY, 1" FOR WOOD AND METAL.
8. WOOD OR MASONRY OPENINGS, BUCKS AND BUCK FASTENERS SHALL BE PROPERLY DESIGNED BY THE ARCHITECT OR ENGINEER OF RECORD AND INSTALLED TO TRANSFER WIND LOADS TO THE STRUCTURE. SUBSTRATES SHALL MEET THE MINIMUM STRENGTH REQUIREMENTS AS SHOWN IN TABLE 1, SHEET 6. CONCRETE AND MASONRY SUBSTRATES MAY NOT BE CRACKED.
9. SEALING AND FLASHING STRATEGIES FOR OVERALL WATER RESISTANCE OF INSTALLATION SHALL BE DONE BY OTHERS FOLLOWING THE CURRENT VERSION OF THE REFERENCE DOCUMENTS: FMA/AAMA 100(FIN WINDOWS), FMA/AAMA 200(FLANGE WINDOWS), FMA/WDMA 250(BOX WINDOWS), FMA/AAMA/WDMA 300(EXTERIOR DOORS)

### 8400 PVC CASEMENT IMPACT

PROPRIETARY AND CONFIDENTIAL  
THE INFORMATION CONTAINED IN THIS DRAWING IS THE SOLE PROPERTY OF CUSTOM WINDOW SYSTEMS, INC. ANY REPRODUCTION IN PART OR AS A WHOLE WITHOUT THE WRITTEN PERMISSION OF CUSTOM WINDOW SYSTEMS, INC IS PROHIBITED.

FLORIDA APPROVAL NO.:

6890



8/15/2023

LUCAS A. TURNER, P.E.  
FL PE # 58201  
Turner Engineering & Consulting, Inc.  
2428 Old Natchez Trc Trl  
Camden, TN 38320  
PH. 941-380-1574

SHEET DESCRIPTION:

#### INSTALLATION DETAILS

DRAWN BY:	DATE:
MCS	8/9/2023
DWG #:	REV.:
CWS-161	F
SCALE:	SHEET
1:2	6 OF 6

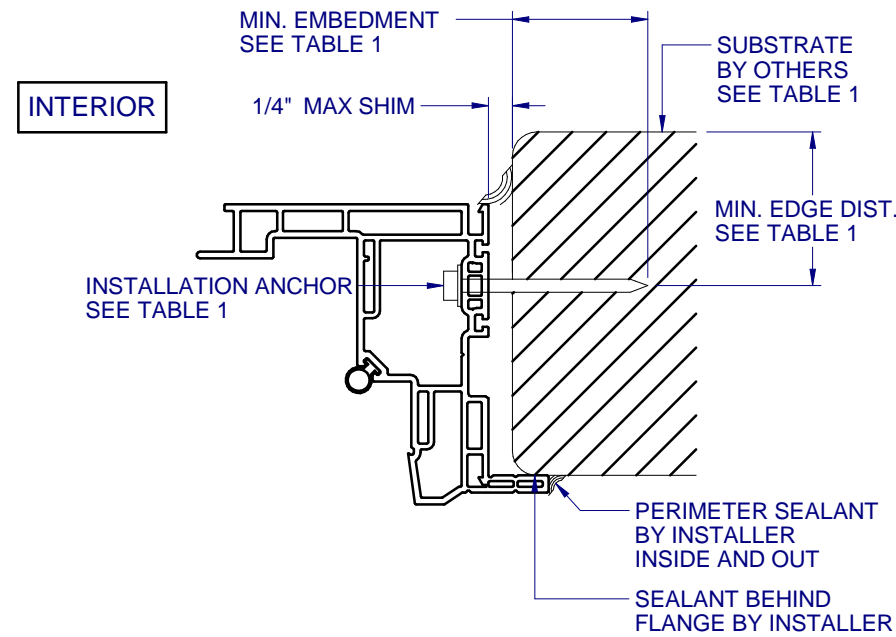
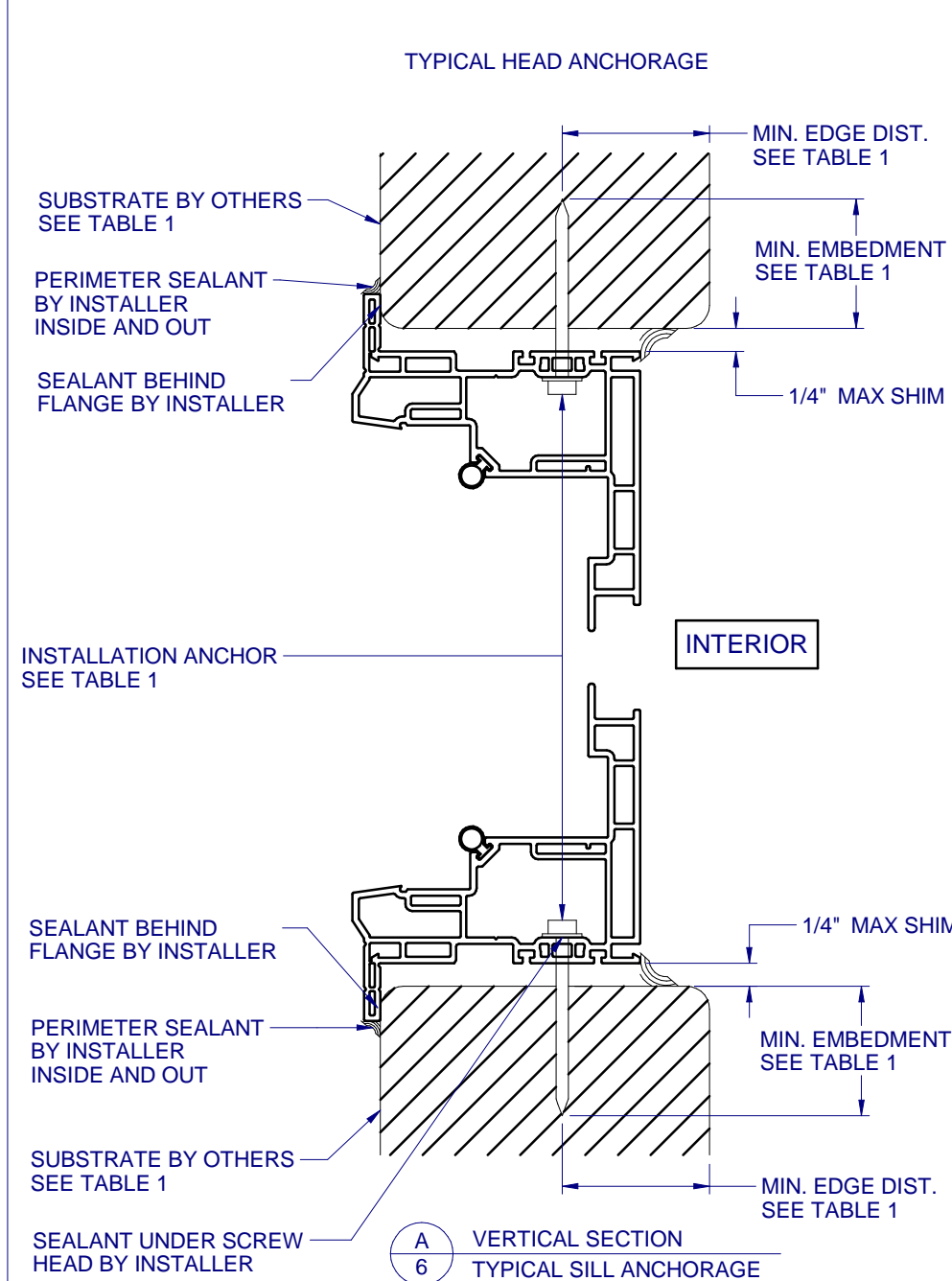

**B** HORIZONTAL SECTION  
6 TYPICAL JAMB ANCHORAGE

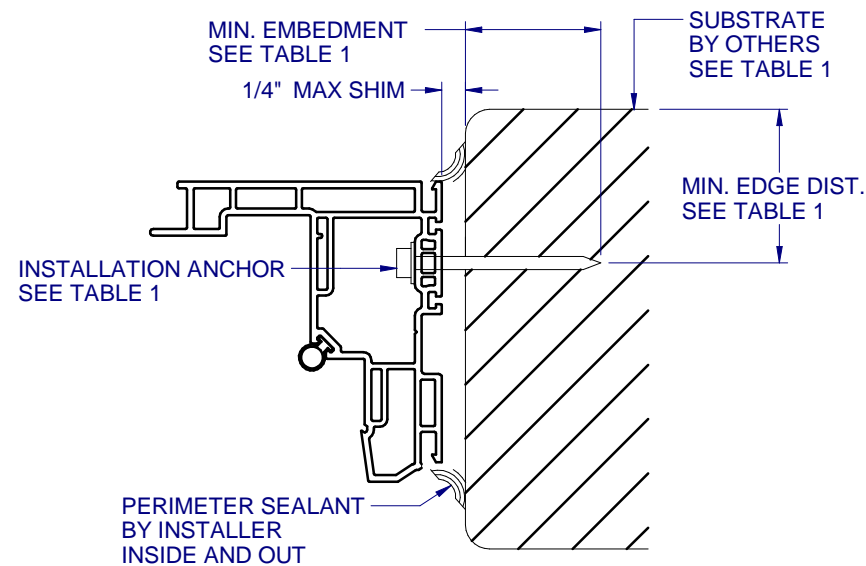

**D** HORIZONTAL SECTION  
6 BOX FRAME INSTALLATION  
HEAD AND SILL SIMILAR FOR BOX INSTALLATION

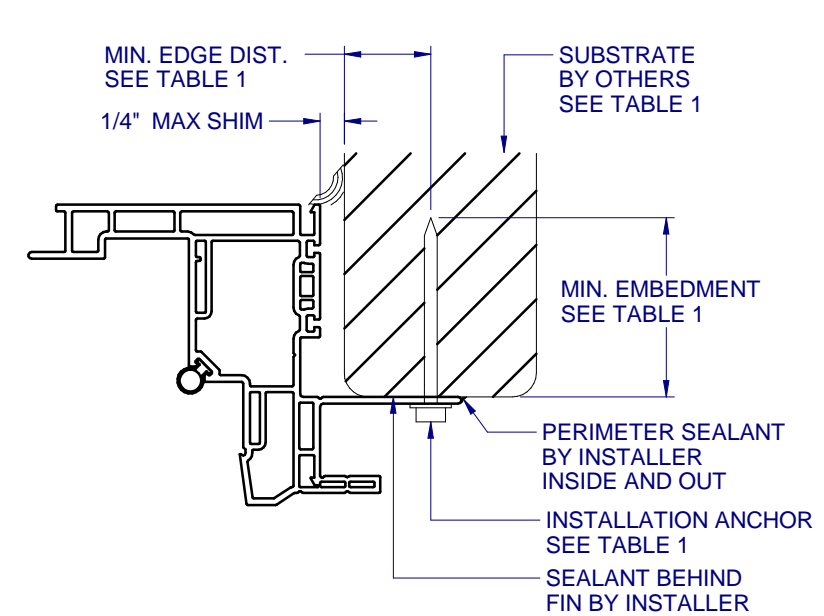

**C** HORIZONTAL SECTION  
6 TYPICAL FIN ANCHORAGE  
HEAD AND SILL SIMILAR FOR FIN INSTALLATION

NOTE: ADDITIONAL THRU-FRAME ANCHORS (AS SHOWN IN DET. B/6) REQ'D AT THE HINGE SIDE JAMB, SEE SHEET 5 ANCHOR LAYOUT.

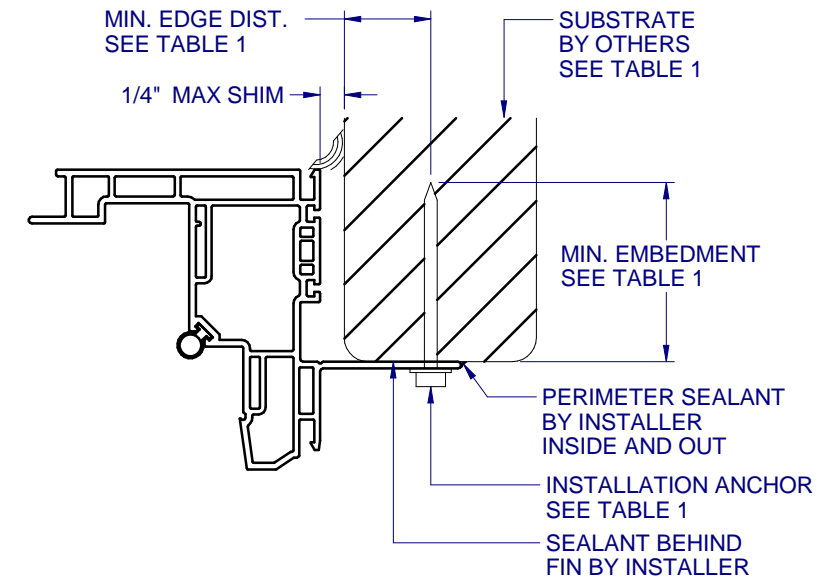

**E** HORIZONTAL SECTION  
6 TYPICAL FIN ANCHORAGE  
HEAD AND SILL SIMILAR FOR FIN INSTALLATION

NOTE: ADDITIONAL THRU-FRAME ANCHORS (AS SHOWN IN DET. B/6) REQ'D AT THE HINGE SIDE JAMB, SEE SHEET 5 ANCHOR LAYOUT.

FLANGE REMOVAL NOTE: PARTIALLY OR FULLY REMOVING THE FLANGE, UP TO AND INCLUDING A BOX-FRAME APPLICATION IS ACCEPTABLE PROVIDED:

- MIN. 1/4" FILLET OF CONSTRUCTION-GRADE ADHESIVE CAULK IS APPLIED INSIDE AND OUT, FULL PERIMETER, BY INSTALLER.
- PRODUCT ANCHORAGE IS IN ACCORDANCE WITH REQUIREMENTS AS SHOWN FOR FLANGE WINDOWS.

**TABLE 1: APPROVED INSTALLATION FASTENERS**

FRAME TYPE	SUBSTRATE TYPE	ANCHOR TYPE	MIN. EMBEDMENT	MIN. EDGE DIST.
FLANGE	CONCRETE (2.0 KSI MIN.)	3/16" ITW TAPCON	1-1/2"	1-1/8"
FLANGE	HOLLOW OR GROUT-FILLED CMU (117 PCF MIN.)	3/16" ITW TAPCON	1"	2"
FLANGE	CONCRETE (3.05 KSI MIN.)	3/16" DEWALT ULTRACON+	1-3/4"	1"
FLANGE	HOLLOW OR GROUT-FILLED CMU (ASTM C-90)	3/16" DEWALT ULTRACON+	1-1/4"	2-1/2"
FLANGE	2X MIN. SOUTHERN PINE (G=0.55)	3/16" ITW TAPCON OR DEWALT ULTRACON+	1-3/8"	7/8"
FLANGE	2X MIN. SOUTHERN PINE (G=0.55)	#10 WOOD SCREW	1-3/8"	7/8"
FLANGE	16 GAUGE (0.060") MIN. STEEL STUD (33 KSI YIELD MIN)	#10-16 HILTI KWIK-FLEX OR ITW TEKS SELF-DRILLING SCREW	FULL THREAD THRU 0.060"	7/16"
FLANGE	1/8" ALUM. (6063-T5 MIN.) OR 1/8" STEEL (33 KSI MIN.)	#10 GRADE 5 SELF-TAPPING / DRILLING SCREW	FULL THREAD THRU 0.125"	7/16"
FIN	2X MIN. SPRUCE-PINE-FIR (G=0.42)	#8 WOOD SCREW	1-1/2"	7/16"