

ELEVATION FOR TYP. EQUAL LEG FRAME,
EQUAL-LITE CONFIGURATION

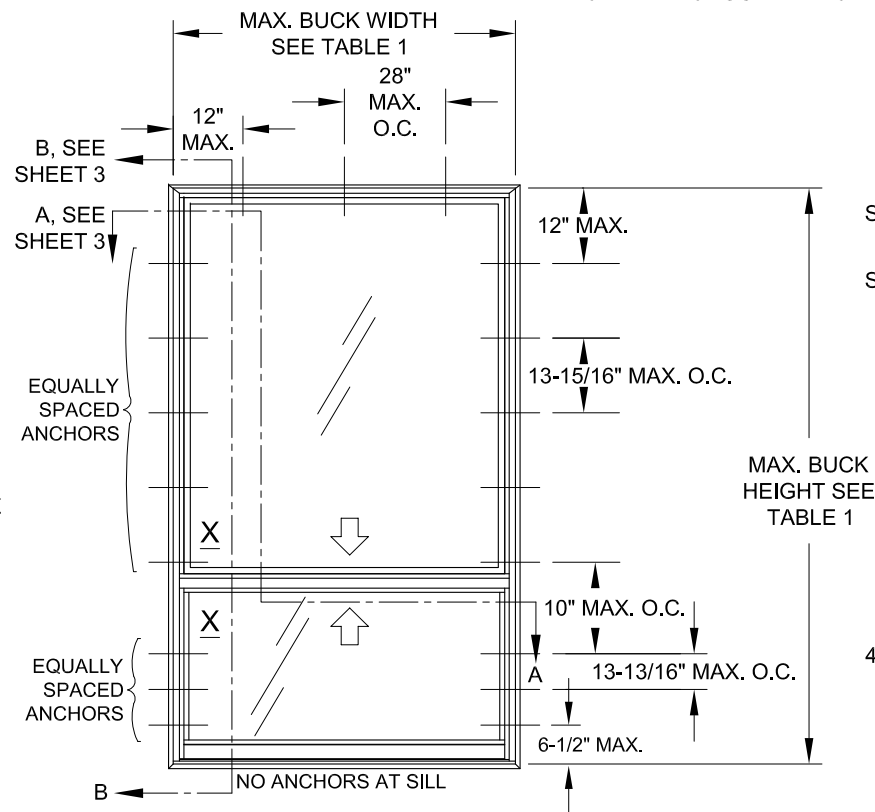

ELEVATION FOR TYP. FLANGE FRAME,
PROVIEW/ORIEL CONFIGURATION
(COTTAGE SIMILAR)

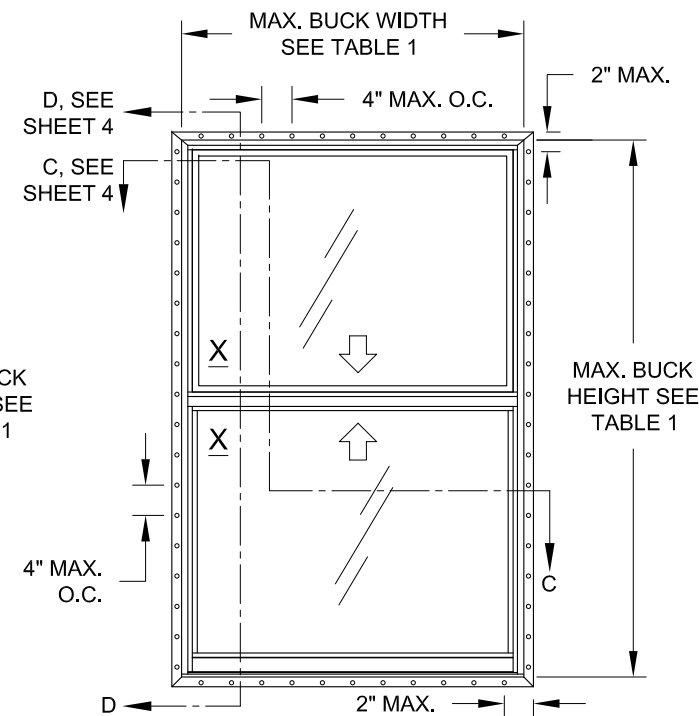

ELEVATION FOR TYP. FIN OR J-CHANNEL FRAME,
EQUAL-LITE CONFIGURATION
(SIMILAR ANCHOR DIMENSIONS FOR OTHER CONFIGURATIONS)

DESIGN PRESSURE RATING
SEE TABLE 1
IMPACT RATING
NOT RATED FOR IMPACT RESISTANCE

Rev. # 08/01/22
Date
Method
UPDATED CERT. METHOD
D

SERIES DH5460V NON-IMPACT RESISTANT, VINYL DOUBLE HUNG WINDOW

- 1) THIS PRODUCT HAS BEEN DESIGNED & TESTED TO COMPLY WITH THE REQUIREMENTS OF THE CURRENT FLORIDA BUILDING CODE.
- 2) SHUTTERS ARE REQUIRED WHEN USED IN WIND-BORNE DEBRIS REGIONS.
- 3) MASONRY ANCHORS MAY BE USED INTO WOOD AS PER TABLES 2 & 3. ALL WOOD BUCKS LESS THAN 1-1/2" THICK ARE TO BE CONSIDERED 1X INSTALLATIONS. 1X WOOD BUCKS ARE OPTIONAL IF UNIT IS INSTALLED DIRECTLY TO SUBSTRATE. WOOD BUCKS DEPICTED AS 2X ARE 1-1/2" THICK OR GREATER. 1X AND 2X BUCKS (WHEN USED) SHALL BE DESIGNED TO PROPERLY TRANSFER LOADS TO THE STRUCTURE. WOOD BUCK DESIGN AND INSTALLATION IS THE RESPONSIBILITY OF THE ENGINEER OR ARCHITECT OF RECORD.
- 4) ANCHOR EMBEDMENT TO BASE MATERIAL SHALL BE BEYOND WALL DRESSING OR STUCCO. USE ANCHORS OF SUFFICIENT LENGTH. ANCHORS AND FRAME CORNERS SHOULD BE SEALED. OVERALL SEALING/FLASHING STRATEGY FOR WATER RESISTANCE OF INSTALLATION SHALL BE DONE BY OTHERS AND IS BEYOND THE SCOPE OF THESE INSTRUCTIONS.
- 5) SHIMS ARE REQUIRED AT EACH ANCHOR LOCATION WHERE THE PRODUCT IS NOT FLUSH TO THE SUBSTRATE. USE SHIMS CAPABLE OF TRANSFERRING APPLIED LOADS. WOOD BUCKS, BY OTHERS, MUST BE SUFFICIENTLY ANCHORED TO RESIST LOADS IMPOSED ON THEM BY THE WINDOW.
- 6) THE ANCHORAGE METHODS SHOWN HAVE BEEN DESIGNED TO RESIST THE WIND LOADS CORRESPONDING TO THE REQUIRED DESIGN PRESSURE. THE 33-1/3% STRESS INCREASE HAS NOT BEEN USED IN THE DESIGN OF THIS PRODUCT. THE 1.6 LOAD DURATION FACTOR WAS USED FOR THE EVALUATION OF ANCHORS INTO WOOD. ANCHORS THAT COME INTO CONTACT WITH OTHER DISSIMILAR MATERIALS SHALL MEET THE REQUIREMENTS OF THE FLORIDA BUILDING CODE FOR CORROSION RESISTANCE.

TABLE 1:

Window Buck Size		Configuration	Reinf. Level	Design Pressure		Product Rating
Width	Height			(+) psf	(-) psf	
40"	63"	Equal-lite	R4	50.0	50.0	R-PG50
52-1/8"	84"	Equal-lite	R1	50.0	50.0	LC-PG50
52-1/8"	75"	Std. ProView				
52-1/8"	86-3/8"	Custom Sash				
52-1/8"	84"	Equal-lite	R2	65.0	70.0	LC-PG65
52-1/8"	75"	Std. ProView				
52-1/8"	86-3/8"	Custom Sash				

PREPARED BY A. LYNN MILLER 1070 TECHNOLOGY DRIVE N. VENICE, FL 34275 (941) 480-1600	REGISTRATION #29296 COPYRIGHT © 2022 PGT, INC., LIMITED LICENSE TO MAKE COPIES FOR PERMITTING.	Date	06/12/11
		By	JENS ROSOWSKI
VINYL DOUBLE HUNG WINDOW (NI)		DWG No.	DH5460FPA-NI
ELEVATION & GENERAL NOTES		Sheet	1 OF 4
SERIES		Desc.	DH5460V

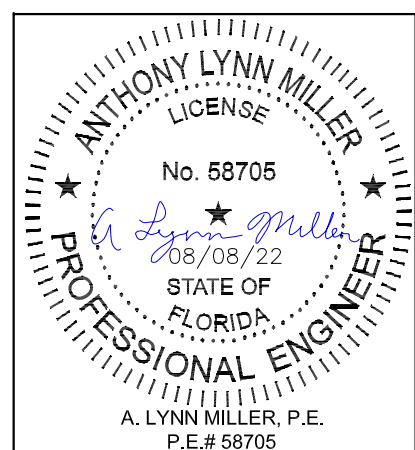

TABLE 2: ANCHORS INSTALLED THROUGH FRAME

Anchor	Substrate	Min. Edge Distance	Min. Embedment
#10 SMS (steel, 18-8 S.S.) or 410 S.S.) Max. DP of 50.0 psf	P.T. Southern Pine (SG=0.55)	7/16"	1-3/8"
	Steel, A36	3/8"	0.050"
	Steel Stud, A653 Gr. 33	3/8"	0.0346" (20 Ga.)
#12 SMS (steel, 18-8 S.S.) or 410 S.S.)	P.T. Southern Pine (SG=0.55)	9/16"	1-3/8"
	Steel, A36	3/8"	0.050"
	Steel Stud, A653 Gr. 33	3/8"	0.0346" (20 Ga.)
3/16" Ultracon Max. DP of 50.0 psf	P.T. Southern Pine (SG=0.55)	7/16"	1-3/8"
	Concrete (min. 2.85 ksi)	1"	1-3/8"
	UngROUTED CMU, (ASTM C-90)	2-1/2"	1-1/4"
3/16" Ultracon+ Max. DP of 50.0 psf	P.T. Southern Pine (SG=0.55)	7/16"	1-3/8"
	Concrete (min. 3 ksi)	1"	1-3/8"
	UngROUTED CMU, (ASTM C-90)	1"	1-1/4"
1/4" Ultracon	P.T. Southern Pine (SG=0.55)	1"	1-3/8"
	Concrete (min. 2.85 ksi)	1"	1-3/4"
	UngROUTED CMU, (ASTM C-90)	2-1/2"	1-1/4"
1/4" Ultracon+	P.T. Southern Pine (SG=0.55)	1"	1-3/8"
	Concrete (min. 3 ksi)	1-3/16"	1-3/4"
	UngROUTED CMU, (ASTM C-90)	1"	1-1/4"
1/4" Crete-Flex (410 S.S.)	P.T. Southern Pine (SG=0.55)	1"	1-3/8"
	Concrete (min. 3.35 ksi)	1"	1-3/4"
	UngROUTED CMU, (ASTM C-90)	2-1/2"	1-1/4"
1/4" Aggre-Gator (18-8 S.S.)	Concrete (min. 3.275 ksi)	1-1/2"	1-3/8"
	P.T. Southern Pine (SG=0.55)	1"	1-3/8"
	UngROUTED CMU, (ASTM C-90)	2"	1-1/4"

- "UNGROUTED CMU" VALUES MAY BE USED FOR GROUDED CMU APPLICATIONS.
- PANHEAD, FLATHEAD OR HEXHEAD ARE ACCEPTABLE.
- ANCHOR LENGTH TO BE SO THAT A MIN. OF 3 THREADS EXTEND BEYOND THE METAL SUBSTRATE.

TABLE 3: ANCHORS INSTALLED THROUGH INTEGRAL FIN

Anchor	Substrate	Min. Edge Distance	Min. Embedment
2-1/2" x .131" Common Nail Max. DP of 50.0	P.T. Southern Pine (SG=.55)	9/16"	2-7/16"
2-1/2" x .131" Ring-shank Nail	P.T. Southern Pine (SG=.55)	9/16"	2-7/16"
2-1/2" x .145" Roofing Nail	P.T. Southern Pine (SG=.55)	9/16"	2-7/16"
#10 SMS (steel, 18-8 S.S.) or 410 S.S.)	P.T. Southern Pine (SG=.55)	3/4"	1-3/8"
	Aluminum, 6063-T5	3/8"	0.050"
	Steel Stud, Gr. 33	3/8"	0.0346" (20 Ga.)
	Steel, A36	3/8"	0.050"

1) PANHEAD, FLATHEAD OR HEXHEAD ARE ACCEPTABLE.

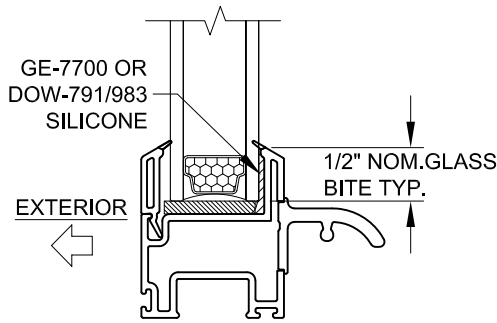

TYP. GLAZING DETAIL

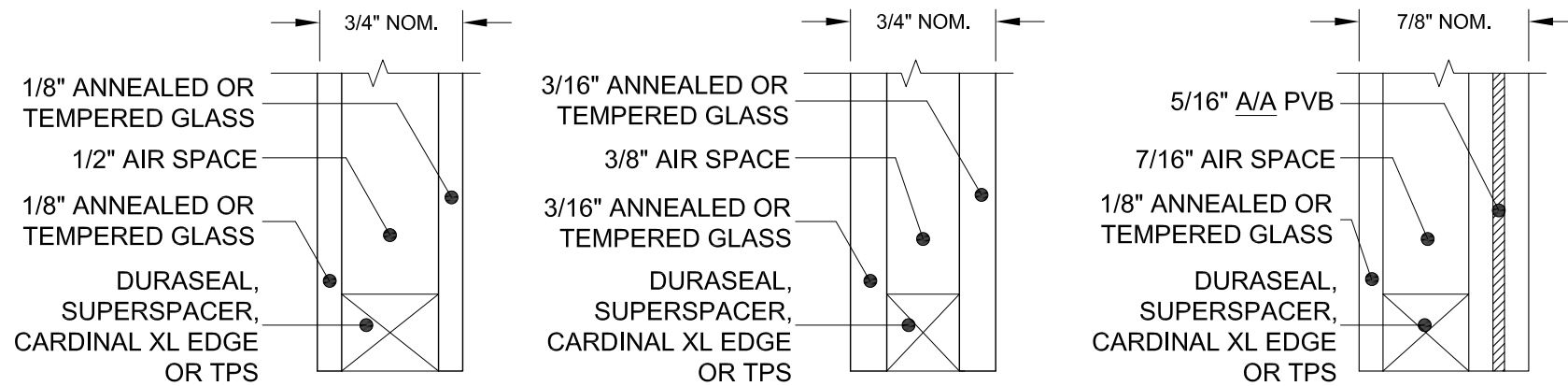

GLASS TYPES

PVB INTERLAYER MANUFACTURED BY KURARAY AMERICA, INC.

TABLE 4: REINFORCEMENT TYPES

Level	Reinforcement				
	Upper Lite		Lower Lite		
	Top Rail	Bottom Rail	Top Rail	Bottom Rail	Side Rails
R1	A	B	B	A	A
R2	A	C	C	A	A
R4	A	A	A	A	N/A

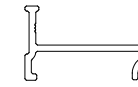

REINFORCEMENT TYPE A

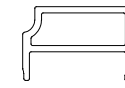

REINFORCEMENT TYPE B



REINFORCEMENT TYPE C

PREPARED BY A. LYNN MILLER 1070 TECHNOLOGY DRIVE N. VENICE, FL 34275 (941) 480-1600	REGISTRATION #29296 COPYRIGHT © 2022 PGT, INC., LIMITED LICENSE TO MAKE COPIES FOR PERMITTING.	06/12/11 Date	JENS ROSOWSKI By	DH5460FPA-NI DWG No.
	VINYL DOUBLE HUNG WINDOW (NI) ANCHORS AND GLAZING DETAILS	2 OF 4 Sheet	2 OF 4 Title	2 OF 4 Series

ANTHONY LYNN MILLER
 LICENSE
 No. 58705
 08/08/22
 STATE OF
 FLORIDA
 PROFESSIONAL ENGINEER
 A. LYNN MILLER, P.E.
 P.E.# 58705

Rev.# 08/01/22
 Date
 UPDATED CERT. METHOD
 Rev.

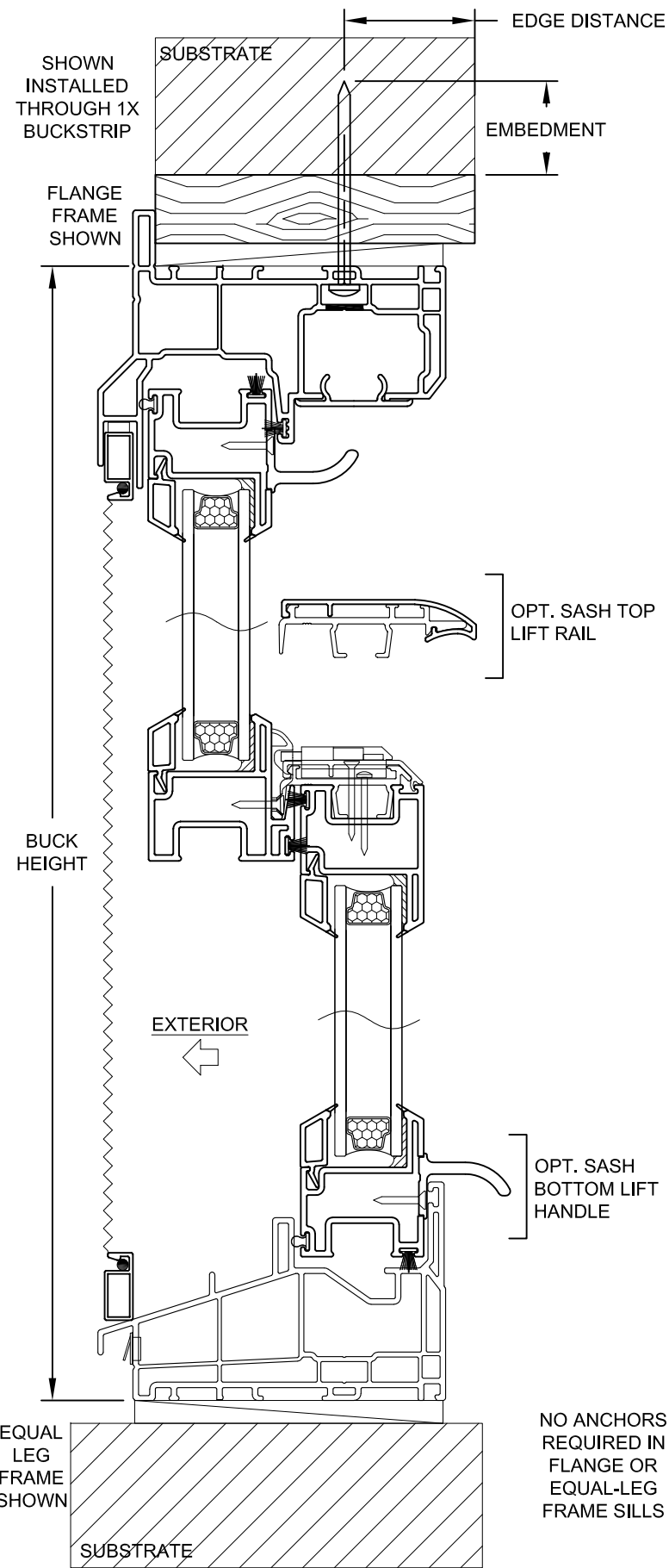

VERTICAL SECTION B-B

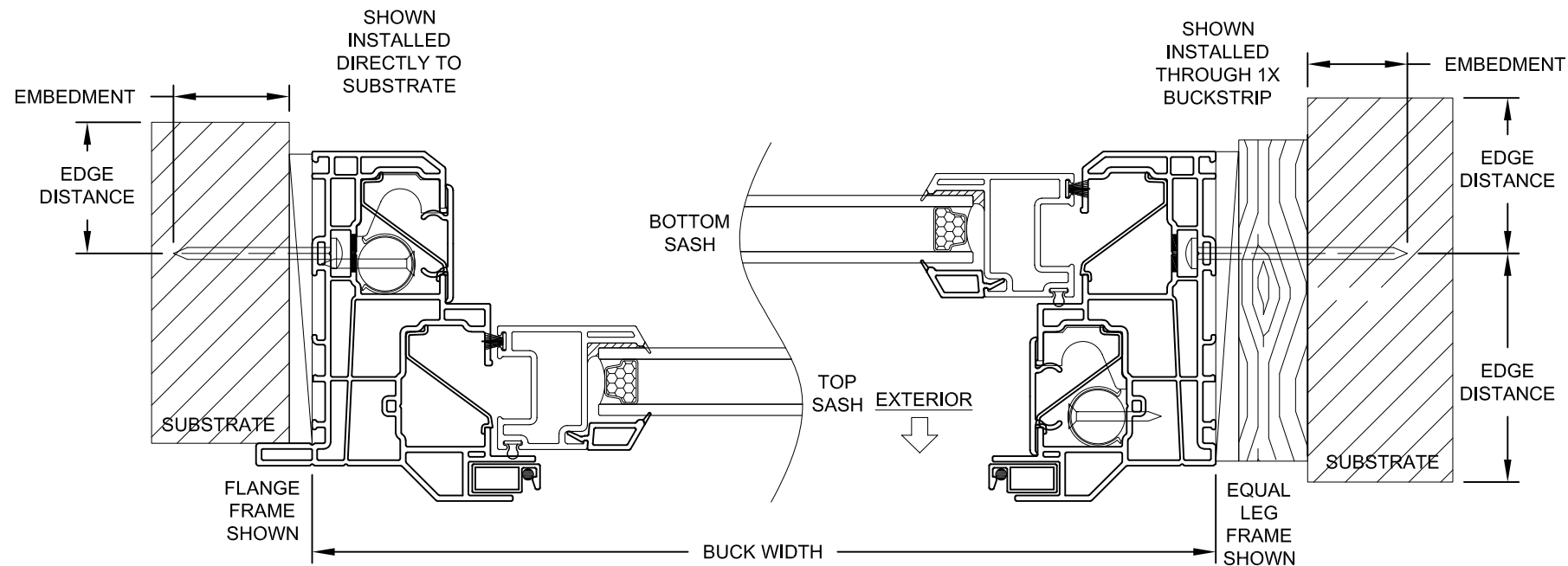

HORIZONTAL SECTION A-A

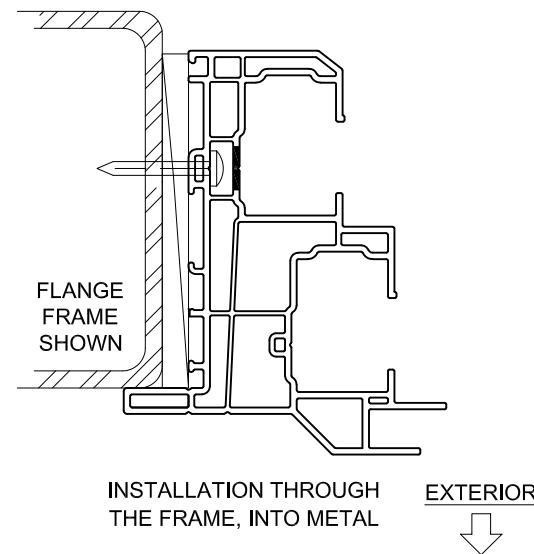

INSTALLATION NOTES:

- 1) SEE SHEET 1 FOR SPACING REQUIREMENTS.
- 2) SEE TABLE(S) ON SHEET 2 FOR ANCHORAGE AND SUBSTRATE REQUIREMENTS.
- 3) MAX. SHIM THICKNESS TO BE 1/4".
- 4) GLASS SHOWN IS FOR ILLUSTRATIVE PURPOSES ONLY AND MAY DIFFER TO MEET DESIGN REQUIREMENTS.
- 5) FIN AND/OR FLANGE MAY BE REMOVED TO CREATE OTHER FRAME TYPES.

PREPARED BY A. LYNN MILLER 1070 TECHNOLOGY DRIVE N. VENICE, FL 34275 (941) 480-1600	REGISTRATION #29296 COPYRIGHT © 2022 PGT, INC., LIMITED LICENSE TO MAKE COPIES FOR PERMITTING.	Date 06/12/11	Drawn By JENS ROSOWSKI	DWG No. DH5460FPA-NI
	1070 TECHNOLOGY DRIVE N. VENICE, FL 34275 (941) 480-1600	Series Desc. Title VINYL DOUBLE HUNG WINDOW (NI) FLANGE/EQUAL-LEG INSTALLATION	Sheet 3 OF 4	No. 3 OF 4

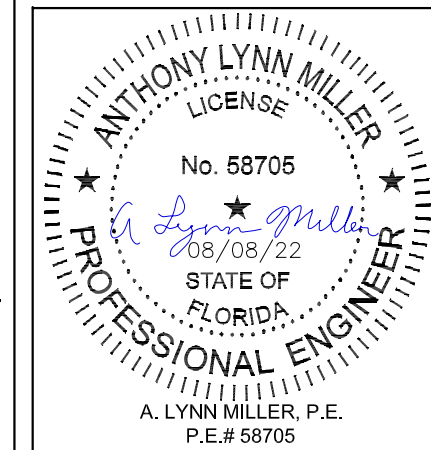

Rev. #	08/01/22
Date	
Updated Cert. Method	
Rev.	D

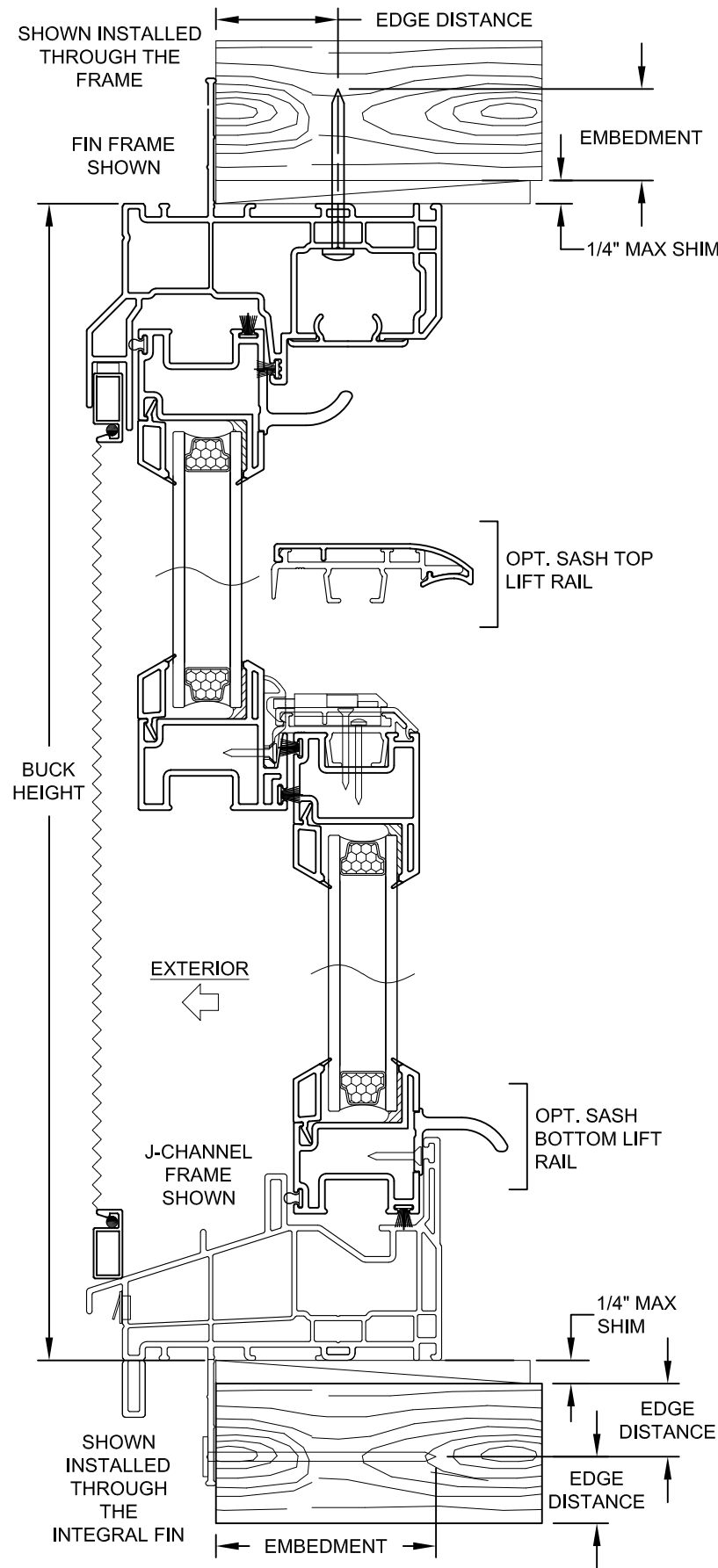

VERTICAL SECTION D-D

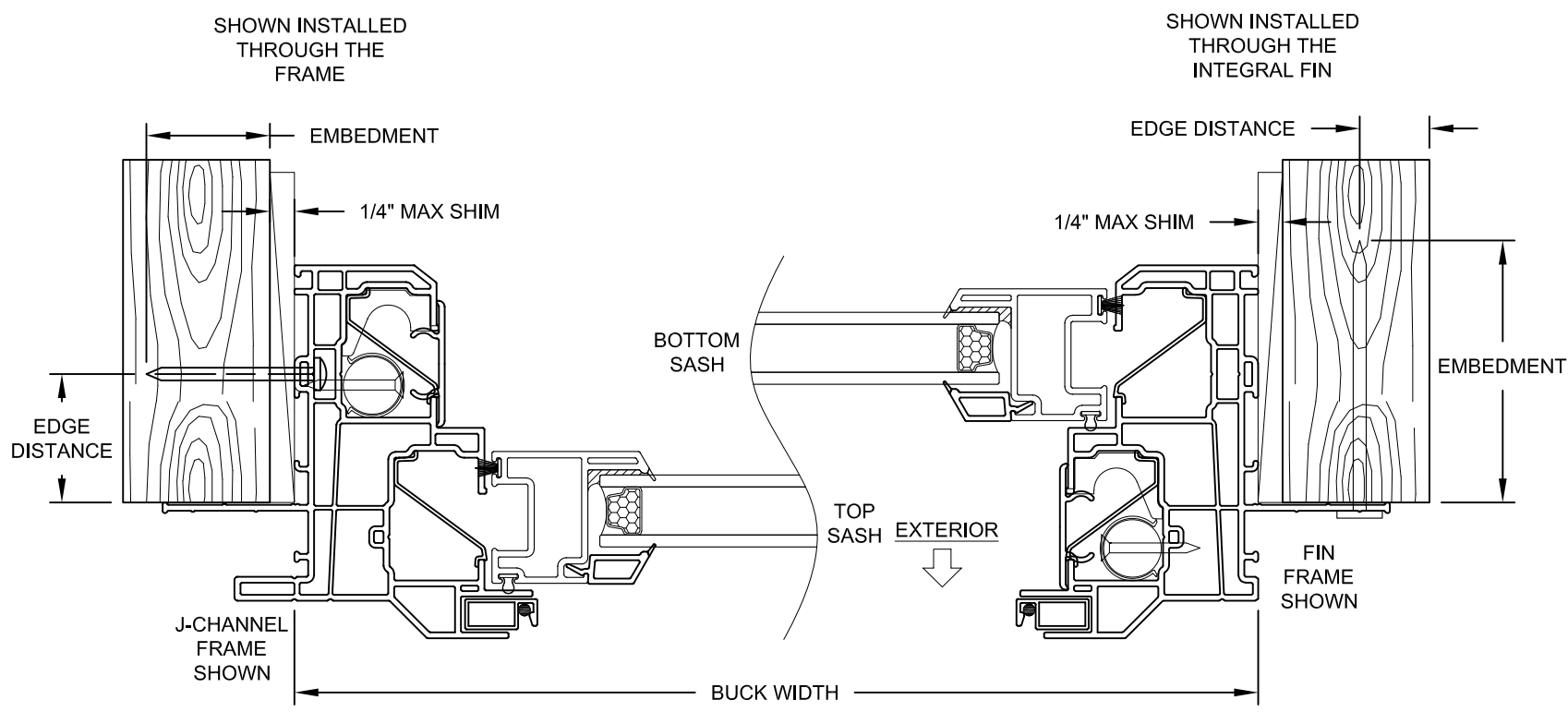

HORIZONTAL SECTION C-C

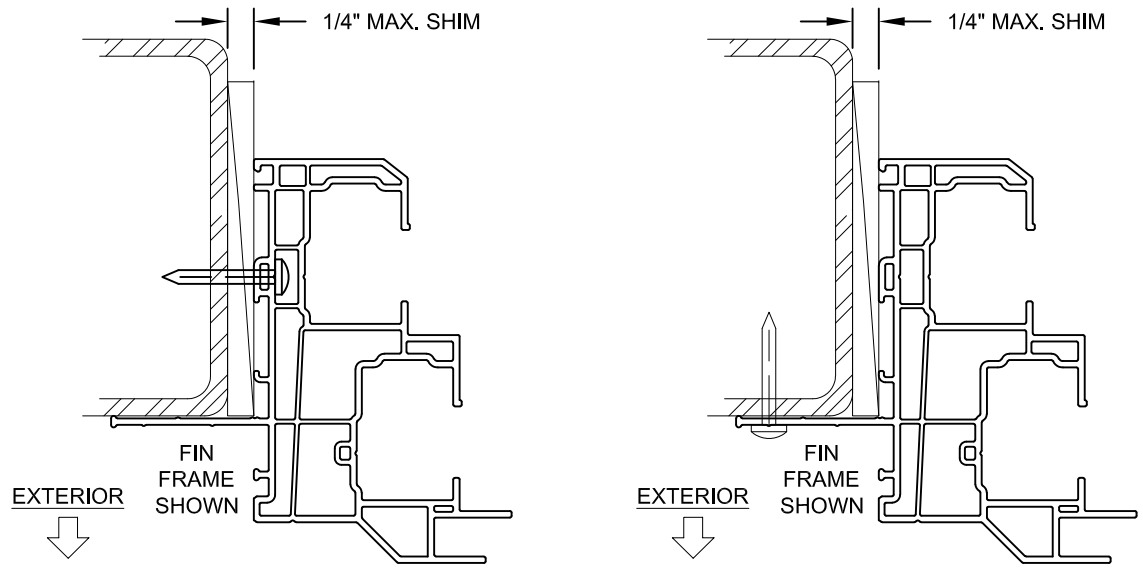

INSTALLATION NOTES:

- 1) SEE SHEET 1 FOR SPACING REQUIREMENTS.
- 2) SEE TABLE(S) ON SHEET 2 FOR ANCHORAGE AND SUBSTRATE REQUIREMENTS.
- 3) MAX. SHIM THICKNESS TO BE 1/4".
- 4) GLASS SHOWN IS FOR ILLUSTRATIVE PURPOSES ONLY AND MAY DIFFER TO MEET DESIGN REQUIREMENTS.
- 5) FIN AND/OR FLANGE MAY BE REMOVED TO CREATE OTHER FRAME TYPES.

PREPARED BY A. LYNN MILLER 1070 TECHNOLOGY DRIVE N. VENICE, FL 34275 (941) 480-1600	REGISTRATION #29296 COPYRIGHT © 2022 PGT, INC., LIMITED LICENSE TO MAKE COPIES FOR PERMITTING.	Date: 06/12/11	Drawn By: JENS ROSOWSKI
	1070 TECHNOLOGY DRIVE N. VENICE, FL 34275 (941) 480-1600	VINYL DOUBLE HUNG WINDOW (NI)	No. DWG: 4 OF 4
FIN FRAME INSTALLATION		Desc. Title: DH5460FPA-NI	

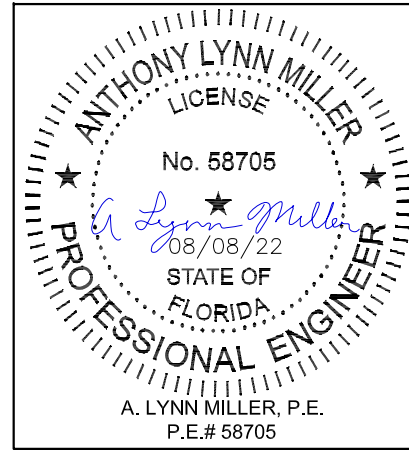

Rev. # 08/01/22
Date 08/01/22
Updated Cert. Method
D