

AWNING - LARGE MISSILE IMPACT

GENERAL NOTES:

1. THE PRODUCT SHOWN HEREIN IS DESIGNED AND MANUFACTURED TO COMPLY WITH THE FLORIDA BUILDING CODE (FBC), CURRENT EDITION INCLUDING THE HIGH VELOCITY HURRICANE ZONE (HVHZ) AND IS RATED FOR WIND ZONE 4 MISSILE LEVEL D IMPACT USE AS DEFINED IN ASTM E 1996 PER THE FBC.
2. GLAZING OPTIONS: (SEE SHEET 2)
3. CONFIGURATIONS: ALL WINDOWS ARE OPEN FROM BOTTOM TO OUTSIDE.
4. DESIGN PRESSURES:
 - NEGATIVE DESIGN LOADS BASED ON TESTED PRESSURE AND GLASS TABLES ASTM E-1300-04e01/09.
 - POSITIVE DESIGN LOADS BASED ON TESTED PRESSURE, WATER INFILTRATION TEST PRESSURE, AND GLASS TABLES ASTM E-1300-04e01/09.
5. ANCHORAGE: THE 33 1/3% STRESS INCREASE HAS NOT BEEN USED IN THE DESIGN OF THIS PRODUCT. SEE SHEET 5 FOR INSTALLATION DETAIL. WIND LOAD DURATION FACTOR Cd=1.6 WAS USED FOR WOOD ANCHOR CALCULATIONS.
6. PRODUCTS APPROVED FOR IMPACT RESISTANCE. SHUTTERS ARE NOT REQUIRED.
7. ALL FRAMES AND VENTS FULLY WELDED.
8. SERIES/MODEL DESIGNATION AW-8450.
9. THE DESIGNATION X STANDS FOR THE FOLLOWING:
X = OPERABLE SASH
10. SECTION CALLOUTS APPLY TO ALL ELEVATIONS IN A SIMILAR LOCATION.

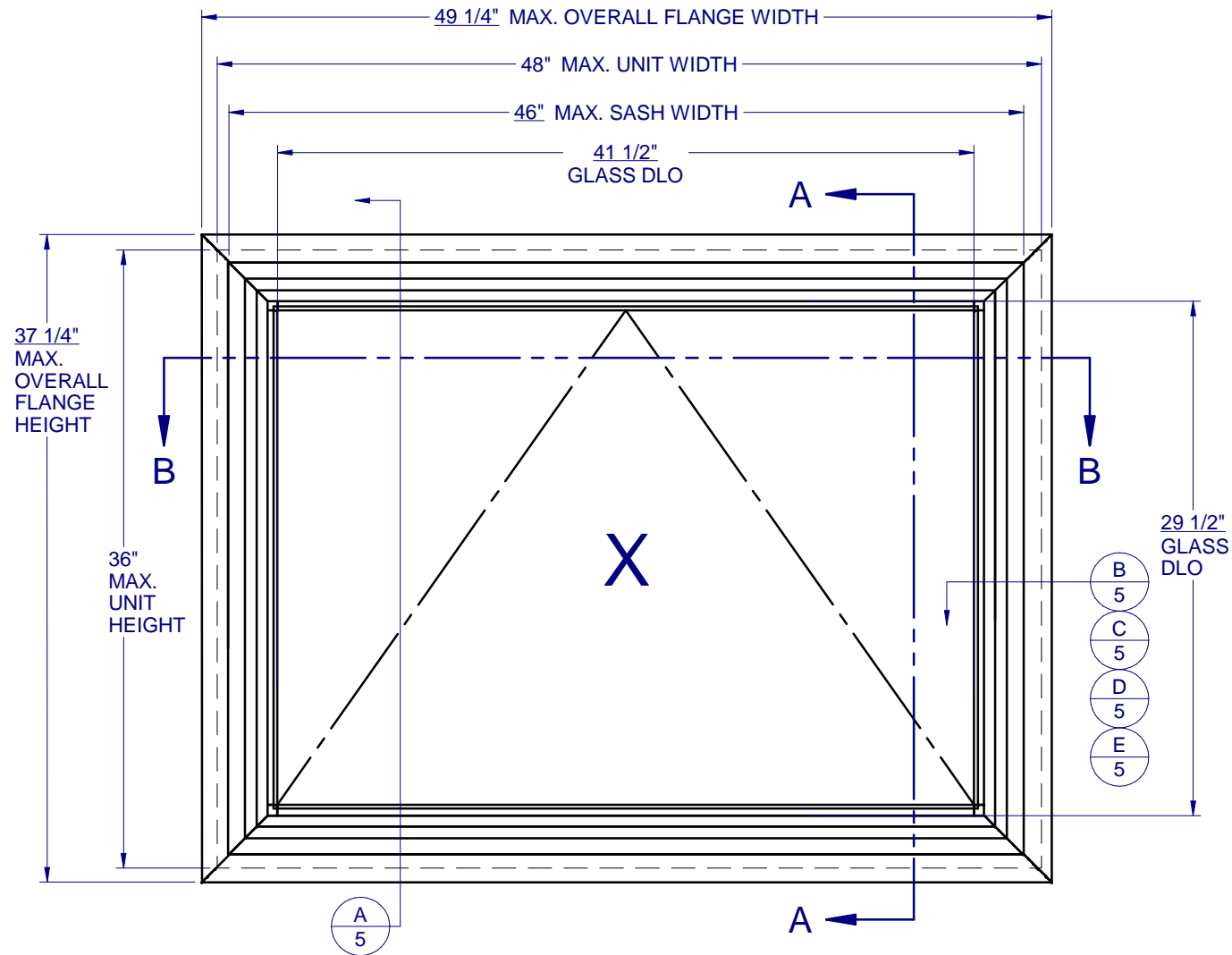

8450 PVC AWNING IMPACT

PROPRIETARY AND CONFIDENTIAL
 THE INFORMATION CONTAINED IN THIS DRAWING IS THE SOLE PROPERTY OF CUSTOM WINDOW SYSTEMS, INC. ANY REPRODUCTION IN PART OR AS A WHOLE WITHOUT THE WRITTEN PERMISSION OF CUSTOM WINDOW SYSTEMS, INC IS PROHIBITED.

FLORIDA APPROVAL NO.:
7060



8/17/2023

LUCAS A. TURNER, P.E.
 FL PE # 58201
 Turner Engineering & Consulting, Inc.
 2428 Old Natchez Trc Trl
 Camden, TN 38320
 PH. 941-380-1574

SHEET DESCRIPTION:

GENERAL NOTES AND ELEVATIONS

DRAWN BY: MCS	DATE: 8/15/2023
DWG #: CWS-163	REV.: F
SCALE: 1:10	SHEET 1 OF 5

TABLE OF CONTENTS

GENERAL NOTES & ELEVATIONS.....	1
SECTION VIEWS & GLAZING DETAIL...	2
BOM & EXTRUSIONS.....	3
ANCHOR SCHEDULE & NOTES.....	4
INSTALLATION DETAILS.....	5

LOCATION	MAX. UNIT SIZE	DESIGN PRESSURE RATING	IMPACT RATING
NON-HVHZ	48" x 36"	+/- 65 PSF	LARGE MISSILE IMPACT
HVHZ		+/- 67.5 PSF	



1900 SW 44TH AVE.
OCALA, FLORIDA 34474
WWW.CWS.CC

**8450 PVC
AWNING
IMPACT**

PROPRIETARY AND CONFIDENTIAL
THE INFORMATION CONTAINED IN THIS DRAWING IS THE SOLE PROPERTY OF CUSTOM WINDOW SYSTEMS, INC. ANY REPRODUCTION IN PART OR AS A WHOLE WITHOUT THE WRITTEN PERMISSION OF CUSTOM WINDOW SYSTEMS, INC IS PROHIBITED.

FLORIDA APPROVAL NO.:

7060



8/17/2023

LUCAS A. TURNER, P.E.
FL PE # 58201
Turner Engineering & Consulting, Inc.
2428 Old Natchez Trc Trl
Camden, TN 38320
PH. 941-380-1574

SHEET DESCRIPTION:

**SECTION VIEWS AND
GLAZING DETAIL**

DRAWN BY:	DATE:
MCS	8/15/2023
DWG #:	REV.:
CWS-163	F
SCALE:	SHEET
1:2	2 OF 5

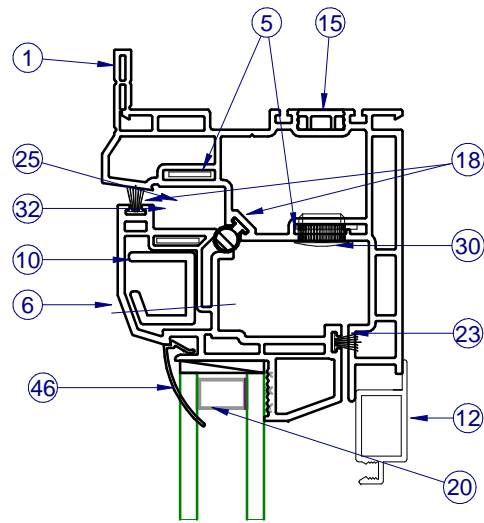

INTERIOR

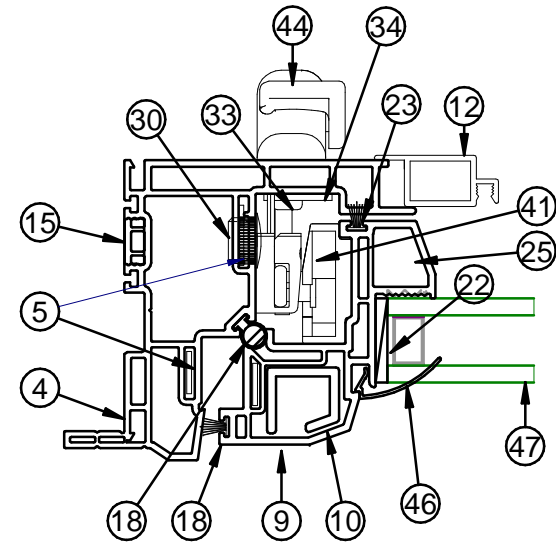

INTERIOR

SECTION VIEW B-B

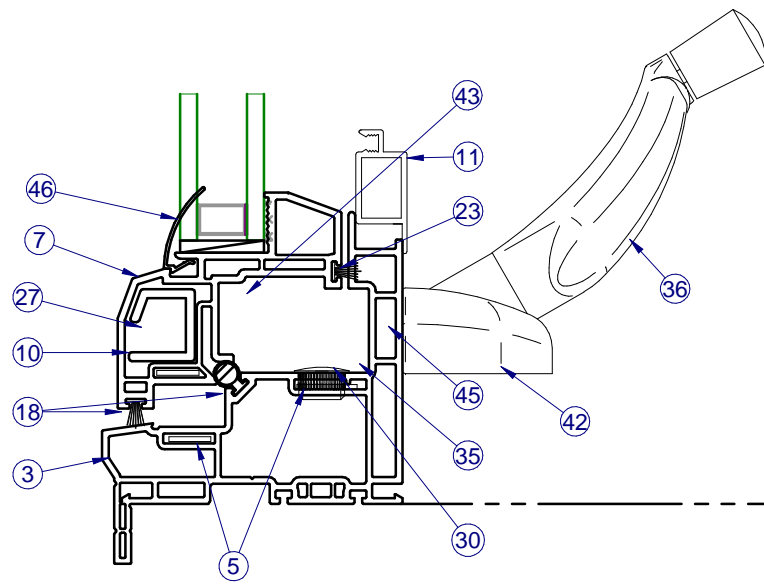
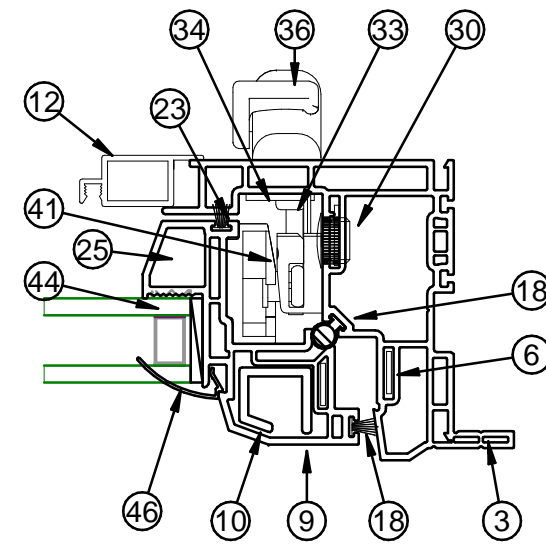

SECTION VIEW A-A

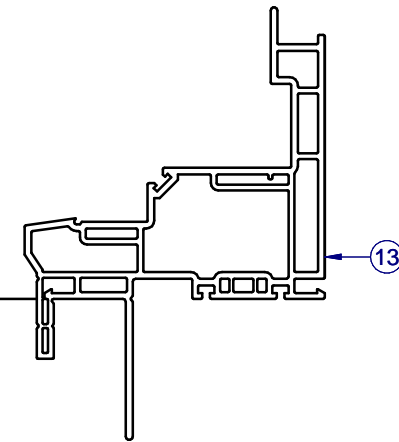

ALTERNATE FIN FRAME

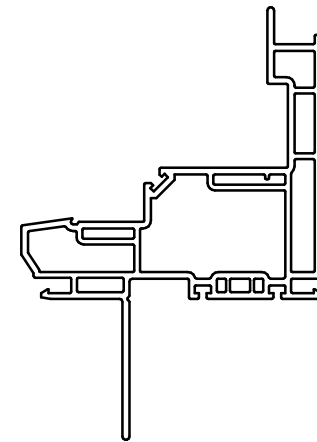

ALTERNATE FIN ONLY FRAME

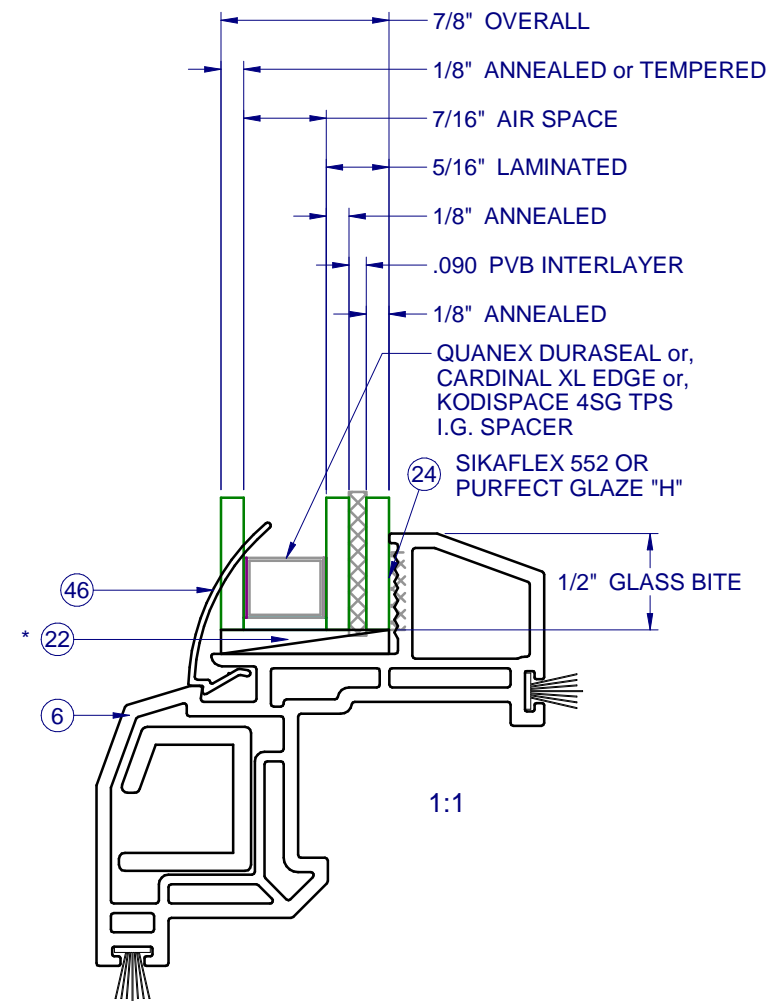

1:1

* SETTING BLOCKS PER FBC 2411.3.3.1

ITEMS NOT SHOWN FOR CLARITY:
22,25,33,38,42,46-48,51-56

ITEM	PART #	DESCRIPTION	MATERIAL
1	H-6235	FR., AWNING., MAIN, HEAD	Rigid PVC
2	H-6235	FR., AWNING, MAIN, SILL	Rigid PVC
3	H-6235	FR., AWNING, MAIN, JB., RIGHT	Rigid PVC
4	H-6235	FR., AWNING, MAIN, JB., LEFT	Rigid PVC
5	P-4050	COIL-ALUMINUM, 5052-H32 (.050 X .437) JB, LEFT	Aluminum
6	H-6234	SASH, AWNING, TOP RAIL	Rigid PVC
7	H-6234	SASH, AWNING, BOT. RAIL	Rigid PVC
8	H-6234	SASH, AWNING, SIDE RAIL, RIGHT	Rigid PVC
9	H-6234	SASH, AWNING, SIDE RAIL, LEFT	Rigid PVC
10	S-1505	REINF. AWNING, SASH SIDE RAIL LEFT	Aluminum
11	H-1592	SCREEN RAIL, SIDE	Aluminum
12	H-1593	SCREEN RAIL, TOP/BTM/SIDE	Aluminum
13	H-6235	FR., AWNING., MAIN, HEAD, W/ INTEGRAL FIN	Rigid PVC
14	P-4755	Screen Corner Key W/ Safety Pull Tab	Steel
16	P-3195	SCREEN SPRING, NO HOLE TENSION	Steel
17	P-3197	SCREEN CORNER KEY	Nylon
18	P-5573	WSTP., BULB, HOLLOW, T-SLOT, .187 X .358	Rubber
19	P-3228	SCREEN SPLINE, .155 DIA, BLK	Foam
20		SPACER, SEE SHEET 3	
21	P-3342	SEAM SEALER, SM-5504	Silicone
22	P-5612	Setting Block, .12 x 1 x 2	Rubber
23	P-3305	Wstp., .270 x .187 High Density	Nylon
24		PURFECT GLAZE "H", SIKA FLEX 552	Silicone
25	P-3539	#8 X 3/4" QUAD PH TEK, ZINC, SCREW	Steel
26	P-3565	36" - 18x14 CHARCOAL SCREEN	Fiberglass
27	P-3587	#8 X 1" PH FH TEK 2, ZINC, SCREW	Steel
30	P-5588	CAP PLUG, 1/2" HOLE	Nylon
32	P-3940	SNUBBER, SS, PVC	
33	P-4004	#8-32 X 1/2" PH PH, MS, SS (ROTO HDWE. LOCK)	Steel
34	P-4005	SUPPORT PLATE, LOCK, SS, ROTO HDWE. (Use w/ P-	Stainless
35	P-4012	SHIM, ROTO OPERATOR, ROTO HDWE. (4.8mm)	Stainless
36	P-4503	HANDLE, STD, ROTO OPER, ROTO HDWE. (WHITE)	Stainless
37	P-4015	HINGE ARM, WASHABILITY, 13", ROTO HARDWARE	Stainless
38	P-4018	HINGE TRACK, 13" ROTO HDWE., "A" & "B"	Stainless
39	P-4024	GASKET, ROTO OPER., ROTO HDWE., 1/16"	Closed Cell
40	P-4042	GASKET, LOCK	Closed Cell
41	P-4043	STRIKE, MULTI-POINT	Plastic
42	P-4510	ROTO OPERATOR, AWNING "SCISSOR"	Stainless
43	P-4045	SWIVEL BRACKET, ROTO OPER., AWNING	Stainless
44	P-4049	LOCK, SINGLE POINT (ROTO, HDWE)	Stainless
45	P-4521	#8-32 x 3/4" Phil Trilobe Truss, SS	Steel
46	S-6237	GLZ. BD.,	Rigid PVC
47	GLASS	SEE SHEET 2	

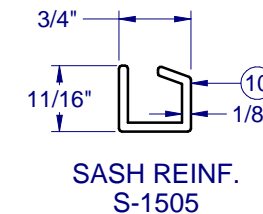
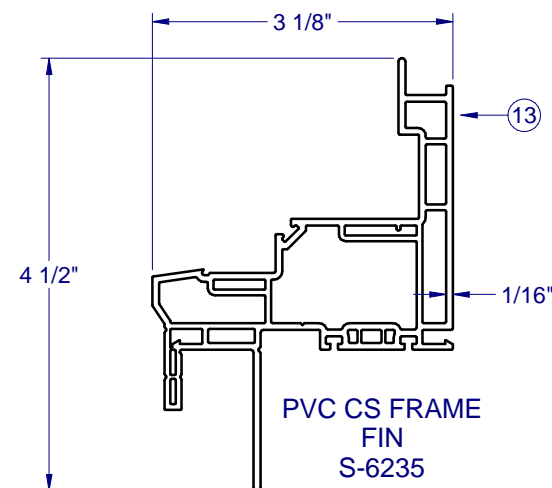
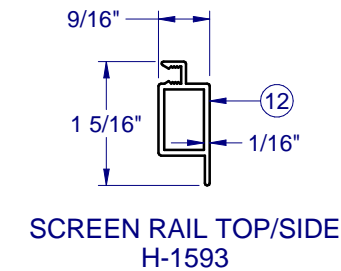
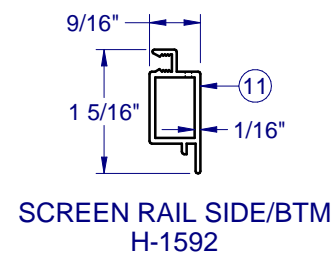
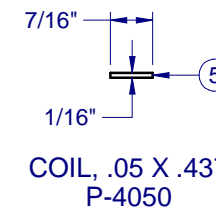
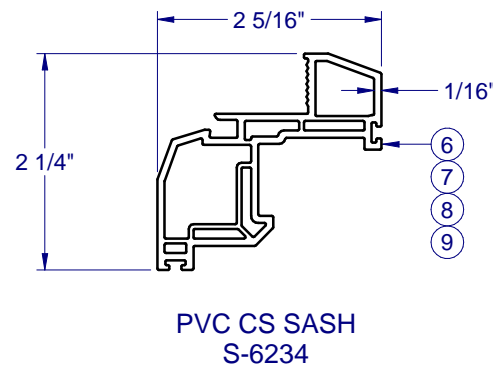
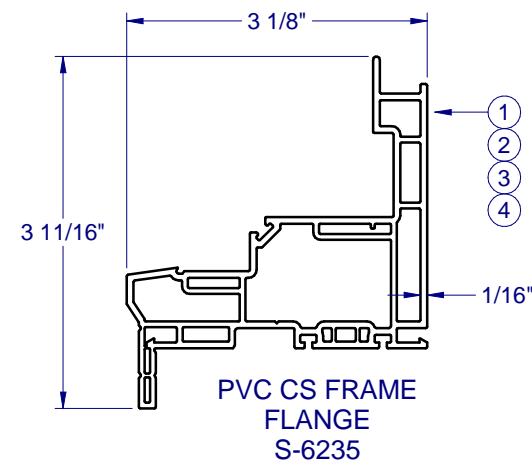

**FRAME AND
SASH CORNER
CONSTRUCTION**

CORNER WELD
(ALL SIDES)
1:8

1900 SW 44TH AVE.
OCALA, FLORIDA 34474
WWW.CWS.CC

**8450 PVC
AWNING
IMPACT**

PROPRIETARY AND CONFIDENTIAL
THE INFORMATION CONTAINED IN
THIS DRAWING IS THE SOLE
PROPERTY OF CUSTOM WINDOW
SYSTEMS, INC. ANY
REPRODUCTION IN PART OR AS A
WHOLE WITHOUT THE WRITTEN
PERMISSION OF CUSTOM WINDOW
SYSTEMS, INC IS PROHIBITED.

FLORIDA APPROVAL NO.:
7060



8/17/2023

LUCAS A. TURNER, P.E.
FL PE # 58201
Turner Engineering &
Consulting, Inc.
2428 Old Natchez Trc Trl
Camden, TN 38320
PH. 941-380-1574

SHEET DESCRIPTION:

BOM AND EXTRUSIONS

DRAWN BY: MCS	DATE: 8/15/2023
DWG #: CWS-163	REV.: F
SCALE: 1:2	SHEET 3 OF 5

NOTE: ALL ALUMINUM PROFILES ARE 6063-T6 UNLESS OTHERWISE NOTED.



1900 SW 44TH AVE.
OCALA, FLORIDA 34474
WWW.CWS.CC

**8450 PVC
AWNING
IMPACT**

PROPRIETARY AND CONFIDENTIAL
THE INFORMATION CONTAINED IN
THIS DRAWING IS THE SOLE
PROPERTY OF CUSTOM WINDOW
SYSTEMS, INC. ANY
REPRODUCTION IN PART OR AS A
WHOLE WITHOUT THE WRITTEN
PERMISSION OF CUSTOM WINDOW
SYSTEMS, INC IS PROHIBITED.

FLORIDA APPROVAL NO.:

7060

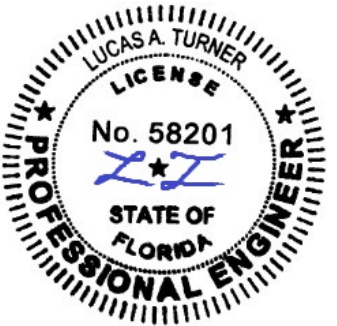

8/17/2023

LUCAS A. TURNER, P.E.
FL PE # 58201
Turner Engineering &
Consulting, Inc.
2428 Old Natchez Trc Trl
Camden, TN 38320
PH. 941-380-1574

SHEET DESCRIPTION:

**ANCHOR SCHEDULE AND
NOTES**

DRAWN BY:	DATE:
MCS	8/15/2023
DWG #:	REV.:
CWS-163	F
SCALE:	SHEET
1:12	4 OF 5

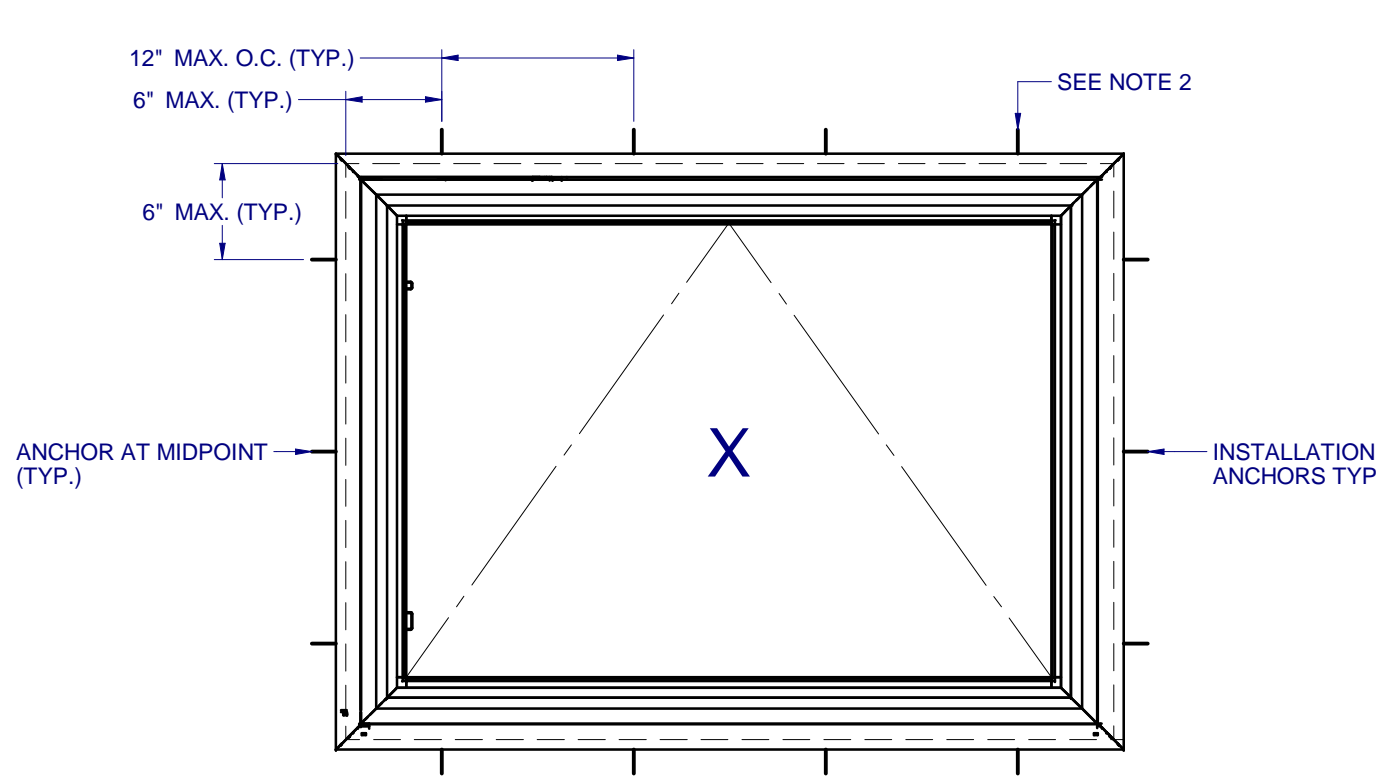

ANCHOR LAYOUT - (FLANGE)

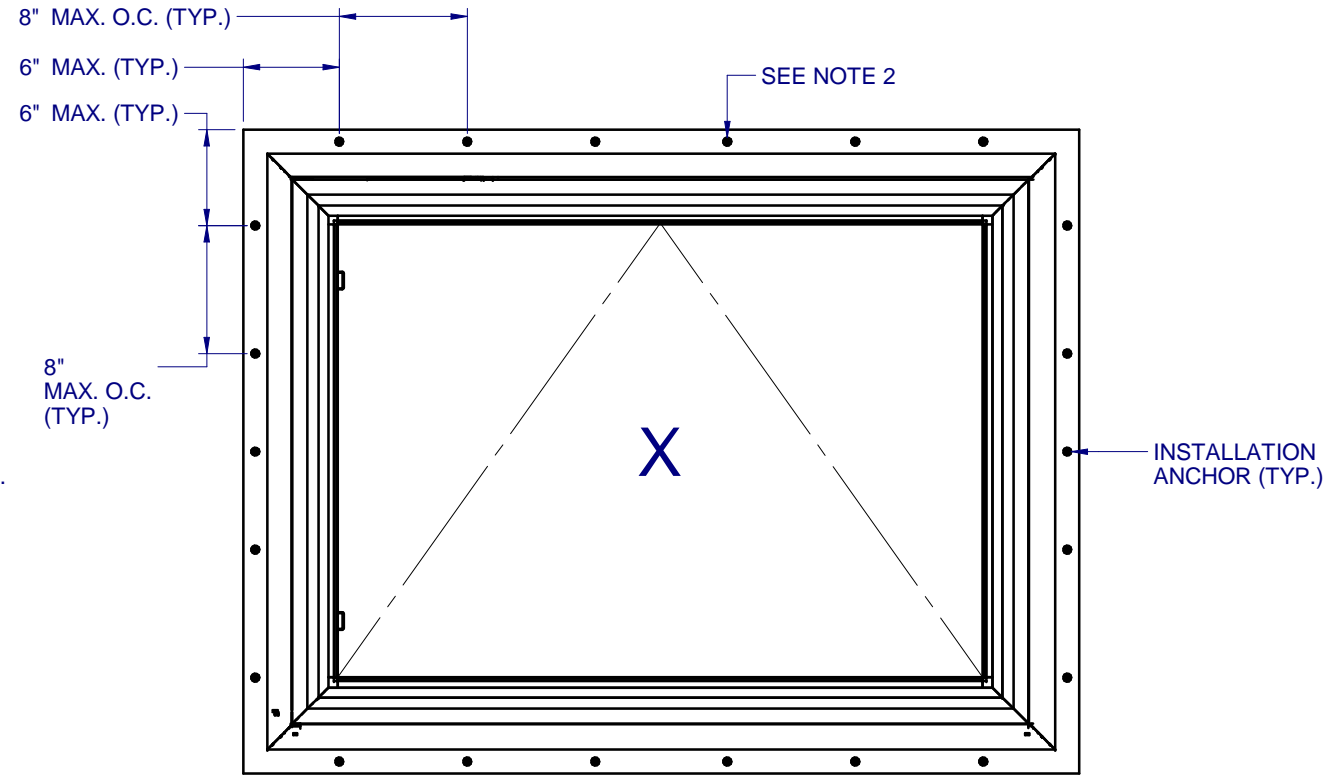

ANCHOR LAYOUT - (FIN)

NOTES:

1. INSTALL ONE ANCHOR AT EACH LOCATION. SILL ANCHOR SPACING SAME AS HEAD.
2. SHIM AS REQ'D AT EACH INSTALLATION ANCHOR USING LOAD BEARING SHIMS. MAX. ALLOWABLE SHIM STACK TO BE 1/4". USE SHIMS WHERE SPACE GREATER THAN 1/16" IS PRESENT. LOAD BEARING SHIMS SHALL BE CONSTRUCTED OF HIGH DENSITY PLASTIC OR BETTER. WOOD SHIMS ARE NOT ALLOWED.
3. ANCHOR TYPE, SIZE, SPACING AND EMBEDMENT SHALL BE AS SPECIFIED IN THESE DRAWINGS, SEE TABLE 1, SHEET 5.
4. ALL INSTALLATION ANCHORS MUST BE MADE OF OR PROTECTED WITH A CORROSION RESISTANT MATERIAL OR COATING. DISSIMILAR METALS OR MATERIALS IN CONTACT WITH PRESSURE TREATED WOOD MUST BE PROTECTED TO PREVENT REACTION.
5. INSTALLATION ANCHORS SHALL BE IN ACCORDANCE WITH ANCHOR MANUFACTURER'S INSTALLATION INSTRUCTIONS, AND ANCHORS SHALL NOT BE USED IN SUBSTRATES WITH STRENGTHS LESS THAN THE MINIMUM SPECIFIED IN TABLE 1, SHEET 5.
6. ANCHOR EMBEDMENT TO SUBSTRATE SHALL BE BEYOND WALL DRESSING OR STUCCO. FOR CONCRETE/CMU OPENINGS, EMBEDMENT SHALL BE BEYOND WOOD BUCKS, IF USED, INTO SUBSTRATE. INSTALLATIONS TO SOLID CONCRETE OR GROUT-FILLED CMU MAY INCLUDE BUT DO NOT REQUIRE 1X WOOD BUCKS BETWEEN THE PRODUCT AND THE SUBSTRATE. INSTALLATIONS TO HOLLOW CMU REQUIRE THE USE OF 1X BUCKS BETWEEN THE PRODUCT AND SUBSTRATE.
7. A MINIMUM CENTER-TO-CENTER SPACING SHALL BE MAINTAINED BETWEEN ALL FASTENERS: 3" FOR MASONRY, 1" FOR WOOD AND METAL.
8. WOOD OR MASONRY OPENINGS, BUCKS AND BUCK FASTENERS SHALL BE PROPERLY DESIGNED BY THE ARCHITECT OR ENGINEER OF RECORD AND INSTALLED TO TRANSFER WIND LOADS TO THE STRUCTURE. SUBSTRATES SHALL MEET THE MINIMUM STRENGTH REQUIREMENTS AS SHOWN IN TABLE 1, SHEET 5. CONCRETE AND MASONRY SUBSTRATES MAY NOT BE CRACKED.
9. SEALING AND FLASHING STRATEGIES FOR OVERALL WATER RESISTANCE OF INSTALLATION SHALL BE DONE BY OTHERS FOLLOWING THE CURRENT VERSION OF THE REFERENCE DOCUMENTS:
FMA/AAMA 100(FIN WINDOWS), FMA/AAMA 200(FLANGE WINDOWS), FMA/WDMA 250(BOX WINDOWS), FMA/AAMA/WDMA 300(EXTERIOR DOORS)

8450 PVC AWNING IMPACT

PROPRIETARY AND CONFIDENTIAL
THE INFORMATION CONTAINED IN THIS DRAWING IS THE SOLE PROPERTY OF CUSTOM WINDOW SYSTEMS, INC. ANY REPRODUCTION IN PART OR AS A WHOLE WITHOUT THE WRITTEN PERMISSION OF CUSTOM WINDOW SYSTEMS, INC IS PROHIBITED.

FLORIDA APPROVAL NO.:

7060



8/17/2023

LUCAS A. TURNER, P.E.
FL PE # 58201
Turner Engineering & Consulting, Inc.
2428 Old Natchez Trc Trl
Camden, TN 38320
PH. 941-380-1574

SHEET DESCRIPTION:

INSTALLATION DETAILS

DRAWN BY:	DATE:
MCS	8/15/2023
DWG #:	REV.:
CWS-163	F
SCALE:	SHEET
1:2	5 OF 5

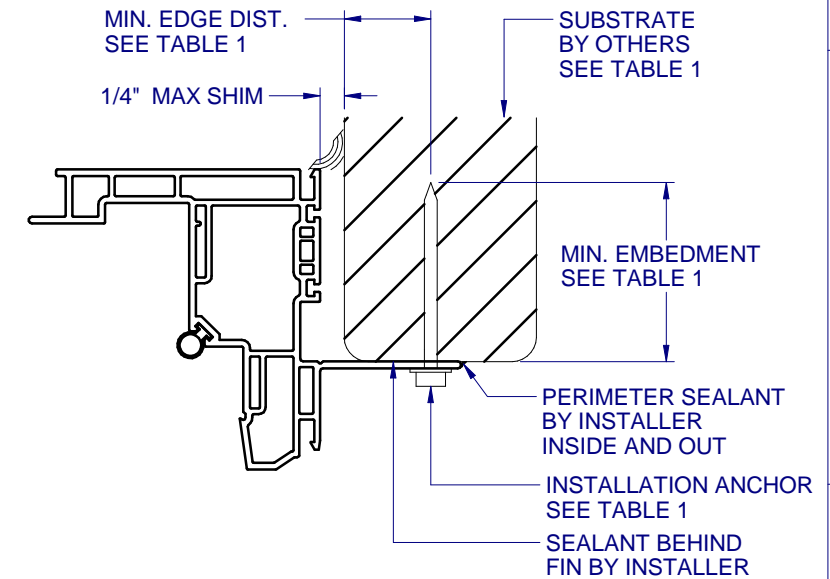
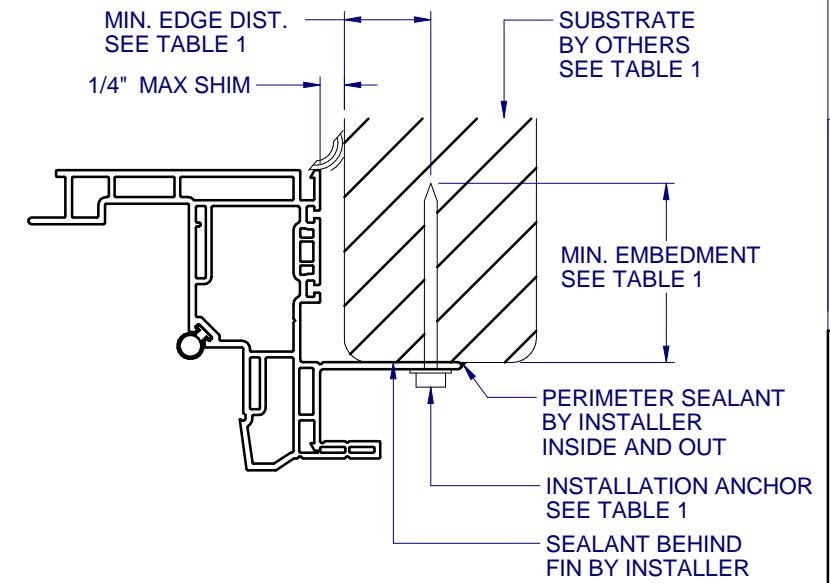
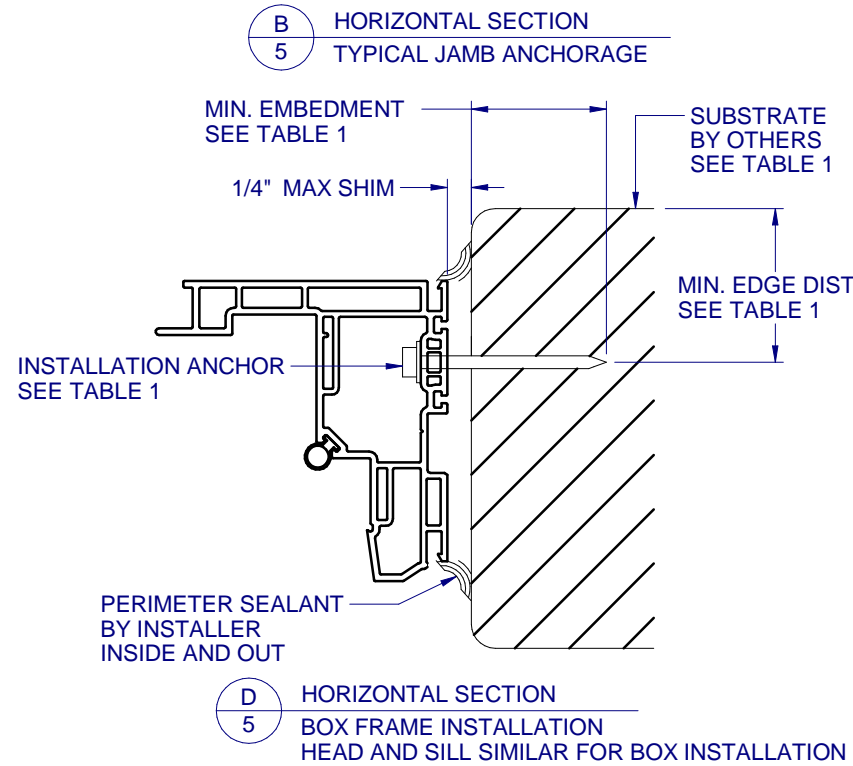
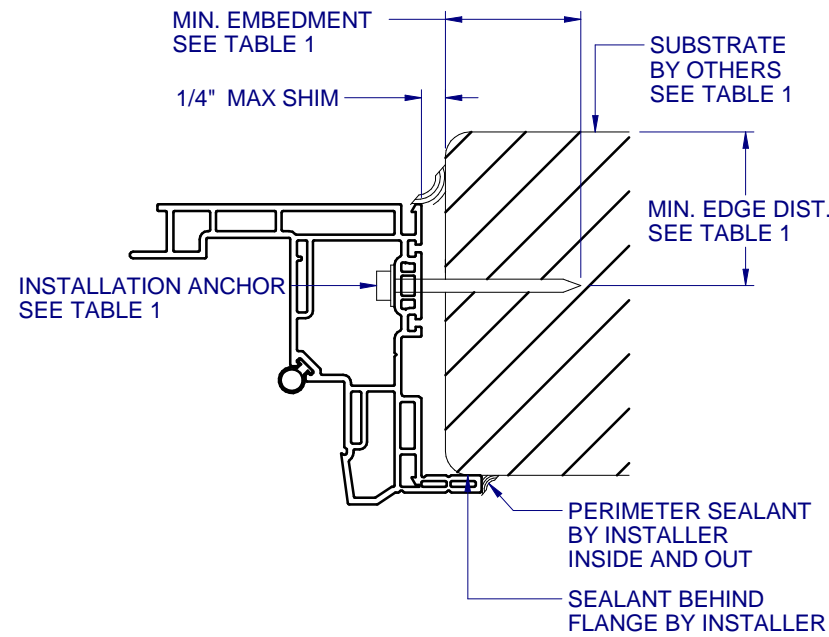
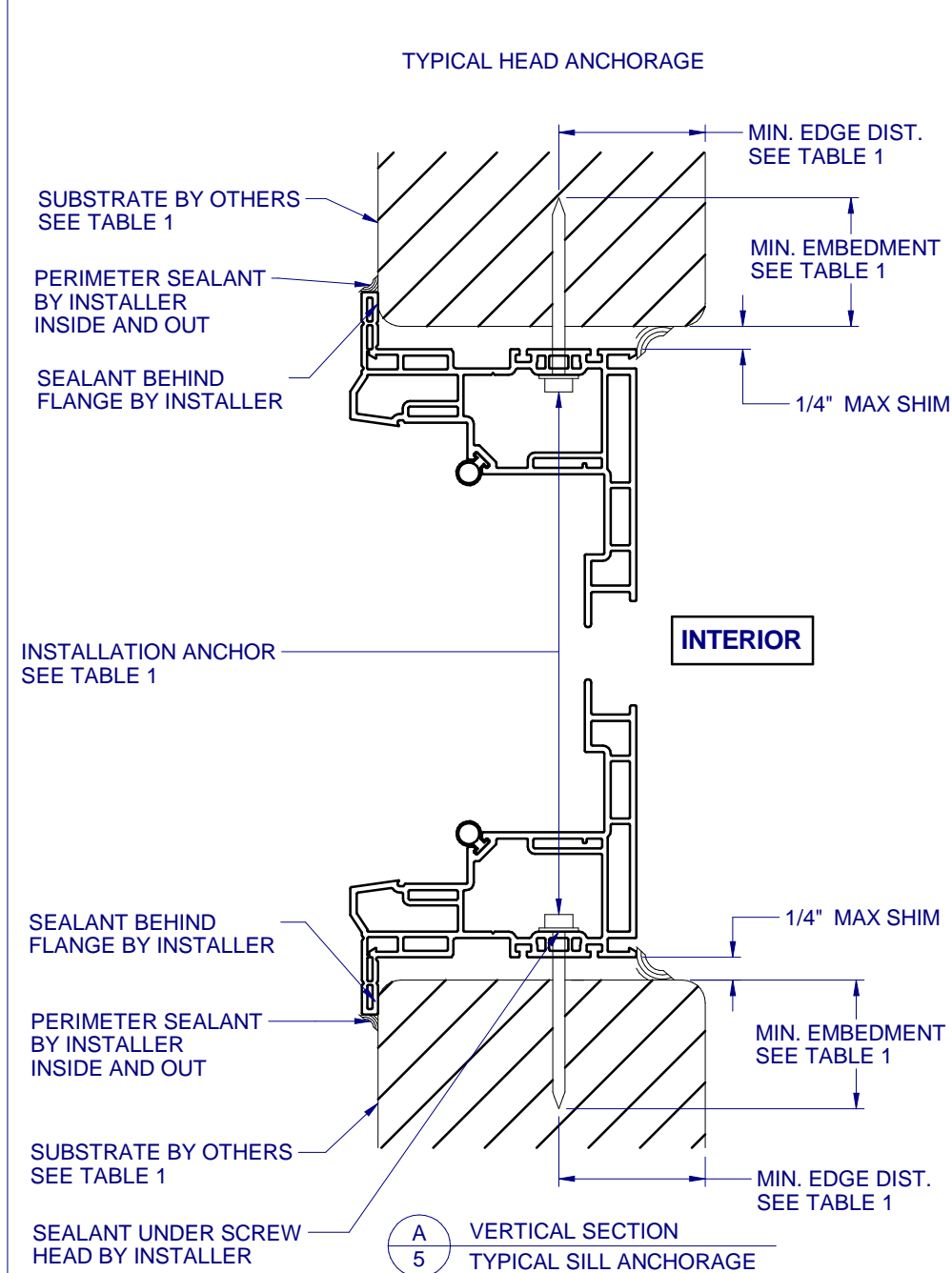

FRAME TYPE	SUBSTRATE TYPE	ANCHOR TYPE	MIN. EMBEDMENT	MIN. EDGE DIST.
FLANGE	CONCRETE (2.0 KSI MIN.)	3/16" ITW TAPCON	1"	1-1/8"
FLANGE	HOLLOW OR GROUT-FILLED CMU (117 PCF MIN.)	3/16" ITW TAPCON	1"	2"
FLANGE	CONCRETE (3.05 KSI MIN.)	3/16" DEWALT ULTRACON+	1-3/4"	1"
FLANGE	HOLLOW OR GROUT-FILLED CMU (ASTM C-90)	3/16" DEWALT ULTRACON+	1-1/4"	2-1/2"
FLANGE	2X MIN. SPRUCE-PINE-FIR (G=0.42)	3/16" ITW TAPCON OR DEWALT ULTRACON+	1-3/8"	7/8"
FLANGE	2X MIN. SPRUCE-PINE-FIR (G=0.42)	#10 WOOD SCREW	1-3/8"	7/8"
FLANGE	16 GAUGE (0.060") MIN. STEEL STUD (33 KSI YIELD MIN)	#10-16 HILTI KWIK-FLEX OR ITW TEKS SELF-DRILLING SCREW	FULL THREAD THRU 0.060"	7/16"
FLANGE	1/8" ALUM. (6063-T5 MIN.) OR 1/8" STEEL (33 KSI MIN.)	#10 GRADE 5 SELF-TAPPING / DRILLING SCREW	FULL THREAD THRU 0.125"	7/16"
FIN	2X MIN. SPRUCE-PINE-FIR (G=0.42)	#8 WOOD SCREW	1-1/2"	7/16"

FLANGE REMOVAL NOTE: PARTIALLY OR FULLY REMOVING THE FLANGE, UP TO AND INCLUDING A BOX-FRAME APPLICATION IS ACCEPTABLE PROVIDED:

- MIN. 1/4" FILLET OF CONSTRUCTION-GRADE ADHESIVE CAULK IS APPLIED INSIDE AND OUT, FULL PERIMETER, BY INSTALLER.
- PRODUCT ANCHORAGE IS IN ACCORDANCE WITH REQUIREMENTS AS SHOWN FOR FLANGE WINDOWS.