

# Cedarlite® 600 and Madera 700/900

## INSTALLATION GUIDE



**GENERAL:**

Cedarlite® 600 and Madera 700/900 have four different shake detail patterns and it is suggested that they be applied in a random, broken-bond with a minimum 3" offset (see detail #1) between the sidelaps of adjacent courses. Sidelaps in alternate courses shall not be in direct alignment.

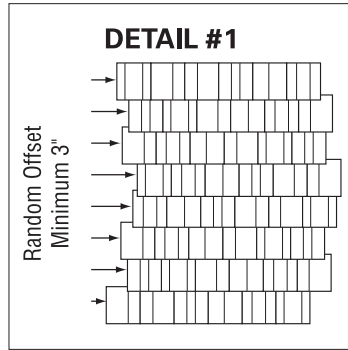

Due to the irregular nose treatment of this tile, a maximum 10-inch exposure is allowed in order to maintain a minimum 3-1/2" headlap.

**PITCH SPECIFICATIONS:**

Cedarlite® 600 and Madera 700/900 may be installed down to a minimum 2-1/2:12 slope.

On roof slopes less than 3:12, an approved underlayment system is required as per the current TRI/WSRCA Installation Manual. An Elevated Batten System® or counter-batten system (see detail #4) is also required on slopes less than 3:12.

**SHEATHING AND BATTENS:**

Cedarlite® 600 and Madera 700/900 may be installed over solid decking, onto battens over solid decking or on battens over spaced sheathing. (See the TRI/WSRCA Installation Guide). Nailing of substrate must be done in accordance with IBC or TRC requirements as applicable.

There are four methods to accomplish this:

1. Sheathing should be plywood or equivalent, as approved by local building department, nominal 1/2" thickness with adequate support at laps to prevent deflection (see detail #2).

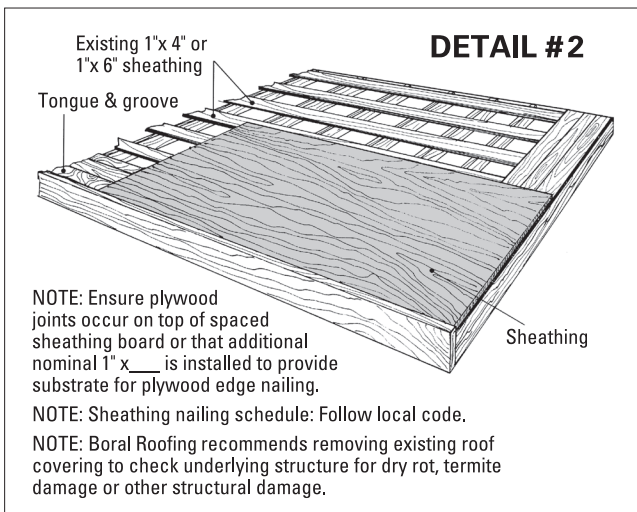

2. Fill in skip sheathing (see detail #3).

**CAUTION:** When this system is used, care must be taken to ensure that nails penetrate the roof deck.

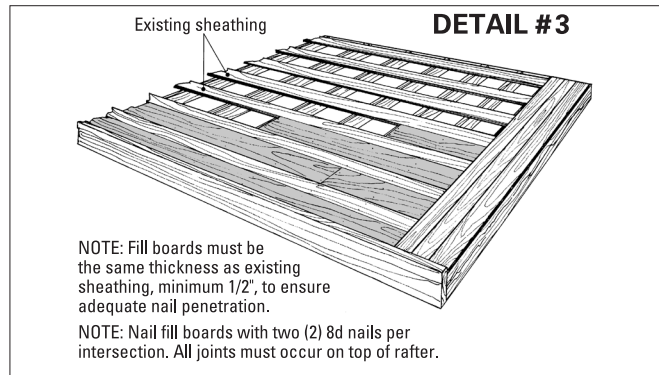

3. Counter-battens with approved, sealed underlayment system and 1" x 3" battens for roof pitches less than 3:12. Eave riser metal should be installed with this system to cover counter-battens (see detail #4).

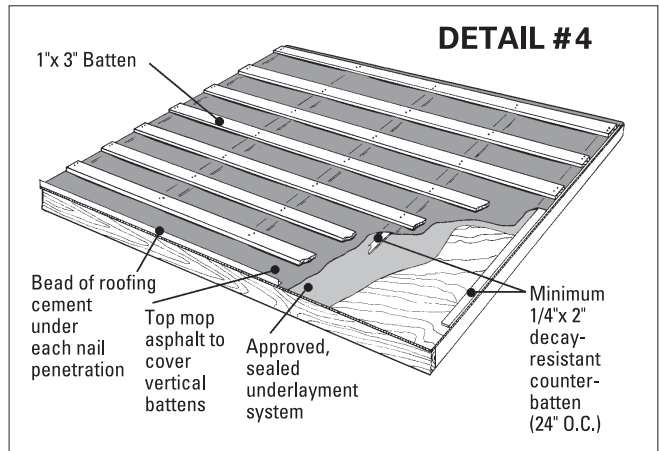

4. Elevated Batten System® (EBS) may be used as an alternative to standard battens or counter battens (see detail #4a).

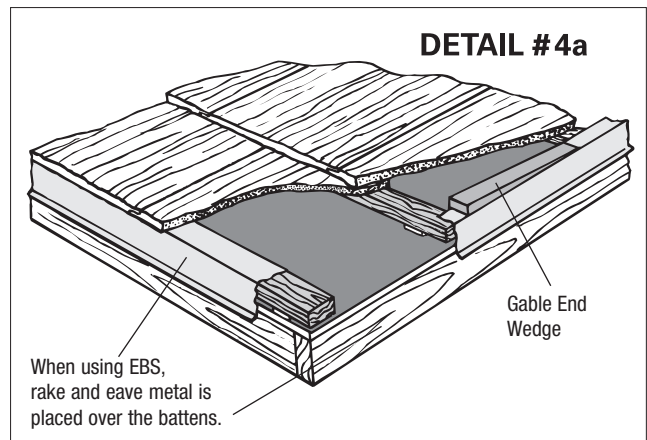

**UNDERLAYMENT:**

Cedarlite® 600 and Madera 700/900 require a minimum ASTM Type 30 single layer of asphalt underlayment or approved equivalent, in accordance with the provisions of the TRI Installation Manual, ICC ESR 2015P. Sidelaps shall be no less than 6” and headlap no less than 2”. Alternate underlayment course sidelaps are to be staggered.

Refer to manufacturer’s guidelines for alternative underlayment installation requirements.

All penetrations or cuts through the underlayment, e.g. vents, stacks, skylights, etc., must be sealed in accordance with acceptable roofing practice and local codes. Underlayment must be completely watertight before Cedarlite® or Madera 700/900 is installed.

On roof pitches less than 3:12, a local building department approved, sealed underlayment system is required.

**COURSING:**

Cedarlite® 600 and Madera 700/900 may be laid with a variable headlap to prevent cutting of the top course. The use of a premarked layout tape with 10” coursing will maintain the minimum 3-1/2” headlap. The first course is marked at a maximum of 12-1/2” from the edge of the roof, and the last course is marked 1/2” from the nailer board or 1” from the center of the ridge. Hold the layout tape perpendicular to the eave and swing the tape until the top mark is 1/2” from ridge board to mark course spacing (see detail #5).

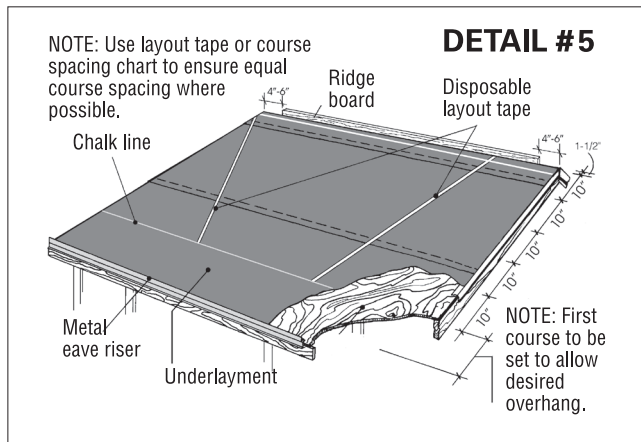

**LOADING:**

The method of roof loading shown (see details #6, #7, #8) represents one method of placement for efficient application but is not intended to suggest that this is the only method that will work. Each applicator will have personal preferences for stack location and spacing. The important aspect of loading is to spread the load evenly across the roof while using proper increments that assure that the proper amount of tile is loaded on the roof.

**TYPICAL GABLE ROOF**

Lay out stacks beginning from the ridgeline down to the eaves. Place stacks 22 inches apart and always start at the right side.

Repeat procedure every other course thereafter. Do not load stacks on the first course from the eave.

Detail #6 represents a roof with an odd number of courses, placing six tiles in a stack along the eave course. If there is an even number of courses on the roof, the tiles will need to be stacked in stacks of twelve on the ridge.

See detail #6 for number of tiles per stack.

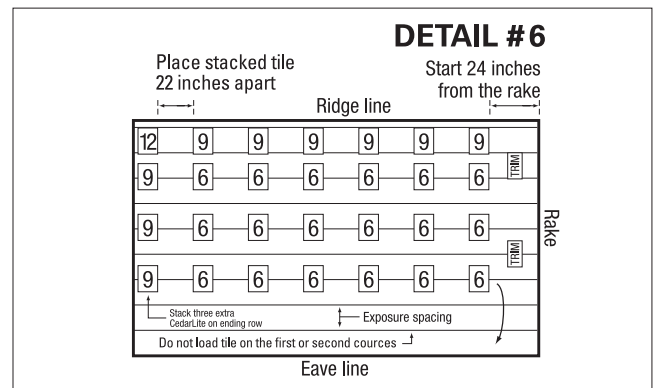

**TYPICAL HIP ROOF:**

Lay out stacks beginning from the eave up. Place stacks on the second or third course from the eave and at every other course up to the top of the hip. Place stacks 22 inches apart and always start from the right side.

Stacks which sit next to the hip line should have twelve tiles to compensate for the cut pieces that will be filled in.

Number of tiles in stacks at far left may vary due to roof size.

See detail #7 for number of tiles per stack.

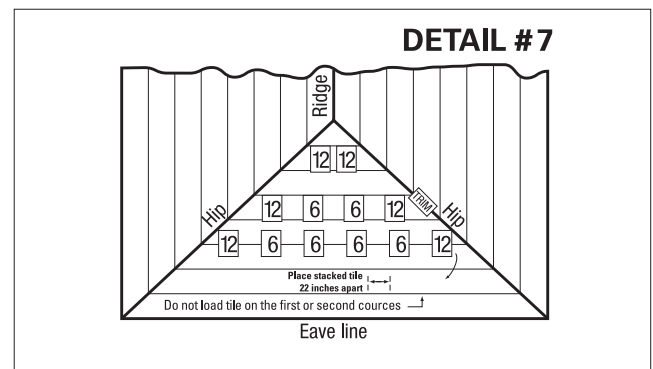

**TYPICAL VALLEY ROOF:**

Lay out stacks beginning from the ridgeline down to the eaves. Place stacks 22 inches apart and always start at the right side. Repeat procedure at every other course thereafter. Do not load stacks on the first course from the eave. Stacks which sit next to the valley should have three extra pieces to compensate for the cut pieces that will be filled in. Do not load product within the 24 inch valley zone where the valley metal will be placed.

Number of tiles next to the valley will vary due to roof size.

See detail #8 for number of tiles per stack.

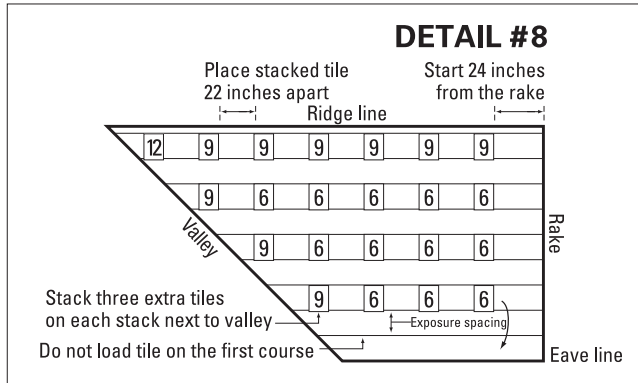

**EAVE TREATMENT:**

The butt end of the tile shall extend beyond the eave approximately 1".

There are three options to install the eave course as below:

- A. **Cedarlite® 600 or Madera 700/900 Starter:** Cover all exposed plywood with drip edge. The underlayment will overlap the drip edge. Install Starter at desired overhang with textured side down (see detail #9).

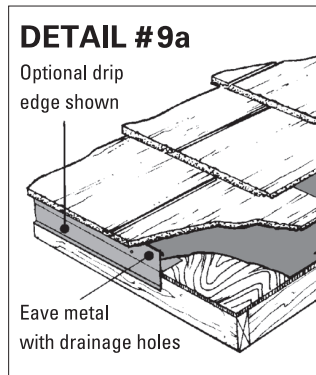
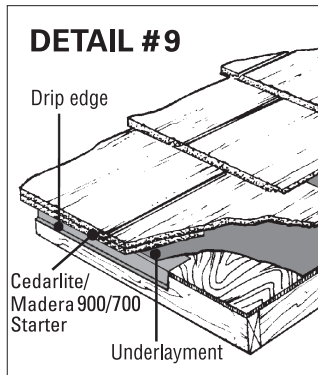

- B. **Metal Eave Riser:** Install the 7/8" eave riser "T" metal to cover all exposed plywood. The underlayment will overlap the flange of the metal (see detail #9a).

C. **Non-Raised Fascia:**

Cover all exposed plywood with drip edge. A 1"x 2" strip of cedar, redwood or pressure-treated lumber should be installed at the eave to provide adequate support and angle for the first course. This strip should not extend into the valley or pan flashings. An anti-ponding system must be installed behind the starter board. The underlayment shall overlap the starter completely (see detail #10).

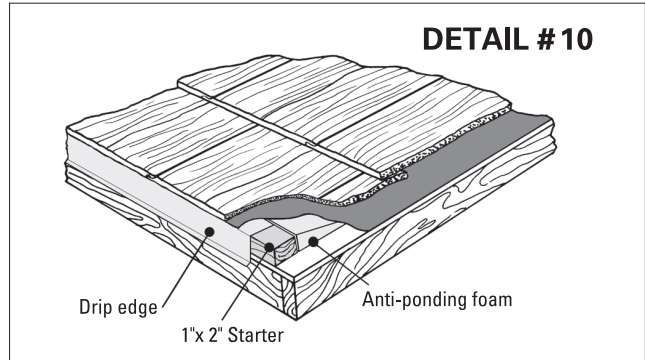

D. **Raised Fascia:**

In the case where raised fascia is applied, the fascia board shall be set at 7/8" above the extended plane of the roof deck in order to provide adequate support and angle for the first course of tile. The anti-ponding must be installed prior to the installation of any underlayment. The underlayment will overlay the raised fascia (see detail #11).

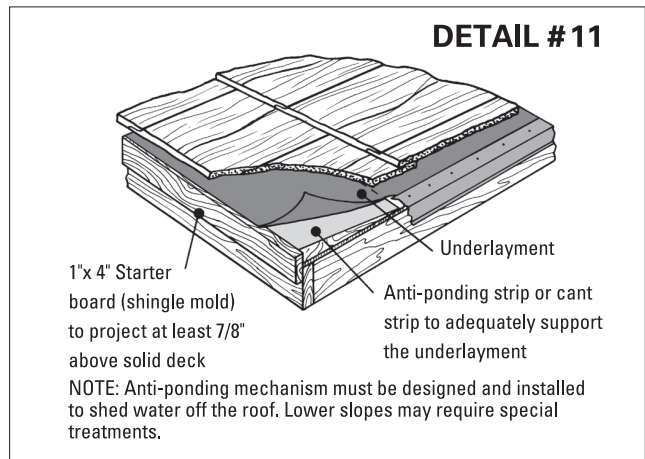

**PIPE FLASHING:**

Install the base flashing in shingle fashion with the underlayment. Seal all penetrations through underlayment.

The primary flashing must be installed shingle fashion with a minimum 3" headlap (see detail #12).

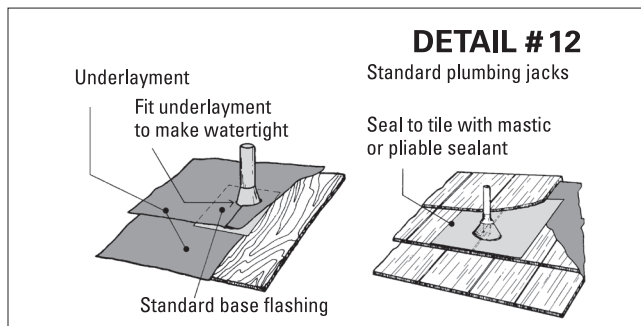

**FASTENING:**

**NOTE: Lightweight products Cedarlite® 600 and Madera 700 are not recommended for areas likely to experience winds in excess of 80 mph.** If Cedarlite® 600 or Madera 700 are to be used in high wind areas, tiles must be attached with a minimum of two screws, wind clips, and adhesive in accordance with local building codes.

Standard Weight tile, Madera 900, should be installed in accordance with TRI Installation Guide, Table 1A.

The building code requires that all products without lugs be secured with fasteners of sufficient length to penetrate at least 3/4" into the sheathing or through the sheathing whichever is less. Cedarlite® 600 and Madera 700 are applied with a minimum of two (2) corrosion-resistant nails. The fastener head size shall be no smaller than 5/16". An equivalent fastening method is one (1) 2" corrosion-resistant #8 bugle head screw. The fastener head is driven to a point that allows the face end of the tile to lift 1/4 to 1/2 inch above the tile below.

In certain areas it is impossible to secure the tile with nails (under flashings). In these areas tile must be secured with an approved concrete adhesive.

When battens are used, the top edge of the tile should align evenly with the top edge of the batten. Batten size should be a minimum 1"x 3" to provide proper fastener penetration into the batten.

**RAKE OR GABLE END TREATMENT:**

There are three options to complete the gable edge of the roof:

- A. The underlayment overlaps the edge of the roof by a minimum 3/4". Metal rake trim with a ribbed pan closes the cut edge of the tile. Tiles are cut flush to the inside edge of the flashing (see detail #13).

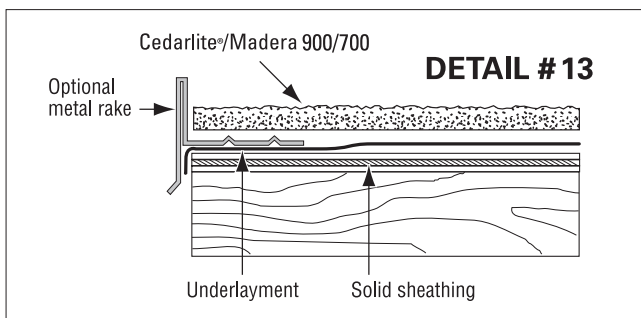

- B. The underlayment overlaps the edge of the roof by 1". tile is applied flush to the gable edge. Rakes are fastened with two corrosion-resistant fasteners of sufficient length to penetrate 3/4" into the barge rafter (see detail #14).

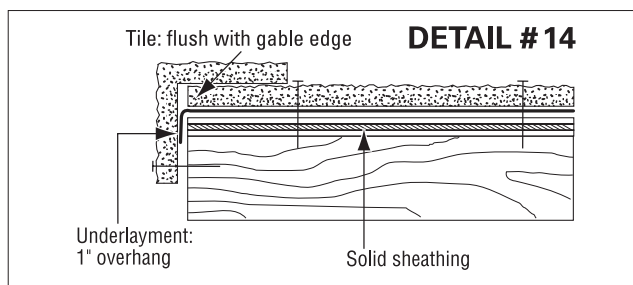

- C. The underlayment overlaps the edge of the roof by a minimum 3/4". A metal drip edge flashing is installed along the gable ends of the roof of sufficient size to cover the exposed edge of the plywood. An optional 3/4" impregnated foam strip or metal wedge may be fastened to provide a rake closure (see detail #15).

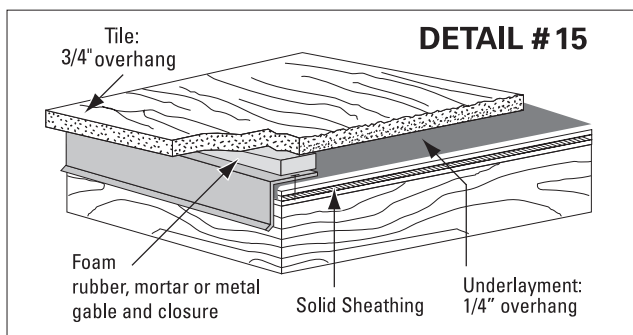

Each course will extend at least 3/4" over the edge of the roof. It is important to cut each rake course to ensure desired aesthetics. Rake shakes will vary in width to maintain random broken-bond pattern.

**Small cut gable pieces must be secured in accordance with good roofing practice.**

**NOTE:** Rain channels/sidelocks are to be removed on all rake pieces where they overhang the barge rafter or gable end.

**VALLEY TREATMENT:**

Underlayment may be woven through the valley before the metal is installed or a single layer of 36" wide underlayment shall be centered in the valley and applied the full length of the valley prior to the placement of the valley metal. The underlayment may be lapped over the edge of the valley metal or woven across the valley beneath the valley metal. Ribbed valley metal is recommended for use to control water flow and support the tile extending into the valley. Flashing sections should be lapped at least 6-inches and secured to prevent movement. No fasteners should penetrate the flashing within 10-inches of the center of the valley. The outside edges may be sealed with roofer's cement or pressure-sensitive adhesive. Tiles may be cut close to center of the valley but in areas subject to heavy debris accumulation, it may be better to cut tiles away from the center to allow for cleaning. Cut tiles that cannot be fastened without penetrating the flashing should be attached with wire and/or adhesive or cut tile clip.

A double-ribbed valley may be used in place of sealing the edge of the valley flashing.

**Small cut pieces must be secured in accordance with good roofing practice.**

Tiles cut close to the center diverter must be installed over ribbed valley metal (see detail #16).

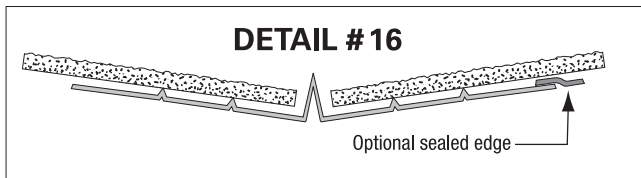

Valley flashing material must be minimum No. 26 gauge corrosion-resistant steel or better. Copper flashing should be considered for highly corrosive environments.

When using counterbattens or EBS the battens should extend to the second rib of the valley metal in order to support the tile in the valley (see detail #16a).

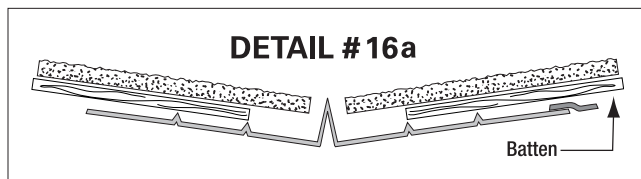

**SIDE WALL TREATMENT:**

For new construction, prepare flashing as prescribed in the TRI/WSRCA Installation Guide. For reroof situations where existing counter flashing may not allow conventional procedures, refer to the following guidelines.

The underlayment shall have a minimum 1" upward fold and be tucked at least 4" under the existing flashing. The edge of the flashing shall be sealed with a bead of mastic and secured to the roof deck at least every 24" on center. A rolled-hem pan flashing should be sealed to wall prior to nailing every 24". DO NOT PUNCTURE THE PAN PORTION OF THE FLASHING WHEN INSTALLING THE FLASHING OR THE TILE (see detail #17).

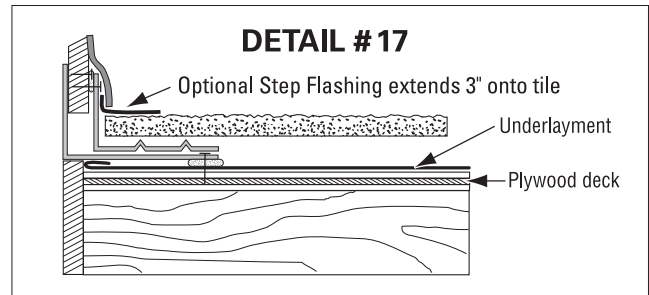

In areas of high rainfall or debris accumulation, the edge of the flashing should be three-coursed or an approved peel-and-stick membrane sealed to the roof underlayment. Step shingles are applied on top of each course and sealed to the wall with a bead of plastic cement.

**HEAD WALL TREATMENT:**

For new construction, prepare flashing as prescribed in the TRI/WSRCA Installation Guide. For reroof situations where existing counter flashing may not allow conventional procedures, refer to the following guidelines.

The underlayment shall have a minimum 1" upward fold and be tucked at least 4" under the existing flashing or shall extend up the wall at least 6". The tile is then fastened to roof deck. The horizontal flashing shall be 4" on the wall and 4" on the shakes with the break 5° less than the existing roof. The headwall flashing is set 1" above the plane of the roof deck.

NOTE: If the tile cannot be fastened directly to the deck, it must be secured to the head of the lower course with an approved concrete adhesive. Follow good roofing practice to ensure all water is directed on top of tile.

## HIP AND RIDGE TREATMENT:

The underlayment shall lap the hip and ridge a minimum of 6" on each side, effectively providing a minimum double layer of underlayment. Adequately fasten optional nailer board along the hip and ridge with corrosion-resistant fasteners.

Tile is laid and cut to fit against nailer board on the hips, and laid to within 1/2" average of the nailer board.

The first hip piece may be boosted by a cut piece of trim tile, mortar or other approved methods. The ridge and hip should be installed with a minimum 2" headlap. Each trim piece is applied with one corrosion-resistant fastener long enough to penetrate 3/4" into the nailer board and plastic cement under the nose of the piece to cover the nail head and form a bond between the tiles (see detail #18).

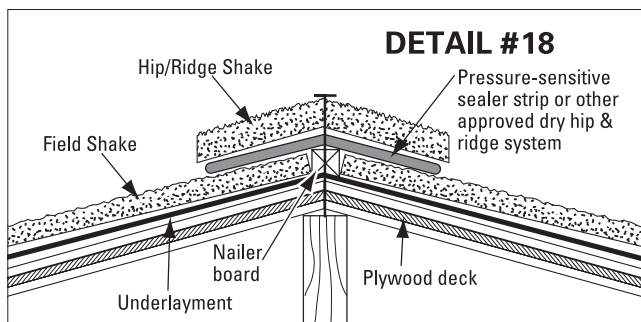

**NOTE:** For steeper roofs it is recommended to consider use of the 90 degree rake tile instead of the ridge tile to help create a better fit.

## In Areas of Extreme Freezing, Snow or Cold:

Standard weight tiles such as Madera 900 should be used for these areas.

## High Wind:

High wind applications of Madera 900 should be installed in accordance with TRI Installation Guide, Table 1A.

## Replacing Broken Cedarlite® 600 or Madera 700/900:

Remove the broken piece and fasteners and patch the resulting hole in the underlayment. Gently lever up the left piece. Slide the new piece in place and fasten with approved adhesive. Refer to the TRI/WSRCA Installation Guide, Detail MC-24A.

## SPECIAL INSTRUCTIONS:

EACH DAY DURING INSTALLATION THE ROOF SHOULD BE SWEEPED AND WASHED TO REMOVE CEMENT DUST AND DEBRIS WHICH CAN DISCOLOR THE TILE. UNLESS OTHERWISE SHOWN, ALL METHODS OF APPLICATION SHALL COMPLY WITH TRI/WSRCA INSTALLATION MANUAL, ICC ESR 2015P AND CHAPTER 15 OF THE IBC.

## IMPORTANT NOTICE

Newpoint™ will issue publications containing recommendations for the installation of its products from time to time. These are recommendations for the proper installation of Cedarlite® 600 and Madera 700/900.

It is important to recognize that these recommendations are neither warranties, express or implied, nor representative of the only method by which Newpoint™ concrete tile products may be properly installed. Rather, they try to summarize for the designer, applicator or developer good roofing practice and some of the industry standards for the installation of concrete roofing tile which have been developed over a period of time from actual trade practice and the requirements of various building code agencies. Notwithstanding, Newpoint™ wants to stress that it is neither familiar with all local building codes as these pertain to the installation of its products nor the local weather conditions. Equally, Newpoint™ neither installs tile itself nor has any control over its installation. Consequently, the general contractor, the roofing contractor and/or installer, and the homeowner must accept the responsibility for ensuring that Cedarlite® 600 and Madera 700/900 are installed in accordance with all applicable building and roofing installation codes and good roofing practice.

When they are new, Cedarlite® 600 and Madera 700/900 tiles have a visible shine on the surface that is due to an acrylic sealer that is applied to the tile during manufacture. This sealer is applied to all concrete tiles to help prevent efflorescence from occurring as the tiles are subjected to periods of wetting and drying. Since efflorescence is only a temporary condition and the likelihood of reoccurrence diminishes with age, the sealer and shiny surface will slowly break down and wear away exposing the natural surface and color of the tile. While this process usually occurs very gradually, visible as only a slight lightening of the appearance, occasionally climate conditions are such that the sealer will exhibit patches of white that is often mistaken as efflorescence. While this condition can be unsightly, it does not affect the integrity of the tile and it will gradually go away. How long this process lasts can vary depending on climate conditions, roof slope and exposure but normally it will be completely gone within the first five years. After this initial appearance change, it will not reoccur and the color-through tiles will then maintain an even color for the life of the roof.

Newpoint™ does not and cannot warrant any method of installation of Cedarlite® 600 and Madera 700/900 and this installation guide includes only recommended installation methods.

Questions or suggestions regarding installation should be directed to 800.669.TILE (8453).

Changes, additions and/or deletions to this guide should be submitted to:

Westlake Royal Roofing Solutions  
7575 Irvine Center Drive, #100  
Irvine, CA 92618



# NEWPOINT™

CONCRETE ROOF TILE

## ABOUT WESTLAKE ROYAL ROOFING SOLUTIONS™

Westlake Royal Roofing Solutions™ is the combination of DaVinci® Roofscapes and the former Boral North America roofing product lines. The company is a recognized, national leader in durable and sustainable clay, composite, concrete, and steel roof systems and components. The company's offerings include US Tile® products, a legacy line of premium, stunning clay tile solutions manufactured to the highest standard of sustainability and craftsmanship: DaVinci® Roofscapes, beautiful and durable composite slate and shake roofing tiles; Newpoint™ Concrete Tile Roofing, the enduring line of concrete tile known for its superior strength, Class A fire rating and long-lasting beauty; Unified Steel™ Stone Coated Roofing, the ultra-lightweight roofing system which benefits from the structural strength of steel; and Westlake Royal™ Roofing Components, a full line of integrated roof components designed to deliver a higher standard of roof installation and performance.

## ABOUT WESTLAKE ROYAL BUILDING PRODUCTS™

Westlake Royal Building Products USA Inc., a Westlake company (NYSE:WLK), is a leader throughout North America in the innovation, design, and production of a broad and diverse range of exterior and interior building products, including Siding and Accessories, Trim and Mouldings, Roofing, Stone, Windows and Outdoor Living. For more than 50 years, Westlake Royal Building Products has manufactured high quality, low maintenance products to meet the specifications and needs of building professionals, homeowners, architects, engineers and distributors, while providing stunning curb appeal with an unmatched array of colors, styles, and accessories.

For more information, please visit [WestlakeRoyalBuildingProducts.com](http://WestlakeRoyalBuildingProducts.com). Follow us on LinkedIn and Instagram and “Like” us on Facebook.

### Sales Offices

**Phoenix**, ARIZONA  
**Corona**, CALIFORNIA  
**Lathrop**, CALIFORNIA  
**Stockton**, CALIFORNIA  
**Rialto**, CALIFORNIA  
**Denver**, COLORADO  
**Pompano Beach**, FLORIDA

**Lake Wales**, FLORIDA  
**Okeechobee**, FLORIDA  
**Atlanta**, GEORGIA  
**Henderson**, NEVADA  
**Fort Worth**, TEXAS  
**Katy**, TEXAS

### Corporate Office

**Westlake Royal Building Products**  
2801 Post Oak, Suite 600  
Houston, Texas 77056

### Western Office

**Westlake Royal Roofing Solutions**  
7575 Irvine Center Drive, Ste. #100  
Irvine, CA 92618

### Customer Service

800.669.TILE (8453)

### Website



[WestlakeRoyalRoofing.com](http://WestlakeRoyalRoofing.com)



**Westlake**  
Royal Roofing Solutions™