

**PERFORMANCE TEST REPORT**

**Rendered to:**

**GLASSCRAFT DOOR COMPANY**

**SERIES/MODEL: Buffalo Forge Steel Doors/Round Top Double**

**PRODUCT TYPE: In-swing Round Top Double Door LH-4-5/8**

| <b>Title</b>                          | <b>Summary of Results</b> |
|---------------------------------------|---------------------------|
| Uniform Load Deflection Test Pressure | +2427 Pa (+50.68 psf)     |
| Uniform Load Deflection Test Pressure | -3063 Pa (-63.98 psf)     |
| Uniform Load Structural Test Pressure | +3640 Pa (+76.02 psf)     |
| Uniform Load Structural Test Pressure | -4595 Pa (-95.97 psf)     |

This report contains in its entirety:

Cover Page: 1 page  
Report Body: 6 pages  
Drawings: 6 pages

Secure Electronic Seal  
for Electronic Submittal

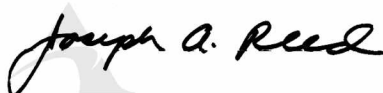
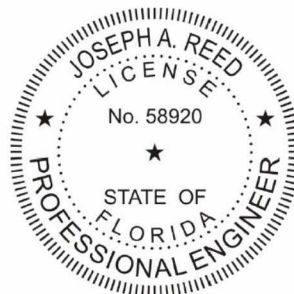

Digitally Signed by: Joseph A. Reed

Date: 2010.07.21 10:27:32 -04'00'

Reference should be made to Report No. 72618.01-801-44 for complete test specimen description and data.

## PERFORMANCE TEST REPORT

Rendered to:

GLASSCRAFT DOOR COMPANY  
2002 Brittmoore Road  
Houston, Texas 77043

Report No.: 72618.01-801-44

Revision 1: 07/21/10

Test Date: 04/17/07

Report Date: 06/18/07

\*\*Record Retention End Date: 04/17/11

**Project Summary:** Architectural Testing, Inc. was contracted by GlassCraft Door Company to perform testing on a Series/Model Buffalo Forge Steel Doors / Round Top Double, in-swing round top double door LH-4-5/8. Test specimen description and results are reported herein. The sample was provided by the client. Testing was conducted at the Architectural Testing, Inc. laboratory in Southlake, Texas.

**Test Method:** The test specimen was evaluated in accordance with:

*ASTM E 330-02, Test Method for Structural Performance of Exterior Windows, Curtain Walls and Doors by Uniform Static Air Pressure Difference*

### **Test Specimen Description:**

**Series/Model:** Buffalo Forge Steel Doors/ Round Top Double

**Product Type:** In-swing Round Top Double Door

**Overall Size:** 1902 mm (74-7/8") wide by 2508 mm (98-3/4") high

**Leaf Size (2):** 914 mm (36") wide by 2438 mm (96") high

**Door Daylight Opening Size (2):** 572 mm (22-1/2") wide by 2184 mm (86") high

**Overall Area:** 4.37 m<sup>2</sup> (47.04 ft<sup>2</sup>)

**Finish:** Brown paint

**Test Specimen Description:** (Continued)

**Glazing Details:** The insulating glass unit was exterior glazed. It was comprised of two pieces of 1/8" thick tempered pattern glass with a 1/4" air spacer providing 5/8" overall thickness. Butyl tape was located at the exterior and interior with a screw applied steel glazing bead at the interior. Glazing bead screws were located 7" from each corner and 10" on center thereafter.

**Weatherstripping:**

| <u>Description</u>              | <u>Quantity</u> | <u>Location</u>         |
|---------------------------------|-----------------|-------------------------|
| Foam filled vinyl leaf          | 1Row            | Jambs and head          |
| Adhesive back foam 1/2" by 1/4" | 1 Row           | Perimeter of vent frame |

**Frame Construction:** The door frame section was constructed of 4-5/8" thick steel jambs, and included an adjustable extruded aluminum threshold. The aluminum threshold was secured to the jambs with three #8 x 3" screws at each end.

**Leaf Construction:** The door leaf was constructed from steel with a foam core. A glass frame was secured to the door leaf with three barrel hinges and three sweep latches. Sweep latch keepers were welded to the door leaf. A decorative iron grille was secured at the exterior of the unit.

**Hardware:**

| <u>Description</u> | <u>Quantity</u> | <u>Location</u>  |
|--------------------|-----------------|--|
| Prodeco hinge      | 4               | 13" and 55" from the bottom of each leaf               |
| Glass frame hinge  | 6               | 12" from each end and the midpoint of each glass frame |
| Lockset            | 1               | 37" from the bottom of the lock stile                  |
| Deadbolt           | 1               | 43" from the bottom of the lock stile                  |
| Flush bolt         | 2               | Top and bottom of the fixed leaf                       |
| Sweep latch        | 6               | 12" from each end and the midpoint of the glass frame  |
| Sweep latch keeper | 6               | Door leaf corresponding to each sweep latch            |

**Test Specimen Description:** (Continued)

**Drainage:** Sloped sill

**Installation:** The jambs were secured to a #2 Yellow Pine test buck with #14 x 3" screws 9" from each corner and 16" on center thereafter.

**Test Results:** The following results have been recorded:

| <u>Test Method</u> | <u>Title of Test</u>  | <u>Indicator Readings (inch)</u> |           |           |
|--------------------|---|----------------------------------|-----------|-----------|
|                    |   | <u>#1</u>                        | <u>#2</u> | <u>#3</u> |
| ASTM E 330         | Uniform Load Deflection                                       |                                  |           |           |
|                    | (Deflections reported were taken on the active lock stile)    |                                  |           |           |
|                    | (Loads were held for 24 seconds)                              |                                  |           |           |
|                    | +2427 Pa (+50.68 psf) (positive)                              | 1.36                             | 0.90      | 0.95      |
|                    | -3063 Pa (-63.98 psf) (negative)                              | 0.15                             | 1.02      | 0.25      |
| ASTM E 330         | Uniform Load Structural                                       |                                  |           |           |
|                    | (Permanent sets reported were taken on the active lock stile) |                                  |           |           |
|                    | (Loads were held for 10 seconds)                              |                                  |           |           |
|                    | +3640 Pa (+76.02 psf) (positive)                              | 0.22                             | 0.22      | 0.23      |
|                    | -4595 Pa (-95.97 psf) (negative)                              | 0.19                             | 0.18      | 0.16      |

Tape and film were used to seal against air leakage during structural testing. In our opinion, the tape and film did not influence the results of the test.

**General Note:** Upon completion of testing, the specimens met the requirements of the referenced standards.

\*\*Detailed drawings, data sheets, representative samples of test specimens, a copy of this report, or other pertinent project documentation will be retained by Architectural Testing, Inc. for a period of four years from the original test date. At the end of this retention period, such materials shall be discarded without notice and the service life of this report will expire.

Results obtained are tested values and were secured by using the designated test methods. This report does not constitute certification of this product nor an opinion or endorsement by this laboratory. It is the exclusive property of the client so named herein and relates only to the specimen(s) tested. This report may not be reproduced, except in full, without the written approval of Architectural Testing, Inc.

For ARCHITECTURAL TESTING, INC:



Digitally Signed by: Andy Cost

---

Andy Cost  
Laboratory Manager



Digitally Signed by: Joseph A. Reed

---

Joseph A. Reed, P.E.  
Director – Engineering / Product Testing

AC:ay/cmd

Attachment (pages): This report is complete only when all attachments listed are included.  
Appendix-A: Drawings (6)

### Revision Log

| <u>Rev. #</u> | <u>Date</u> | <u>Page(s)</u> | <u>Revision(s)</u>   |
|---------------|-------------|----------------|--|
| 0             | 06/18/07    | N/A            | Original report issue  |
| 1             | 07/21/10    | 1, 5           | Replaced Expiration Date wording with Record Retention End Date. |

## **Appendix A**

### **Drawings**





Double door  
Full arch top

### list of material

- 1. Door Hardware/ Schlege F-series handle set with Dead Bolt F358ply620
- 2. Z-series sill (Endura
- 3. 98" Compression w/strip bronze



Architectural Testing

Test sample complies with these details.  
Deviations are noted.

Report# 72618.01-80144  
Date 6-12-07 Tech Ⓢ

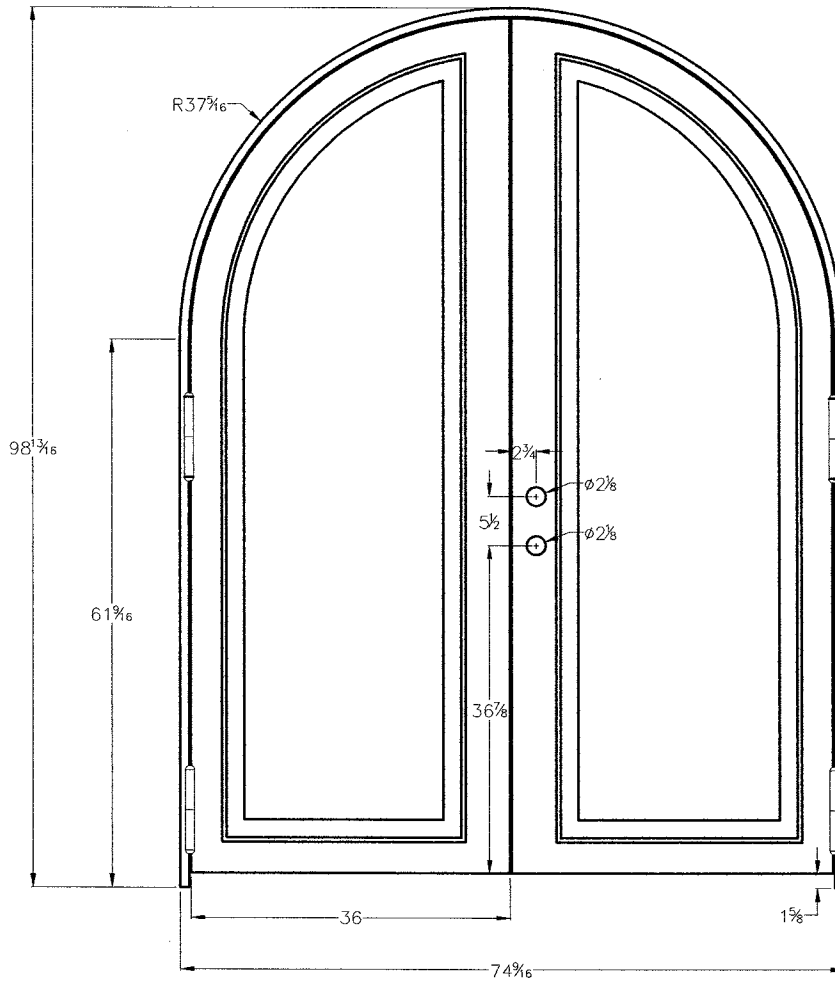

**Glass\*Craft**  
Door Company



Architectural Testing

Test sample complies with these details.  
Deviations are noted.

Report#

72618-01-801-44

Date 6-12-07

Tech

R

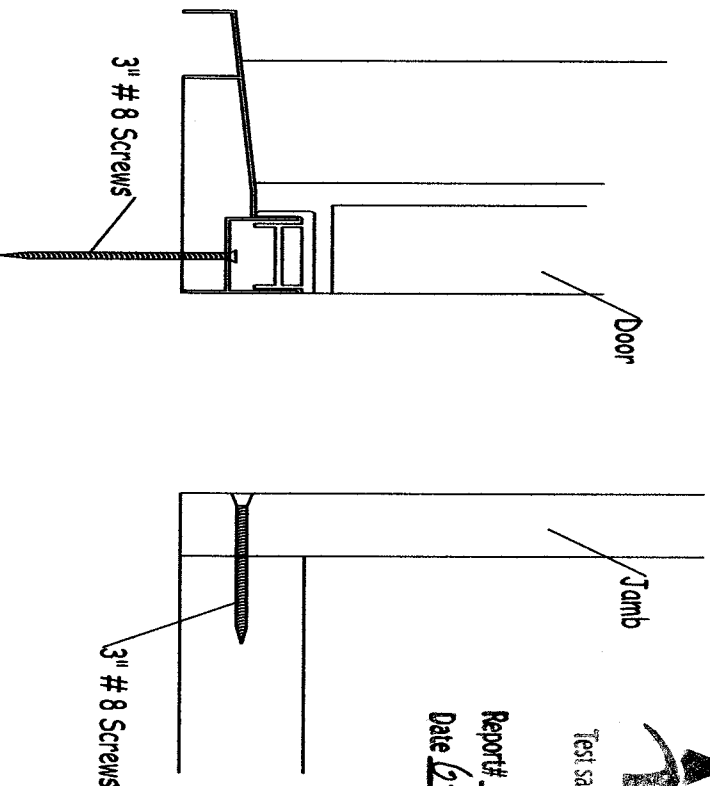

End Section View

Front View

Threshold In Swing

**Glass\*Craft**

Door Company

# Door Jam Cross Section



Architectural Testing

Test sample complies with these details.  
Deviations are noted.

Report# TAD18-01-801-44  
Date 6-12-07 Tech R

3" # 14 F/H Screws

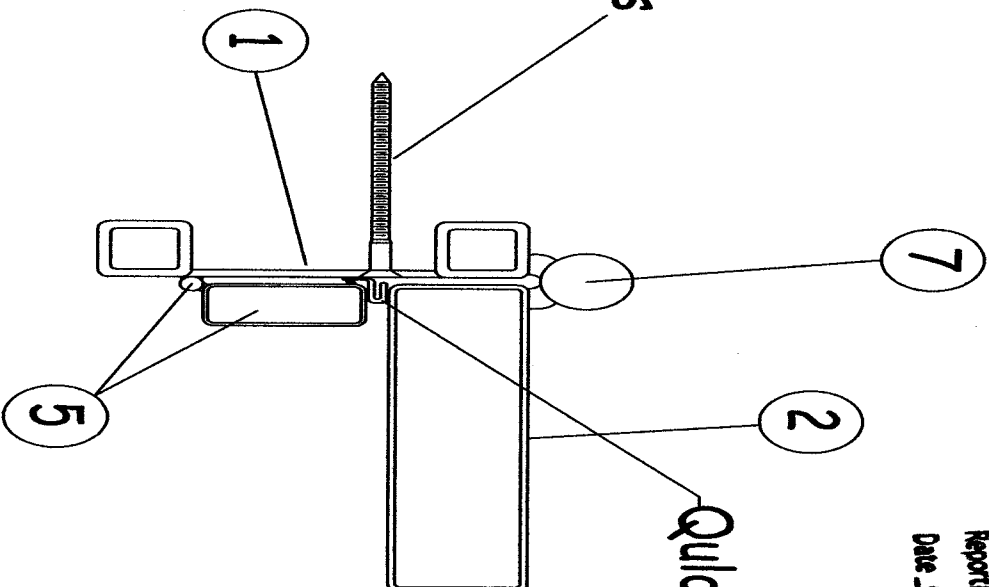

- 1 Jamb
- 2 Stile
- 3 Glass
- 4 Forge
- 5 Door stop
- 6 Astragal
- 7 Prodeco hinge
- 8 Glass frame hinge
- 9 Forge frame
- 10 Fixed glass stop
- 11 Screwed glass stop

**Glass\*Craft**  
Door Company

# Single door Cross Section

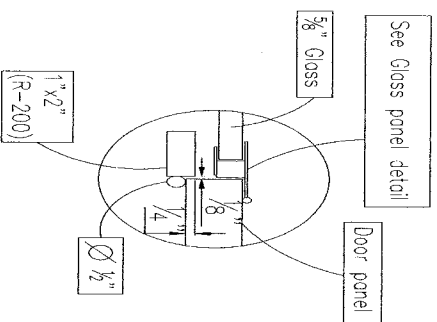
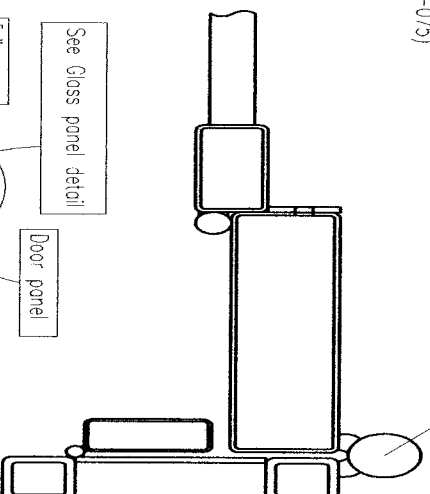
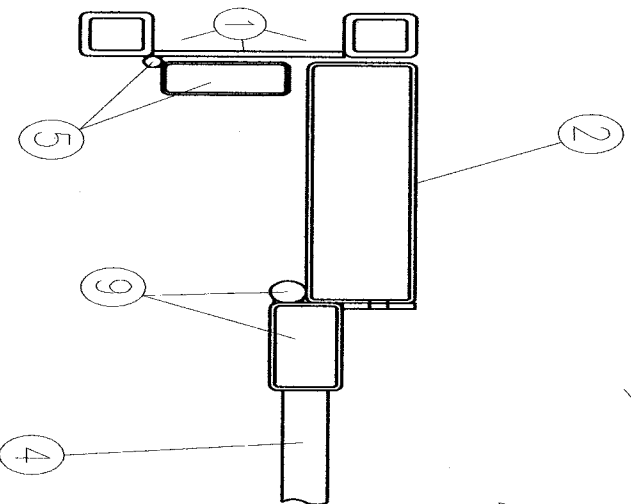
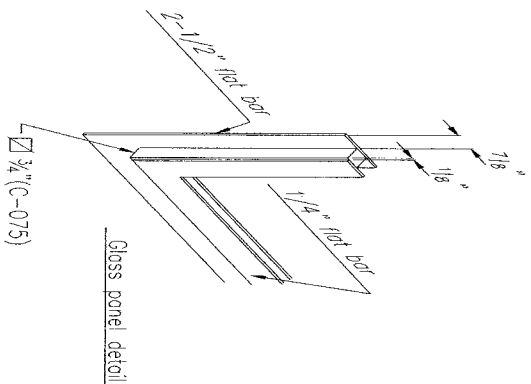

- 1 Lamb
- 2 Stile
- 3 Glass
- 4 Forge
- 5 Door stop
- 6 Astragal
- 7 Prodeco hinge
- 8 Glass frame hinge
- 9 Forge frame
- 10 Fixed glass stop
- 11 Screwed glass stop



Test sample complies with these details.  
Deviations are noted.

Report# 2861801501-44

Date 6-12-07 Tech [Signature]

**Glass\*Craft**  
Door Company



Test sample complies with these details.  
Deviations are noted.

Report# 72618.01-801-44

Date 6-12-07 Tech A

# Z/C FLUSH BOLT

**Product code: FB1**  
**Zinc alloy flush bolt with**  
**11" rod.**

- \*Positive "U" joint actuator with 7/8" throw
- \*1/8" offset with 3/4" backset.
- \*5/8" adjustment on rod length.
- \*Round brass tip
- \*Finish option:  
AL: Baked satin aluminum.  
DU: Baked duronodic.  
BK: Baked black.

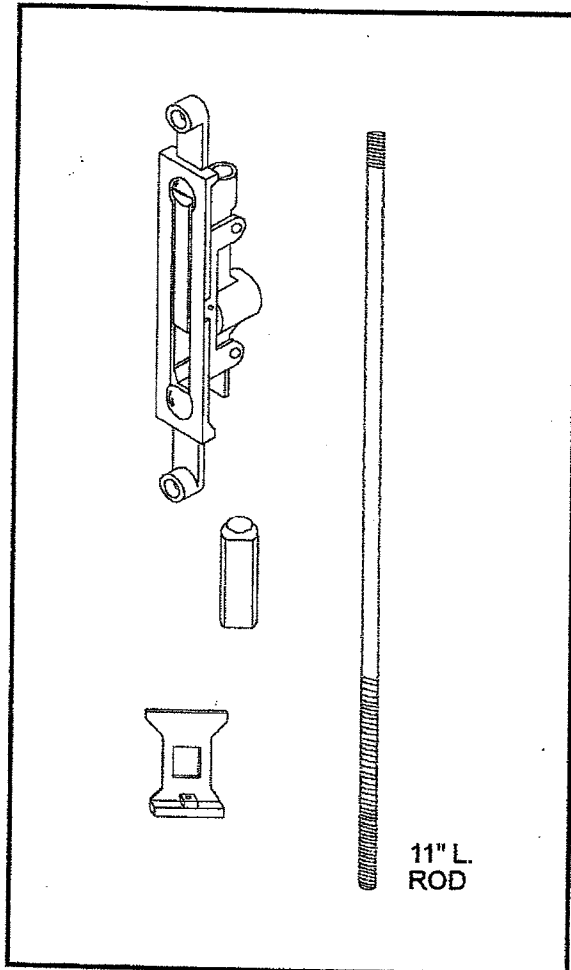

## Technical Information

