

# 3" PVC MULL BAR - LARGE MISSILE IMPACT

SHOWN w/DIFFERENT OPTIONS

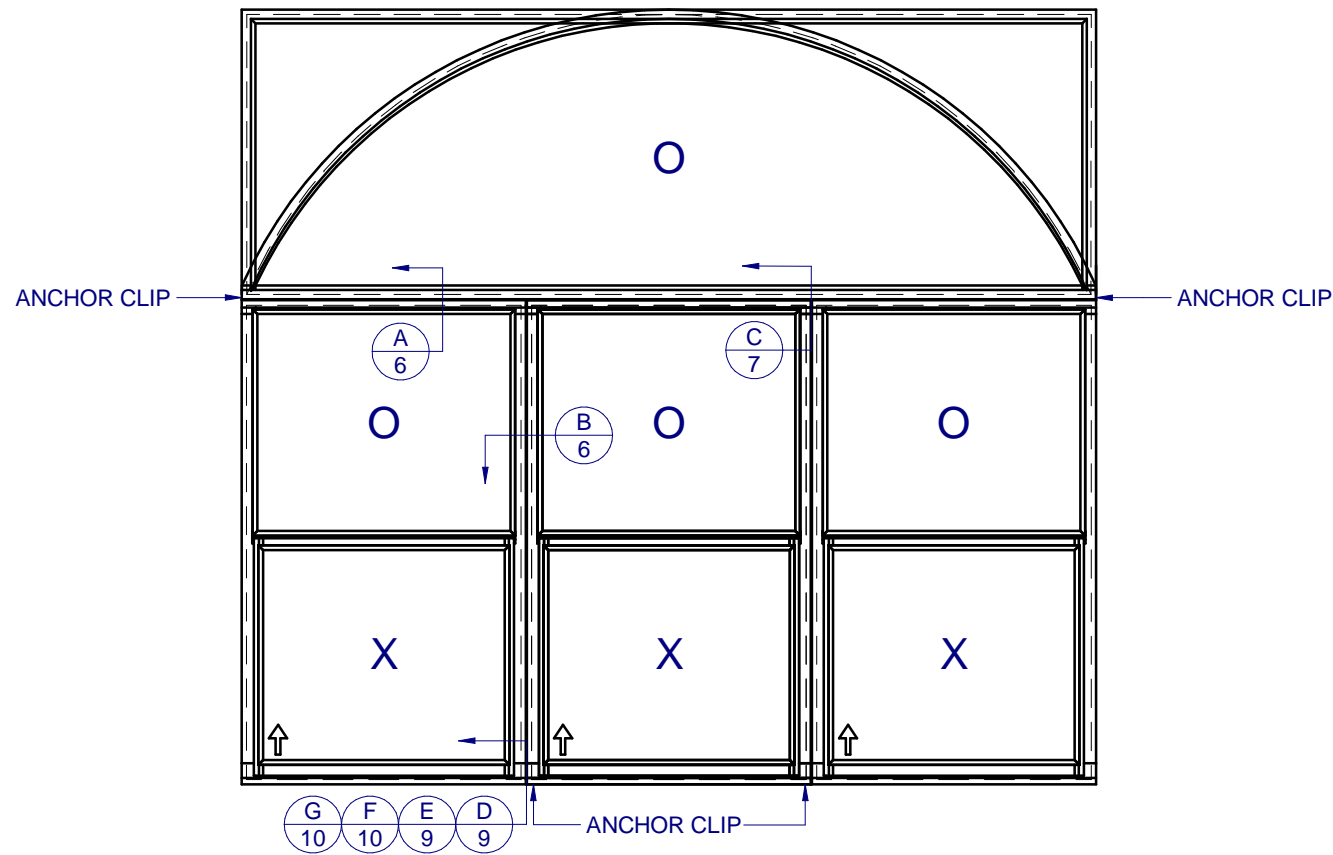

EXAMPLE HORIZ./VERT. MULLION FOR SECTION VIEW ONLY

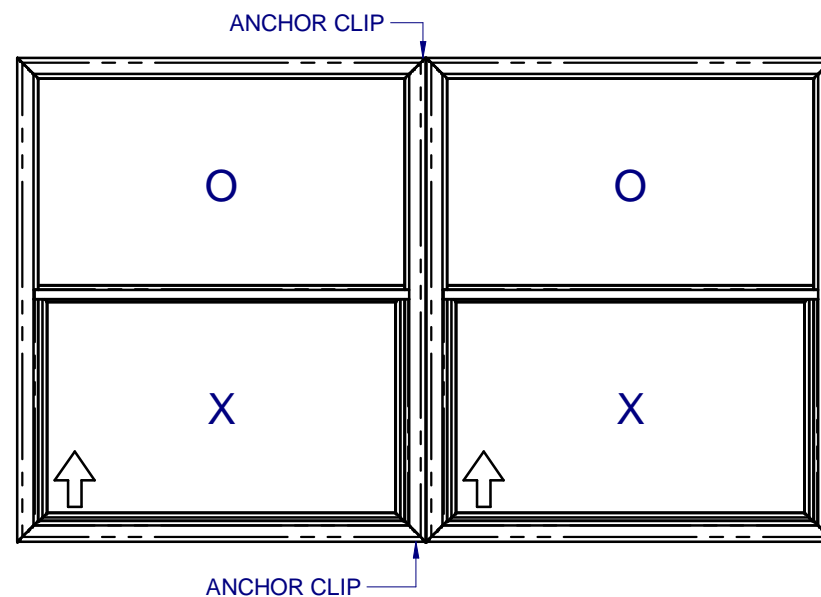

EXAMPLE VERTICAL MULLION FOR PVC WINDOWS FOR SECTION VIEWS ONLY

## TABLE OF CONTENTS

GENERAL NOTES & ELEVATIONS.....	1
DP CHARTS.....	2-3
BOM & EXTRUSIONS.....	4
EXTRUSIONS.....	5
SECTION VIEWS.....	6-7
CONFIGURATIONS & ANCHOR NOTES.....	8
INSTALLATION DETAILS.....	9-10

## GENERAL NOTES:

1. THE PRODUCT SHOWN HEREIN IS DESIGNED AND MANUFACTURED TO COMPLY WITH THE FLORIDA BUILDING CODE (FBC), CURRENT EDITION INCLUDING THE HIGH VELOCITY HURRICANE ZONE (HVHZ) AND IS RATED FOR WIND ZONE 4 MISSILE LEVEL D IMPACT USE AS DEFINED IN ASTM E 1996 PER THE FBC.
2. CONFIGURATIONS (SEE SHEETS 2-3): VERTICAL OR HORIZONTAL.
3. SEE MULLION CHARTS FOR MAX. DESIGN PRESSURES AND LENGTH. (REFER TO SHEETS 2-3)
4. ANCHORAGE: THE 33 1/3% STRESS INCREASE HAS NOT BEEN USED IN THE DESIGN OF THIS PRODUCT. SEE SHEETS 9-10 FOR ANCHOR DETAILS. WINDLOAD DURATION FACTOR Cd=1.6 WAS USED FOR WOOD ANCHOR CALCULATIONS.
5. PRODUCT APPROVED FOR IMPACT RESISTANCE. SHUTTERS ARE NOT REQUIRED.
6. DESIGN PRESSURE OF MULLED UNITS SHALL BE CONTROLLED BY THE LESSER DESIGN PRESSURE OF THE MULLION OR THE INDIVIDUAL WINDOW UNITS.
7. DESIGN PRESSURES AND INSTALLATION DETAILS SHOWN IN THIS DOCUMENT APPLY ONLY TO THE MULLION. WINDOWS MUST BE APPROVED UNDER SEPARATE APPROVAL.
8. RESPONSIBILITY OF SELECTING FENESTRATION PRODUCTS TO MEET ANY APPLICABLE LOCAL LAWS, BUILDING CODES, ORDINANCES OR OTHER SAFETY REQUIREMENTS RESTS SOLELY WITH THE ARCHITECT, ENGINEER OF RECORD, BUILDING OWNER OR CONTRACTOR.
9. SINGLE UNITS TO BE MULLED ARE NOT LIMITED TO THOSE SHOWN IN THIS DRAWING. SINGLE UNITS TO BE MULLED TOGETHER MUST BE MANUFACTURED BY CUSTOM WINDOW SYSTEMS, INC. AND MUST BE MADE OUT OF VINYL PVC OR EXTRUDED ALUMINUM.
10. VERTICAL MULLED UNITS MAY BE MULLED INDEFINITELY AS LONG AS THE SINGLE UNIT WIDTH AND HEIGHT ARE NOT EXCEEDED, AND MULLIONS ARE ANCHORED AS SHOWN HERE IN.
11. HORIZONTAL MULLION SHALL EXTEND THE ENTIRE WIDTH OF THE MULLED UNIT. VERTICAL MULLION IS USED TO MULL SIDE BY SIDE UNITS TOGETHER.



## 3" PVC MULL BAR IMPACT

PROPRIETARY AND CONFIDENTIAL  
 THE INFORMATION CONTAINED IN THIS DRAWING IS THE SOLE PROPERTY OF CUSTOM WINDOW SYSTEMS, INC. ANY REPRODUCTION IN PART OR AS A WHOLE WITHOUT THE WRITTEN PERMISSION OF CUSTOM WINDOW SYSTEMS, INC IS PROHIBITED.

FLORIDA APPROVAL NO.:  
9520



9/20/2023

LUCAS A. TURNER, P.E.  
 FL PE # 58201  
 Turner Engineering & Consulting, Inc.  
 2428 Old Natchez Trc Trl  
 Camden, TN 38320  
 PH. 941-380-1574

SHEET DESCRIPTION:

## GENERAL NOTES AND ELEVATIONS

DRAWN BY: MCS	DATE: 9/8/2023
DWG #: CWS-836	REV.: D
SCALE: 1:25	SHEET 1 OF 10

Design Pressure Chart (PSF) for NON-INTERSECTED Impact PVC 3" Mullion H-1758, with 1522 clips using four (4) #10 Screws into WOOD or METAL or 3/16" ITW Tapcons or DEWALT ULTRACON+ into SOLID CONCRETE or WOOD per each end of mullion. HOLLOW or GROUT-FILLED BLOCK require 1/4" DEWALT ULTRACON+.

		OPENING SIZE (in.)																	
		39	45	51	57	63	69	75 3/8	81	87	93	99	107 3/8	114	120	126	132	138	145 3/8
MULL LENGTH (in.)	37	80.0	80.0	80.0	80.0	80.0	80.0	80.0	80.0	80.0	80.0	80.0	80.0	80.0	80.0	80.0	80.0	80.0	80.0
	42 3/4	80.0	80.0	80.0	80.0	80.0	80.0	80.0	80.0	80.0	80.0	80.0	80.0	80.0	80.0	80.0	80.0	80.0	80.0
	48 3/4	80.0	80.0	80.0	80.0	80.0	80.0	80.0	80.0	80.0	80.0	80.0	80.0	80.0	80.0	80.0	80.0	80.0	65.0
	53 1/8	80.0	80.0	80.0	80.0	80.0	80.0	80.0	80.0	80.0	80.0	80.0	80.0	80.0	80.0	80.0	80.0	65.0	65.0
	57	80.0	80.0	80.0	80.0	80.0	80.0	80.0	80.0	80.0	80.0	80.0	80.0	80.0	80.0	65.0	65.0	65.0	
	63	80.0	80.0	80.0	80.0	80.0	80.0	80.0	80.0	80.0	78.9	76.6	74.8	72.5	65.0	65.0			
	65	65.0	65.0	65.0	65.0	65.0	65.0	65.0	65.0	65.0	65.0	65.0	65.0	65.0	65.0				
	68	65.0	65.0	65.0	65.0	65.0	65.0	65.0	65.0	65.0	65.0	65.0	65.0	65.0	63.5				
72	65.0	65.0	65.0	65.0	65.0	65.0	65.0	65.0	64.9	61.7	59.1	56.9	53.7						

DP CHART IS FOR:  
NON-INTERSECTED IMPACT 3" MULLION 1758, HORIZONTAL OR VERTICAL, USING (PER END):

- 1522 CLIPS
- (4) #10 SCREWS INTO WOOD or METAL
- (4) 3/16" ITW TAPCONS or DEWALT ULTRACON+ INTO SOLID CONCRETE or WOOD
- (4) 1/4" DEWALT ULTRACON+ INTO HOLLOW or GROUT-FILLED BLOCK

Design Pressure Chart (PSF) for NON-INTERSECTED Impact PVC 3" Mullion H-1758, with 1776 clips with six (6) #10 Screws into WOOD or METAL or 3/16" ITW Tapcons or DEWALT ULTRACON+ into SOLID CONCRETE or WOOD per each end of mullion. HOLLOW or GROUT-FILLED BLOCK require 1/4" DEWALT ULTRACON+.

		OPENING SIZE (in.)																	
		39	45	51	57	63	69	75 3/8	81	87	93	99	107 3/8	114	120	126	132	138	145 3/8
MULL LENGTH (in.)	37	80.0	80.0	80.0	80.0	80.0	80.0	80.0	80.0	80.0	80.0	80.0	80.0	80.0	80.0	80.0	80.0	80.0	80.0
	42 3/4	80.0	80.0	80.0	80.0	80.0	80.0	80.0	80.0	80.0	80.0	80.0	80.0	80.0	80.0	80.0	80.0	80.0	80.0
	48 3/4	80.0	80.0	80.0	80.0	80.0	80.0	80.0	80.0	80.0	80.0	80.0	80.0	80.0	80.0	80.0	80.0	80.0	65.0
	53 1/8	80.0	80.0	80.0	80.0	80.0	80.0	80.0	80.0	80.0	80.0	80.0	80.0	80.0	80.0	80.0	80.0	65.0	65.0
	57	80.0	80.0	80.0	80.0	80.0	80.0	80.0	80.0	80.0	80.0	80.0	80.0	80.0	80.0	65.0	65.0	65.0	
	63	80.0	80.0	80.0	80.0	80.0	80.0	80.0	80.0	80.0	80.0	80.0	80.0	80.0	65.0	65.0			
	65	65.0	65.0	65.0	65.0	65.0	65.0	65.0	65.0	65.0	65.0	65.0	65.0	65.0	65.0				
	68	65.0	65.0	65.0	65.0	65.0	65.0	65.0	65.0	65.0	65.0	65.0	65.0	65.0	65.0				
72	65.0	65.0	65.0	65.0	65.0	65.0	65.0	65.0	64.9	61.7	59.1	56.9	53.7						

DP CHART IS FOR:  
NON-INTERSECTED IMPACT 3" MULLION 1758, HORIZONTAL OR VERTICAL, USING (PER END):

- 1776 CLIPS
- (6) #10 SCREWS INTO WOOD or METAL
- (6) 3/16" ITW TAPCONS or DEWALT ULTRACON+ INTO SOLID CONCRETE or WOOD
- (6) 1/4" DEWALT ULTRACON+ INTO HOLLOW or GROUT-FILLED BLOCK

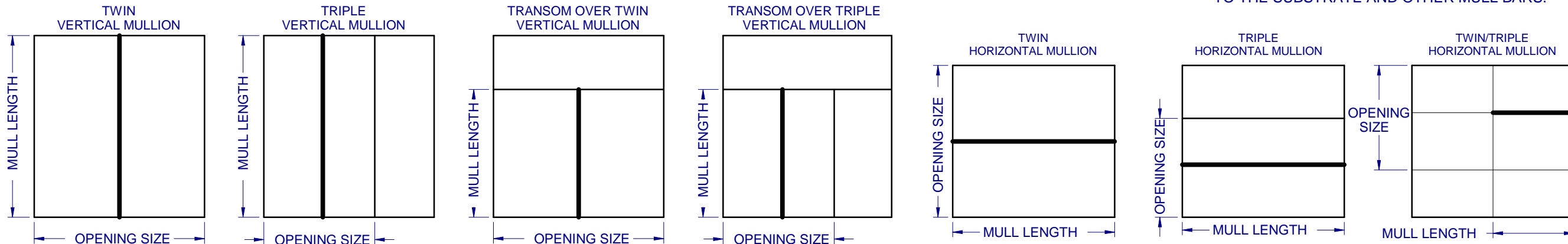

- NOTES:
1. THE MULL BAR IN FOCUS FOR ANY GIVEN CONFIGURATION IS SHOWN IN BOLD.
  2. AN INTERSECTED MULL BAR HAS OTHER MULL BAR(S) ATTACHED TO IT (SHOWN IN DASHES) THROUGH THE USE OF MULL BAR CLIPS. AN INTERSECTED MULL BAR WILL ALWAYS BE ATTACHED TO THE SUBSTRATE AT BOTH ENDS.
  3. NON-INTERSECTED MULL BARS CAN BE ATTACHED TO THE SUBSTRATE AND OTHER MULL BARS.



**3" PVC MULL BAR IMPACT**

PROPRIETARY AND CONFIDENTIAL  
THE INFORMATION CONTAINED IN THIS DRAWING IS THE SOLE PROPERTY OF CUSTOM WINDOW SYSTEMS, INC. ANY REPRODUCTION IN PART OR AS A WHOLE WITHOUT THE WRITTEN PERMISSION OF CUSTOM WINDOW SYSTEMS, INC IS PROHIBITED.

FLORIDA APPROVAL NO.:  
9520



9/20/2023

LUCAS A. TURNER, P.E.  
FL PE # 58201  
Turner Engineering & Consulting, Inc.  
2428 Old Natchez Trc Trl  
Camden, TN 38320  
PH. 941-380-1574

SHEET DESCRIPTION:  
DP CHARTS  
NON-INTERSECTED MULLS

DRAWN BY: MCS	DATE: 9/8/2023
DWG #: CWS-836	REV.: D
SCALE: 1:1	SHEET 2 OF 10

Design Pressure Chart (PSF) for INTERSECTED Impact PVC 3" Mullion H-1758, with 1522 clips using four (4) #10 Screws into WOOD or METAL or 3/16" ITW Tapcons into SOLID CONCRETE or WOOD, or 1776 clips with six (6) #10 Screws into WOOD or METAL or 3/16" ITW Tapcons into SOLID CONCRETE or WOOD per each end of mullion. HOLLOW or GROUT-FILLED BLOCK require 1/4" DEWALT ULTRACON+.

		OPENING SIZE (in.)																		
		39	45	51	57	63	69	75 3/8	81	87	93	99	110 3/8	114	120	126	132	138	145 3/8	
MULL LENGTH (in.)	37	50.0	50.0	50.0	50.0	50.0	50.0	50.0	50.0	50.0	50.0	50.0	50.0	50.0	50.0	50.0	50.0	50.0	50.0	50.0
	42 3/4	50.0	50.0	50.0	50.0	50.0	50.0	50.0	50.0	50.0	50.0	50.0	50.0	50.0	50.0	50.0	50.0	50.0	50.0	50.0
	48 3/4	50.0	50.0	50.0	50.0	50.0	50.0	50.0	50.0	50.0	50.0	50.0	50.0	50.0	50.0	50.0	50.0	50.0	50.0	50.0
	53 1/8	50.0	50.0	50.0	50.0	50.0	50.0	50.0	50.0	50.0	50.0	50.0	50.0	50.0	50.0	50.0	50.0	50.0	50.0	50.0
	57	50.0	50.0	50.0	50.0	50.0	50.0	50.0	50.0	50.0	50.0	50.0	50.0	50.0	50.0	50.0	50.0	50.0	50.0	48.1
	63	50.0	50.0	50.0	50.0	50.0	50.0	50.0	50.0	50.0	50.0	50.0	50.0	50.0	50.0	50.0	49.4	47.3		
	68	50.0	50.0	50.0	50.0	50.0	50.0	50.0	50.0	50.0	50.0	50.0	50.0	50.0	49.8	47.6				
	72	50.0	50.0	50.0	50.0	50.0	50.0	50.0	50.0	50.0	50.0	50.0	50.0	45.4	44.0					
75.375	50.0	50.0	50.0	50.0	50.0	50.0	50.0	50.0	50.0	50.0	46.8	44.0	40.0							

DP CHART IS FOR:  
INTERSECTED IMPACT 3" MULLION 1758, HORIZONTAL OR VERTICAL, USING EITHER (PER END):

- 1522 CLIPS  
 - (4) #10 SCREWS INTO WOOD or METAL  
 - (4) 3/16" ITW TAPCONS or DEWALT ULTRACON+ INTO SOLID CONCRETE or WOOD  
 - (4) 1/4" DEWALT ULTRACON+ INTO HOLLOW or GROUT-FILLED BLOCK
- 1767 CLIPS  
 - (6) #10 SCREWS INTO WOOD or METAL  
 - (6) 3/16" ITW TAPCONS or DEWALT ULTRACON+ INTO SOLID CONCRETE or WOOD  
 - (6) 1/4" DEWALT ULTRACON+ INTO HOLLOW or GROUT-FILLED BLOCK

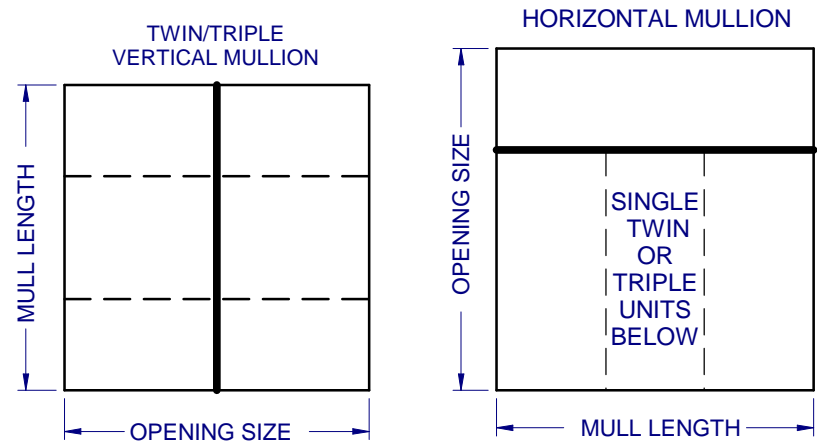

- NOTES:  
 1. THE MULL BAR IN FOCUS FOR ANY GIVEN CONFIGURATION IS SHOWN IN BOLD.  
 2. AN INTERSECTED MULL BAR HAS OTHER MULL BAR(S) ATTACHED TO IT (SHOWN IN DASHES) THROUGH THE USE OF MULL BAR CLIPS. AN INTERSECTED MULL BAR WILL ALWAYS BE ATTACHED TO THE SUBSTRATE AT BOTH ENDS.  
 3. NON-INTERSECTED MULL BARS CAN BE ATTACHED TO THE SUBSTRATE AND OTHER MULL BARS.

### 3" PVC MULL BAR IMPACT

PROPRIETARY AND CONFIDENTIAL  
 THE INFORMATION CONTAINED IN THIS DRAWING IS THE SOLE PROPERTY OF CUSTOM WINDOW SYSTEMS, INC. ANY REPRODUCTION IN PART OR AS A WHOLE WITHOUT THE WRITTEN PERMISSION OF CUSTOM WINDOW SYSTEMS, INC IS PROHIBITED.

FLORIDA APPROVAL NO.:  
9520

LUCAS A. TURNER  
 LICENSE  
 No. 58201  
 STATE OF FLORIDA  
 PROFESSIONAL ENGINEER  
 9/20/2023

LUCAS A. TURNER, P.E.  
 FL PE # 58201  
 Turner Engineering & Consulting, Inc.  
 2428 Old Natchez Trc Trl  
 Camden, TN 38320  
 PH. 941-380-1574

SHEET DESCRIPTION:  
**DP CHART INTERSECTED MULLS**

DRAWN BY: <b>MCS</b>	DATE: 9/8/2023
DWG #: <b>CWS-836</b>	REV.: D
SCALE: 1:1	SHEET 3 OF 10

ITEM	PART #	DESCRIPTION
1	H-1758	1 3/8" x 3" MULLION TUBE
2		#10 OR #12 HEX WASHER HEAD TEK SCREW *(see note below)
3		#10 x 1 1/2", PANHEAD PHILIPS ZINC
4		#10 FLAT WASHER
7	S-1897	MULLION CLIP, INTERSECTING
8		SEALANT
9	S-1895	DRIP CAP, HORZ, FLG
10	S-1896	FLANGE ADAPTER, VERT, FLG
11	S-6018	MULLION INTERIOR COVER, EXT, FIN/BOX
14	F-1522-013	3" SLOTTED NEW CONSTRUCTION FIN MULL CLIP
15	F-1522-006	3" SLOTTED T-CLIP, FLG/BOX
16	F-1767-001	L-ANGLE 3" MULL CLIP, STANDARD, FLG/BOX
17	F-1767-004L	L-ANGLE 3" MULL CLIP, FIN, LEFT
18	F-1767-004R	L-ANGLE 3" MULL CLIP, FIN, RIGHT
19		#10 HEX WASHER HEAD TEK SCREW
20		#10 FH TEK SCREW

LINE ITEMS NOT USED:  
5-6, 12

FRAME TYPE	OPENING	"T" MULLBAR CLIP (F-1522-XXX)	"L" MULLBAR CLIP (F-1767-XXX)
FLANGE	NEW	F-1522-013	F-1767-001
	RETRO	F-1522-006	F-1767-001
FIN	NEW	F-1522-013	F-1767-004(L&R)
	RETRO	F-1522-013	F-1767-004(L&R)
BOX	NEW	NOT RECOMMENDED	F-1767-001
	RETRO	F-1522-006	F-1767-001



1900 SW 44TH AVE.  
OCALA, FLORIDA 34474  
WWW.CWS.CC

### 3" PVC MULL BAR IMPACT

PROPRIETARY AND CONFIDENTIAL  
THE INFORMATION CONTAINED IN THIS DRAWING IS THE SOLE PROPERTY OF CUSTOM WINDOW SYSTEMS, INC. ANY REPRODUCTION IN PART OR AS A WHOLE WITHOUT THE WRITTEN PERMISSION OF CUSTOM WINDOW SYSTEMS, INC IS PROHIBITED.

FLORIDA APPROVAL NO.:  
9520



9/20/2023

LUCAS A. TURNER, P.E.  
FL PE # 58201  
Turner Engineering & Consulting, Inc.  
2428 Old Natchez Trc Trl  
Camden, TN 38320  
PH. 941-380-1574

SHEET DESCRIPTION:

### BOM AND EXTRUSIONS

DRAWN BY:	DATE:
MCS	9/8/2023
DWG #:	REV.:
CWS-836	D
SCALE:	SHEET
1:2	4 OF 10

\* USE WOOD SCREW SIZE (#10 OR #12), SPECIFIED IN WINDOW UNIT APPROVAL DOCUMENT

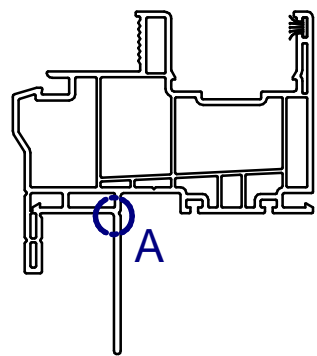
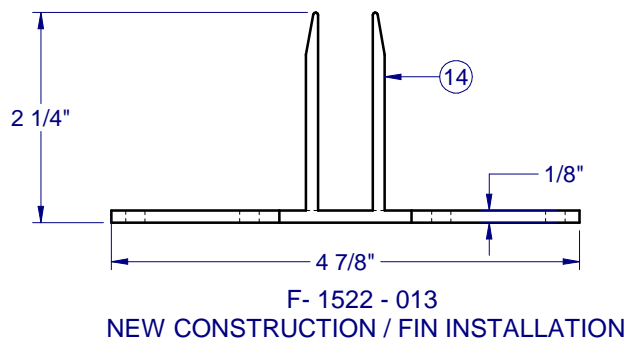
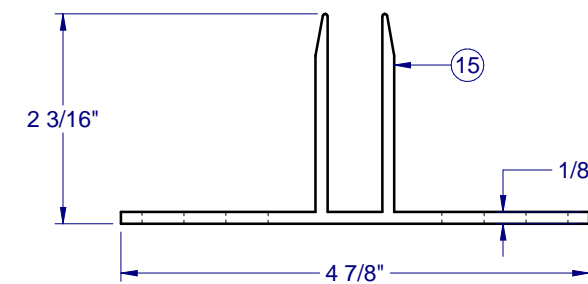
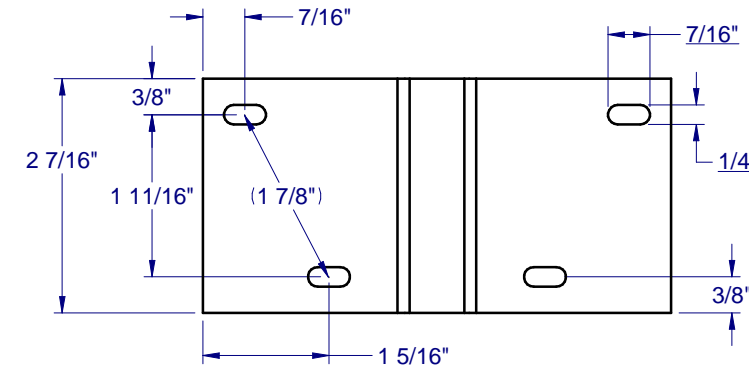
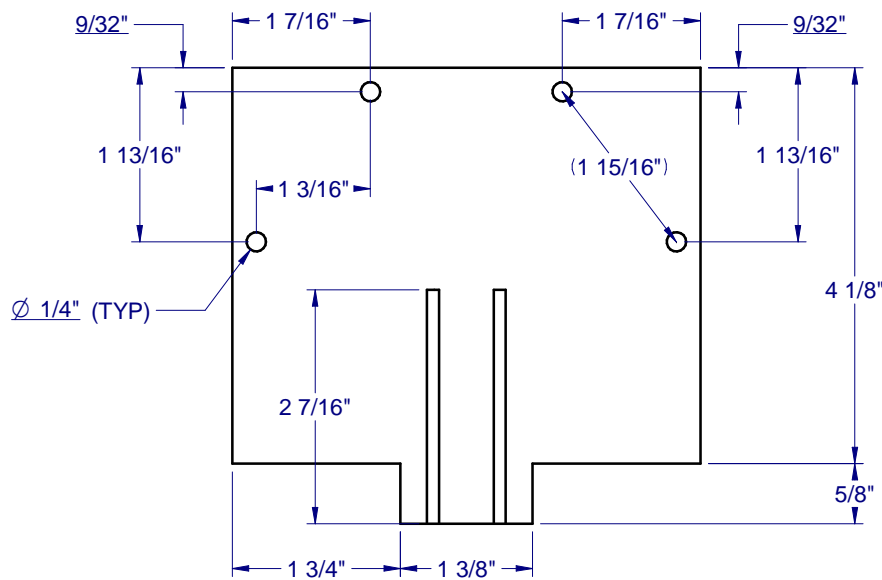
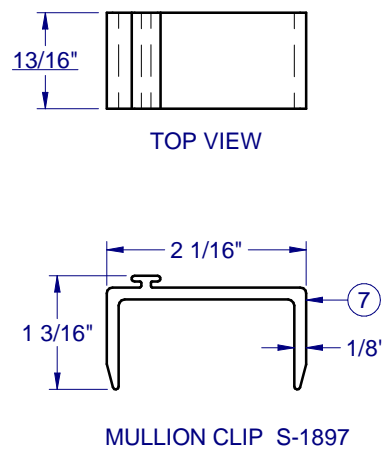
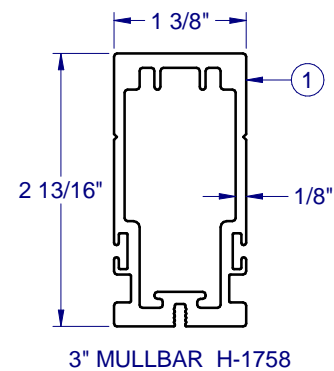
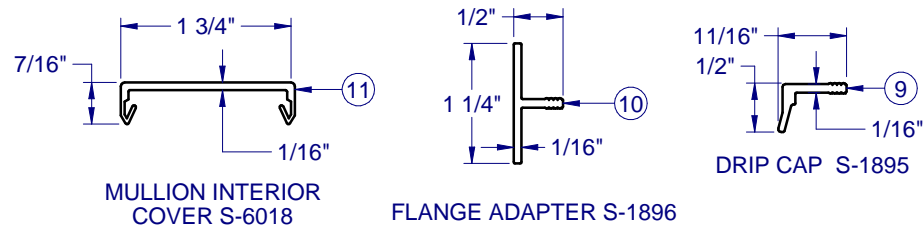

SCORE, BEND AND BREAK TO REMOVE FIN FOR FRAME ATTACHMENT TO MULL BAR



NOTE: ALL EXTRUSIONS ARE ALUMINUM 6063-T6 UNLESS OTHERWISE NOTED.

FRAME TYPE	OPENING	"T" MULLBAR CLIP (F-1522-XXX)	"L" MULLBAR CLIP (F-1767-XXX)
FLANGE	NEW	F-1522-013	F-1767-001
	RETRO	F-1522-006	F-1767-001
FIN	NEW	F-1522-013	F-1767-004(L&R)
	RETRO	F-1522-013	F-1767-004(L&R)
BOX	NEW	NOT RECOMMENDED	F-1767-001
	RETRO	F-1522-006	F-1767-001



1900 SW 44TH AVE.  
OCALA, FLORIDA 34474  
WWW.CWS.CC

### 3" PVC MULL BAR IMPACT

PROPRIETARY AND CONFIDENTIAL  
THE INFORMATION CONTAINED IN THIS DRAWING IS THE SOLE PROPERTY OF CUSTOM WINDOW SYSTEMS, INC. ANY REPRODUCTION IN PART OR AS A WHOLE WITHOUT THE WRITTEN PERMISSION OF CUSTOM WINDOW SYSTEMS, INC IS PROHIBITED.

FLORIDA APPROVAL NO.:  
9520

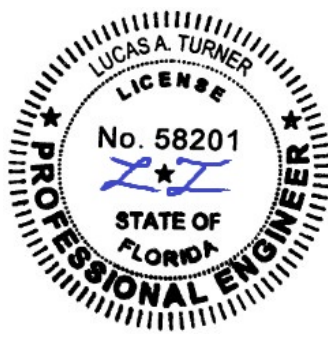

9/20/2023

LUCAS A. TURNER, P.E.  
FL PE # 58201  
Turner Engineering & Consulting, Inc.  
2428 Old Natchez Trc Trl  
Camden, TN 38320  
PH. 941-380-1574

SHEET DESCRIPTION:  
**EXTRUSIONS**

DRAWN BY: MCS	DATE: 9/8/2023
DWG #: CWS-836	REV.: D
SCALE: 1:2	SHEET 5 OF 10

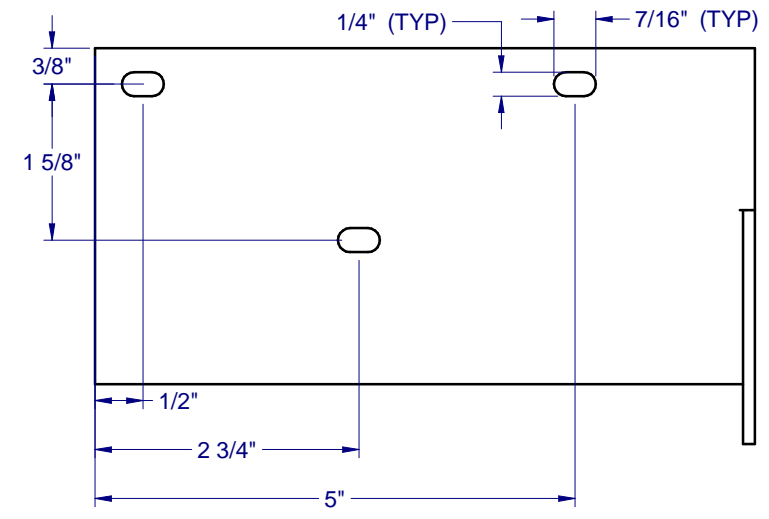
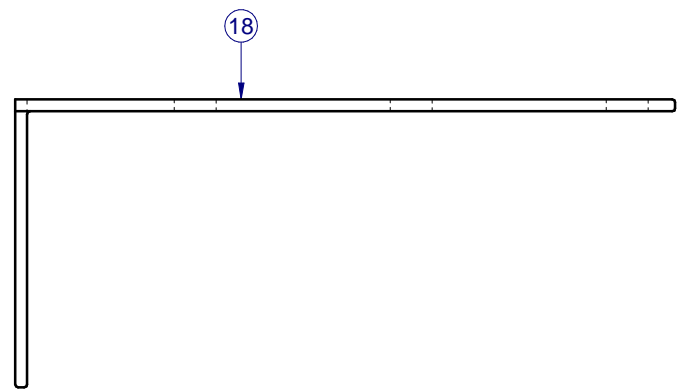
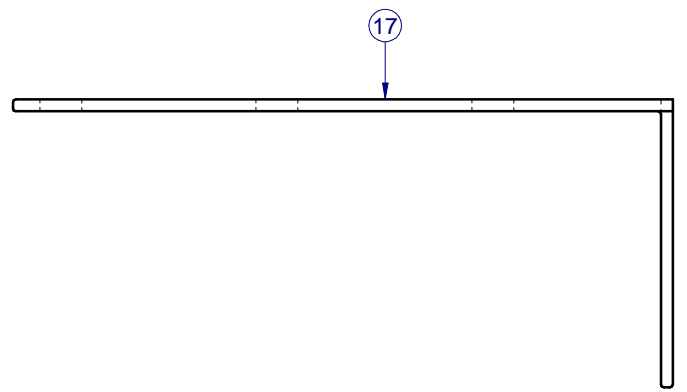

"L" ANGLE 3" MULL CLIP, FIN (LEFT) F-1767-004L

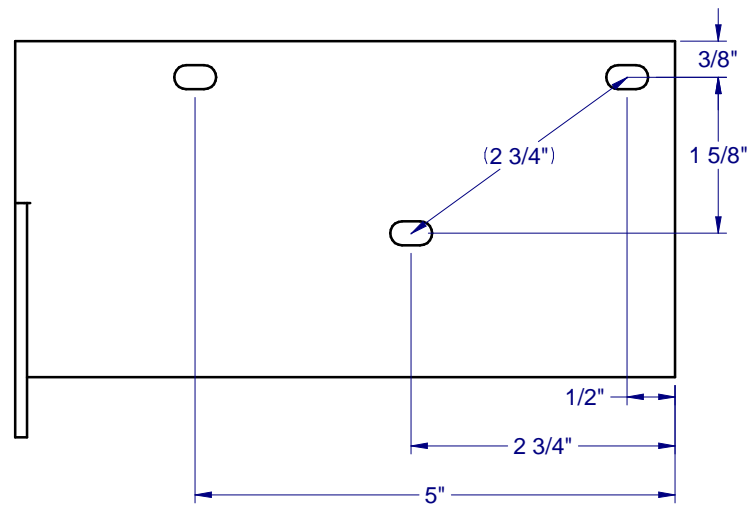

"L" ANGLE 3" MULL CLIP, FIN (RIGHT) F-1767-004R

OUTSIDE

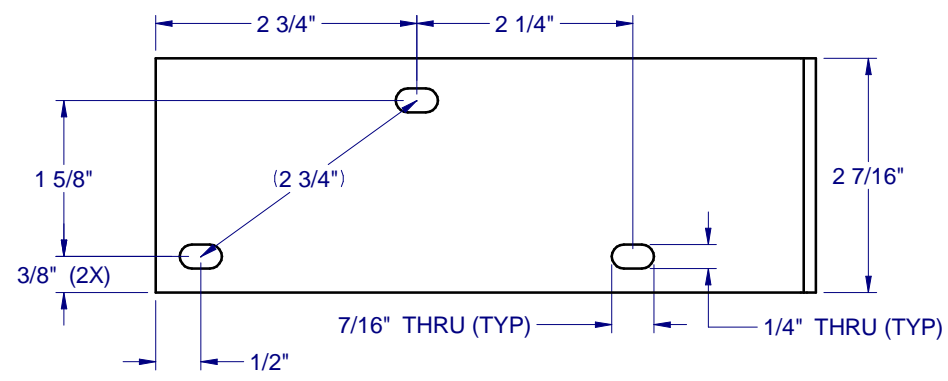

OUTSIDE

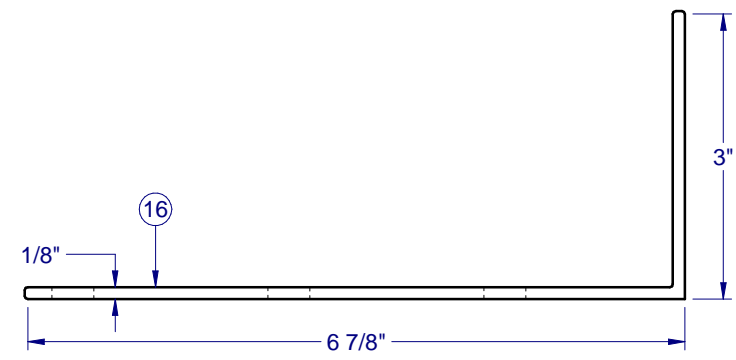

"L" ANGLE 3" STANDARD MULL CLIP - F-1767-001

**3" PVC  
MULL BAR  
IMPACT**

PROPRIETARY AND CONFIDENTIAL  
THE INFORMATION CONTAINED IN  
THIS DRAWING IS THE SOLE  
PROPERTY OF CUSTOM WINDOW  
SYSTEMS, INC. ANY  
REPRODUCTION IN PART OR AS A  
WHOLE WITHOUT THE WRITTEN  
PERMISSION OF CUSTOM WINDOW  
SYSTEMS, INC IS PROHIBITED.

FLORIDA APPROVAL NO.:

9520



9/20/2023

LUCAS A. TURNER, P.E.  
FL PE # 58201  
Turner Engineering &  
Consulting, Inc.  
2428 Old Natchez Trc Trl  
Camden, TN 38320  
PH. 941-380-1574

SHEET DESCRIPTION:

**SECTION VIEWS  
MULLS**

DRAWN BY:

MCS

DATE:

9/8/2023

DWG #:

CWS-836

REV.:

D

SCALE:

1:2

SHEET

6 OF 10

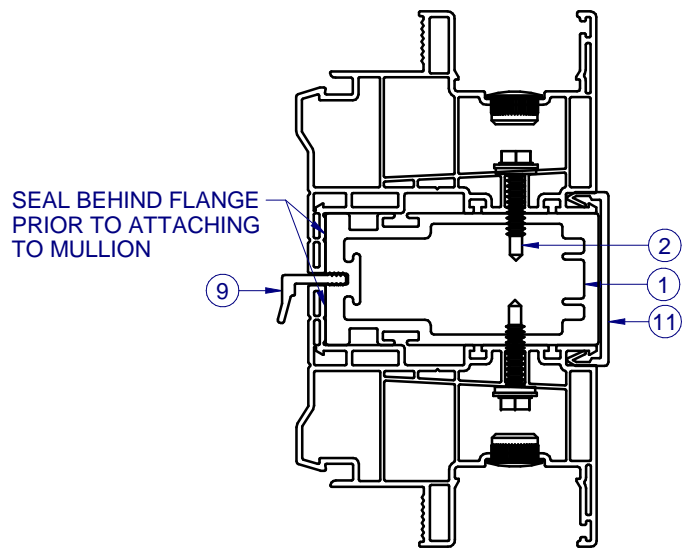

**A**  
**6** HORIZONTAL MULL BAR SECTION  
FLANGE FRAME WINDOW

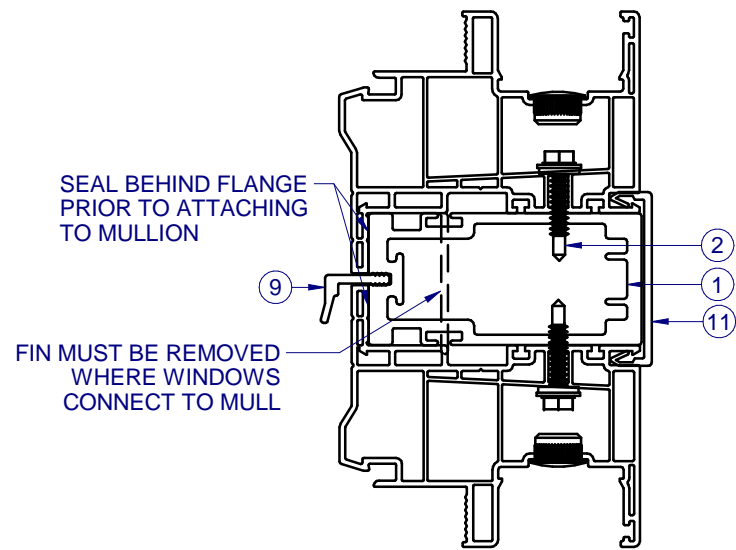

**A**  
**6** HORIZONTAL MULL BAR SECTION  
FIN FRAME WINDOW

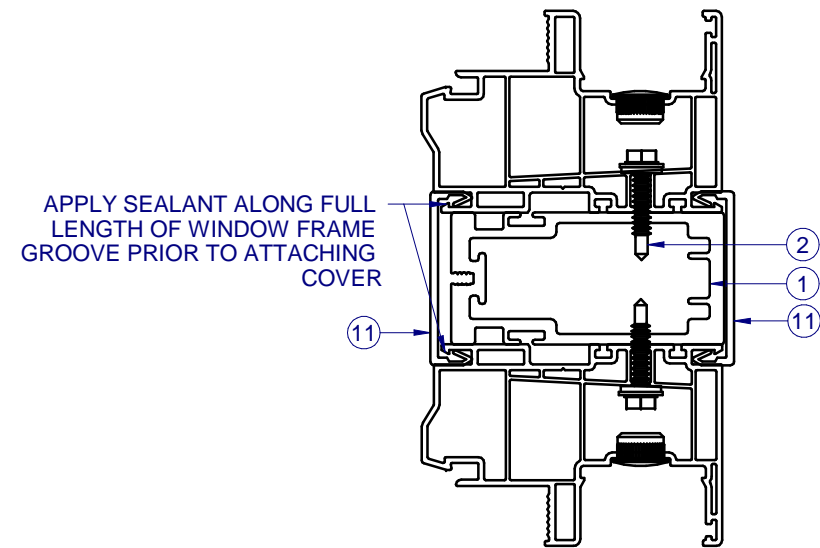

**A**  
**6** VERTICAL/HORIZONTAL MULL BAR SECTION  
BOX FRAME WINDOW

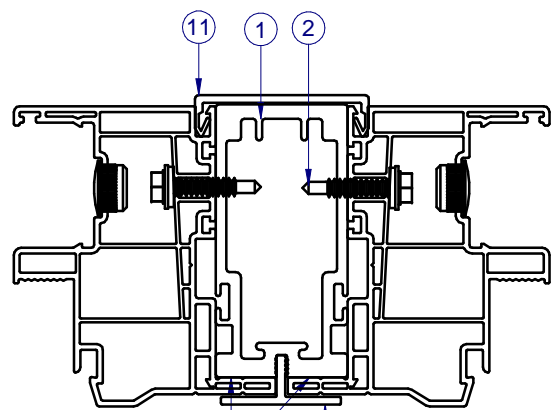

**B**  
**6** VERTICAL MULL BAR SECTION  
FLANGE FRAME WINDOW

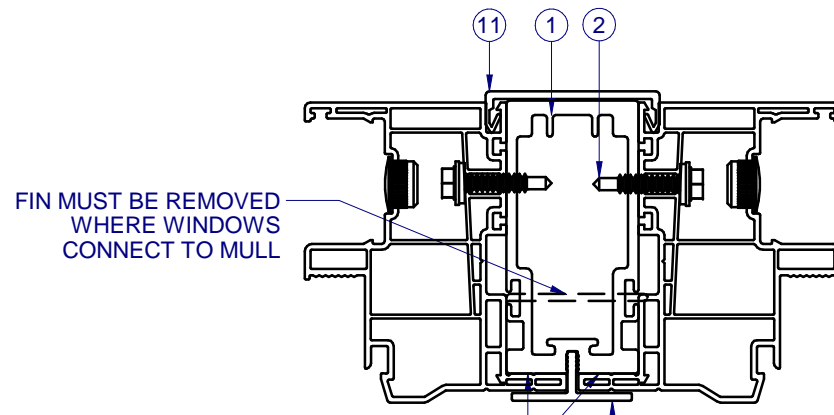

**B**  
**6** VERTICAL MULL BAR SECTION  
FIN FRAME WINDOW

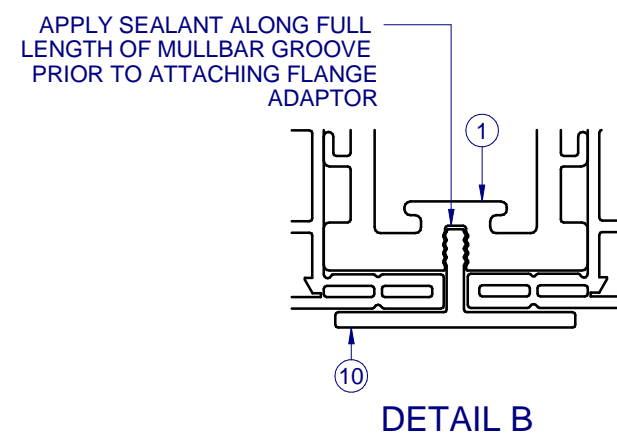
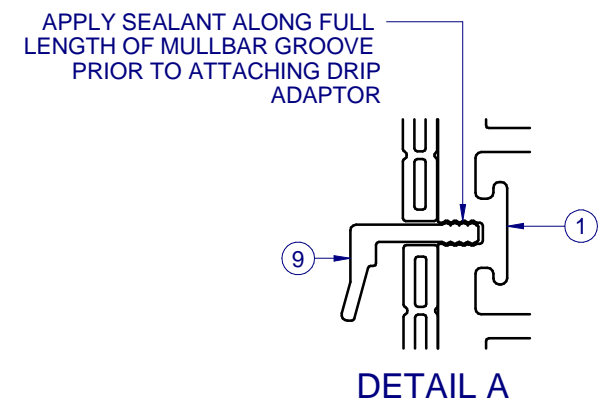



1900 SW 44TH AVE.  
OCALA, FLORIDA 34474  
WWW.CWS.CC

**3" PVC  
MULL BAR  
IMPACT**

**PROPRIETARY AND CONFIDENTIAL**  
THE INFORMATION CONTAINED IN THIS DRAWING IS THE SOLE PROPERTY OF CUSTOM WINDOW SYSTEMS, INC. ANY REPRODUCTION IN PART OR AS A WHOLE WITHOUT THE WRITTEN PERMISSION OF CUSTOM WINDOW SYSTEMS, INC IS PROHIBITED.

FLORIDA APPROVAL NO.:  
9520



9/20/2023

LUCAS A. TURNER, P.E.  
FL PE # 58201  
Turner Engineering & Consulting, Inc.  
2428 Old Natchez Trc Trl  
Camden, TN 38320  
PH. 941-380-1574

SHEET DESCRIPTION:

**SECTION VIEWS  
MULL INTERSECTIONS**

DRAWN BY:	DATE:
MCS	9/8/2023
DWG #:	REV.:
CWS-836	D
SCALE:	SHEET
1:2	7 OF 10

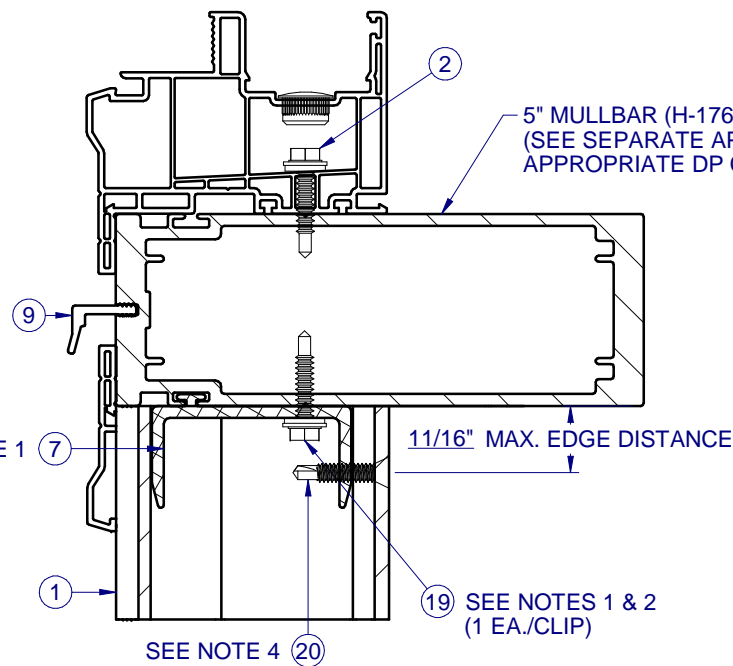
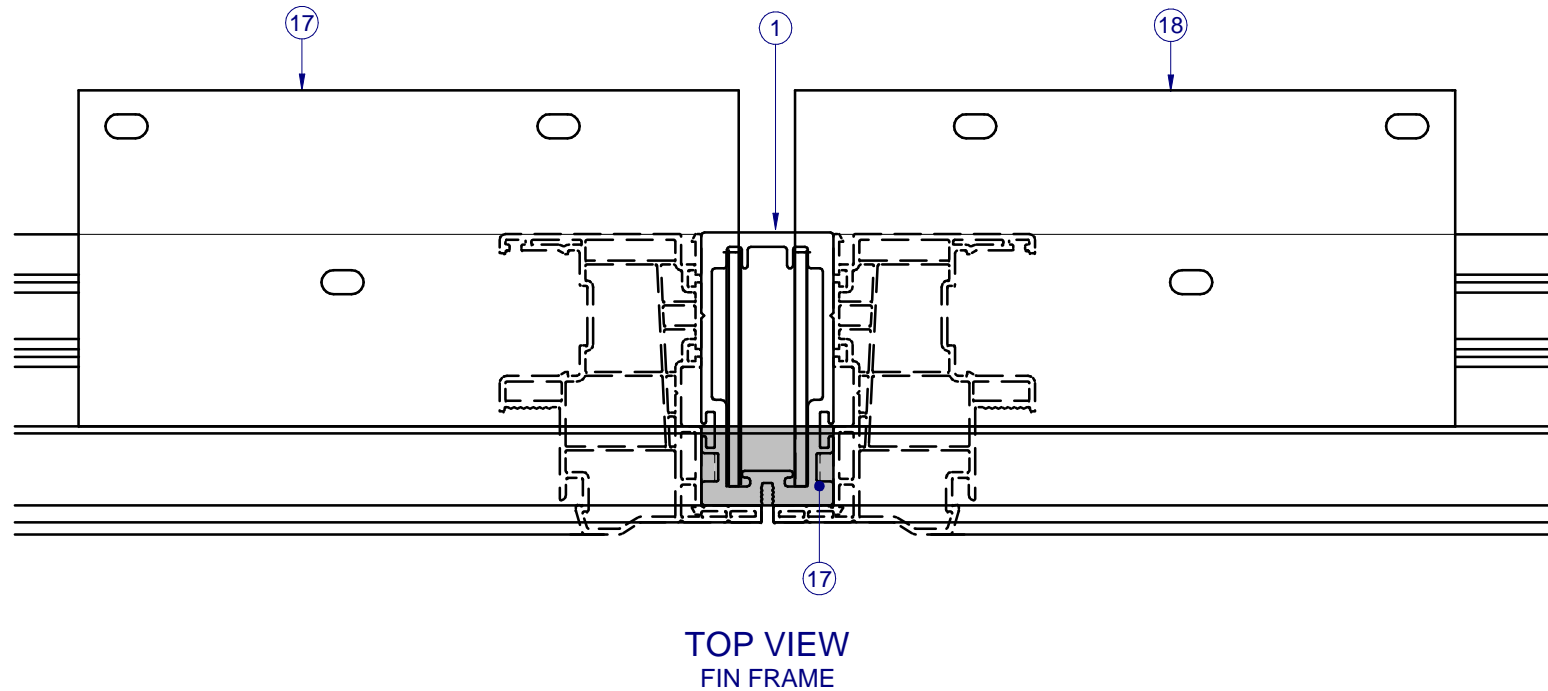

**C** 5" HORIZ. TO 3" VERT. MULLBAR SECTION  
**7** FLANGE FRAME WINDOW

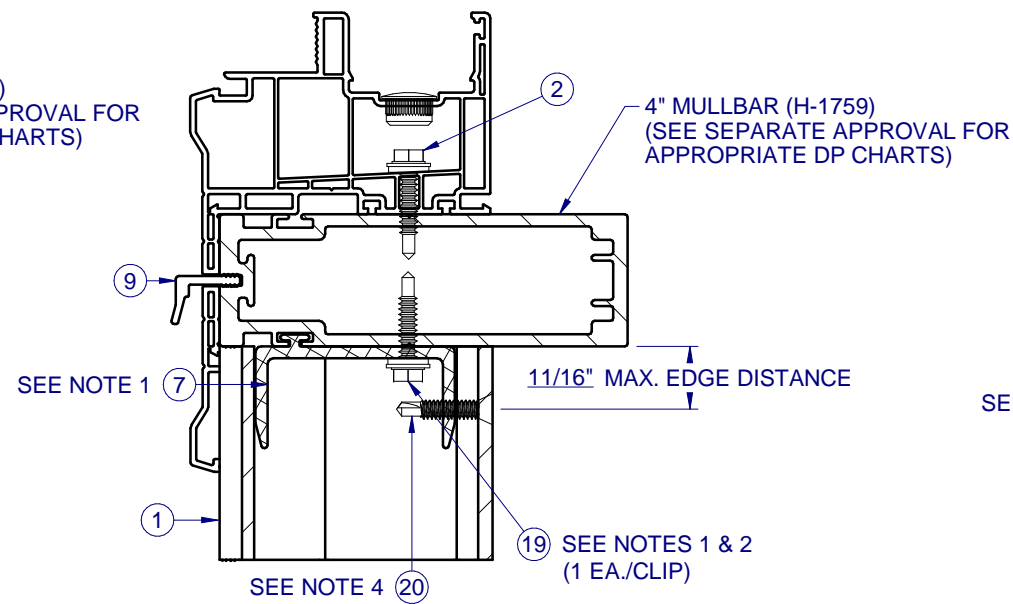

**C** 4" HORIZ. TO 3" VERT. MULLBAR SECTION  
**7** FLANGE FRAME WINDOW

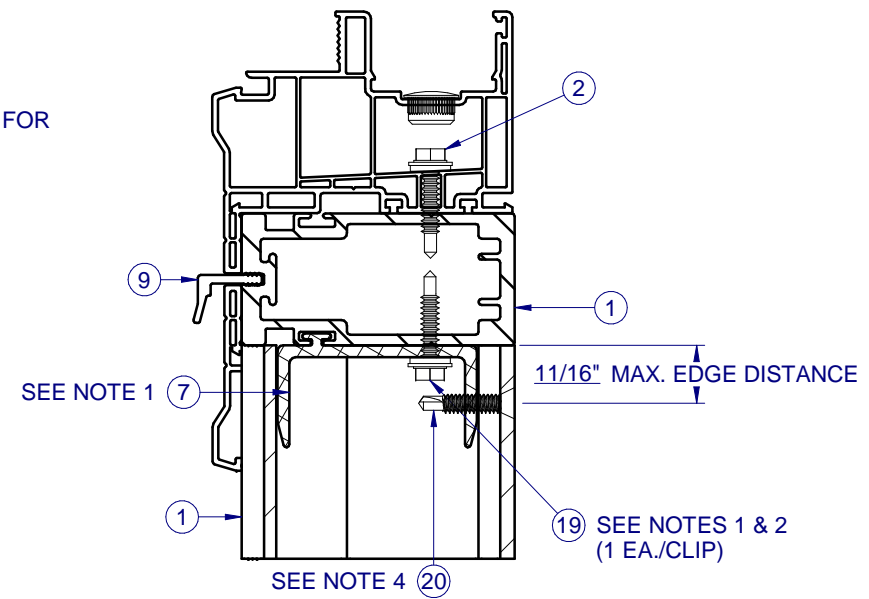

**C** 3" HORIZ. TO 3" VERT. MULLBAR SECTION  
**7** FLANGE FRAME WINDOW

**NOTES:**

1. SLIDE CLIP INTO LOCATION AND SECURE WITH ITEMS 19 (QTY 1) AND 20 (QTY 1), AS SHOWN ABOVE.
2. PRE-DRILLED HOLES (THRU H/V CLIP 1897), BY THE INSTALLER, MAY BE LOCATED AS NEEDED WHILE MAINTAINING A MINIMUM CLIP EDGE DISTANCE OF 9/32" AND A MINIMUM CENTER TO CENTER SPACING OF 1/2".
3. THE ABOVE SECTIONS APPLY TO ALL MULLBAR-TO-MULLBAR CONNECTIONS, REGARDLESS OF ORIENTATION (i.e., HORIZONTAL OR VERTICAL). THE FULL LENGTH MULL MUST BE THE SAME DEPTH, OR GREATER, THAN THE INTERSECTING MULL.
4. INTERIOR MULL ANCHOR ATTACHMENT SCREW THRU VERTICAL MULL INTO MULL CLIP. PRE-DRILL PILOT HOLE THRU ALL MATERIAL.

**3" PVC  
MULL BAR  
IMPACT**

PROPRIETARY AND CONFIDENTIAL  
THE INFORMATION CONTAINED IN THIS DRAWING IS THE SOLE PROPERTY OF CUSTOM WINDOW SYSTEMS, INC. ANY REPRODUCTION IN PART OR AS A WHOLE WITHOUT THE WRITTEN PERMISSION OF CUSTOM WINDOW SYSTEMS, INC IS PROHIBITED.

FLORIDA APPROVAL NO.:  
9520

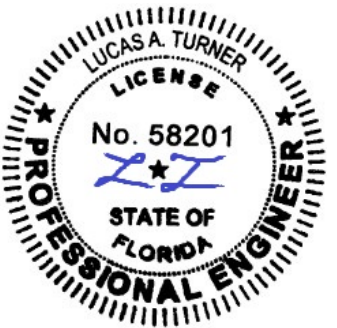

9/20/2023

LUCAS A. TURNER, P.E.  
FL PE # 58201  
Turner Engineering & Consulting, Inc.  
2428 Old Natchez Trc Trl  
Camden, TN 38320  
PH. 941-380-1574

SHEET DESCRIPTION:  
**CONFIGURATIONS AND ANCHORAGE NOTES**

DRAWN BY: MCS	DATE: 9/8/2023
DWG #: CWS-836	REV.: D
SCALE: 1:1	SHEET 8 OF 10

- NOTES:
1. THE MULL BAR IN FOCUS FOR ANY GIVEN CONFIGURATION IS SHOWN IN BOLD.
  2. AN INTERSECTED MULL BAR HAS OTHER MULL BAR(S) ATTACHED TO IT (SHOWN IN DASHES) THROUGH THE USE OF MULL BAR CLIPS. AN INTERSECTED MULL BAR WILL ALWAYS BE ATTACHED TO THE SUBSTRATE AT BOTH ENDS.
  3. NON-INTERSECTED MULL BARS CAN BE ATTACHED TO THE SUBSTRATE AND OTHER MULL BARS.

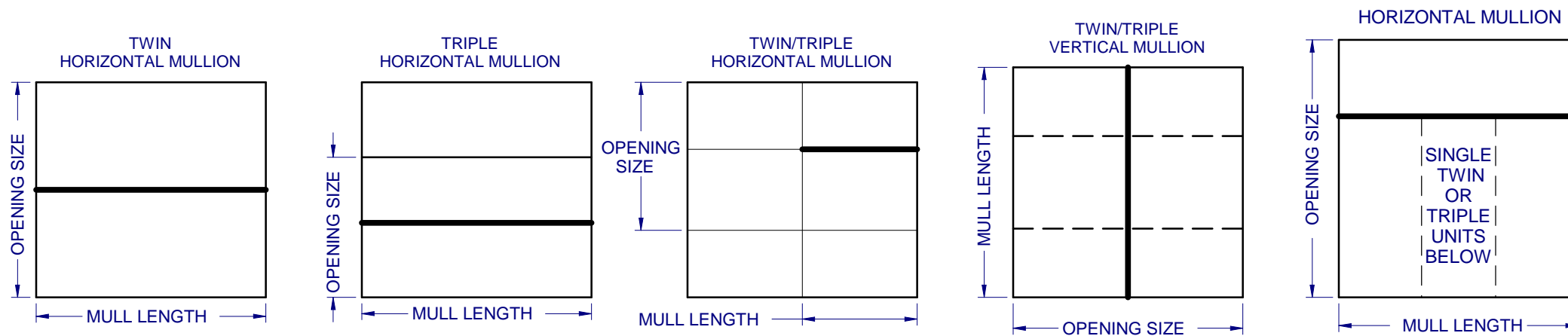
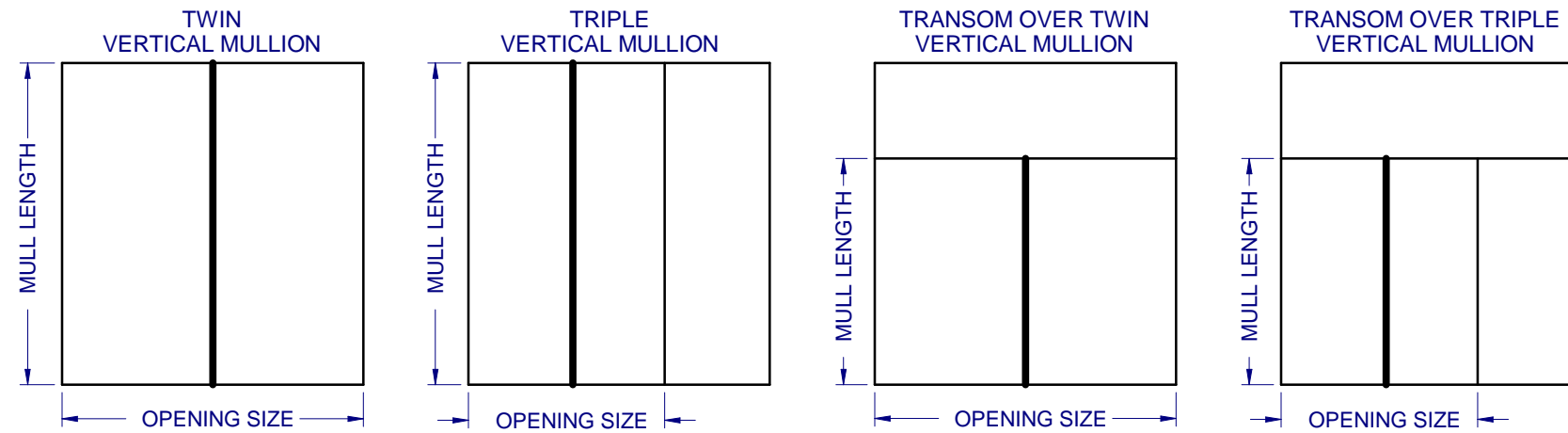

NOTES:

1. AT MULLION LOCATION, ATTACH WINDOW UNIT(S) TO MULLBAR THRU FRAME AS SPECIFIED IN WINDOW UNIT APPROVAL DOCUMENTS. IF ALUMINUM ATTACHMENT IS NOT SPECIFIED IN THE WINDOW UNIT APPROVAL DOCUMENTS, FOLLOW THE ANCHOR SPACING AS INDICATED IN THE WINDOW APPROVAL FOR ATTACHMENT TO WOOD SUBSTRATE, USING A HEX WASHER HEAD TEK SCREW OF THE SAME SIZE (#10 OR #12) AS THE WOOD SCREW INDICATED IN THE WINDOW APPROVAL. TEK SCREWS SHALL BE LONG ENOUGH TO ENSURE THREE (3) THREADS OF PENETRATION BEYOND THE INSIDE WALL OF MULLBAR.
2. MULL CLIP INSTALLATION ANCHOR TYPE, SIZE, SPACING AND EMBEDMENT SHALL BE AS SPECIFIED IN THESE DRAWINGS, SEE TABLE 1, SHEET 9.
3. ALL MULL CLIP INSTALLATION ANCHORS MUST BE MADE OF OR PROTECTED WITH A CORROSION RESISTANT MATERIAL OR COATING. DISSIMILAR METALS OR MATERIALS IN CONTACT WITH PRESSURE TREATED WOOD MUST BE PROTECTED TO PREVENT REACTION.
4. INSTALLATION ANCHORS SHALL BE IN ACCORDANCE WITH ANCHOR MANUFACTURER'S INSTALLATION INSTRUCTIONS, AND ANCHORS SHALL NOT BE USED IN SUBSTRATES WITH STRENGTHS LESS THAN THE MINIMUM SPECIFIED IN TABLE 1, SHEET 9.
5. ANCHOR EMBEDMENT TO SUBSTRATE SHALL BE BEYOND WALL DRESSING OR STUCCO. FOR CONCRETE/CMU OPENINGS, EMBEDMENT SHALL BE BEYOND WOOD BUCKS, IF USED, INTO SUBSTRATE - 1X BUCKS ARE OPTIONAL.
6. A MINIMUM CENTER-TO-CENTER SPACING SHALL BE MAINTAINED AS INDICATED BY THE PRE-DRILLED HOLES AS SHOWN IN THE CLIP LAYOUTS ON SHEETS 4-5.
7. WOOD OR MASONRY OPENINGS, BUCKS AND BUCK FASTENERS SHALL BE PROPERLY DESIGNED BY THE ARCHITECT OR ENGINEER OF RECORD AND INSTALLED TO TRANSFER WIND LOADS TO THE STRUCTURE. SUBSTRATES SHALL MEET THE MINIMUM STRENGTH REQUIREMENTS AS SHOWN IN TABLE 1, SHEET 9. CONCRETE AND MASONRY SUBSTRATES MAY NOT BE CRACKED.
8. SEALING AND FLASHING STRATEGIES FOR OVERALL WATER RESISTANCE OF INSTALLATION SHALL BE DONE BY OTHERS FOLLOWING THE CURRENT VERSION OF THE REFERENCE DOCUMENTS: FMA/AAMA 100(FIN WINDOWS), FMA/AAMA 200(FLANGE WINDOWS), FMA/WDMA 250(BOX WINDOWS), FMA/AAMA/WDMA 300(EXTERIOR DOORS)





1900 SW 44TH AVE.  
OCALA, FLORIDA 34474  
WWW.CWS.CC

### 3" PVC MULL BAR IMPACT

PROPRIETARY AND CONFIDENTIAL  
THE INFORMATION CONTAINED IN THIS DRAWING IS THE SOLE PROPERTY OF CUSTOM WINDOW SYSTEMS, INC. ANY REPRODUCTION IN PART OR AS A WHOLE WITHOUT THE WRITTEN PERMISSION OF CUSTOM WINDOW SYSTEMS, INC IS PROHIBITED.

FLORIDA APPROVAL NO.:  
9520

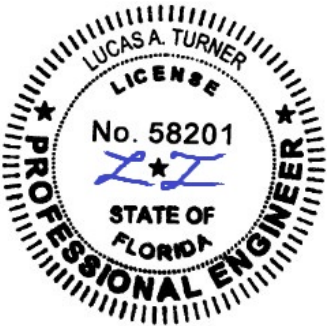

9/20/2023

LUCAS A. TURNER, P.E.  
FL PE # 58201  
Turner Engineering & Consulting, Inc.  
2428 Old Natchez Trc Trl  
Camden, TN 38320  
PH. 941-380-1574

SHEET DESCRIPTION:  
INSTALLATION DETAILS  
FLANGE

DRAWN BY: MCS	DATE: 9/8/2023
DWG #: CWS-836	REV.: D
SCALE: 1:2	SHEET 9 OF 10

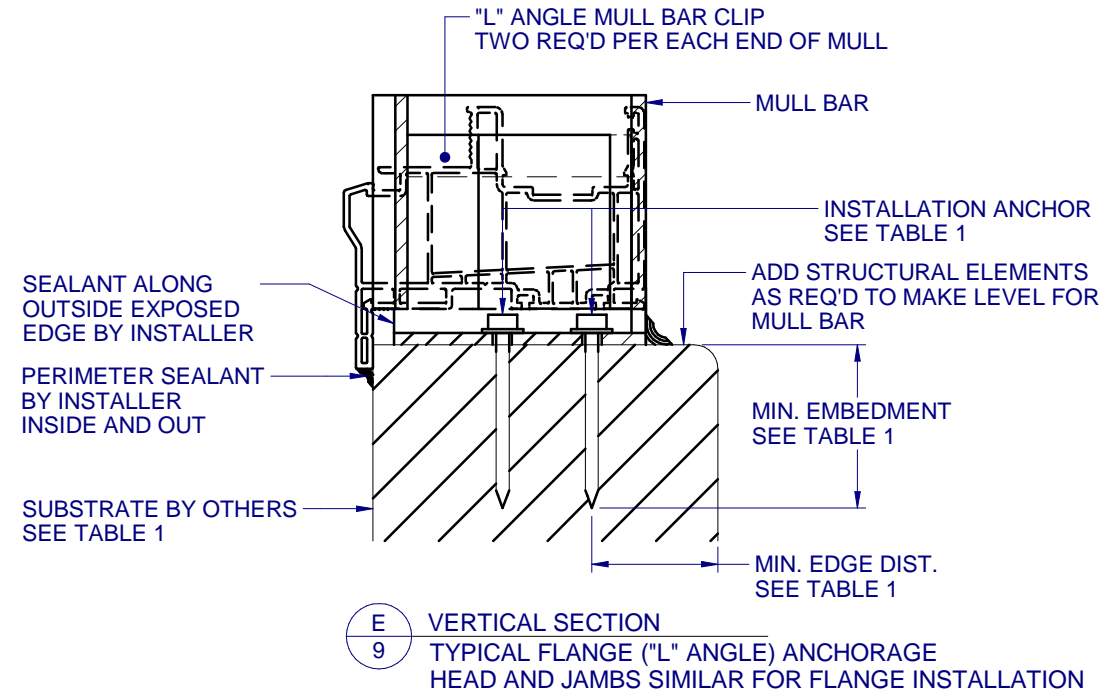
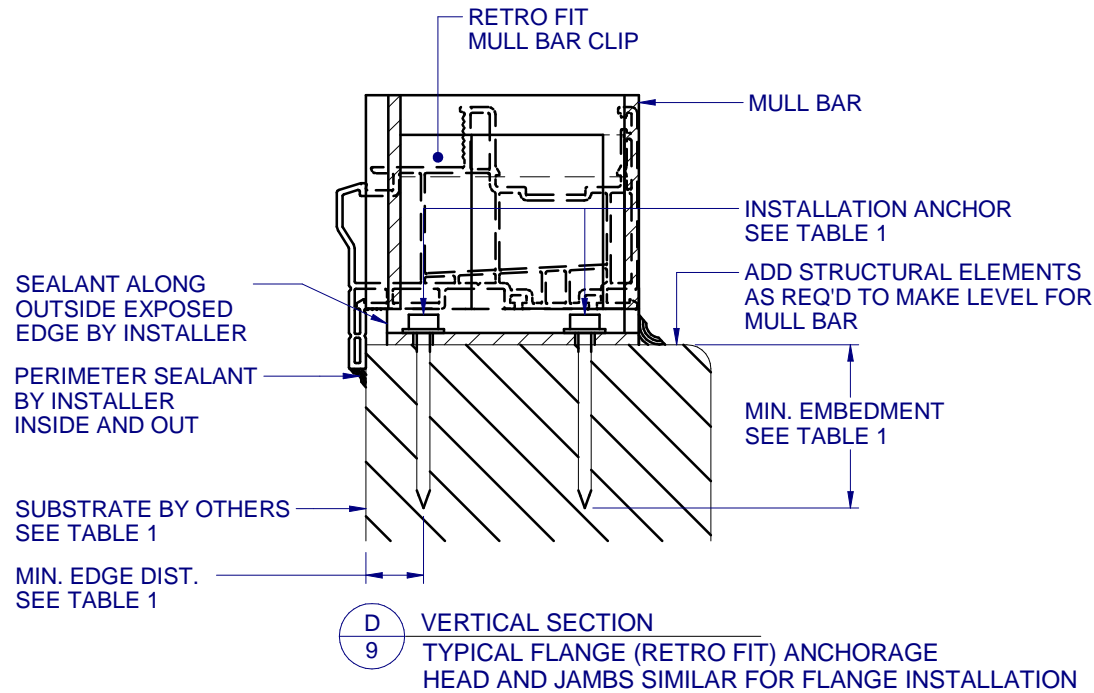

NOTES:

1. BOX FRAME MULL INSTALLATION SIMILAR TO FLANGE FRAME.
2. SILL STOOL MUST BE FLUSH AGAINST INSIDE OF MULLED WINDOWS AFTER INSTALLATION.
3. RECESS RETRO MULLION CLIP 3/8" MAX. FOR CLEARANCE OF WINDOW UNIT AS NEEDED.
4. FOUR (4) ANCHORS REQUIRED PER "T" MULL CLIP, SEE SHEETS 2-3. THREE (3) ANCHORS REQUIRED PER "L" MULL CLIP, SEE SHEETS 2-3.
5. SEAT MULLION TIGHT TO MULL CLIP.
6. FOR ANCHORAGE DETAILS FOR THE WINDOW, REFER TO THE WINDOW SPECIFIC INSTALLATION DETAILS.

TABLE 1: APPROVED MULL CLIP INSTALLATION FASTENERS

SUBSTRATE TYPE	ANCHOR TYPE	MIN. EMBEDMENT	MIN. EDGE DIST.
CONCRETE (2.0 KSI MIN.)	3/16" ITW TAPCON	1"	3"
CONCRETE (3.05 KSI MIN.)	3/16" DEWALT ULTRACON+	1-3/4"	1"
HOLLOW or GROUT-FILLED CMU (ASTM C-90)	1/4" DEWALT ULTRACON+	1-1/4"	2-1/2"
2X MIN. SOUTHERN PINE (G=0.55)	3/16" ITW TAPCON OR DEWALT ULTRACON+	1-3/8"	7/8"
2X MIN. SOUTHERN PINE (G=0.55)	#10 WOOD SCREW	1-3/8"	7/8"
16 GAUGE (0.060") MIN. STEEL STUD (33 KSI YIELD MIN)	#10-16 HILTI KWIK-FLEX OR ITW TEKS SELF-DRILLING SCREW	FULL THREAD THRU 0.060"	7/16"
1/8" ALUM. (6063-T5 MIN.) OR 1/8" STEEL (33 KSI MIN.)	#10 GRADE 5 SELF-TAPPING / DRILLING SCREW	FULL THREAD THRU 0.125"	7/16"



1900 SW 44TH AVE.  
OCALA, FLORIDA 34474  
WWW.CWS.CC

### 3" PVC MULL BAR IMPACT

PROPRIETARY AND CONFIDENTIAL  
THE INFORMATION CONTAINED IN THIS DRAWING IS THE SOLE PROPERTY OF CUSTOM WINDOW SYSTEMS, INC. ANY REPRODUCTION IN PART OR AS A WHOLE WITHOUT THE WRITTEN PERMISSION OF CUSTOM WINDOW SYSTEMS, INC IS PROHIBITED.

FLORIDA APPROVAL NO.:

9520

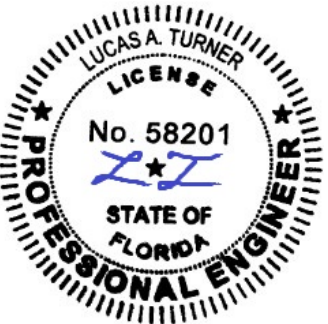

9/20/2023

LUCAS A. TURNER, P.E.  
FL PE # 58201  
Turner Engineering & Consulting, Inc.  
2428 Old Natchez Trc Trl  
Camden, TN 38320  
PH. 941-380-1574

SHEET DESCRIPTION:

INSTALLATION DETAILS  
FIN

DRAWN BY:

MCS

DATE:

9/8/2023

DWG #:

CWS-836

REV.:

D

SCALE:

1:2

SHEET

10 OF 10

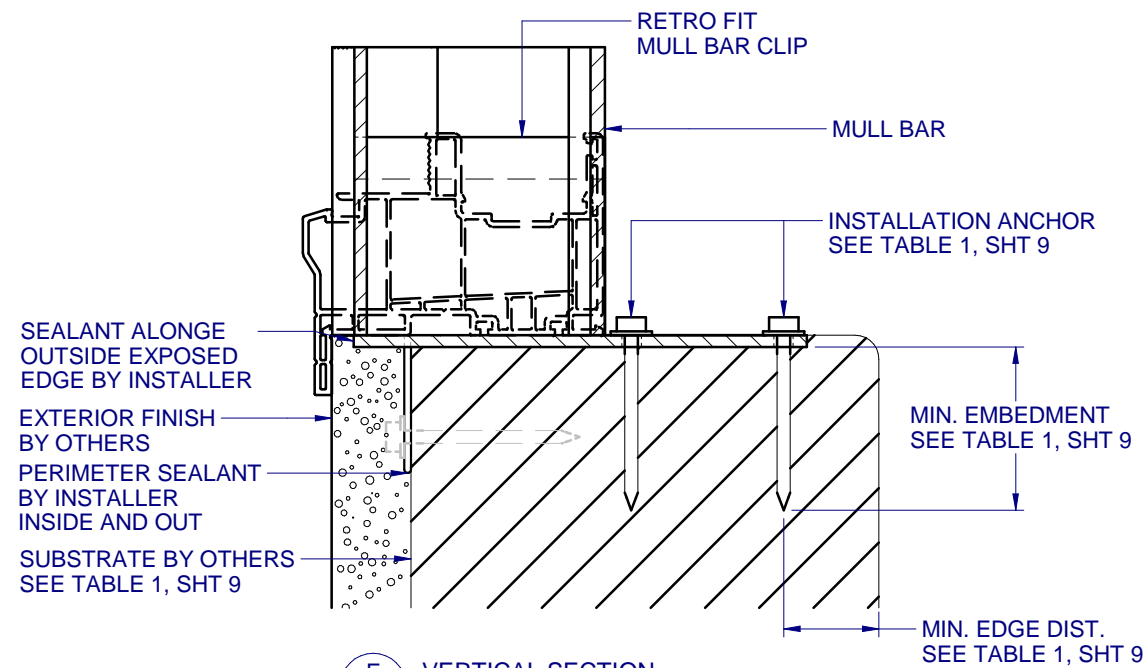

**F**  
10 VERTICAL SECTION  
TYPICAL FIN (RETRO FIT) ANCHORAGE  
HEAD AND JAMBS SIMILAR FOR FIN INSTALLATION

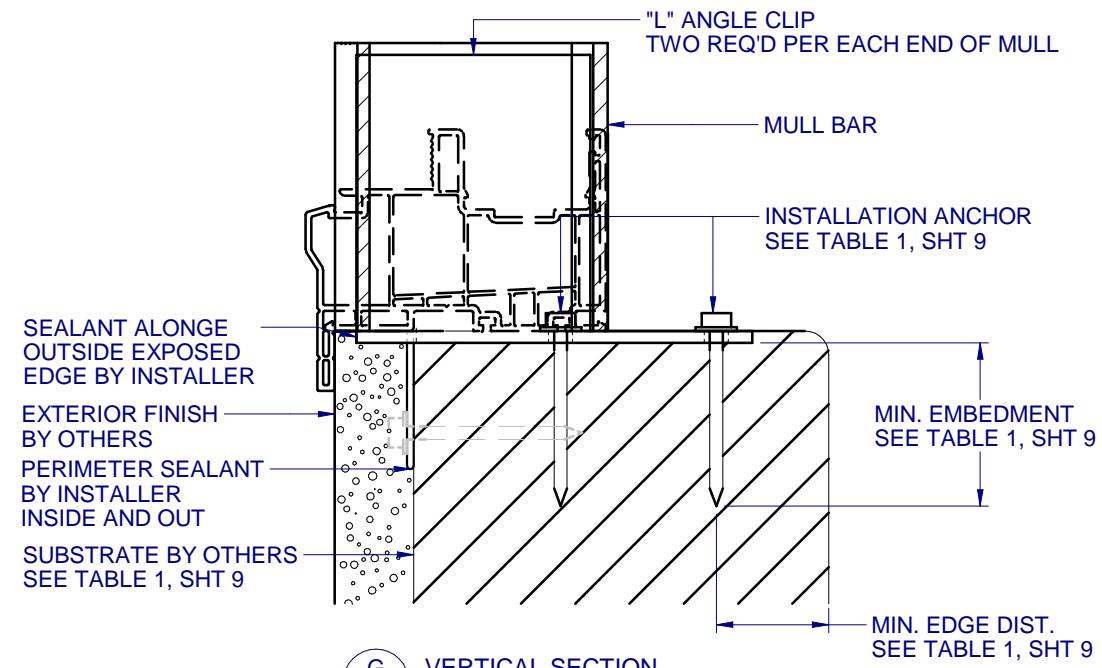

**G**  
10 VERTICAL SECTION  
TYPICAL FIN ("L" ANGLE) ANCHORAGE  
HEAD AND JAMBS SIMILAR FOR FIN INSTALLATION

NOTES:

1. SILL STOOL MUST BE FLUSH AGAINST INSIDE OF MULLED WINDOWS AFTER INSTALLATION.
2. RECESS RETRO MULLION CLIP 3/8" MAX. FOR CLEARANCE OF WINDOW UNIT AS NEEDED.
3. FOUR (4) ANCHORS REQUIRED PER "T" MULL CLIP, SEE SHEETS 2-3. THREE (3) ANCHORS REQUIRED PER "L" MULL CLIP, SEE SHEETS 2-3.
4. SEAT MULLION TIGHT TO MULL CLIP.
5. FOR ANCHORAGE DETAILS FOR THE WINDOW, REFER TO THE WINDOW SPECIFIC INSTALLATION DETAILS.