

Evaluation Report "Victorian" or "Classic" Shingle" Metal Roof Assembly

Manufacturer:
Berridge Manufacturing Company
1720 Maury Road
Houston, TX 77026
(800) 231-8127

for

Florida Product Approval
FL 11422.2 R7
Florida Building Code 7th Edition (2020)

Method: 1 - D
Category: Roofing
Sub - Category: Metal Roofing

Product: "Victorian" or "Classic" Shingle
Material: Steel
Panel Thickness: 24 gauge
Support: Wood Deck

Prepared by:

James L. Buckner, P.E., S.E.C.B.
Florida Professional Engineer # 31242
Florida Evaluation ANE ID: 1916
Project Manager: Diana Galloway
Report No. 20-227-VCS-S4W-ER
(Revises 17-128-VCS-S4W-ER, FL11422.2 R5)
Date: 09 / 17 / 20

Contents:

Evaluation Report Pages 1 – 8

This item has been electronically signed and sealed by James L. Buckner, P.E., on this date using a Digital Signature. Printed copies of this document are not considered signed and sealed, and the signature must be verified on any electronic copies.

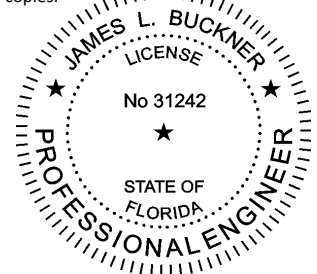

2020.09.17 13:23:17 -04'00'

Manufacturer:	Berridge Manufacturing Company 1720 Maury Road Houston, TX 77026 (800) 231-8127 www.berridge.com
Product Name:	“Victorian” or “Classic” Shingle
Product Category:	Roofing
Product Sub-Category	Metal Roofing
Compliance Method:	State Product Approval Rule 61G20-3.005 (1) (d)
Product/System Description:	“Victorian” or “Classic” Roof Shingle 24 gauge Steel roof shingle attached to Plywood Deck with screws.
Product Assembly as Evaluated:	Refer to Page 4 of this report for product assembly components/materials & standards: <ol style="list-style-type: none">1. Roof Panel2. Fasteners3. Underlayment
Support:	Type: Wood Deck (Design of support and its attachment to support framing is outside the scope of this evaluation.) Description: <ul style="list-style-type: none">• 15/32” (min.) or 19/32”(min.) (Per Table A), or greater plywood,• or Wood plank (min. specific gravity of 0.42)
Slope:	Minimum slope shall be in compliance with FBC Chapter 15 based on the type of roof covering, applicable code sections and in accordance with manufacturer’s recommendations.
Performance:	Wind Uplift Resistance: <ul style="list-style-type: none">• Design Uplift Pressure: Refer to TABLE A (Refer to “Table A” attachment details herein)
Performance Standards:	The product described herein has demonstrated compliance with:

- UL580-06 – *Test for Uplift Resistance of Roof Assemblies*
- UL 1897-12 – *Uplift test for roof covering systems*
- TAS 125-03 – *Standard Requirements for Metal Roofing Systems*

Standards Equivalency: The UL 580-94 & UL 1897-98 standard version used to test the evaluated product assembly is equivalent with the prescribed standards in UL 580-06 & UL 1897-12 adopted by the Florida Building Code 7th Edition (2020).

Code Compliance: The product described herein has demonstrated compliance with Florida Building Code 7th Edition (2020) Section 1504.3.2.

Evaluation Report Scope: This product evaluation is limited to compliance with the structural requirements of the Florida Building Code, as related to the scope section to Florida Product Approval Rule 61G20-3.001.

Limitations and Conditions of Use:

- Scope of “Limitations and Conditions of Use” for this evaluation:
This evaluation report for “Optional Statewide Approval” contains technical documentation, specifications and installation method(s) which include “Limitations and Conditions of Use” throughout the report in accordance with Rule 61G20-3.005. Per Rule 61G20-3.004, the Florida Building Commission is the authority to approve products under “Optional Statewide Approval”.
- Option for application outside “Limitations and Conditions of Use”
Rule 61G20-3.005(1)(e) allows engineering analysis for “project specific approval by the local authorities having jurisdiction in accordance with the alternate methods and materials authorized in the Code”. Any modification of the product as evaluated in this report and approved by the Florida Building Commission is outside the scope of this evaluation and will be the responsibility of others.
- This report is a building code product evaluation per FLPE rule (FAC) 61G15-36 to comply with Florida product approval rule (FAC) 61G20-3. This evaluation report is part of the Florida Building Commission approval for the listed code related criteria. This report by James Buckner, P.E. and CBUCK Engineering is not a design certification of code compliance construction submittal documentation, per FBC section 107, for any individual structure, site specific or permit design.
- All metal components and fasteners shall be corrosion resistant in accordance with applicable sections of FBC, including but limited to Sections 1504.3.2, 1506.6 and 1507.4.4.
- Design of support system is outside the scope of this report.
- Fire Classification is outside the scope of Rule 61G20-3, and is therefore not included in this evaluation.
- This evaluation report does not evaluate the use of this product for use in the High Velocity Hurricane Zone code section. (Dade & Broward Counties)

Quality Assurance: The manufacturer has demonstrated compliance of roof panel products in accordance with the Florida Building Code and Rule 61G20-3.0005 (3) for manufacturing under a quality assurance program audited by an approved quality assurance entity through **UL, LLC (FBC Organization #: QUA 9625)**.

Components/Materials **Roof Panel:** “Victorian” or “Classic” Shingle

(by Manufacturer):

Material: Steel
 Thickness: 24 gauge (min.)
 Panel Dimensions: 9" wide x 12" long (max.) Coverage
 Yield Strength: 40 ksi min.
 Steel Grade: 40
 Corrosion Resistance: In compliance with FBC Section 1507.4.3:
 • ASTM A792 coated, or
 • ASTM A653 G90 galvanized steel

Fastener:

Type: Pancake-Head Wood Screw
 Size: Option 1: #12 x 1"
 Option 2: #10 - 9 x 1"
 Corrosion Resistance: Per FBC Section 1506.6 and 1507.4.4
 Standard: Per ANSI/ASME B18.6.1

Underlayment:

Material and application shall be in compliance with FBC Section 1507.1.1 and in accordance with applicable code sections and manufacturer's recommendations.

Installation:

Installation Method:

(Refer to "TABLE A" below and drawings on Pages 6-8 of this report.)

- Fastener Spacing: **Refer to "TABLE A" Below**
(along the length of the shingle)
- Two (2) fasteners per Shingle
(Refer to "Table A" and Drawings at the end of this report for shingle fastener placement)
- Tuck bottom lock of succeeding layer of shingles into top lock of preceding layer of shingles to form an integral interlock.
- Attach shingles in a staggered pattern.
- Minimum fastener penetration thru bottom of support, 3/16".

TABLE "A"			
ALLOWABLE LOADS			
	METHOD 1	METHOD 2	METHOD 3
Design Pressure:	- 118.5 PSF	-123.5 PSF	-131 PSF
Deck Thickness (min)	15/32"	15/32"	19/32"
Fastener Spacing:	9"	9"	9"
Fastener Type:	#12	#10	#10
# of Fasteners per Shingle:	2	2	2
Shingle Fastener Placement	Detail A	Detail B	Detail B

• Allowable design pressure(s) for allowable stress design (ASD).

Install the "Victorian" or "Classic" Shingle" roof panel assembly in compliance with the installation method listed in this report and applicable code sections of FBC 7th Edition (2020). The installation method described herein is in accordance with the scope of this evaluation report. Refer to manufacturer's installation instructions as a supplemental guide for attachment.

Referenced Data:

1. TAS 125 (Per UL580 & UL 1897)
By Hurricane Test Laboratory, Inc. (FBC Organization #TST ID: 1527)
Report # 0307-0127-04, Dated: 3/9/04
2. TAS 125 (Per UL580 & UL 1897)
By Force Engineering & Testing, Inc. (FBC ORG # ID: 5328)
Report # 49-0242T-12A, B, Dated: 12/4/12
3. Quality Assurance
UL, LLC (FBC Organization #: QUA 9625)
4. Equivalency of Test Standard Certification
By James L. Buckner, P.E. @ CBUG Engineering
(FBC Organization # ANE 1916)
5. Certification of Independence
By James L. Buckner, P.E. @ CBUG Engineering
(FBC Organization # ANE 1916)

Installation Method Berridge Manufacturing Company “Victorian” or “Classic” Shingle” Roof Panel attached to Wood Deck

Profile Drawings

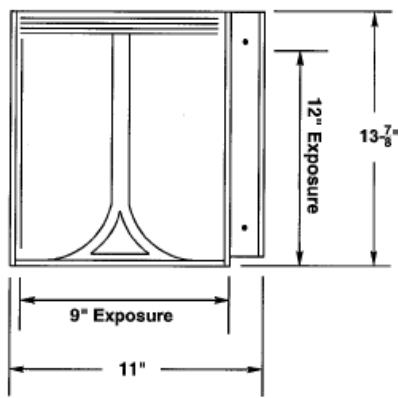

“Victorian Shingle”

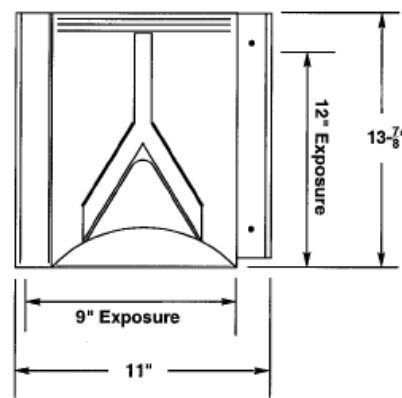

“Classic Shingle”

Typical Panel Profiles

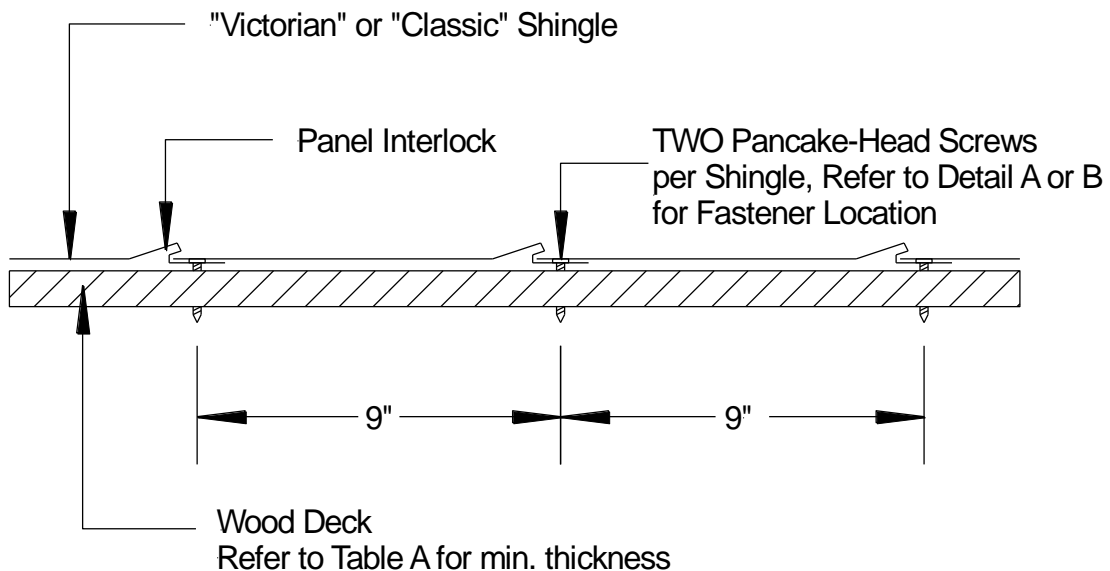

Assembly Section Profile View
(Typical Fastening Pattern Across Width)

Installation Method
Berridge Manufacturing Company
“Victorian” or “Classic” Shingle” Roof Panel attached to Wood Deck

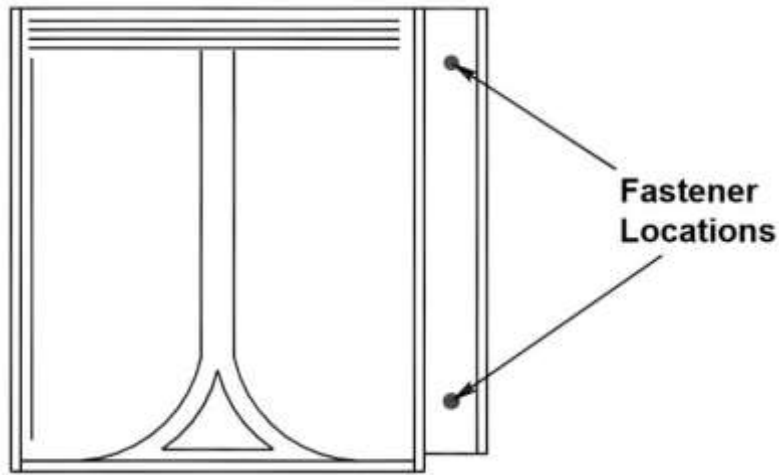

“Detail A”
Shingle Fastener Placement

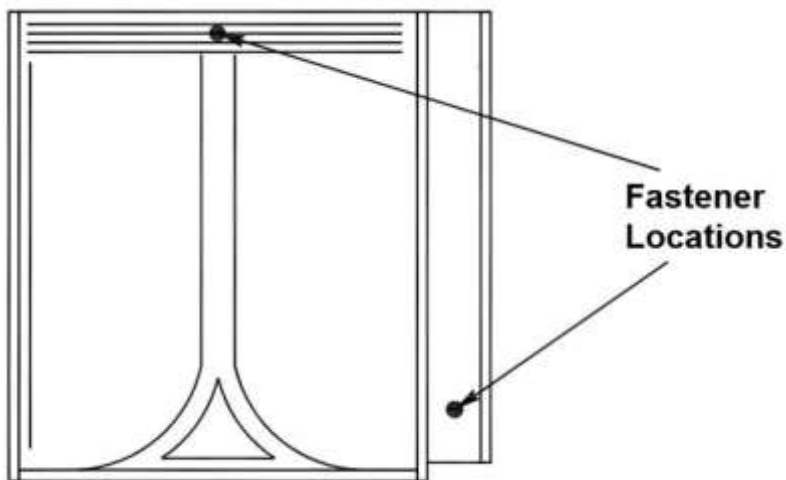

“Detail B”
Shingle Fastener Placement

Installation Method
Berridge Manufacturing Company
“Victorian” or “Classic” Shingle” Roof Panel attached to Wood Deck

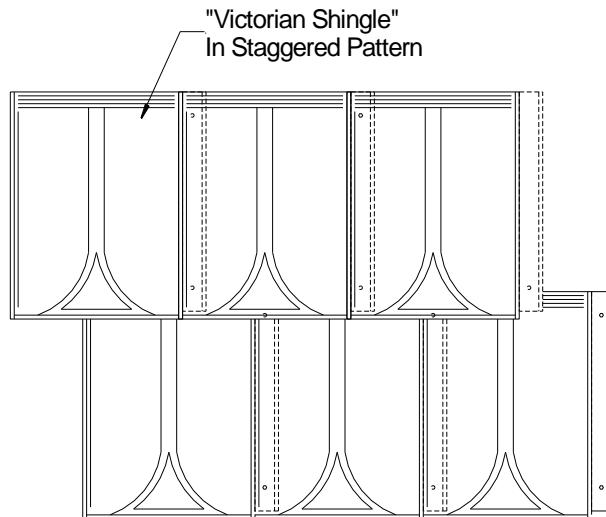

**“Victorian Shingle”
Typical Assembly Plan View**

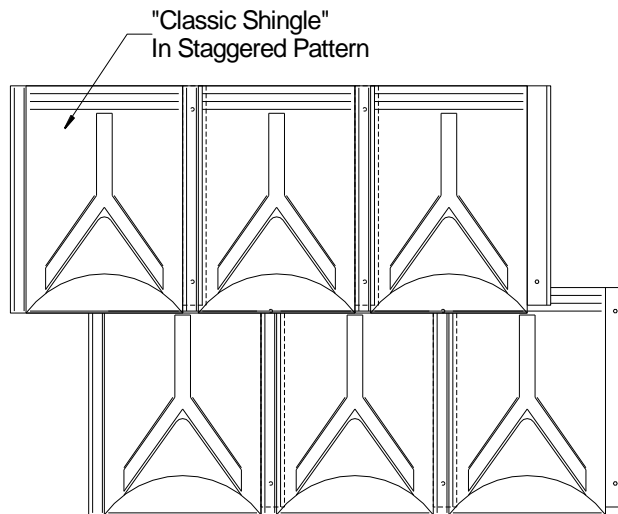

**“Classic Shingle”
Typical Assembly Plan View**