

## Evaluation Report "S-Deck or Curved S-Deck" Metal Roof Assembly

**Manufacturer:**  
**Berridge Manufacturing Company**  
1720 Maury Road  
Houston, TX 77026  
(800) 231-8127

*for*

**Florida Product Approval**  
**# FL 14210.8 R6**  
**Florida Building Code 8th Edition (2023)**

**Method: 1 - D**  
**Category: Structural Components**  
**Sub - Category: Roof Deck**

**Product:** "S-Deck or Curved S-Deck" Roof Panel  
**Material:** Steel  
**Panel Width:** 31.5"  
**Support:** Steel Purlins

### Prepared by:

James L. Buckner, P.E., S.E.C.B.  
Florida Professional Engineer # 31242  
Florida Evaluation ANE ID: 1916  
Project Manager: Diana Galloway  
Report No. 23-542-SDeck-S4P-ER  
(Revises Report No. 20-227-SDeck-S4P-ER, FL14210.9 R5)  
Date: 09/26/2023

### Contents:

Evaluation Report                      Pages 1 – 8

This item has been digitally signed and sealed by James L. Buckner, P.E., on this date below. Printed copies of this document are not considered signed and sealed, and the signature must be verified on any electronic copies.

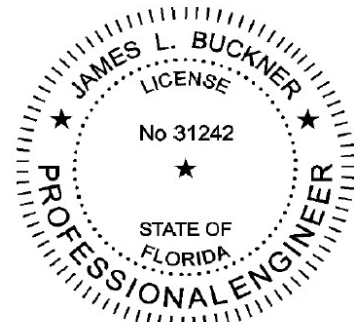

James L. Buckner, P.E.  
FL31242

Date: 2023.09.26 15:25:27  
1-04'00

<b>Manufacturer:</b>	<b>Berridge Manufacturing Company</b> 1720 Maury Road Houston, TX 77026 (800) 231-8127 <a href="http://www.berridge.com">www.berridge.com</a>
<b>Product Name:</b>	<b>“S-Deck or Curved S-Deck”</b>
<b>Product Category:</b>	Structural Components
<b>Product Sub-Category</b>	Roof Deck
<b>Compliance Method:</b>	State Product Approval Rule 61G20-3.005 (1) (d)
<b>Product/System Description:</b>	“S-Deck or Curved S-Deck” Roof Panel Steel lapped roof panel fastened into Steel Purlins.
<b>Product Assembly as Evaluated:</b>	Refer to Page 4 of this report for product assembly components/materials & standards: <ol style="list-style-type: none"><li>1. Roof Panel</li><li>2. Panel Clip</li><li>3. Fasteners</li><li>4. Insulation (Optional)</li></ol>
<b>Support:</b>	<b>Type:</b> Steel Purlins (Design of steel support and its attachment to support framing is outside the scope of this evaluation.) <b>Description:</b> <ul style="list-style-type: none"><li>• 16 Gauge minimum</li><li>• Yield Strength: 50 ksi minimum</li></ul>
<b>Slope:</b>	Minimum slope shall be in compliance with FBC Chapter 15 based on the type of roof covering, applicable code sections and in accordance with manufacturer’s recommendations.
<b>Arch Minimum Radius for Curved Panel:</b>	5’ - 0”
<b>Performance:</b>	Wind Uplift Resistance: <ul style="list-style-type: none"><li>• Design Uplift Pressure: (Refer to “Table A” attachment details herein)</li></ul> <b>METHOD 1: - 78.3 PSF</b> <b>METHOD 2: - 190 PSF</b>

- Performance Standards:** The product described herein has demonstrated compliance with:  
ASTM E 1592-05 (2017) – *Test Method for Structural Performance of Sheet Metal Roof and siding Systems By Uniform Static Air Pressure Difference*
- Standards Equivalency:** The ASTM E 1592-01 standard version used to test the evaluated product assembly is equivalent with the prescribed standards in ASTM E 1592-05 (2017) adopted by the Florida Building Code 8th Edition (2023).
- Code Compliance:** The product described herein has demonstrated compliance with Florida Building Code 8th Edition (2023), Section 1504.3.2.
- Evaluation Report Scope:** This product evaluation is limited to compliance with the structural requirements of the Florida Building Code, as related to the scope section to Florida Product Approval Rule 61G20-3.001.
- Limitations and Conditions of Use:**
- Diaphragm and axial load capacity is outside the scope of this evaluation.
  - Scope of “Limitations and Conditions of Use” for this evaluation:  
This evaluation report for “Optional Statewide Approval” contains technical documentation, specifications and installation method(s) which include “Limitations and Conditions of Use” throughout the report in accordance with Rule 61G20-3.005. Per Rule 61G20-3.004, the Florida Building Commission is the authority to approve products under “Optional Statewide Approval”.
  - Option for application outside “Limitations and Conditions of Use”  
Rule 61G20-3.005(1)(e) allows engineering analysis for “project specific approval by the local authorities having jurisdiction in accordance with the alternate methods and materials authorized in the Code”. Any modification of the product as evaluated in this report and approved by the Florida Building Commission is outside the scope of this evaluation and will be the responsibility of others.
  - This report is a building code product evaluation per FLPE rule (FAC) 61G15-36 to comply with Florida product approval rule (FAC) 61G20-3. This evaluation report is part of the Florida Building Commission approval for the listed code related criteria. This report by James Buckner, P.E. and CBUGK Engineering is not a design certification of code compliance construction submittal documentation, per FBC section 107, for any individual structure, site specific or permit design.
  - All metal components and fasteners shall be corrosion resistant in accordance with applicable sections of FBC.
  - Design of support system is outside the scope of this report. Support shall be designed by others and shall comply with the FBC Chapters 22 for steel and Chapter 16 for structural loading.
  - Fire Classification is outside the scope of Rule 61G20-3, and is therefore not included in this evaluation.
  - This evaluation report does not evaluate the use of this product for use in the High Velocity Hurricane Zone code section. (Dade & Broward Counties).
- Quality Assurance:** The manufacturer has demonstrated compliance of roof panel products in accordance with the Florida Building Code and Rule 61G20-3.0005 (3) for manufacturing under a quality assurance program audited by an approved quality assurance entity through **UL, LLC (FBC Organization #: QUA 9625)**.

**Components/Materials  
(by Manufacturer):**

**Roof Panel:**

Material: Berridge "S-Deck or Curved S-Deck"  
Steel  
Thickness: 24 gauge  
Panel Width: 31.5" (max.) Coverage  
Rib Height: 7/8"  
Yield Strength: 40 ksi min.  
Steel Grade: 40  
Corrosion Resistance: In compliance with FBC Section 1507.4.3:

- ASTM A792 coated

**Fastener:**

FASTENER 1:

Type: Panel to Deck Fastener  
Hex-Head Screw with WSW  
Size : #12 - 14 x 3/4"  
Corrosion Resistance: Per FBC Section 1506.6 and 1507.4.4  
Standard: Per FBC Section 1506.6

FASTENER 2:

Type: Panel to Panel, Stitch Fastener  
Hex-Head Screw with WSW  
Size : #12 - 14 x 1"  
Corrosion Resistance: Per FBC Section 1506.6 and 1507.4.4  
Standard: Per FBC Section 1506.6

**Components/Materials  
(by Others):**

**Insulation (Optional):**

Type 1:

Type: Rigid Insulation Board  
Thickness: 3" (max.)  
Properties:  
Density: 20 psi min.  
Or Compressive Strength: 2.25 pcf (lbs/ft<sup>3</sup>) min.

Type 2:

Thickness: Compressible Blanket Insulation  
6" max. before compression

**Insulation Notes:**

- Rigid Insulation shall meet minimum density OR compressive strength.
- Insulation shall comply with FBC Section 1508. When insulation is incorporated, fastener length shall conform to penetrate thru bottom of support a minimum of 3/4".

**Installation:**

**Installation Method:**

(Refer to **"TABLE A"** below and drawings at the end of this report.)

- Purlin Spacing: **Refer to "TABLE A" Below**
- Fastener spacing: **Refer to "TABLE A"**  
(along the purlin, in the valley of:  
Method 1: every third corrugation  
Method 2: every other corrugation)
- Sidelap spacing: **12" o.c.** (along the length of the side laps)
- Minimum fastener penetration thru bottom of support, 3/4".  
(through flange of steel purlins)

<b>TABLE "A"</b>		
<b>ALLOWABLE LOADS</b>		
	<b>METHOD 1:</b>	<b>METHOD 2:</b>
<b>Design Pressure:</b>	<b>- 78.3 PSF</b>	<b>- 190 PSF</b>
Purlin Spacing:	60" (5'- 0)	30" (2'- 6")
Fastener Spacing:	8"	5-1/3"
Side-lap Spacing:	12"	12"
Span Condition:	3 or more	3 or more
Notes: • Allowable design pressure(s) for allowable stress design (ASD). • Fastener Attachment to Steel Supports May Be Designed By A Qualified Design Professional As Required By The Florida Building Code For Site Specific Projects. • Diaphragm and axial load capacity are not included in this evaluation.		

Install the "S-Deck or Curved S-Deck" roof panel assembly in compliance with the installation method listed in this report and applicable code sections of FBC 8th Edition (2023). The installation method described herein is in accordance with the scope of this evaluation report. Refer to manufacturer's installation instructions as a supplemental guide for attachment.

**Referenced Data:**

1. TAS 125-03 Uplift Test (per ASTM E 1592-01)  
By Force Engineering & Testing Inc., Inc. (FBC Organization #TST ID:5328)
  - Report # 49-0007T-07 A-C, Report Date: 3/21/07  
Test Specimen(s) A,B,C (Method 1)
  - Report # 49-0007T-07 D, Report Date: 3/21/07  
Test Specimen(s) D (Method 2)
2. Quality Assurance  
UL, LLC (FBC Organization #: QUA 9625)
3. Equivalency of Test Standard Certification  
By James L. Buckner, P.E. @ CBUCK Engineering  
(FBC Organization # ANE 1916)
4. Certification of Independence  
By James L. Buckner, P.E. @ CBUCK Engineering  
(FBC Organization # ANE 1916)

## Installation Method Berridge Manufacturing Company "S-Deck or Curved S-Deck" Steel Roof Panel attached to Steel Purlins"

### Drawings

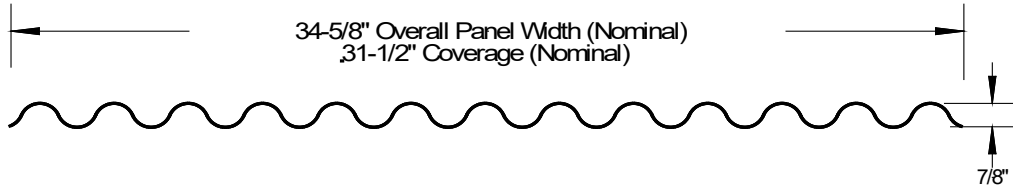

**Typical Panel Profile**

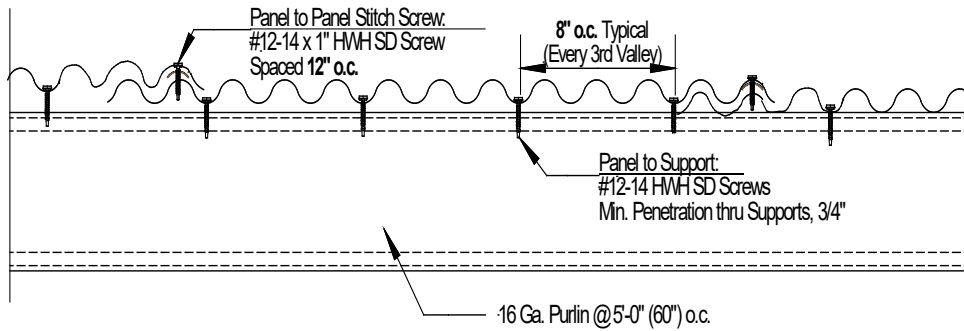

### METHOD 1:

**Assembly Profile View - Typical Fastening Pattern Across Row**

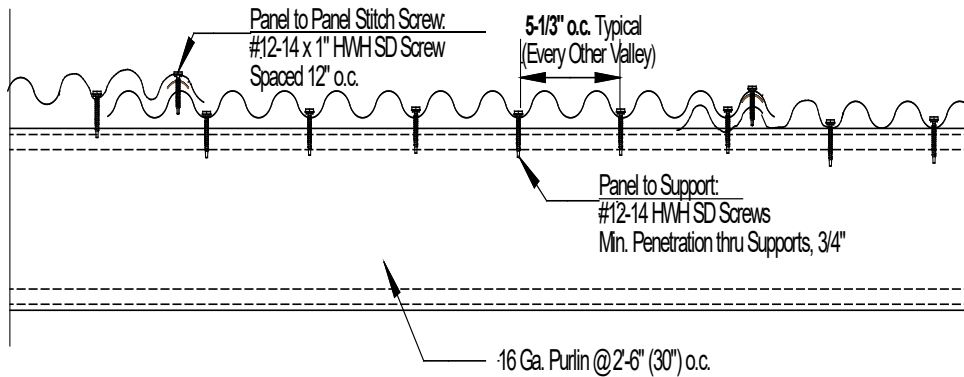

### METHOD 2:

**Assembly Profile View - Typical Fastening Pattern Across Row**

TABLE "A"		
	METHOD 1:	METHOD 2:
<b>Design Pressure:</b>	- 78.3 PSF	- 190 PSF
<b>Purlin Spacing:</b>	60" (5' - 0)	30" (2' - 6")
<b>Fastener Spacing:</b>	8"	5-1/3"
<b>Side-lap Spacing:</b>	12"	12"
<b>Span Condition:</b>	3 or more	3 or more

## Installation Method Berridge Manufacturing Company "S-Deck or Curved S-Deck" Steel Roof Panel attached to Steel Purlins

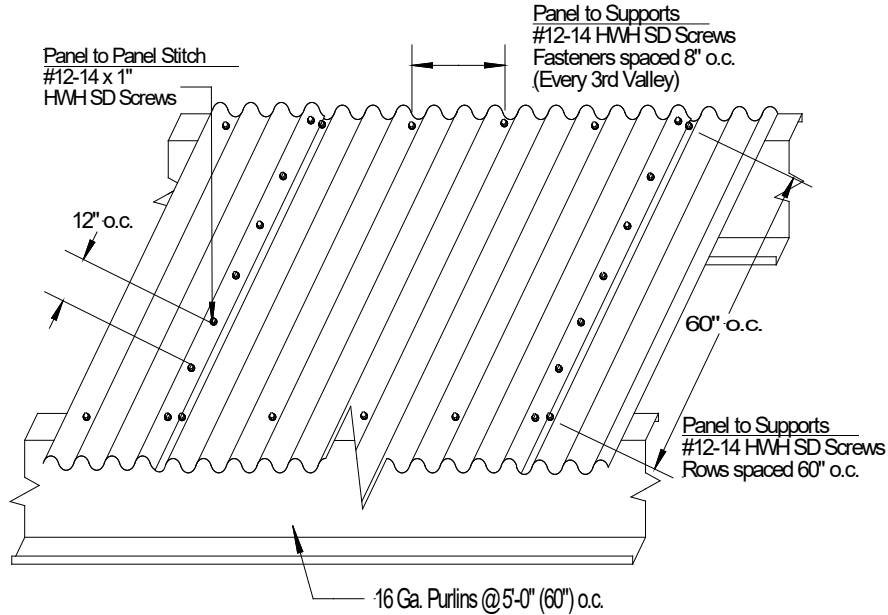

**METHOD 1:**  
Typical "S-Deck" Roof Assembly Isometric View

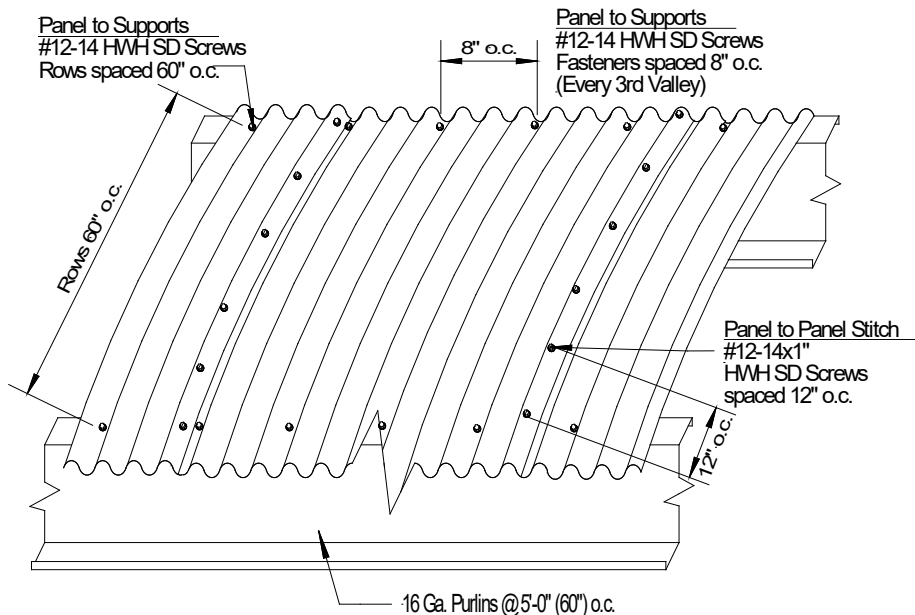

**METHOD 1:**  
Typical "Curved S-Deck" Roof Assembly Isometric View

## Installation Method Berridge Manufacturing Company "S-Deck or Curved S-Deck" Steel Roof Panel attached to Steel Purlins

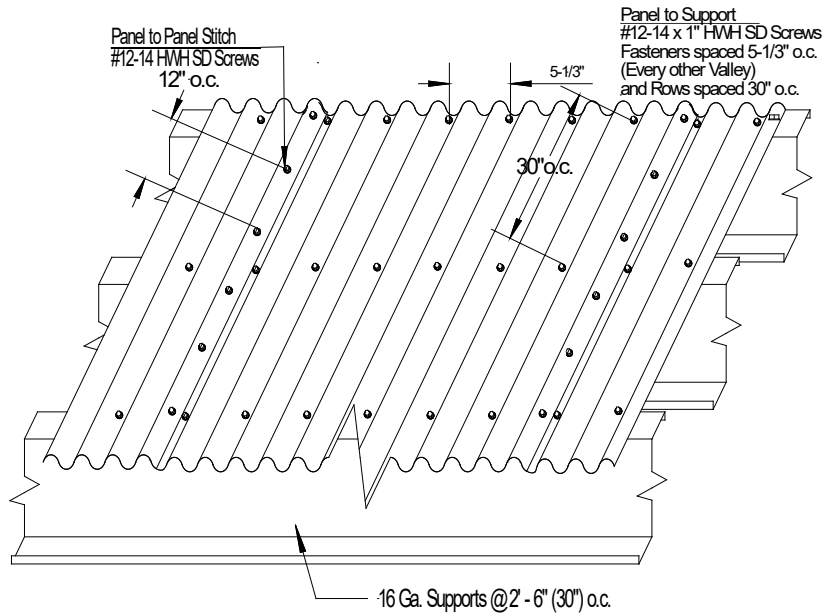

**METHOD 2:**  
 Typical "S-Deck" Roof Assembly Isometric View

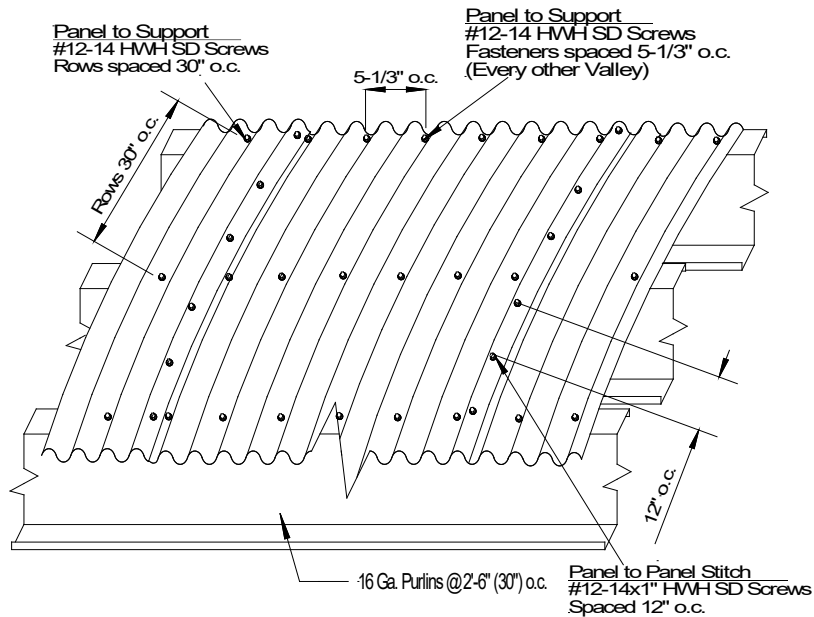

**METHOD 2:**  
 Typical "Curved S-Deck" Roof Assembly Isometric View