

TEST REPORT

Report No.: B0805.01-801-44

Rendered to:

GLASSCRAFT DOOR COMPANY
Houston, Texas

PRODUCT TYPE: Fiberglass In-Swing Glazed Double Doors
SERIES/MODEL: Fiberglass Door

Title	Summary of Results
Design Pressure	+1513 Pa (+31.6 psf)
Negative Design Pressure	-1657 Pa (-34.6 psf)

This report contains in its entirety:

Cover Page: 1 page
Report Body: 6 pages
Drawings: 13 pages

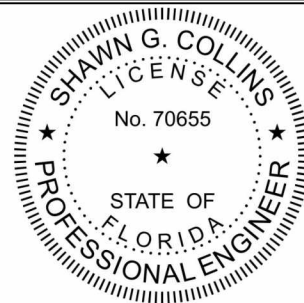

Digitally Signed by: Shawn G. Collins

2011.08.03 15:28:14 -04'00'

Reference must be made to Report No. B0805.01-801-44, dated 06/21/11 for complete test specimen description and detailed test results.

1.0 Report Issued To: GlassCraft Door Company
2002 Brittmoore Street
Houston, Texas 77043

2.0 Test Laboratory: Architectural Testing, Inc.
2865 Market Loop
Southlake, Texas 76092
(817) 410-7202

3.0 Project Summary:

3.1 Product Type: Fiberglass In-Swing Glazed Double Doors

3.2 Series/Model: Fiberglass Door

3.3 Compliance Statement: Results obtained are tested values and were secured by using the designated test method(s). The samples tested met the performance requirements set forth in the referenced test procedures for a +1513/-1657 Pa (+31.6/-34.6 psf)

3.4 Test Dates: 06/15/2011 - 06/20/2011

3.5 Test Location: Architectural Testing, Inc. test facility in Southlake, Texas.

3.6 Test Sample Source: The test specimens were provided by the client. Representative samples of the test specimens will be retained by Architectural Testing for a minimum of four years from the test completion date.

3.7 Drawing Reference: The test specimen drawings have been reviewed by Architectural Testing and are representative of the test specimen(s) reported herein. Test specimen construction was verified by Architectural Testing per the drawings located in Appendix B. Any deviations are documented herein or on the drawings.

3.8 List of Official Observers:

<u>Name</u>	<u>Company</u>
Chris Longoria	Architectural Testing, Inc.
Tom Klein	Architectural Testing, Inc.

4.0 Test Method(s):

ASTM E 330-02, *Test Method for Structural Performance of Exterior Windows, Curtain Walls and Doors by Uniform Static Air Pressure Difference.*

5.0 Test Specimen Description:

5.1 Product Sizes:

Test Specimens #1 - #2:

Overall Area: 4.5 m ² (48.3 ft ²)	Width		Height	
	millimeters	inches	millimeters	inches
Overall size	1848	72-3/4	2426	95-1/2
Operable leaf	914	36	2426	95-1/2
Fixed leaf	914	36	2426	95-1/2

5.2 Frame Construction:

Frame Member	Material	Description
Head & jambs	Compressed fiberboard	1-1/4" x 4-5/8" cross section

	Joinery Type	Detail
All corners	Coped & butted	Secured with four #9 x 3" wood screws

5.3 Leaf Construction:

Leaf Member	Material	Other
Rails & stiles	Fiberglass clad foam core	Solid, single pour foam core

5.0 Test Specimen Description: (Continued)

5.4 Weatherstripping:

Description	Quantity	Location
U-shaped foam-filled vinyl bulb gasket with vinyl tongue insert	1 row	Interior face frame jambs
U-shaped foam-filled vinyl bulb gasket with vinyl tongue insert	1 row	Interior face frame head
U-shaped foam-filled vinyl bulb gasket with vinyl tongue insert	1 row	Interior face astragal
Rubber double row bottom door sweep	1 row	Threshold face bottom of each leaf

5.5 Drainage: Sloped threshold was utilized.

5.6 Glazing:

Glass Type	Spacer Type	Interior Lite	Exterior Lite	Glazing Method
1-1/8" IG	Aluminum box spacer	1/8" tempered	Laminated consisting of 2 pieces of 1/8" tempered (0.090" interlayer)	Interior glazed against a fiberglass glass stop to the exterior and a screw-in fiberglass glass stop to the interior. The glass was sealed full perimeter on the interior and exterior.

Location	Quantity	Daylight Opening		Glass Bite
		millimeters	inches	
Operable leaf	1	533 x 1607	21 x 63-1/4	0.50"
Fixed leaf	1	533 x 1607	21 x 63-1/4	0.50"

5.7 Hardware:

Description	Quantity	Location
Door hinge	4 per leaf	12" & 28" up from bottom; 9" & 34-1/2" down from top
Flush bolt	2	Inserted into top and bottom of astragal
3 point lock set	1	Inserted into lock stile of operable leaf
Flush bolt guide	2	One at each end of the fixed panel lock stile

5.0 Test Specimen Description: (Continued)

5.8 Reinforcement: No reinforcement was utilized.

5.9 Screen Construction: No screen was utilized.

6.0 Installation:

The specimen was installed into a Spruce-Pine-Fir wood buck. The rough opening allowed for a 1" shim space.

Location	Anchor Description	Anchor Location
Jambs	#9 x 3" wood screws	12" from corners, 24" on center thereafter; through top and bottom mounting holes of hinges
Head & threshold	#9 x 3" wood screws	4" from corners, 12" on center thereafter

7.0 Test Results: The temperature during testing was 27.8°C (82°F). The results are tabulated as follows:

Title of Test	Results	Allowed	Note
Uniform Load Deflection, per ASTM E 330 taken at lock stile +1513 Pa (+31.6 psf) -1657 Pa (-34.6psf)	2.8 mm (0.11") 16.3 mm (0.64")	Report Only	1, 2
Uniform Load Structural, per ASTM E 330 taken at lock stile +2270 Pa (+47.4 psf) -2485Pa (-51.9 psf)	0.5 mm (0.02") <0.3 mm (<0.01")	Report Only	1, 2

General Note: All testing was performed in accordance with the referenced standard(s).

Note 1: Loads were held for 10 seconds.

Note 2: Tape and film were used to seal against air leakage during structural testing. In our opinion, the tape and film did not influence the results of the test.

The service life of this report will expire on the stated Test Record Retention End Date, at which time such materials as drawings, data sheets, samples of test specimens, copies of this report, and any other pertinent project documentation, shall be discarded without notice.

If test specimen contains glazing, no conclusions of any kind regarding the adequacy or inadequacy of the glass in any glazed test specimen(s) can be made. This report does not constitute certification of this product nor an opinion or endorsement by this laboratory. It is the exclusive property of the client so named herein and relates only to the specimen(s) tested. This report may not be reproduced, except in full, without the written approval of Architectural Testing, Inc.

For ARCHITECTURAL TESTING, Inc.



Digitally Signed by: Tom Klein

Tom Klein
Technician



Digitally Signed by: Shawn G. Collins

Shawn G. Collins, P.E.
Laboratory Support Engineer

AC:hd

Attachments (pages): This report is complete only when all attachments listed are included.
Appendix-A: Drawings (12)

This report produced from controlled document template ATI 00479, issued 03/01/11.

<u>Rev. #</u>	<u>Date</u>	<u>Page(s)</u>	<u>Revision(s)</u>
1	08/02/11	1	Added FL PE Seal.
		5	Replaced Andy Costs signature with Shawn Collins.
		Appendix A	Replaced drawings

Test Report No.: B0805.01-801-44
Report Date: 06/21/11
Test Record Retention End Date: 06/20/15

Appendix A

Drawings

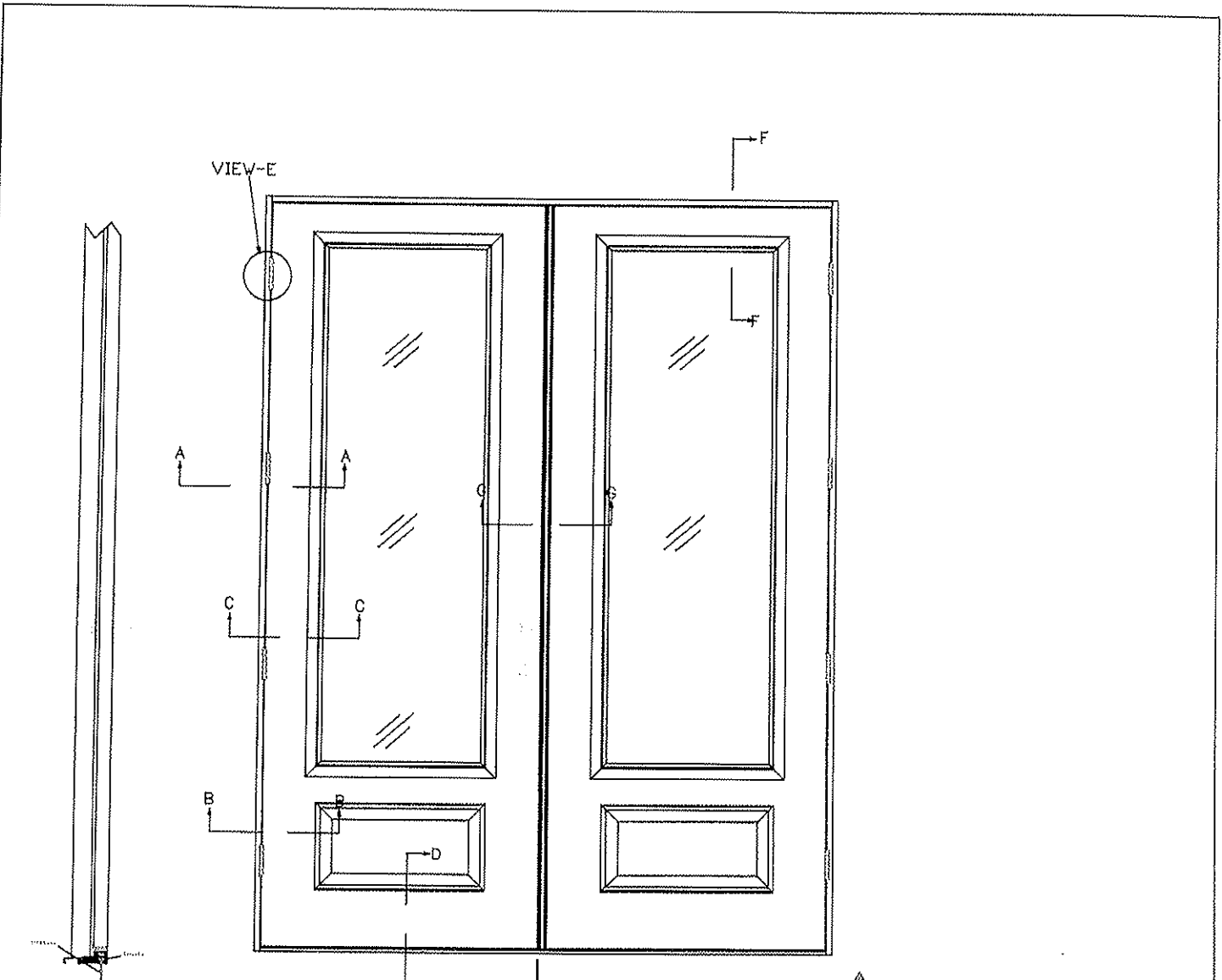

In Swing

ELEVATION

Inside View / In Swing



Architectural Testing

Test sample complies with these detail:
Deviations are noted.

Report# B0865.02-801.44
Date Le/23/11 Tech HO

Glass*Craft

Fiberglass Glazed Doors



Architectural Testing

Test sample complies with these details.
Deviations are noted.

Report#

PD055-08-S01-44

Date

6/23/11

Tech

HD

Install (2) 3" #8 Wood
Screws Per Hinge.

Penrond 4"x4" 5/8" Radius Hinge

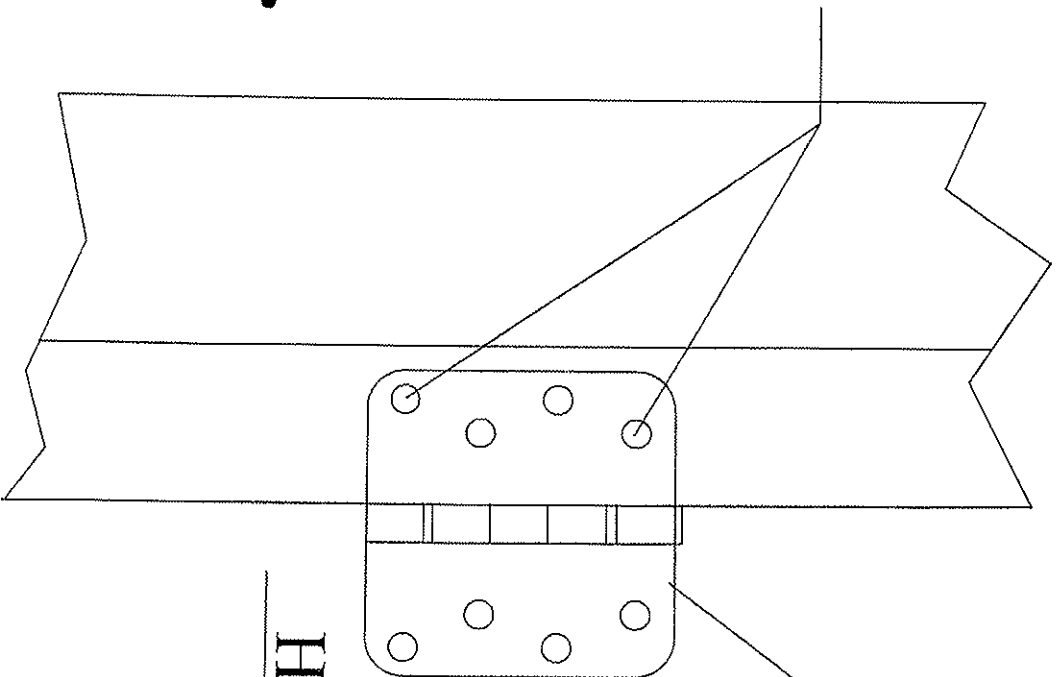

Hinge Detail

Glass*Craft

Fiberglass Glazed Doors

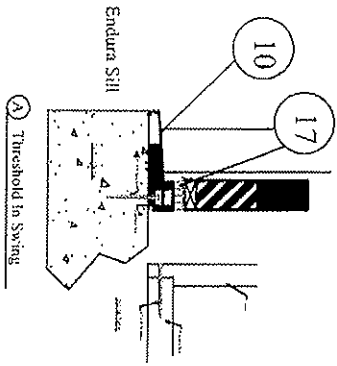

A Threshold In Swing

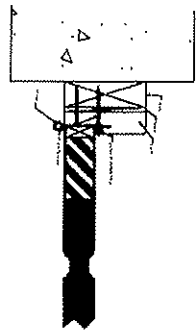

B Panel

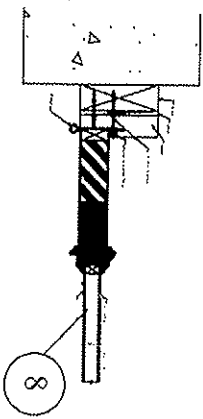
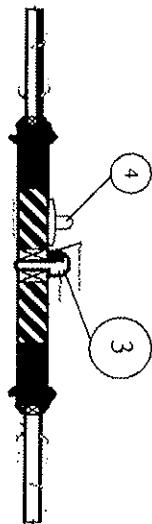

C Frame & Glass

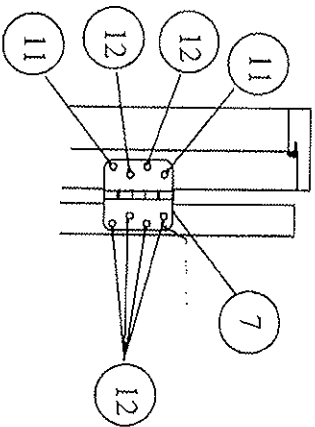

D Door Hinge



Architectural Testing

Test sample complies with these details.
 Deviations: *see notes*

Report by BOSSAS-DZ-SOL-44
 Date 10/25/11 Tech AKO

Glass*Craft

Fiberglass Glazed Doors

List of Material

Item #	Description	Material
1	Masonry	CONC.
2	2x Buck	Wood
3	Astrical Imperial T-1-7ST	Alum.
4	Imperial USA Ltd. 168MPL	Metal
5	Glass Frame	Plastic
7	Penrond 4"x4" 5/8" Radius Hinge	Metal
8	Impact Glass	Glass
10	Endura Sill ZAIL 5866 / I/S	Alum.
11	3" #9 Wood screw	Metal
12	#9x1" PFH Wood Screw	Metal
13	Imperial Lock Set IH400 OP6	Metal
16	Door Jam	Composite
17	Bottom Door sweep	Rubber
18	10-32 Sex Bolt	Metal
20	weather strip	Foam
21	Endura Sill ZAIL 5866 / O/S	Alum.



Endura Sill
ZAIL 5866 / I/S (10)

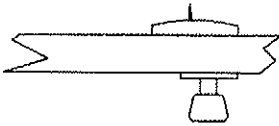

Imperial Lock Set (13)

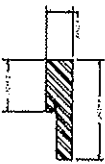

Door Jam (16)



weather strip (20)



Astrical (3)



Glass (8)

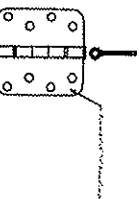

Penrond 4"x4" 5/8" Radius Hinge (7)



Bottom Door sweep (17)

Outer Frame



Inner Frame

(5)



Architectural Testing

Test sample complies with these details.
Deviations are noted.

Report# 2085-02-01-14

Date 10/21/11 Tech AD

Glass*Craft

Fiberglass Glazed Doors

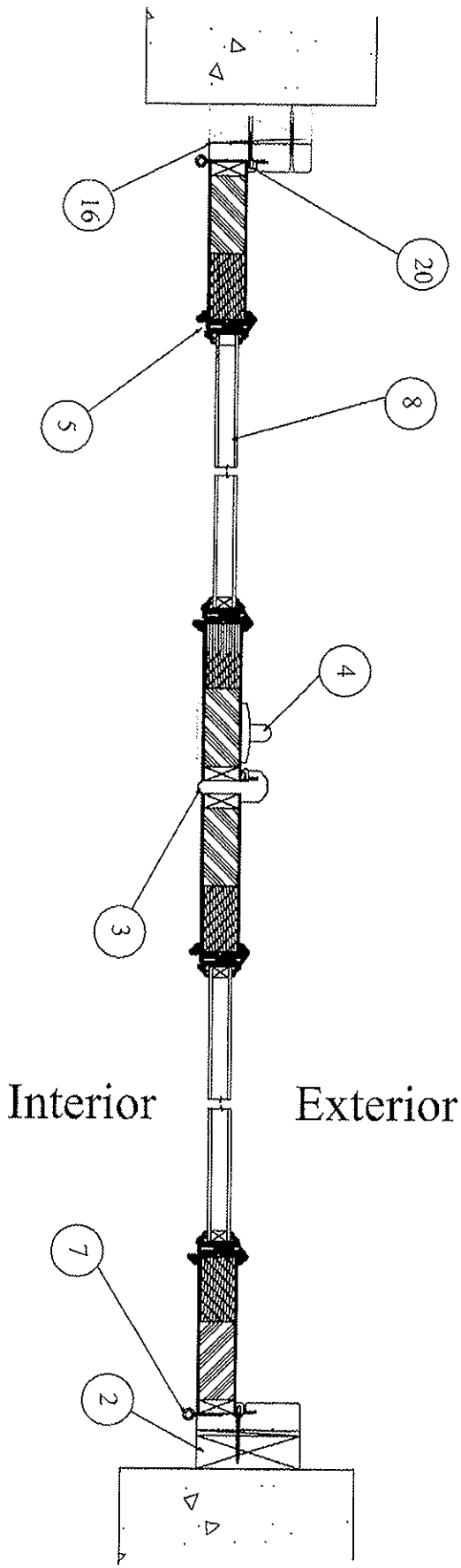

Horizontal Cross Section

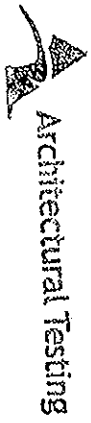

Architectural Testing
 Test sample complies with these details.
 Deviations are noted.

Report# DD05-02861-44
 Date 6/23/11 Tech AKO

Glass*Craft
 Fiberglass Glazed Doors

DO NOT SCALE DRAWING

REV	DESCRIPTIONS	REV BY	DATE
A	INITIAL ISSUE	WHITE	02/04/09

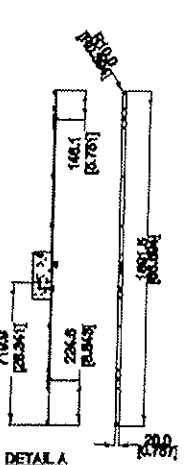

DETAIL A
6-8 TONGUE
MULTIPoint LOCK

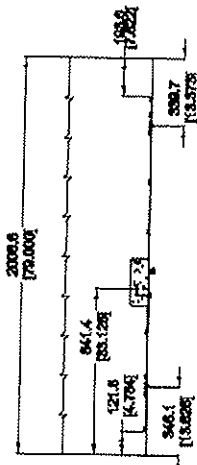

DETAIL B
6-8 LOCK
SIMULATION

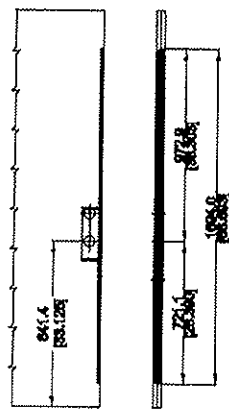

DETAIL C
6-8 LOCK DOOR
PANEL PREP

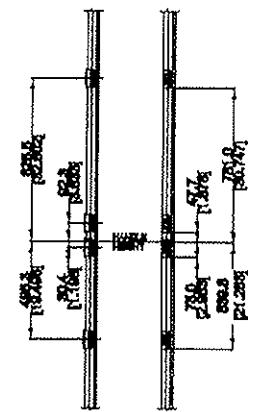

DETAIL D
ADJUSTABLE STRIKE DETAIL

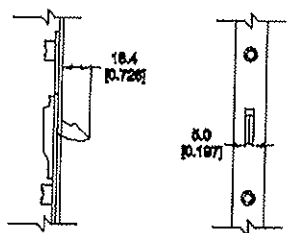

DETAIL E
TONGUE DETAIL

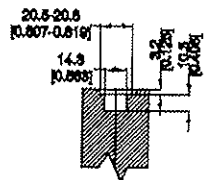

DETAIL F
EURO-GROOVE DETAIL

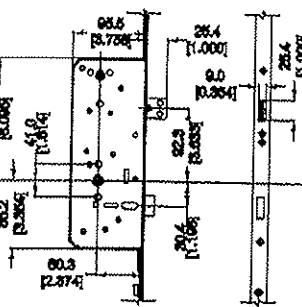
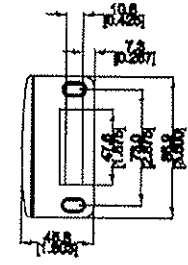

DETAIL G
CENTER CASING DETAIL

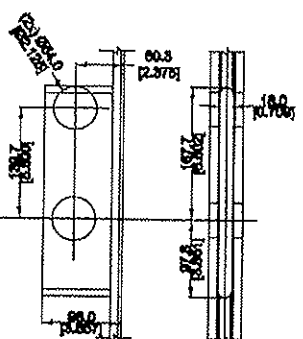

DETAIL H
CENTER CASING MORTISE DETAIL

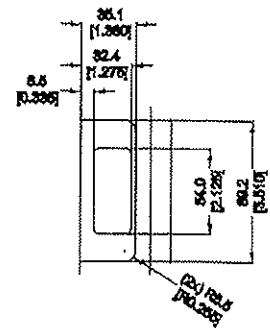

DETAIL I
ADJUSTABLE
STRIKE DETAIL

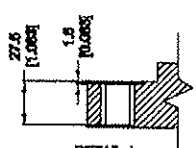

DETAIL J
ADJUSTABLE
STRIKE ROUTE



Test sample complies with these details.
Deviations are noted.

Report# BD205.02-861-44

	DRAWING No. - MPT-68-2P375		REV. SHEET A 1/1	DESCRIPTION 6' 8" TONGUE MULTIPoint LOCK DETAIL (2-3/8" BACKSET)	Tech: <u>HTD</u>		
	CAD INFO - PROJECTS/MP/TONGUE			DRAWN - C. WHITE		SCALE -	
			DATE - 02/04/09				
IMPERIAL USA Ltd.							

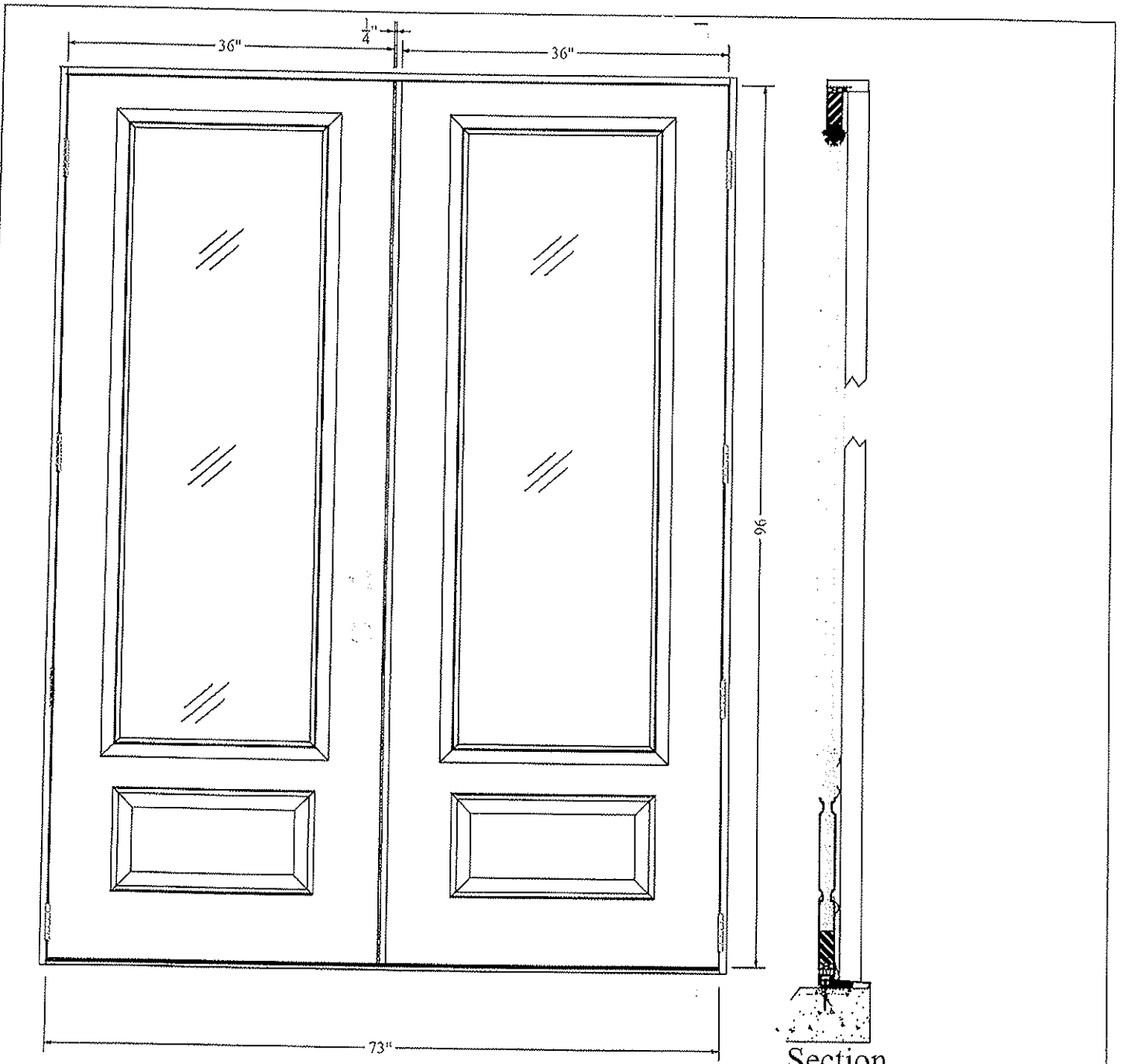

Section
H-H



Architectural Testing

Test sample complies with these details.
Deviations are noted.

Report# BO85.02-801-44
Date 6/23/11 Tech JKO

Glass*Craft
Fiberglass Glazed Doors

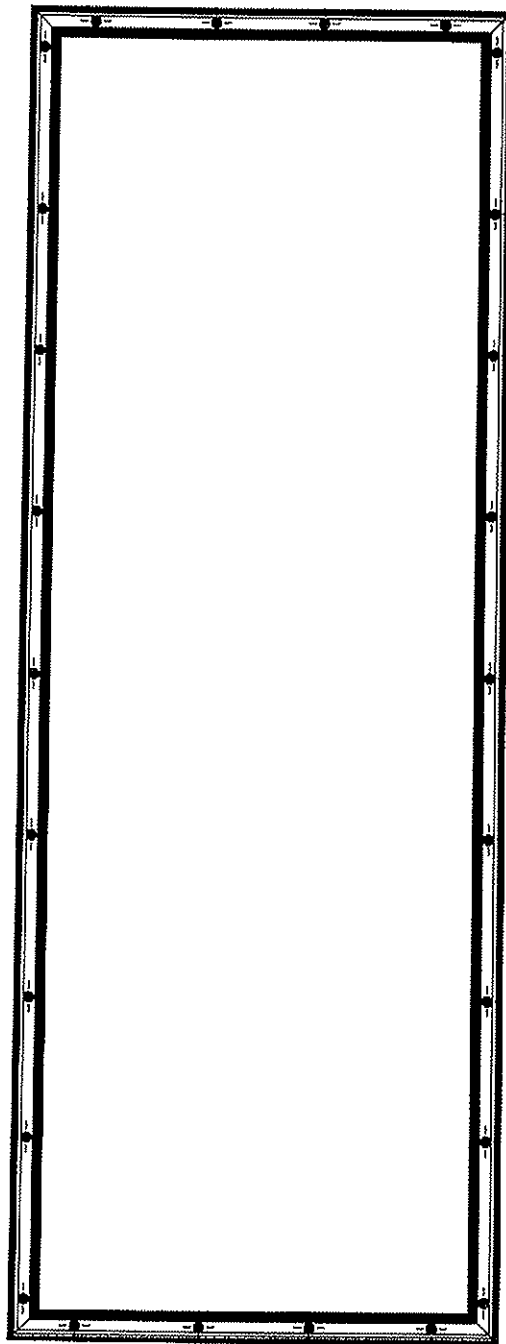
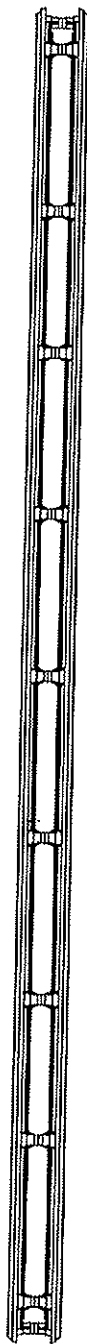

Architectural Testing

Test sample complies with these details.
Deviations are noted.

Report# BO805-01801-44

Date 6/23/11 Tech AK

Glass*Craft
Fiberglass Glazed Doors

Glass

67"

21 $\frac{1}{2}$ "



Architectural Testing

Test sample complies with these details.
Deviations are noted.

Report# 730805-801-1144
Date 6/23/11 Test HO

Glass*Craft
Fiberglass Glazed Doors

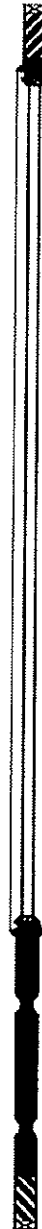
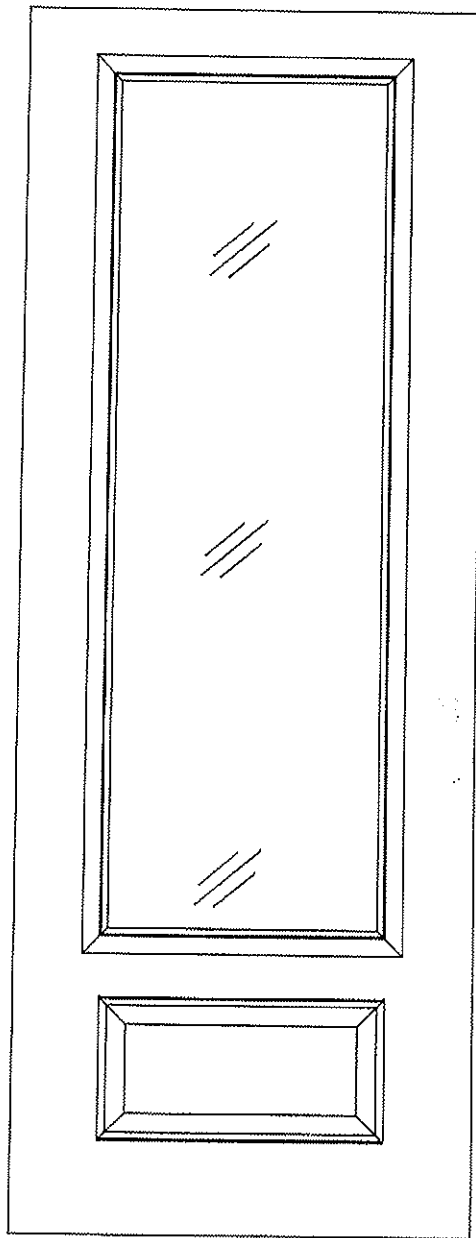

Architectural Testing

Test sample complies with these details.
Deviations are noted.

Report# BD805-81-44
Date 6/23/11 Tech H2

Glass*Craft

Fiberglass Glazed Doors

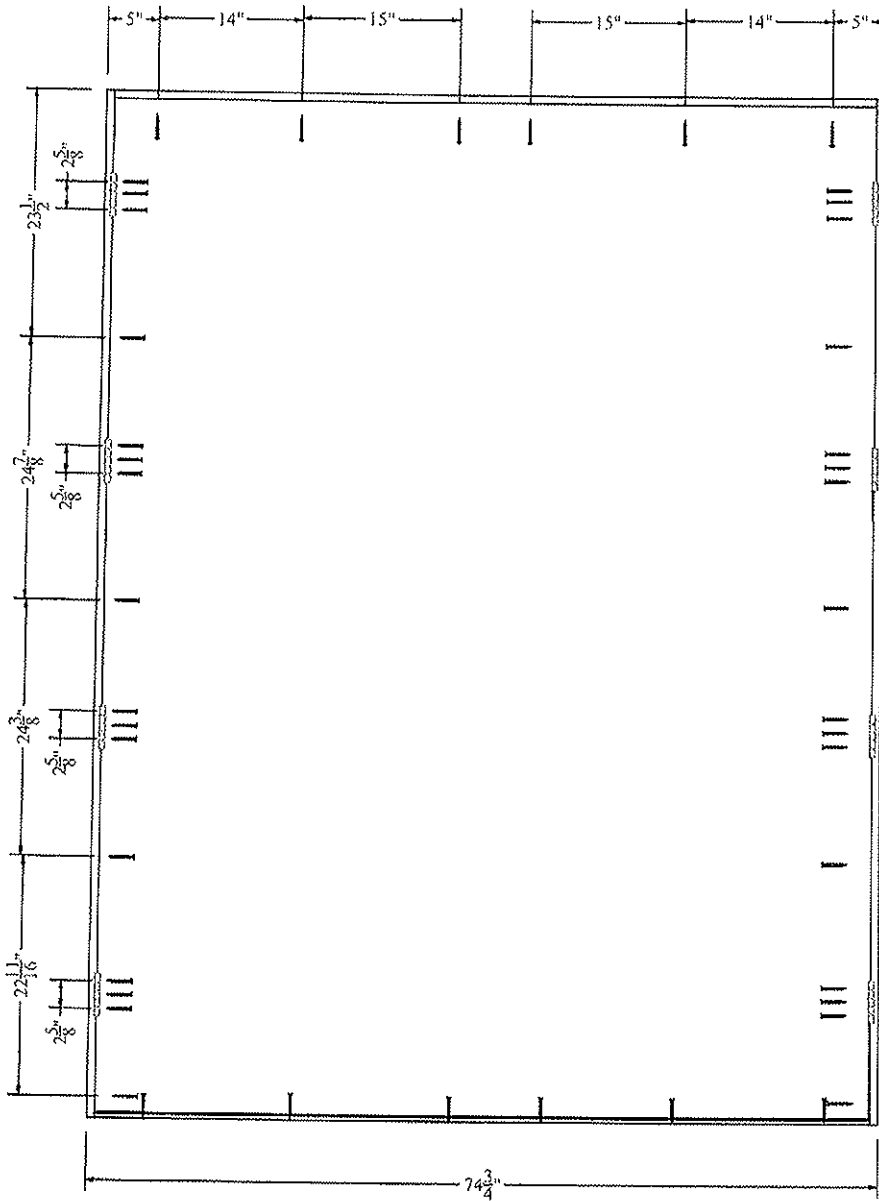

ANCHORING LOCATION

Architectural Testing

Test sample complies with these details.
Deviations are noted.

Report # PT0805.02-801-44
Date 06/20/11 Tech JKO

Glass*Craft
Fiberglass Glazed Doors

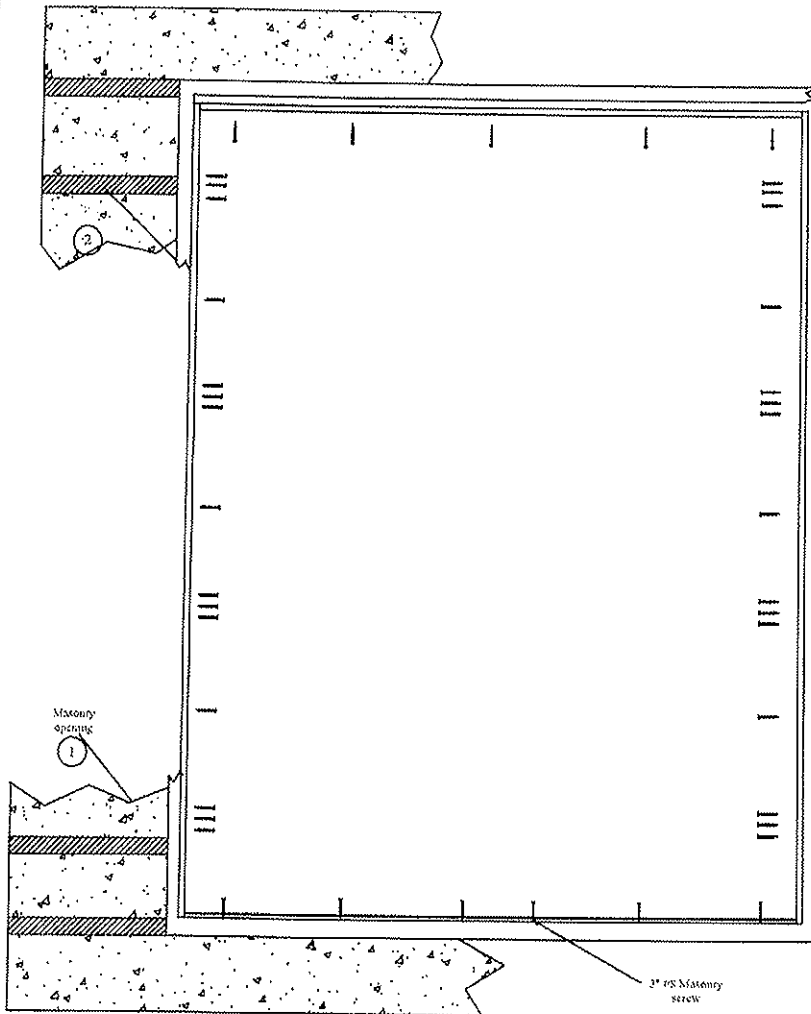

ANCHORING LAYOUT

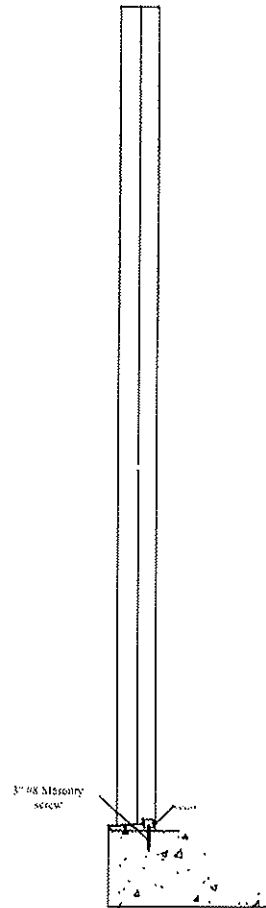

Set frame sill in concrete or bed of caulk



Architectural Testing

Test sample complies with these details.
Deviations are noted.

Report# BOS05 52-801-44
Date 6/23/11 Tech WQ

Glass*Craft
Fiberglass Glazed Doors