

**EVALUATION REPORT OF
CENTRAL STATES MANUFACTURING, INC.
'M-LOC PANEL'**

**FLORIDA BUILDING CODE 6TH EDITION (2017)
FLORIDA PRODUCT APPROVAL
FL 30071.1
STRUCTURAL COMPONENTS
ROOF DECK**

**Prepared For:
Central States Manufacturing, Inc.
302 Jane Place
Lowell, AR 72745
Telephone: (800) 356-2733
Fax: (800) 356-2971**

**Prepared By:
Bala Sockalingam, Ph.D., P.E.
Florida Professional Engineer #62240
1216 N Lansing Ave., Suite C
Tulsa, OK 74106
Telephone: (918) 492-5992
FAX: (866) 366-1543**

**This report consists of
Evaluation Report (3 Pages including cover)
Installation Details (1 Page)**

**Report No. C2289-1
Date: 8.9.2019**



Manufacturer: Central States Manufacturing, Inc.

Product Name: M-Loc Panel

Panel Description: 36" wide coverage with (7) 0.8" high ribs at 6" o.c

Materials: Min. 26 ga., 80 ksi steel or min. 24 ga., 50 ksi steel. Galvanized coated steel (ASTM A653) or Galvalume coated steel (ASTM A792) or painted steel (ASTM A755). Corrosion resistant as per FBC 2017 Section 1507.4.3.

Support Description: Min. 16 ga., 50 ksi steel section. (Must be designed by others)

Slope: 1/2:12 or greater in accordance with FBC 2017 Section 1507.4.2. Requires applied lap sealant for roof slopes less than 3:12.

Design Uplift Pressure: 43.2 psf at fastener spacing of 60 o.c. (3 or more spans)
(Factor of Safety = 2) 114.7 psf at fastener spacing of 24 o.c. (3 or more spans)

Panel Attachment: All fasteners are corrosion resistant as per FBC 2017 Section 1507.4.4.
At interior supports #12-14 x 1-1/4" long SDS with integral washer at 12" o.c. across panel width
At panel ends #12-14 x 1-1/4" long SDS with integral washer at 6" o.c. across panel width
Sidelap attachment: 1/4"-14 x 7/8" long SDS with washer @ 24" o.c.

Test Standards: Roof assembly tested in accordance with ASTM E1592-05(2017). 'Test Method for Structural Performance of Sheet Metal Roof and Siding Systems by Uniform Static Air Pressure Difference' and FM 4470 Section 5.5 'Resistance to Foot Traffic'.

Test Equivalency: The test procedures in ASTM E1592-05(2017) comply with test procedures prescribed in ASTM E1592-05(2012).

Code Compliance: The product described herein has demonstrated compliance with FBC 2017 Section 1507.4.

Product Limitations: Design wind loads shall be determined for each project in accordance with FBC 2017 Section 1609 or ASCE 7-10 using allowable stress design. The maximum fastener spacing listed herein shall not be exceeded. The design pressure for reduced fastener spacing may be computed using rational analysis prepared by a Florida Professional Engineer. This evaluation report is not applicable in High Velocity Hurricane Zone. Fire classification is not within scope of this Evaluation Report. Refer to FBC 2017 Section 1505 and current approved roofing

materials directory or ASTM E108/UL790 report from an accredited laboratory for fire ratings of this product.

Supporting Documents: ASTM E1592 Test Reports
ENCON Technology Inc.
Project No. C2285-1, Reporting Date 8/8/19

FM 4470 Test Report
ENCON Technology Inc.
Project No. C2285-2, Reporting Date 8/7/19

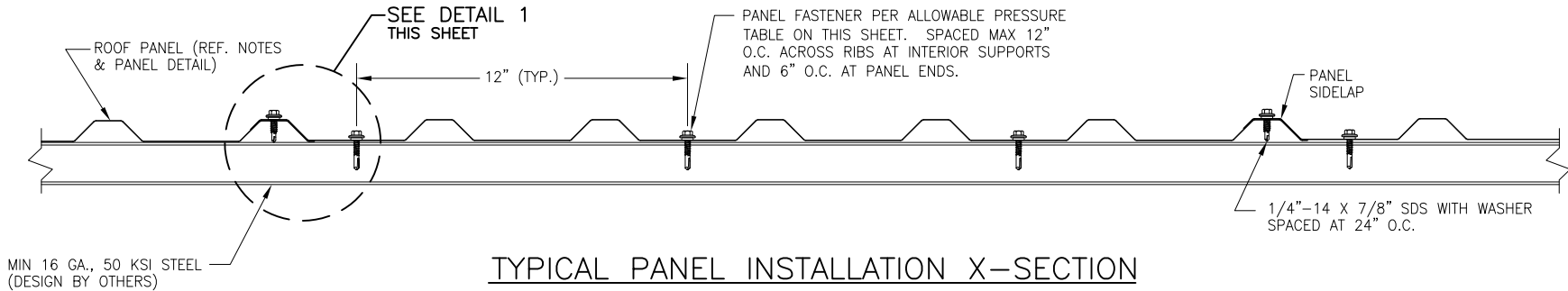

TYPICAL PANEL INSTALLATION X-SECTION

ALLOWABLE UPLIFT PRESSURE

PANEL FASTENERS SPACING ALONG RIB	PRESSURE (PSF)
60"	43.2
24"	114.7

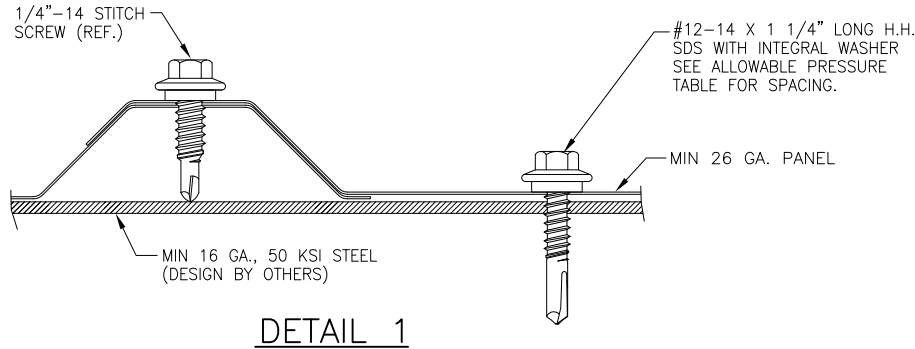

DETAIL 1

GENERAL NOTES:

1. STRUCTURAL ROOF PANEL HAS BEEN DESIGNED IN ACCORDANCE WITH THE FLORIDA BUILDING CODE (FBC).
2. PANELS SHALL BE MIN. 26 GA. (t = 0.0175"). EFFECTIVE COVERING WIDTH OF PANEL = 36".
3. ROOF PANELS SHALL BE INSTALLED OVER STRUCTURE AS SPECIFIED ON THIS DRAWING.
4. REQUIRED DESIGN WIND LOADS SHALL BE DETERMINED FOR EACH PROJECT. THIS PANEL SYSTEM MAY NOT BE INSTALLED WHEN THE REQUIRED DESIGN WIND LOADS ARE GREATER THAN THE ALLOWABLE WIND LOADS SPECIFIED ON THIS DRAWING.
5. ALL FASTENERS MUST BE IN ACCORDANCE WITH THIS DRAWING & THE FLORIDA BUILDING CODE. IF A DIFFERENCE OCCURS BETWEEN THE MINIMUM REQUIREMENTS OF THIS DRAWING & THE CODE, THE CODE SHALL CONTROL.
6. PURLINS/JOISTS/TRUSSES MUST BE DESIGNED TO WITHSTAND WIND LOADS AS REQUIRED FOR EACH APPLICATION AND ARE THE RESPONSIBILITY OF OTHERS.

DRAWN BY: B.S.	CHECKED BY: L.T.
PLOT:	DATE: 8/9/19
NO.	REVISION DESCRIPTION

DRAWING TITLE: **M-LOC ROOF PANEL**

CONSULTANTS: **BALA SOCKALINGAM, PH.D., P.E.**
 1216 N LANSING AVE, SUITE C
 TULSA, OK 74106
 PHONE: 918-492-5992 FAX: 866-366-1543

MANUFACTURER: **CENTRAL STATES MANUFACTURING, INC.**
 302 JANE PLACE
 LOWELL, AR 72745
 800-356-2733

DRAWING NO. 2289-1	REV.
PAGE NO. 1	OF 1