



NEMO|etc.

Certificate of Authorization #32455
353 Christian Street, Unit #13
Oxford, CT 06478
(203) 262-9245

ENGINEER

EVALUATE

TEST

CONSULT

CERTIFY

EVALUATION REPORT

GAF

1 Campus Drive
Parsippany, NJ 07054
(800) 766-3411

Evaluation Report 01506.02.06-R16

FL6267-R16

Date of Issuance: 02/28/2006

Revision 16: 08/14/2019

SCOPE:

This Evaluation Report is issued under **Rule 61G20-3** and the applicable rules and regulations governing the use of construction materials in the State of Florida. The documentation submitted has been reviewed by Robert Nieminen, P.E. for use of the product under the Florida Building Code and Florida Building Code, Residential Volume. The products described herein have been evaluated for compliance with the **6th Edition (2017) Florida Building Code** sections referenced herein.

DESCRIPTION: GAF Roof Ventilation Products

LABELING: Labeling shall be in accordance with the requirements the Accredited Quality Assurance Agency noted herein.

CONTINUED COMPLIANCE: This Evaluation Report is valid until such time as the named product(s) changes, the referenced Quality Assurance documentation changes, or provisions of the Code that relate to the product change. Acceptance of this Evaluation Report by the named client constitutes agreement to notify Robert Nieminen, P.E. of any changes to the product(s), the Quality Assurance or the production facility location(s). NEMO|etc. requires a complete review of this Evaluation Report relative to updated Code requirements with each Code Cycle.

ADVERTISEMENT: The Evaluation Report number preceded by the words "NEMO|etc. Evaluated" may be displayed in advertising literature. If any portion of the Evaluation Report is displayed, then it shall be done in its entirety.

INSPECTION: Upon request, a copy of this entire Evaluation Report shall be provided to the user by the manufacturer or its distributors and shall be available for inspection at the job site at the request of the Building Official.

This Evaluation Report consists of pages 1 through 11.

Prepared by:

Robert J.M. Nieminen, P.E.

Florida Registration No. 59166, Florida DCA ANE1983

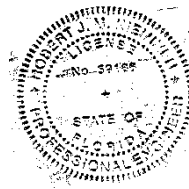

The facsimile seal appearing was authorized by Robert Nieminen, P.E. on 08/14/2019. This does not serve as an electronically signed document.

CERTIFICATION OF INDEPENDENCE:

1. NEMO|etc. does not have, nor does it intend to acquire or will it acquire, a financial interest in any company manufacturing or distributing products it evaluates.
2. NEMO|etc. is not owned, operated or controlled by any company manufacturing or distributing products it evaluates.
3. Robert Nieminen, P.E. does not have nor will acquire, a financial interest in any company manufacturing or distributing products for which the evaluation reports are being issued.
4. Robert Nieminen, P.E. does not have, nor will acquire, a financial interest in any other entity involved in the approval process of the product.
5. This is a building code evaluation. Neither NEMO|etc. nor Robert Nieminen, P.E. are, in any way, the Designer of Record for any project on which this Evaluation Report, or previous versions thereof, is/was used for permitting or design guidance unless retained specifically for that purpose.

ROOFING COMPONENT EVALUATION:
1. SCOPE:

Product Category: Roofing
Sub-Category: Roofing Accessories that are an Integral Part of the Roofing System
Compliance Statement: **GAF Roof Ventilation Products**, as produced by **GAF**, have demonstrated compliance with the following sections of the **6th Edition (2017) Florida Building Code** through testing in accordance with the following Standards. Compliance is subject to the Installation Requirements and Limitations / Conditions of Use set forth herein.

2. STANDARDS:

Section	Property	Standard	Year
1504.3	Wind	ASTM E330	2002
1506.5 / 1517.5.1	Corrosion Resistance (of nails)	TAS 114, Appendix E	1995
1523.6.5.2.13	Wind Driven Rain	TAS 100(A)	1995
1523.6.5.2.13.1	Physical Properties	TAS 110	2000
2615.2	Weatherometer	ASTM G155	2005

3. REFERENCES:

Entity	Examination	Reference	Date
ATI (TST 1558)	Physical Properties	01-49035.01	03/02/2004
ATI (TST 1558)	Wind Driven Rain	01-44964.01	01/15/2004
ATI (TST 1558)	Wind Driven Rain	60172.01-122-18	10/07/2005
ATI (TST 1558)	Physical Properties	59665.02-106-31	09/16/2005
ATI (TST 1558)	Wind Driven Rain	84608.01-106-18	11/12/2008
ATI (TST 1558)	Wind Driven Rain	A5250.01-109-18	02/18/2011
ATI (TST 1558)	Wind Uplift	87074.01-109-44	12/03/2008
ATI (TST 1558)	Wind Uplift	C2396.01-109-44	11/05/2012
ATI (TST 1558)	Wind Uplift	D1957.01-109-44	03/04/2014
ATI (TST 1558)	Wind Uplift	E0818.01-109-44	09/23/2014
ATI (TST 1558)	Physical Properties	D2702.01-106-18	06/30/2014
ATI (TST 1558)	Wind Uplift	E6744.01-109-44	04/30/2015
ATI (TST 1558)	Wind Driven Rain	G2331.01-109-44	01/10/2017
ATI (TST 1558)	Wind Driven Rain	G4123.01-109-18	01/10/2017
ATI (TST 1558)	Wind Uplift	G4123.02-109-44	01/10/2017
ITS (TST 1558)	Physical Properties	H5341.01-106-18 R1	01/22/2018
ITS (TST 1558)	Wind Driven Rain	G2331.03-109-18-R1	06/11/2019
PRI (TST 5878)	Weatherometer	HBP-007-02-01	06/24/2004
PRI (TST 5878)	Physical Properties	HBP-002-02-01	06/06/2001
PRI (TST 5878)	Wind Driven Rain	HBP-01-02-01	11/02/2000
PRI (TST 5878)	Wind Driven Rain	BRY-021-02-01	12/31/2003
PRI (TST 5878)	Physical Properties	BRY-025-02-01	09/17/2004
PRI (TST 5878)	Physical Properties	GAF-138-02-06	02/09/2007
PRI (TST 5878)	Wind Driven Rain	GAF-138-02-04	02/09/2007
PRI (TST 5878)	Wind Driven Rain	GAF-310-02-01	07/07/2011
PRI (TST 5878)	Wind Driven Rain	376T0008	07/25/2019
ETC Labs (TST 2411)	Physical Properties	ETC-01-718-10379.0	01/16/2000
ETC Labs (TST 2411)	Physical Properties	ETC-03-718-14602.0	01/20/2004
ETC Labs (TST 2411)	Physical Properties	ETC-07-718-19959.0	09/27/2007
Miami-Dade (CER 1592)	Various	Various NOAs	Current
Miami-Dade (CER 1592)	Corrosion Resistance (of nails)	Certification L 17-0606.01	06/26/2017
Miami-Dade (CER 1592)	Corrosion Resistance (of nails)	Certification L 17-0821.08	09/25/2017
Miami-Dade (CER 1592)	Corrosion Resistance (of nails)	Certification L 15-0421.09	05/07/2015
UL, LLC. (QUA 9625)	Quality Control	Service Confirmation	12/17/2018

4. PRODUCT DESCRIPTION:

	Name	Description	Published NFVA (in ² /ft)	Manufacturing Location(s)
4.1	Cobra® Exhaust Vent	Low-profile attic ridge vent of mesh-construction for use in shingle roof systems with 12-inch width ridge cap shingles. The product measures 10½-inch wide supplied in 20 and 50 ft long rolls, and is supplied with corrosion resistant 1¾-inch coil nails (nail gun version) or 2½-inch Smart Nails™ (hand nail version).	14.1 (nail gun version) 16.9 (hand nail version)	Acworth, GA
4.2	Cobra® Rigid Vent 3™	Plastic, low-profile attic ridge vent for use in shingle roof systems with 12-inch width ridge caps. The product measures 13-13/16-inch wide supplied in 48-inch long sections, and is supplied with 3-inch corrosion resistant ring shank nails.	18	Cumming, GA New Columbia, PA
4.3	Cobra® Rigid Vent 3™ - 9"	Plastic, low-profile attic ridge vent for use in shingle roof systems with 10-inch width ridge caps. The product measures 11½-inch wide supplied in 48-inch long sections, and is supplied with 3-inch corrosion resistant ring shank nails.	18	Cumming, GA
4.4	Cobra® Snow Country™	Plastic, low-profile attic ridge vent with filter for use in shingle roof systems with 12-inch width ridge cap shingles. The product measures 13-13/16-inch wide supplied in 48-inch long sections.	18	Cumming, GA New Columbia, PA
4.5	Cobra® Snow Country Advanced™	Plastic, low-profile attic ridge vent with filter for use in shingle roof systems with 12-inch width ridge caps. The product measures 13-13/16-inch wide supplied in 48-inch long sections, and is supplied with 3-inch corrosion resistant ring shank nails.	18	Cumming, GA New Columbia, PA
4.6	Cobra® Snow Country Advanced™ - 9"	Plastic, low-profile attic ridge vent with filter for use in shingle roof systems with 10-inch width ridge caps. The product measures 11½-inch wide supplied in 48-inch long sections, and is supplied with 3-inch corrosion resistant ring shank nails.	18	Cumming, GA
4.7	Cobra® RidgeRunner®	Polypropylene plastic, low-profile attic ridge vent for use in shingle roof systems with 12-inch width ridge cap shingles. The product measures 11½-inch wide supplied in 20 ft long rolls, and is supplied with corrosion resistant 1¾-inch coil nails.	12.5	Cumming, GA
4.8	TruSlate® Ridge Vent	Plastic, low-profile attic ridge vent for use in TruSlate® roof systems. The product measures 11.4-inch wide supplied in 48-inch long sections.	20	Cumming, GA
4.9	Cobra® Hip Vent	Plastic, low-profile attic hip vent with filter for use in shingle roof systems with 12-inch width hip shingles. The product, only for use on hips, measures nominal 11.4-inch wide supplied in 48-inch long sections, and is supplied with corrosion resistant 1¾-inch coil nails.	9	Cumming, GA

Name	Description	Published NFVA (in ² /ft)	Manufacturing Location(s)
4.10 Cobra® IntakePro™ Rooftop Intake Vent	Woven plastic material pressed to form the molded shape. A woven fabric material is utilized on the top, bottom and front, below the vent channel of the mold. The vent is configured into a roll-out form.	9	Enka, NC

5. LIMITATIONS:

- 5.1 This is a building code evaluation. Neither NEMO ETC, LLC nor Robert Nieminen, P.E. are, in any way, the Designer of Record for any project on which this Evaluation Report, or previous versions thereof, is/was used for permitting or design guidance unless retained specifically for that purpose.
- 5.2 This Evaluation Report is not for use in FBC HVHZ jurisdictions.
- 5.3 **Minimum Roof Slopes:**

Product	Minimum Slope
Cobra® Exhaust Vent	2:12
Cobra® Rigid Vent 3™	3:12
Cobra® Rigid Vent 3™ - 9"	3:12
Cobra® Snow Country™	3:12
Cobra® Snow Country Advanced™	3:12
Cobra® Snow Country Advanced™ - 9"	3:12
Cobra® RidgeRunner®	3:12
TruSlate® Ridge Vent	5:12
Cobra® Hip Vent	Min. 3:12 to max. 12:12
Cobra® IntakePro™ Rooftop Intake Vent	4:12

- 5.4 Unless otherwise determined through use of performance levels in Section 5.5, the maximum mean roof height for **Cobra® Exhaust Vent, Cobra® Rigid Vent 3, Cobra® Rigid Vent 3 – 9”, Cobra® Snow Country™, Cobra® Snow Country Advanced™, Cobra® Snow Country Advanced™ – 9”, Cobra® RidgeRunner®, TruSlate® Ridge Vent, Cobra® Hip Vent and Cobra® IntakePro™ Rooftop Intake Vent** shall be 33 ft.
- 5.5 **Maximum Allowable Design Pressures:** The following performance levels may be utilized for projects where the maximum mean roof height exceeds 33 ft. The Allowable Design Pressure shall meet or exceed critical design pressure determined by a qualified design professional in accordance with **FBC Chapter 16**. No rational analysis is permitted.

Substrate:	Product	Allowable Design Pressure (psf)
Min. 7/16-inch plywood	Cobra® Exhaust Vent (nail gun version)	-150
Min. 7/16-inch plywood	Cobra® Exhaust Vent (hand nail version)	-180
Min. 7/16-inch plywood	Cobra® Rigid Vent 3™, Rigid Vent 3™ - 9”, Snow Country™, Snow Country Advanced™ and Snow Country Advanced™ - 9”	-215
Min. 7/16-inch OSB or plywood	Cobra® RidgeRunner®	-180
Min. 7/16-inch plywood	TruSlate® Ridge Vent	-190
Min. 7/16-inch plywood	Cobra® Hip Vent	-205
Min. 7/16-inch plywood	Cobra® IntakePro™ Rooftop Intake Vent	-175

- 5.5.1 Allowable Design Pressure is the result of testing for wind load resistance based on allowable wind loads, and reflects the ultimate passing pressure divided by 2 (the 2 to 1 margin of safety per **FBC 1504.9** has already been applied). Refer to **FBC 1609** for determination of design wind loads.
- 5.6 Installation shall result in minimum net free ventilation area requirements set forth in **FBC Sections 1203.2**. When more than one level of roof ridge existing over a single attic space, use ridge vents only at the high ridge.

6. INSTALLATION:

6.1 **GAF Roof Ventilation Products** shall be installed in accordance with **GAF** published installation requirements subject to the Limitations set forth in Section 5 herein and the specifics noted below.

6.2 COBRA® EXHAUST VENT:

- 6.2.1 Chalk a cut-line 1-inch off each side of the ridge and cut a slot along the apex of the roof measuring 2-inch (for truss construction) or 3½-inch (for ridge pole construction). The slot should terminate 6-inches from each end and 12-inches from hip intersections or chimneys. Cut only the sheathing; do not cut trusses. Figure A.
- 6.2.2 Unroll the vent along the entire length of the ridge, covering uncut 6-inch sheathing area on both ends. Shorter lengths can be joined by caulking and butting the ends. Figure B.
- 6.2.3 Apply a bead of polyurethane roof sealant to the underside of the entire perimeter of the vent and nail with min. 2½-inch galvanized roofing nails at each corner and 10-inch o.c.
- 6.2.4 Apply a bead of polyurethane roof sealant in the shape of a “C” to the underside of the entire perimeter of the cap shingles, and install cap shingles directly over the vent using Smart Nails™ or 1¼-inch corrosion resistant coil nails (supplied with the vent). Figure C.

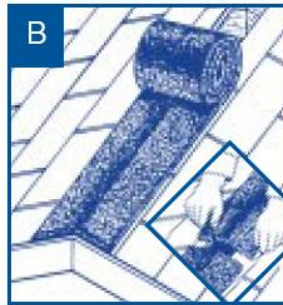
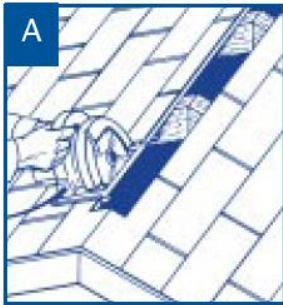

6.2.5 **Cobra® Exhaust Vent (hand nail version)** and **Cobra® Exhaust Vent (nail gun version)** have a ¾-inch or 5/8-inch nominal thickness, respectively, to facilitate ventilation. Care shall be taken not to crush or compact the product during installation. Figure D.

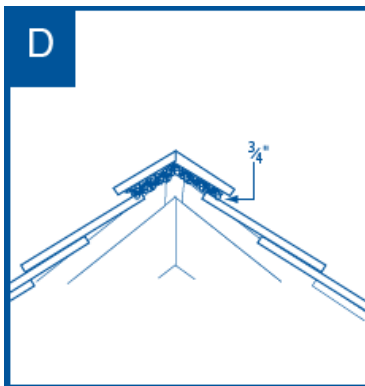

Hand-Nail Version

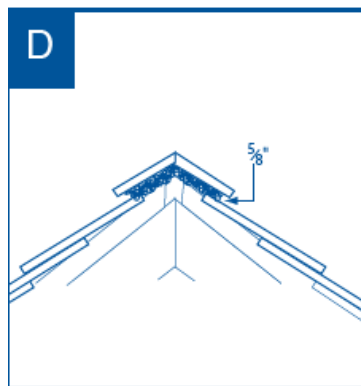

Nail Gun Version

6.3 COBRA® RIGID VENT 3™, RIGID VENT 3™ - 9", SNOW COUNTRY™, SNOW COUNTRY ADVANCED™ AND SNOW COUNTRY ADVANCED™ - 9":

- 6.3.1 Mark-off and cut the slot opening as follows, ensuring that the ends of the opening stop at least 6-inch from any end walls and at least 12-inch from hip and ridge intersections or chimneys.
- **No Ridge Board:** Cut a 7/8-inch opening on each side of the ridge (Figure A).
 - **With Ridge Board:** Cut a 1-5/8-inch opening on each side of the ridge (Figure B).

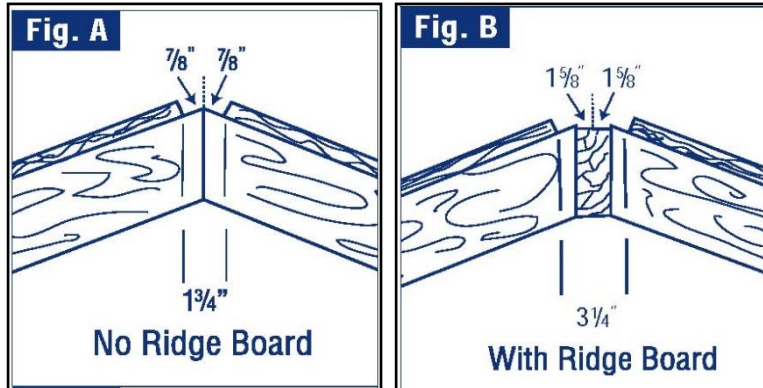

- 6.3.2 **Vent Placement:** Starting at one end of the slot, place, center and conform the Cobra® rigid vent over the slot with the vent firmly against the roof surface, ensuring the vent extends past the slot opening by at least 6-inch.
- 6.3.3 **Fasteners:** For Cobra® Rigid Vent 3™, Cobra® Rigid Vent 3™ - 9", Cobra® Snow Country Advanced™ and Cobra® Snow Country Advanced™ - 9" only, use the 3-inch corrosion resistant ring shank nails (included). For Cobra® Snow Country™, use corrosion resistant nails at least 3-inch or longer. Nails must always penetrate through plywood decks or at least 3/4-inch into wood planks. NOTE: GAF recommends 3-inch corrosion resistant ring shank nails for increased uplift resistance.
- 6.3.4 **Spacing:** Attach the vent section through the pre-molded nailing holes located at 3, 12, 24, 36 and 45-inch from the start of each 48-inch vent piece.
- 6.3.5 **Joints:** Apply the subsequent Cobra® rigid vent sections over the length of the ridge using the overlap/underlap tabs.
- 6.3.6 **Ridge Shingles:** Install ridge shingles in accordance with shingle manufacturer's published installation instructions, using corrosion resistant nails detailed in 6.3.3. A nail line is inscribed on top of the Cobra® rigid vent to serve as a guide.

6.4 COBRA® RIDGERUNNER®

6.4.1 Cut slot per 6.3.1.

6.4.2 Tear a 1-foot section to be used as a template for laying the vent out (Figure E-G) and center the template/ locator over the ridge cap shingles at the beginning of the vent slot. Note the location of the baffle (Figure H). Make sure to do this at both ends of the installation.

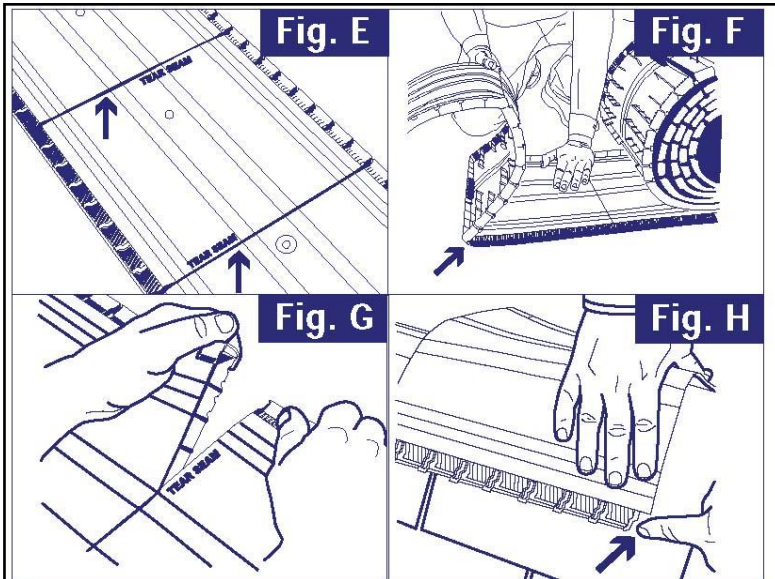

6.4.3 Measure the distance from the edge of the roof slot to the exterior baffle (D). Establish a chalk line along one side of the ridge (Figure I). Unroll the vent and use the included 1-3/4-inch pneumatic corrosion resistant roofing nails to attach the first side of the ridge vent with the exterior of the baffle aligned with the chalk line (Figure J). Proceed with using the 1' interval EasyTear™ system to custom size the vent to the appropriate length. If the EasyTear™ system can not be utilized, use a utility knife to size the vent. Nail gun targets are embossed on the part as a guide for property attaching vent to the roof. The vent should be fastened on 6-inch centers (Figure K).

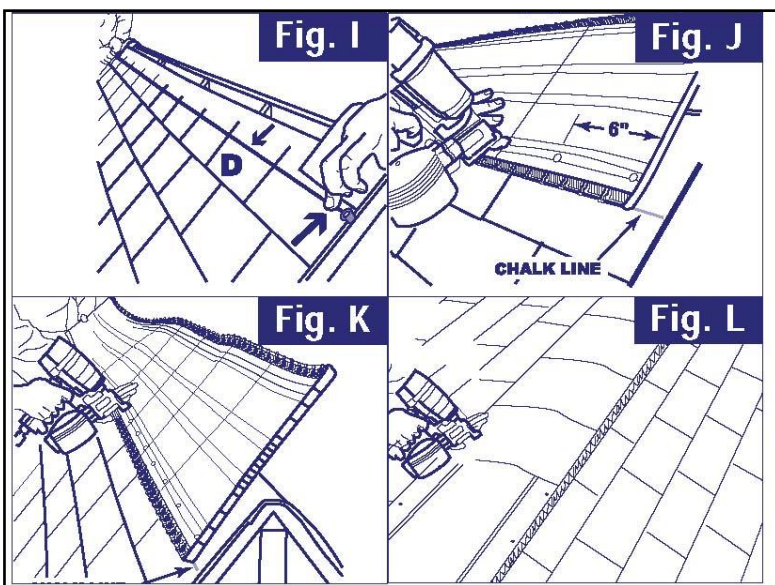

- 6.4.4 For installations over extra-thick shingles, a bead of polyurethane roof sealant may be applied to the underside of the outer baffle of the vent along both sides of the ridge and at exposed edges where the vent meets the shingles to fill any open space between the vent and shingles below.
- 6.4.5 **NOTE:** When fastening the vent and cap shingles, be sure that the included 1 3/4-inch corrosion resistant coil nails completely penetrate plywood or provide at least 3/4-inch penetration into wood planks. In the case they do not, you must use alternate corrosion resistant nails that provide the required penetration. Proceed with attaching the other side of the vent. When beginning to nail down the second side, do NOT begin at the end; begin between the first and second one-foot sections and then return to fasten the first one-foot section. This will allow for proper fit.
- 6.4.6 Install ridge shingles in accordance with shingle manufacturer’s published installation instructions, using the nail-lines on top of the ridge vent for proper lapping.

6.5 TRUSLATE® RIDGE VENT:

- 6.5.1 DO NOT use on hips.
- 6.5.2 Install **TruSlate® Ridge Vent** before installing the field slates.
- 6.5.3 After determining the total length of **TruSlate® Ridge Vent** required (for proper ventilation), determine the necessary slot opening. Mark-off and cut the slot opening, ensuring the ends of the opening stop at least 6-inch from any end walls and at least 12-inch from hip and ridge intersections or chimneys.
 Roofs without a ridge board: Cut a 7/8-inch opening along the ridge on each side (Figure A).
 Roofs with a ridge board: Cut a 1-5/8-inch opening along the ridge on each side (Figure B).

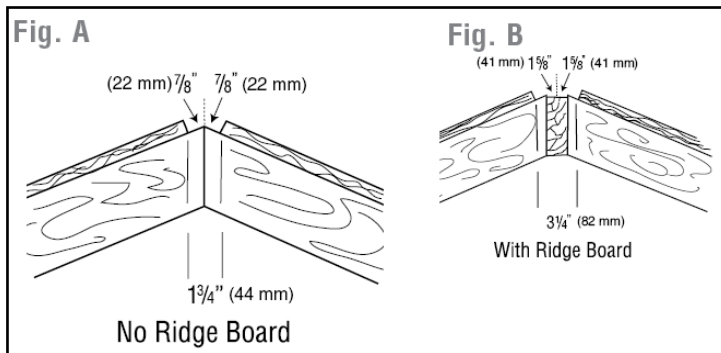

- 6.5.4 Install an 18-inch wide section of ASTM D1970 self-adhering leak barrier (holding Florida Statewide Product Approval or Approved on a Local Basis) from the edge of the ridge slot extending down towards the roof deck on both side of the slot.
- 6.5.5 Place the **TruSlate® Ridge Vent** over the ridge slot, “peaked” and centered over the ridge slot, and attach using minimum 3-inch long corrosion resistant ring-shank nails through the pre-molded nail holes on the vent, located 3-inch from the ends and 9-inch o.c. Fasteners shall penetrate through plywood decks or embed minimum 3/4-inch into wood plank decks.
- 6.5.6 Continue over the length of the ridge, utilizing the male/female connectors to connect units. Ensure the finished ends include the pre-molded end caps. Cover all exposed nail heads on the vent with silicone caulk. Install a bead of exterior grade silicone sealant at the downslope leading edges of the ridge vent, at the junction of the leading edge and the leak-barrier below.
- 6.5.7 Install the top course of TruSlate® field slates, UnderBlock™ UV & Moisture Barrier and TruSlate® trim slates in accordance with GAF published installation instructions. Install **TruSlate® trim slates** with 10-inch exposure using minimum **1-5/8-inch long deck screws** through pre-drilled holes, through the ridge vent to engage the wood deck.

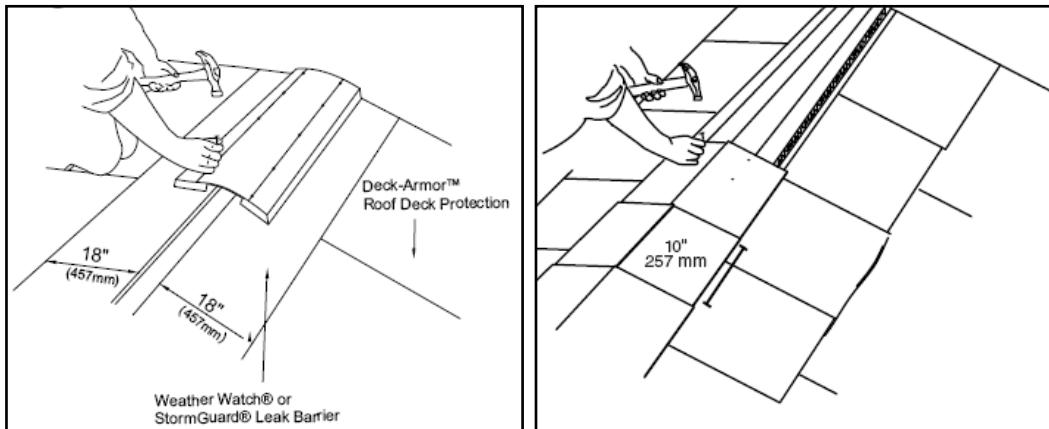

6.6 COBRA® HIP VENT

6.6.1 The roof deck shall consist of minimum of 7/16 inch thick plywood or OSB wood structural panels. Use only on roofs with slopes between 3:12 and 12:12. Install only on hips. Do not install Cobra® Hip Vent on ridges.

6.6.2 **Sequencing:** If ridge ventilation will be installed, always install the ridge vent to the end of the ridge before installing Cobra® Hip Vent.

6.6.3 **Hip Air Slot:** Determine the number of Cobra® Hip Vent sections needed for proper ventilation and the location for cuts in the roof hip. Cobra® Hip Vent is installed over a 2½ inch wide slot opening centered on the hip beginning at 12 inches below the top of the hip and extending 36 inches down the hip for every 4 foot section of Cobra® Hip Vent needed. Leave 12 inches of the hip uncut after each 36 inch opening, and the lowest opening must stop at the mid-point of the hip and more than 24 inches in from the exterior warm wall. Wider openings and slots below the midpoint of the hip will not improve ventilation and must be avoided. Cut away the shingles first with a roofing knife, and then cut the deck with a circular saw. The saw should be adjusted so that the rafters or trusses are not cut. Note: The roof decking must be re-nailed to the rafter at the edge closest to the hip to compensate for the nails removed when the hip slot was cut.

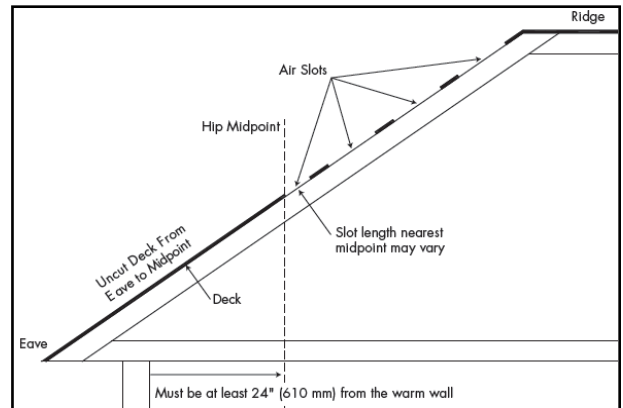

6.6.4 On plywood or OSB roof decks, where a sheathing seam intersects the hip air slot, stop cutting the air slot 2-inches (51 mm) **before** the seam and continue cutting the slot 2-inches (51 mm) **after** the seam, leaving a total of 4-inches (102 mm) of uncut deck at the seam. Then, proceed with cutting down to the previously marked 36-inch (914 mm) point. The air slot may be widened, in this case, to 5/8-inch (16 mm) on each side of the hip rafter to maintain proper NFVA.

6.6.5 **Sealant:** Seal all cut-edges of the asphalt shingles to the roof sheathing along all sides of the hip air slot openings, using a bead of ASTM C920 polyurethane sealant, to prevent water infiltration.



- 6.6.6 **Orientation:** Always install **Cobra® Hip Vent** with the “Towards Peak” arrows on the top surface of the vent pointing up towards the peak of the roof.

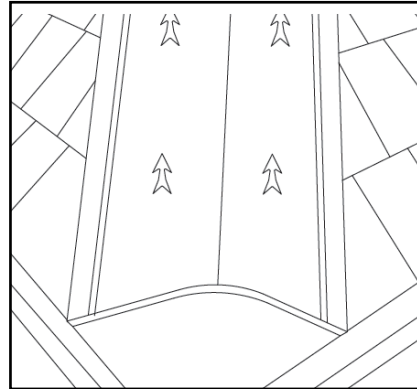

- 6.6.7 **Attachment:** **Cobra® Hip Vent** is fastened to the deck starting at the bottom of the hip and then up along the entire length of the hip (this includes un-cut portions of the hip). Fasten **Cobra® Hip Vent** to the deck with the included 1¾-inch long collated galvanized steel roofing nails, or longer corrosion resistant roofing fasteners, to achieve penetration through plywood or OSB decks or minimum ¾-inch embedment into wood planks. Attach the **Cobra® Hip Vent** section through the pre-marked 6-inch increment nail targets.
- 6.6.8 **Joints & Terminations:** Apply the subsequent **Cobra® Hip Vent** sections over the length of the hip using the overlap/underlap tabs. For roofs with ridge vents, lengths of the hip vent must be butted tightly to sections of ridge vents and install a 3 inch by 12-inch strip of self-adhering leak barrier over all junctions. For roofs without ridge vents, sections of hip vent from adjacent hip runs must be mitered together tightly where they intersect and install a 3 inch by 12-inch strip of self-adhering leak barrier over all junctions. Refer to GAF published installation instruction for details.
- 6.6.9 **Ridge Shingles:** **Cobra® Hip Vent** is then covered with ridge cap shingles and this entire assembly is nailed to the sheathing with the included 1¾-inch long collated galvanized steel roofing nails. Depending on the field and ridge cap shingles used, longer length corrosion resistant fasteners may be necessary. The ridge cap shingles are installed per the shingle manufacturer’s instructions and Florida Product Approval, with a minimum of two nails per shingle and a shingle to shingle nail spacing of 8 inches on center or less. Refer to the shingle manufacturer’s Florida Product Approval for ridge cap shingle fastening and sealing requirements. Do not overdrive the nails or crush/compact the product during installation.

6.7 COBRA® INTAKEPRO™ ROOFTOP INTAKE VENT

- 6.7.1 The roof deck shall consist of minimum of 7/16 inch thick plywood or OSB wood structural panels. Use only on roofs with minimum slope of 4:12. Install only on eave edges of the roof.
- 6.7.2 Determine the length of Cobra® IntakePro™ Rooftop Intake Vent sections needed for proper ventilation and the location for cuts near the roof eave edge. Install a metal drip edge at the eave of the roof. Measure up 6 and 7 inches up from the edge of the metal drip edge and strike chalk lines parallel to the eave of the roof. Cut a 1 inch wide air slot opening along the chalk lines, stopping a minimum of 12" (305 mm) from rake/gable edges, side/end walls, and hip intersections, and stopping a minimum of 24" (610 mm) from the center of valley intersections. The saw should be adjusted so that the rafters or trusses are not cut.
- Note: After cutting the air slot, clear all debris blocking access into the attic space. Be sure to flatten attic insulation near the air slot to allow for proper intake airflow near the air slot. Attic baffles may be used to help prevent insulation from blocking intake airflow into the attic space.
- 6.7.3 Install a minimum 18 inch (457mm) wide FBC Approved peel-and-stick leak barrier down to the roof deck. Align peel-and-stick leak barrier flush to the edge of the roof on top of the drip edge metal. Use a sharp utility knife to cut the leak barrier, re-opening the 1 inch (25 mm) air slot that was previously cut in the deck.

- 6.7.4 Each roll of Cobra® IntakePro™ Rooftop Intake Vent comes with two pieces of end cap fabric. To begin the vent run, place one piece of end cap fabric overhanging halfway over the rake/gable edge and parallel to the eave drip edge. Fasten the fabric to the roof deck using two roofing nails, one high and one low. If necessary, a piece of FBC Approved peel-and-stick leak barrier can be used in lieu of end cap fabric.
- 6.7.5 With the pre-marked dotted nail line and GAF logo facing up toward the sky, position the vent on top of the fabric end cap and flush to the rake/gable edge and eave drip edge. The front venting face of the vent should be flush with the drip edge metal below. Using the included 1-3/4 inch (44 mm) pneumatic coil nails, fasten the vent every 6 inches (152 mm) along the pre-marked nail line and fasten every 12 inches (305 mm), approximately 1-1/2 inches (38 mm) down from the up-slope edge of the vent. Do NOT nail within 1 inch (25 mm) from the side, top, or bottom edges of the vent.
- 6.7.6 Continue installing vent toward the opposite gable/rake edge or termination point. When installing multiple rolls, adjoin the rolls by butting them tightly together. There should be no gap between adjoining sections. The vent must always extend a minimum of 12 inches (305 mm) past any air slots. Miter cut the vent at any valley and hip intersections, ensuring the vent sections are butted tightly together. For terminations at gable and rake edges, cover the end of the vent run using the included fabric end cap in the same manner as the start of the vent run.
- 6.7.7 Install FBC Approved peel-and-stick leak barrier completely covering the top of the vent and extending from the eave edge to a minimum of 24 inches (610 mm) in from the building’s warm wall. The leak barrier should not overhang the vent. Install rake drip edge if necessary.

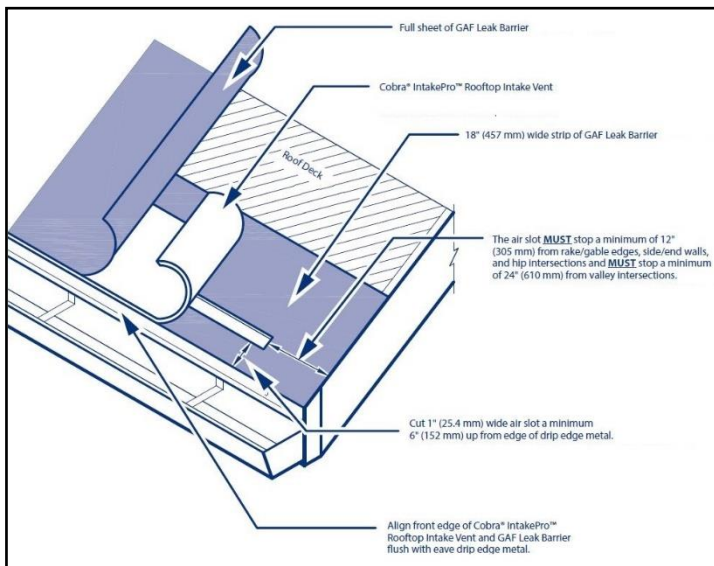

- 6.7.8 Begin installing the shingle starter course. The starter course and first course of field shingles should overhang the front edge of the Cobra® IntakePro™ Rooftop Intake Vent by 1/4 – 3/4 inches (6 – 19 mm) to provide a drip edge. Using the included 1-3/4 inch (44 mm) pneumatic coil nails, fasten the starter strip and field shingles as per manufacturer’s installation instructions. Ensure the field shingles are not fastened into the open air intake slot below.

7. BUILDING PERMIT REQUIREMENTS:

As required by the Building Official or Authority Having Jurisdiction in order to properly evaluate the installation of this product.

8. QUALITY ASSURANCE ENTITY:

UL, LLC. – QUA9625; (847) 664-3281

- END OF EVALUATION REPORT -