

PERFORMANCE TEST REPORT

Rendered to:

GLASSCRAFT DOOR COMPANY

SERIES/MODEL: Buffalo Forge Steel Doors / Round Top Single

PRODUCT TYPE: In-swing Round Top Single Door RH-4

Title	Summary of Results
Uniform Load Deflection Test Pressure	+2594 Pa (+54.18 psf)
Uniform Load Deflection Test Pressure	-2822 Pa (-58.94 psf)
Uniform Load Structural Test Pressure	+3891 Pa (+81.27 psf)
Uniform Load Structural Test Pressure	-4223 Pa (-88.41 psf)

Secure Electronic Seal
for Electronic Submittal

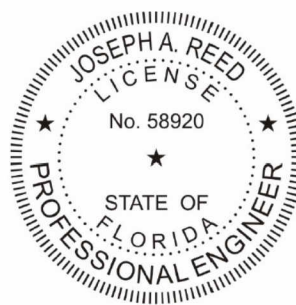

This report contains in its entirety:

Cover Page: 1 page
Report Body: 6 pages
Drawings: 3 pages



Digitally Signed by: Joseph A. Reed

Date: 2010.07.21 10:26:03 -04'00'

Reference should be made to Report No. 72620.01-801-44 for complete test specimen description and data.

PERFORMANCE TEST REPORT

Rendered to:

GLASSCRAFT DOOR COMPANY
2002 Brittmoore Road
Houston, Texas 77043

Report No.: 72620.01-801-44

Revision 1: 07/21/10

Test Date: 04/23/07

Report Date: 06/18/07

**Record Retention End Date: 04/23/11

Project Summary: Architectural Testing, Inc. was contracted by GlassCraft Door Company to perform testing on a Series/Model Buffalo Forge Steel Doors / Round Top Single, in-swing round top single door RH-4. Test specimen description and results are reported herein. The sample was provided by the client. Testing was conducted at the Architectural Testing, Inc. laboratory in Southlake, Texas.

Test Method: The test specimen was evaluated in accordance with:

ASTM E 330-02, Test Method for Structural Performance of Exterior Windows, Curtain Walls and Doors by Uniform Static Air Pressure Difference

Test Specimen Description:

Series/Model: Buffalo Forge Steel Doors / Round Top Single

Product Type: In-swing Round Top Single Door RH-4

Overall Size: 987 mm (38-7/8") wide by 2508 mm (98-3/4") high

Leaf Size: 914 mm (36") wide by 2438 mm (96") high

Door Daylight Opening Size: 572 mm (22-1/2") wide by 2184 mm (86") high

Overall Area: 1.72 m² (18.53 ft²)

Finish: Brown paint

Test Specimen Description: (Continued)

Glazing Details: The insulating glass unit was exterior glazed. It was comprised of two pieces of 1/8" thick tempered pattern glass with a 1/4" air spacer providing 5/8" overall thickness. Butyl tape was located at the exterior and interior with a screw applied steel glazing bead at the interior. Glazing bead screws were located 7" from each corner and 10" on center thereafter.

Weatherstripping:

<u>Description</u>	<u>Quantity</u>	<u>Location</u>
Foam filled vinyl leaf	1 Row	Jambs
Adhesive back foam 1/2" by 1/4"	1 Row	Perimeter of vent frame

Frame Construction: The door frame section was constructed of 4-5/8" thick steel jambs, and included an adjustable extruded aluminum threshold. The aluminum threshold was secured to the jambs with three #8 x 3" screws at each end.

Leaf Construction: The door leaf was constructed from steel with a foam core. A glass frame was secured to the door leaf with three barrel hinges and three sweep latches. Sweep latch keepers were welded to the door leaf. A decorative iron grille was secured at the exterior of the unit.

Hardware:

<u>Description</u>	<u>Quantity</u>	<u>Location</u>
Prodeco hinge	2	10-1/2" and 70-1/2" from the bottom of the leaf
Glass frame hinge	3	12" from each end and the midpoint of each glass frame
Lockset	1	37" from the bottom of the lock stile
Deadbolt	1	43" from the bottom of the lock stile
Sweep latch	3	12" from each end and the midpoint of the glass frame
Sweep latch keeper	3	Door leaf corresponding to each sweep latch

Test Specimen Description: (Continued)

Drainage: Sloped sill

Installation: The jambs were secured to a #2 Yellow Pine test buck with #14 x 3" screws 9" from each corner and 16" on center thereafter.

Test Results: The following results have been recorded:

<u>Test Method</u>	<u>Title of Test</u>	<u>Indicator Readings (inch)</u>		
		<u>#1</u>	<u>#2</u>	<u>#3</u>
ASTM E 330	Uniform Load Deflection			
	(Deflections reported were taken on the active lock stile)			
	(Loads were held for 24 seconds)			
	+2594 Pa (+54.18 psf) (positive)	0.08	0.09	0.08
	-2822 Pa (-58.94 psf) (negative)	0.39	0.15	0.20
ASTM E 330	Uniform Load Structural			
	(Permanent sets reported were taken on the active lock stile)			
	(Loads were held for 10 seconds)			
	+3891 Pa (+81.27 psf) (positive)	0.08	0.09	0.08
	-4223 Pa (-88.41 psf) (negative)	0.04	0.03	0.04

Tape and film were used to seal against air leakage during structural testing. In our opinion, the tape and film did not influence the results of the test.

General Note: Upon completion of testing, the specimens met the requirements of the referenced standards.

**Detailed drawings, data sheets, representative samples of test specimens, a copy of this report, or other pertinent project documentation will be retained by Architectural Testing, Inc. for a period of four years from the original test date. At the end of this retention period, such materials shall be discarded without notice and the service life of this report will expire.

Results obtained are tested values and were secured by using the designated test methods. If test specimen contains glazing, no conclusions of any kind regarding the adequacy or inadequacy of the glass in the test specimen can be made. This report does not constitute certification of this product nor an opinion or endorsement by this laboratory. It is the exclusive property of the client so named herein and relates only to the specimen(s) tested. This report may not be reproduced, except in full, without the written approval of Architectural Testing, Inc.

For ARCHITECTURAL TESTING, INC:



Digitally Signed by: Andy Cost

Andy Cost
Laboratory Manager

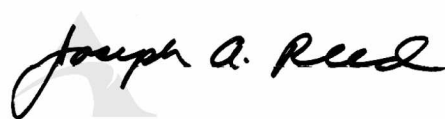

Digitally Signed by: Joseph A. Reed

Joseph A. Reed, P.E.
Director – Engineering / Product Testing

AC:ay/cmd

Attachment(s) (pages): This report is complete only when all attachments listed are included.
Appendix-A: Drawings (3)

Revision Log

<u>Rev. #</u>	<u>Date</u>	<u>Page(s)</u>	<u>Revision(s)</u>
0	06/18/07	N/A	Original report issue
1	07/21/10	1, 5	Replaced Expiration Date wording with Record Retention End Date.

Appendix A

Drawings

Single door
Full arch top



Test sample complies with these details.
Deviations are noted.

Report# 72620.01-801-44
Date 6-13-07 Tech RP

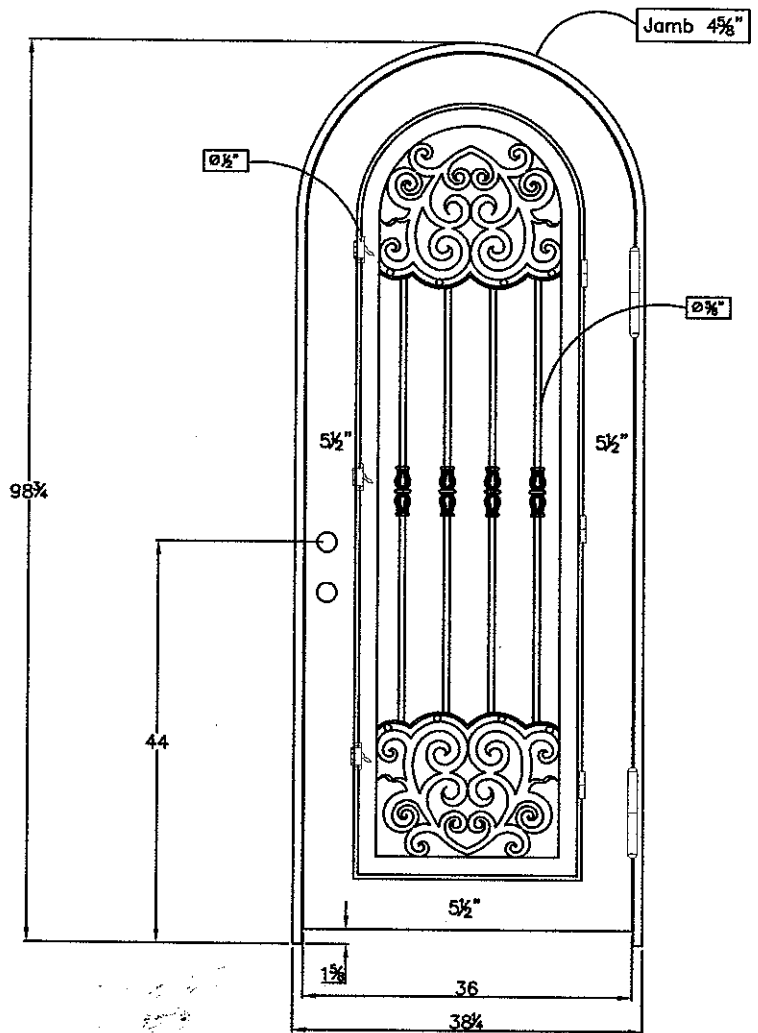
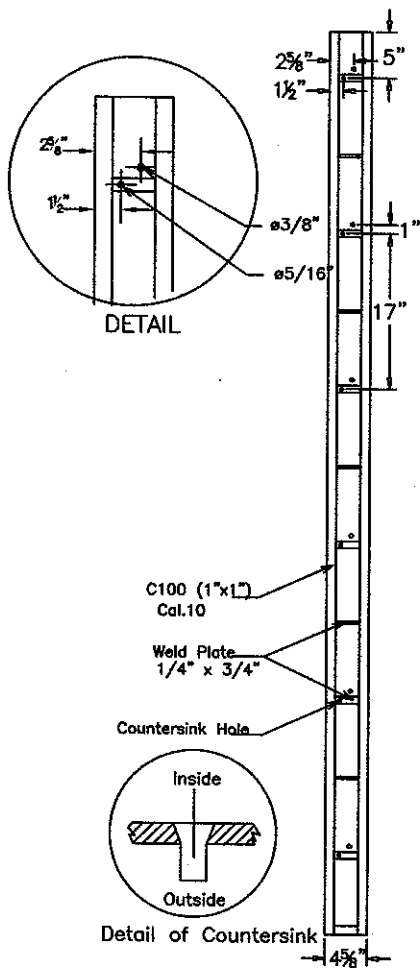

Glass*Craft
Door Company

Single door
Full arch top

list of material

- 1. Door Hardware/ Schlege F-series handle set with Dead Bolt F358ply620
- 2. Z-series sill (Endura
- 3. 98" Compression w/strip bronze

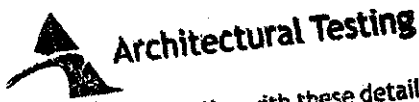

Architectural Testing

Test sample complies with these details.
Deviations are noted.

Report# 72620.01-801-44
Date 6-13-07 Tech AP

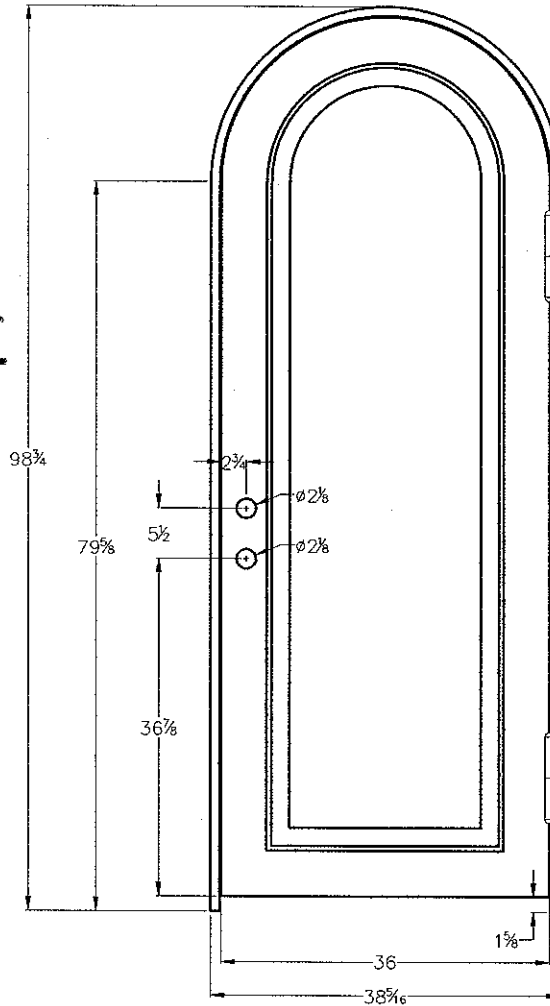

Glass*Craft
Door Company

Door Jam Cross Section

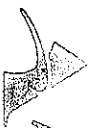

Architectural Testing

Test sample complies with these details.
Deviation: are noted.

Report# 72620.01-801-44

Date 6-13-07 Tech R

3" # 14 F/H Screws

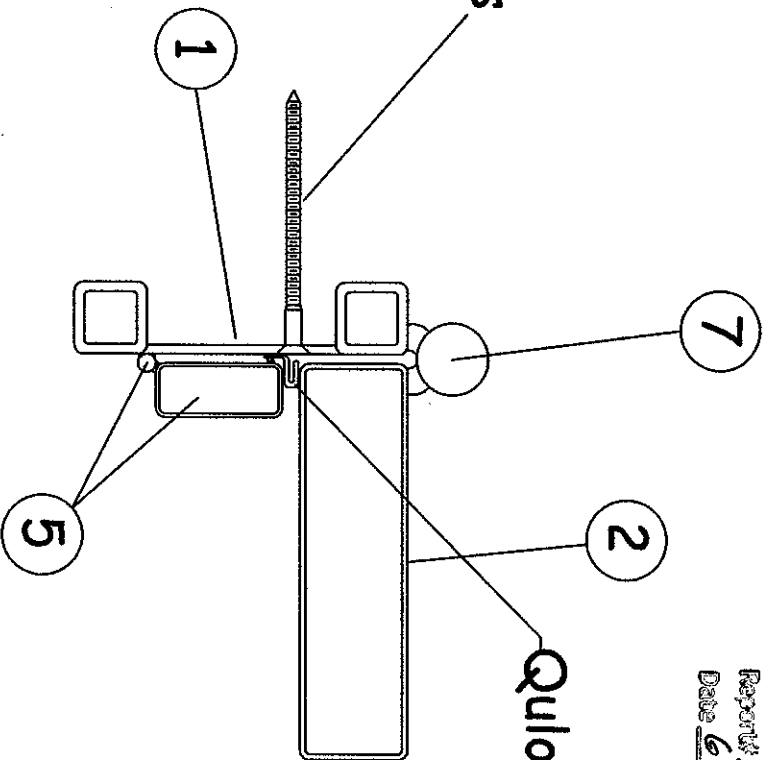

- 1 Jamb
- 2 Stile
- 3 Glass
- 4 Forge
- 5 Door stop
- 6 Astragal
- 7 Prodeco hinge
- 8 Glass frame hinge
- 9 Forge frame
- 10 Fixed glass stop
- 11 Screwed glass stop

Glass*Craft
Door Company